

Appendix O

Comment Letters

This page left blank intentionally.



UNITED STATES ENVIRONMENTAL PROTECTION AGENCY
REGION IX
75 Hawthorne Street
San Francisco, CA 94105

DFC 15 2014

Mr. Brad Hubbard
Bureau of Reclamation
2800 Cottage Way
Sacramento, California 95825

Subject: Draft Environmental Impact Statement for the Long Term Water Transfers Project,
Various Counties, California (CEQ# 20140290)

Dear Mr. Hubbard:

The Environmental Protection Agency has reviewed the Draft Environmental Impact Statement (DEIS) for the above referenced document. Our review is pursuant to the National Environmental Policy Act, Council on Environmental Quality regulations (40 CFR Parts 1500-1508), and our NEPA review authority under Section 309 of the Clean Air Act.

The Long Term Water Transfers Project would implement a 10-year water transfer program to move water from willing sellers upstream of the Sacramento/San Joaquin Delta to willing buyers south of the Delta. Long-term water transfers have the potential to provide improved flexibility in the allocation, management, and use of water resources. When implemented in conjunction with a water management system that includes efficiency improvements, conservation, and environmental protection, they can be an important tool for ensuring that California's scarce water supplies are put to their highest priority use.

While EPA supports the goal of improving water management flexibility, we also recognize that the Delta faces interrelated problems of inadequate water supplies, instream flow deficits, water quality impairments, and degraded aquatic habitats. Many of the groundwater aquifers that previously supported ecosystem processes across the estuary and provided water consumers with a hedge against drought have been overdrawn and depleted to historic levels. The extreme drought of the past 3 years has produced precipitous declines in groundwater elevations statewide, including level decreases of more than 10 feet for some monitored wells in the project area. Land subsidence associated with groundwater overdraft not only impacts infrastructure, water quality, and ecosystems, but also permanently reduces the State's capacity to store water underground. Water transfers would affect each of these conditions; therefore, they must be carefully designed and implemented, based upon the best available data, to ensure that adverse impacts are minimized and the interests of all affected parties and the environment are appropriately considered.

In the DEIS, BOR concludes that, after mitigation, the proposed project would result in less than significant or beneficial environmental impacts for all resources. Based on our review, EPA finds that the DEIS does not contain sufficient information to support this conclusion for many resource areas, particularly groundwater, air quality, fisheries, and wildlife.

The DEIS identifies potentially significant impacts to groundwater levels and land subsidence associated with groundwater substitution water transfers. It states that proposed mitigation would reduce these impacts to less than significant for all groundwater basins in the seller's service area. However, the proposed mitigation is vague and defers the responsibility for developing detailed mitigation plans to the water transfer applicants. This precludes meaningful evaluation of the viability and effectiveness of BOR's proposed approach to mitigation. Furthermore, the modeling performed to assess groundwater-related impacts depends upon a data set spanning 1970 to 2003. The use of this truncated data set means that recent trends and current existing conditions are not appropriately taken into account in the impact analysis. Absent sufficient information regarding both mitigation and existing conditions, the DEIS does not demonstrate that the proposed project would not adversely affect groundwater levels.

3

4

Similarly, while the DEIS concludes that mitigation measures would render potential impacts to air quality to less than significant levels, the two mitigation measures proposed for air impacts essentially amount to a guarantee from BOR that emissions will not be allowed to exceed applicable thresholds. Without information on how these measures would be implemented and enforced on a transfer by transfer basis, it is not clear that the mitigation would successfully prevent exceedence of de minimis values under EPA's General Conformity rule or local air quality thresholds.

5

Finally, the DEIS analysis with regard to fisheries and terrestrial wildlife understates a number of potentially significant adverse impacts upon these resources, thereby rendering unsupportable the conclusion that these impacts will be less than significant. For both fisheries and wildlife impacts, significance thresholds identified in the DEIS are focused around special status species, with insufficient regard for other native communities. It is not clear why the DEIS concludes that most potential impacts to non-special-status species are inherently less than significant. Even where special status species are concerned, the impact analysis frequently depends upon conjecture, without sufficient justification or citation for significance thresholds established and impact assessments made. For example, potential impacts to migratory bird species receive only a summary consideration. Wintering waterfowl in the Sacramento Valley gather as much as 50 percent of their nourishment from rice farms, yet the DEIS concludes that the 16% reduction in flooded rice fields in some regions along the Sacramento River (11% when averaged across the entire sellers' service area) would be a less than significant project effect. The DEIS states that migrating species will simply choose appropriate habitat upon arrival. Neither this assumption, nor the conclusion that follows from it are well founded.

6

7

Similar data gaps and unsupported conclusions are common throughout the DEIS and warrant substantial revision prior to the publication of the Final EIS. The level of detail missing from the DEIS, particularly with regard to the specific provisions of likely transfer actions and the expected requirements of future mitigation, results in an EIS document more appropriate to a programmatic analysis. Without further details regarding these aspects of the proposed project, EPA believes that the FEIS will not be sufficient to support project-level decision-making.

8

Based on EPA's review of the Draft EIS, we have rated the Proposed Action as Environmental Concerns - Insufficient Information (EC-2). This rating reflects the potentially significant adverse environmental impacts that the project, as proposed, may have upon the terrestrial and aquatic environments of the Delta and Sacramento Valley, the lack of consideration of appropriate mitigation for some project impacts, and the need for improved disclosure related to air quality, water quality, groundwater, fisheries, vegetation/wildlife, economics, project alternatives, and mitigation. Please see the enclosed Summary of EPA Rating Definitions for a description of the rating system. Further discussion of our concerns is provided in the enclosed Detailed Comments.

9

EPA appreciates the opportunity to provide comments for this project. When the Final EIS is released for public review, please send one hard copy and one CD to the address above (Mail Code: ENF 4-2). If you have any questions, please contact me at (415) 972-3873 or contact Carter Jessop, the lead reviewer for this project. Carter can be reached at (415) 972-3815 or jessop.carter@epa.gov.

Sincerely,



Kathleen Martyn Goforth, Manager
Environmental Review Section

Enclosures:

Summary of EPA Rating Definitions
Detailed Comments

cc:

Ren Lohofener, Pacific Southwest Region, U.S. Fish and Wildlife Service
Maria Rea, National Oceanic and Atmospheric Administration, National Marine Fisheries Service
Helen Birss, California Department of Fish and Wildlife
Diane Riddle, California State Water Resources Control Board
Karen Huss, Sacramento Metropolitan Air Quality Management District
Frances Mizuno, San Luis & Delta-Mendota Water Authority

SUMMARY OF EPA RATING DEFINITIONS*

This rating system was developed as a means to summarize the U.S. Environmental Protection Agency's (EPA) level of concern with a proposed action. The ratings are a combination of alphabetical categories for evaluation of the environmental impacts of the proposal and numerical categories for evaluation of the adequacy of the Environmental Impact Statement (EIS).

ENVIRONMENTAL IMPACT OF THE ACTION

"LO" (Lack of Objections)

The EPA review has not identified any potential environmental impacts requiring substantive changes to the proposal. The review may have disclosed opportunities for application of mitigation measures that could be accomplished with no more than minor changes to the proposal.

"EC" (Environmental Concerns)

The EPA review has identified environmental impacts that should be avoided in order to fully protect the environment. Corrective measures may require changes to the preferred alternative or application of mitigation measures that can reduce the environmental impact. EPA would like to work with the lead agency to reduce these impacts.

"EO" (Environmental Objections)

The EPA review has identified significant environmental impacts that should be avoided in order to provide adequate protection for the environment. Corrective measures may require substantial changes to the preferred alternative or consideration of some other project alternative (including the no action alternative or a new alternative). EPA intends to work with the lead agency to reduce these impacts.

"EU" (Environmentally Unsatisfactory)

The EPA review has identified adverse environmental impacts that are of sufficient magnitude that they are unsatisfactory from the standpoint of public health or welfare or environmental quality. EPA intends to work with the lead agency to reduce these impacts. If the potentially unsatisfactory impacts are not corrected at the final EIS stage, this proposal will be recommended for referral to the Council on Environmental Quality (CEQ).

ADEQUACY OF THE IMPACT STATEMENT

"Category 1" (Adequate)

EPA believes the draft EIS adequately sets forth the environmental impact(s) of the preferred alternative and those of the alternatives reasonably available to the project or action. No further analysis or data collection is necessary, but the reviewer may suggest the addition of clarifying language or information.

"Category 2" (Insufficient Information)

The draft EIS does not contain sufficient information for EPA to fully assess environmental impacts that should be avoided in order to fully protect the environment, or the EPA reviewer has identified new reasonably available alternatives that are within the spectrum of alternatives analysed in the draft EIS, which could reduce the environmental impacts of the action. The identified additional information, data, analyses, or discussion should be included in the final EIS.

"Category 3" (Inadequate)

EPA does not believe that the draft EIS adequately assesses potentially significant environmental impacts of the action, or the EPA reviewer has identified new, reasonably available alternatives that are outside of the spectrum of alternatives analysed in the draft EIS, which should be analysed in order to reduce the potentially significant environmental impacts. EPA believes that the identified additional information, data, analyses, or discussions are of such a magnitude that they should have full public review at a draft stage. EPA does not believe that the draft EIS is adequate for the purposes of the NEPA and/or Section 309 review, and thus should be formally revised and made available for public comment in a supplemental or revised draft EIS. On the basis of the potential significant impacts involved, this proposal could be a candidate for referral to the CEQ.

*From EPA Manual 1640, Policy and Procedures for the Review of Federal Actions Impacting the Environment.

**EPA Detailed Comments for the Long Term Water Transfers Draft EIS,
Various Counties, California, December 15, 2014**

Air Quality

The proposed project spans five air basins, including numerous attainment, nonattainment, and maintenance areas for a number of National Ambient Air Quality criteria pollutants. Groundwater substitution water transfers would necessitate the use of diesel, natural gas, or electrically powered pumps. According to the DEIS (p. 3.5-38), and as referenced in Appendix F (page F-1), the emissions from these pumps, in particular those powered by diesel fuel, have the potential to exceed the applicable de minimis value for nitrogen oxides (NO_x) established under EPA's General Conformity Rule for the Sacramento Metro non-attainment area. Table F-1 indicates that unmitigated emissions would exceed the de minimis threshold nearly fourfold. In addition, groundwater substitution pumping has the potential to emit criteria pollutants at levels that exceed local air district significance thresholds for volatile organic compounds (VOCs) and NO_x in the Feather River Air Quality Management District and for NO_x for the Sacramento Metropolitan AQMD. 10

In order to address these potential impacts, the DEIS includes mitigation measure AQ-1: "Reduce pumping at diesel or natural gas wells to reduce pumping below significance levels." (p. 3.5-43) It indicates that, following application of this measure, all project emissions are modeled to fall below applicable thresholds. EPA is concerned that measure AQ-1 is very vague. The single paragraph description provided is insufficient to determine whether this measure is capable of achieving the described emissions reductions. It is unclear how BOR would limit diesel or natural gas well pumping and manage individual transfer permits to ensure cumulative compliance. The mechanisms for both emissions accounting and enforcement are similarly unclear. Measure AQ-1 also stipulates that "if an agency is transferring water through cropland idling and groundwater substitution, the reduction in vehicle emissions can partially offset groundwater substitution pumping at a rate of 4.25 acre-feet for water produced by idling to one acre-foot of groundwater pumped." The DEIS provides no citation or explanation for how the 4.25 AF/1 AF ratio was determined. Given the range of potential emissions rates associated with pumps of various ages/tiers and fuel types, plus the differing water needs of various crops, it is unclear how a single ratio of groundwater pumping to cropland idling was derived and deemed universally applicable. 11

EPA's guidance on the General Conformity applicability analysis states, "the Federal agency can take measures to reduce its emissions from the proposed action to in fact below de minimis levels and, thus, the rule would not apply. The changes must be State or Federally enforceable to guarantee that emissions would be below de minimis in the future."¹ While California Environmental Quality Act mitigation measures may be enforceable under state law, the vague language of AQ-1 falls short of guaranteeing the de minimis thresholds will not be exceeded. Without additional information regarding the mechanism and enforcement for mitigation measure AQ-1, the DEIS does not demonstrate that emissions of NO_x in the Sacramento Metro non-attainment area would be limited to below the de minimus threshold. 12

¹ General Conformity Guidance: Questions and Answers (Response to Question 29), July 13, 1994
<http://www.epa.gov/air/genconform/documents/gcgqa_940713.pdf>

Recommendation: Include in the FEIS a detailed description of the processes by which BOR would approve, disapprove or approve with conditions those transfer applications within the Sacramento Metro AQMD such that emissions are maintained below the applicable de minimis and local significance thresholds; similarly for the Feather River AQMD. In order to demonstrate compliance with the General Conformity Rule, the FEIS should clearly show how the proposed mitigation measure would be implemented and enforced. Describe the mechanism for compliance assurance and enforcement, and clearly demonstrate the calculation leading to the 4.25 AF of water produced by idling to one AF of groundwater pumped ratio. Explain why this value is appropriate for all pumping/idling scenarios.

13

The Department of Agriculture's Natural Resource Conservation Service has a program to promote agricultural production and environmental quality as compatible goals, optimize environmental benefits and help farmers and ranchers meet Federal, State, Tribal, and local environmental regulations. Through the Environmental Quality Improvement Program (EQIP), NRCS provides incentive funding to agricultural producers specifically to reduce NOx, VOCs, PM10 and PM2.5. Currently, incentive funds are available throughout California. The funded conservation practices include the replacement of internal combustion engines in irrigation pumps. For more information, go to <http://www.nrcs.usda.gov/wps/portal/nrcs/detail/ca/programs/financial/eqip/?cid=stelprdb1247003>. As the DEIS notes, a California Air Resources Board airborne toxic control measure contains a schedule for the replacement of older and dirtier diesel agricultural engines.

14

Recommendation: Work with irrigation districts to ensure that individual growers participating in the project are aware of NRCS incentive funding to reduce project related air quality impacts. The FEIS should describe this program and the benefits it might offer for reducing potentially significant air quality impacts with regard to General Conformity.

Groundwater Resources

The proposed project has the potential to cause or exacerbate overdraft of groundwater in the sellers' service area if groundwater substitution transfers are not carefully managed, and if mitigation is not aggressively enforced. One of the primary mechanisms whereby water transfers would be made possible under the proposed action is by groundwater substitution. A seller would pump groundwater in lieu of drawing that same volume of surface water from canal or stream flow. That surface water allocation (less carriage water) would then be sold downstream to a willing buyer in the buyer service area. California's limited regulation of groundwater resources has allowed overdraft of groundwater in parts of the State. When groundwater elevations fall below historic lows, aquifers of certain geologies are subject to collapse, resulting in land subsidence. Areas subject to land subsidence have experienced particularly severe financial and ecological repercussions from groundwater overdraft. These impacts stretch far beyond the individuals pumping the groundwater, impacting entire communities and ecosystems. Furthermore, in dry and critical years, a lack of available water leads a greater proportion of water users to pump groundwater to supplement diminished surface water supplies. These circumstances are likely to co-occur with periods of the greatest number of groundwater substitution transfers.

15

The analysis of groundwater impacts assumes that transfers would occur at a rate of 12 out of 33 years, or 36% of the time (p. 2-13), based upon the period of record from 1970 to 2003. This data set is truncated to this period due to the limitations of the CalSim II model used, not because this period was deemed to be the most appropriate to represent future conditions. In fact, according to the DEIS (p. 1-

16

17), north-of-delta to south-of-delta water transfers have taken place in 9 of the past 15 water years -- a rate of 60%. This is nearly double the transfer frequency assumed by the modeling performed.

The proposed project would likely ease and expedite the water transfer process during its 10-year term by removing the need for independent environmental review for transfer approval. The available data suggest that drought frequency will increase and water supply reliability decrease in coming decades as the effects of global climate change take hold of the State (p. 3.6-12). For this reason, it seems reasonable to assume that the frequency of water transfers during the 10-year project term would be at least equivalent to the past 15 years, if not more frequent. This discrepancy could potentially have very substantial influence on the predicted environmental impacts of the project. The conclusions reached in the DEIS regarding impacts upon groundwater elevations, land subsidence, streamflow, water quality, fisheries, wildlife, and economics are predicated on the assumption that natural recharge in non-transfer years will replenish groundwater aquifers. If the modeling performed were based upon the past 15 years of record, the environmental outcomes predicted for each of these resource areas would likely differ from those described in the DEIS.

Recommendations: Complete additional modeling that is more representative of current and future reasonably foreseeable conditions with regard to transfer frequency. These results should be incorporated into each major resource area so potential adverse effects can be properly characterized. If the framework of CalSim II does not accommodate such modeling, we recommend that BOR perform a sensitivity analysis to determine the effect of this discrepancy upon overall conclusions regarding project impacts. In addition, BOR should consider what additional tools might be available for more accurately predicting likely project impacts in the event that transfer frequency occurs closer to the rate observed in the past 15 years.

The DEIS is internally inconsistent in defining and treating baseline/existing groundwater elevations. The characterization of existing groundwater conditions uses data sets that conclude at dates ranging from 1995 to 2013, and none include data from the 2013-2014 critical drought year. Where older, outdated data are used, it is possible that recent trends in groundwater elevations or land subsidence are not represented in the analysis. The current drought is perhaps the most severe the state has ever experienced and would be the relevant baseline for additional impacts from the proposed action, slated to commence in 2015. According to the California Department of Water Resources' November 2014 Drought Update², over 50 percent of monitored wells in the Central and Sacramento Valleys have experienced groundwater level decreases of 2.5 feet or more from spring of 2013 to spring of 2014, with over 20% experiencing decreases of more than 10 feet. For the period from spring 2010 to spring 2014, nearly 30% of monitored wells have experienced declines in excess of 10 feet. While the most severe declines occur in the San Joaquin basin, precipitous declines are none-the-less prevalent across a majority of the sellers' service area. Due to these recent declines, some of the monitored wells in the sellers' service area may have reached historic low levels. Consequently, we are concerned that the extent of, or potential for, land subsidence may be greater than is reflected in the DEIS.

According to the DEIS, five of eleven extensometers placed in the Sacramento Valley Groundwater Basin to monitor land subsidence are showing some amount of subsidence on an annual basis. This suggests that groundwater elevations are likely falling below historic lows in some portions of the Sacramento Basin. Analysis of data from the National Aeronautics and Space Administration (NASA)

² "Public Update for Drought Response: Groundwater Basins with Potential Water Shortages, Gaps in Groundwater Monitoring, Monitoring of Land Subsidence, and Agricultural Land Fallowing," Department of Water Resources, November 2014, http://www.water.ca.gov/waterconditions/docs/DWR_PublicUpdateforDroughtResponse_GroundwaterBasins.pdf

Gravity Recovery and Climate Experiment (GRACE) satellite mission suggests that, in the Central Valley, including the Sacramento basin, substantial loss of groundwater storage has occurred across the period of 2003 to 2010.³

19

Recommendation: Ensure that the most current groundwater elevation and land subsidence data available are used in the characterization of existing conditions and the determination of likely project effects in the FEIS. The FEIS should examine all available data sources regarding groundwater elevations in the seller's service area and include a more thorough consideration of alternate data sources, given data limitations at some monitoring points. We recommend that the FEIS include specific requirements that prohibit the pumping of groundwater below historic lows where the risk of subsidence is present.

20

The DEIS outlines a monitoring and mitigation measure for ensuring that potentially significant impacts to groundwater are offset; however, this measure (GW-1, p. 3.3-88) largely defers the specifics to a required monitoring and mitigation plan to be developed by the water seller for approval by DWR and BOR in an independent post-NEPA permitting process. While a general framework is offered in the DEIS for how mitigation would be constructed, greater detail is needed to sufficiently demonstrate that environmental harm would be offset. The DEIS states that measure GW-1 will mitigate all impacts from groundwater pumping, placing responsibility for mitigating any "significant adverse impacts" of groundwater pumping on the water seller. Beyond the statement that mitigation "could include... curtailment of pumping until water levels raise above historic lows if non-reversible subsidence is detected," no more specific mitigation thresholds or triggers are provided. Inelastic subsidence is a permanent impact. Implementation of mitigation after it has been monitored to occur means that an irreversible and irretrievable commitment of resources will have occurred. The measure also does not include monitoring or mitigation specifically related to minimizing harm to the aquatic environment. It is not clear what actions could or would be taken if groundwater substitution pumping were found to be dewatering a stream or water body (see comments on stream flow and fisheries impacts).

21

Measure GW-1 includes language placing financial responsibility on the transferring party for any repercussions of their pumping on others, including the cost to neighbors if the neighbors' pumping expenses increase, and the costs of infrastructure repair or improvements that may be required due to lower groundwater elevations or non-reversible land subsidence. However, as presented in the DEIS, these provisions are unlikely to be enforceable. The DEIS does not include metrics by which claims would be judged and processed, and responsibility apportioned, nor timeframes in which decisions would be made. Also, the DEIS does not define how "assurances that adequate financial resources are available to cover reasonably anticipated mitigation needs" would be made. Where offsetting a neighbor's pumping expenses or replacing public infrastructure is concerned, the expense to the transferring party could easily exceed the financial benefit of the water transfer by many times over.

22

Recommendation: Provide greater detail about monitoring and mitigation measure GW-1 in the FEIS. The FEIS should include clearly defined mitigation triggers for the foreseeable range of potential environmental impacts associated with groundwater substitution transfers, including potential impacts to groundwater elevations, land subsidence, streamflow, fisheries, vegetation, and wildlife. We recommend that Measure GW-1 be revised to improve its enforceability, including providing metrics by which claims would be judged and responsibility would be apportioned, and timeframes in which decisions and distribution of reimbursements would be

23

³ Famiglietti, J. S., Lo, M., Ho, S. L., et al. "Satellites measure recent rates of groundwater depletion in California's Central Valley," *Geophysical Research Letters*, 5 Feb, 2011.

made. The FEIS should also define what constitutes “adequate financial resources to cover reasonably anticipated mitigation needs” and how their availability would be ensured.

23

Page 3.7-26 of the DEIS states that stream flow reductions as the result of groundwater declines would have a less than significant impact upon fisheries and riparian resources because they “would be observed at monitoring wells in the region and adverse effects on riparian vegetation would be mitigated by implementation of Mitigation Measure GW-1.” The principle mitigation for this impact is the curtailment of pumping until natural recharge corrects the environmental impact. The DEIS overestimates the effectiveness of this measure in avoiding harm to fisheries and riparian resources. Following the curtailment of pumping, a lag time would exist between when the effects of groundwater on streamflows are detected and when the curtailment of pumping would result in the augmentation of stream flows. This lag time could be months to years depending on specific ground and surface water conditions. During this lag time, significant adverse impacts to fisheries could occur.

24

Recommendation: Define, in the FEIS, triggers that would be used to make the decision to continue pumping or to cease pumping. For example, define at what depth below historic lows groundwater pumping would be curtailed, and at what point land subsidence measures are considered to be too great to be elastic and pumping would cease. The FEIS should more accurately characterize the potential for harm to fisheries resources during the lag time between impact observation and mitigation benefit.

25

In September of this year, Governor Jerry Brown signed a suite of three bills -- AB 1739, SB 1168, and SB 1319 -- collectively called the Sustainable Groundwater Management Act, with the intended goal of moving toward the sustainable management of unadjudicated groundwater basins throughout the state. This legislation will be enacted across the term of the Long Term Water Transfers project and has the potential to affect the proposed project.

26

Recommendation: Discuss the Sustainable Groundwater Management Act in the FEIS. The stipulations of this legislation should be identified in the “Regulatory Framework” portion of section 3.3. The FEIS should also discuss the potential effects of this legislation on the actions proposed for this project.

Streamflow Impacts and Water Quality

The proposed project would affect the quantity and timing of streamflows throughout the sellers’ service area and downstream into the Sacramento/San Joaquin Delta. In an aquatic ecosystem that has already been severely degraded by reduced instream flows related to freshwater diversion and groundwater overdraft, any action with the potential to further reduce flows has the potential to significantly impair water quality. The DEIS states that, due to the timing and magnitude of potential impacts to streamflow, the project will not cause violation of any Delta water quality standards (p. 3.2-40).

27

The release of transfer carriage water, defined as the “portion of the transfer that is not diverted in the Delta and becomes Delta outflow” (p. 2-29), has the potential to increase outflows by an average of 1.8% (p. 3.2-47) between October and June. The DEIS states that streamflow losses associated with reservoir refilling, groundwater recharge, and loss of irrigation return water are modeled to reduce Delta outflows by up to 0.3 percent during the spring and winter months (3.2-47). However, as discussed in our comments on groundwater resources, the DEIS analysis assumes that water transfers will take place in approximately 35% of water years, while in the past 15 years, transfers have occurred at almost

28

double this frequency. In the event that transfers occur as often as, or perhaps more often than, observed in recent history, groundwater aquifers may not fully recharge between transfers, resulting in greater impacts to streamflows. Furthermore, it is unclear how the increase in Delta outflow was calculated given that the percent of a given water transfer that will be required for carriage is variable -- assumed for some transfers to be as much as 20% (Sacramento River) and for others to not apply at all (EBMUD diversions) (p. B-18). If the data presented in the DEIS are average values, it is necessary to understand the maximum possible streamflow losses in order to determine the range of possible project impacts.

28

Recommendations: Describe in the FEIS how an increase in transfer frequency might affect expected streamflow and water quality impacts. Clarify how the proportion of a transfer deemed “carriage water” is determined and how these values were used to calculate expected changes in streamflow resulting from project actions.

29

The California State Water Resources Control Board (State Board) has proposed flow criteria for the lower San Joaquin River Basin⁴ and is in the process of preparing a comprehensive update of the Bay Delta Water Quality Control Plan (Bay Delta WQCP) that will include flow criteria for the Delta as a whole.⁵ The State Board’s 2010 Flows Report⁶ underscores the need to increase flows to and through the estuary to support ecosystem processes, safeguard aquatic life, and protect imperiled species. It is not clear whether or how the proposed project would comply with these new requirements at all times.

30

Any water transfer program will have to be designed for operational flexibility so it can comply with existing water quality standards (such as the X2 salinity standard within D-1641⁷), and potentially more stringent standards once the comprehensive Bay Delta WQCP is completed. On the whole, these new requirements are anticipated to necessitate that less water be diverted for human consumption and more be left in the river for aquatic life. While Appendix B provides detailed analysis of the project’s potential effects on the X2 salinity standard, the current text of the DEIS constitutes an insufficient summary of these data (p. 3.2-40). In addition, the modeling performed for assessing impacts to the position of X2 relies upon monthly averages of that position. Monthly averages are not the appropriate “time step” as they can mask violations and standards. Impacts to the position of X2 must be analyzed and evaluated in the units in which the standard is written in order to demonstrate compliance.

31

Recommendations: Recent proposals by the State Board to include specific flow requirements in future Water Quality Control Plans for the Sacramento/San Joaquin River Delta should be discussed in the FEIS. Explain how the proposed project would be designed and operated with the flexibility needed to achieve compliance with current water quality standards and future standards that might be significantly more stringent.

32

⁴ State Water Resources Control Board, December 2012, Public Draft Substitute Environmental Document in Support of Potential Changes to the Water Quality Control Plan for the San Francisco Bay/ Sacramento-San Joaquin Delta Estuary: San Joaquin River Flows and Southern Delta Water Quality. http://www.waterboards.ca.gov/waterrights/water_issues/programs/bay_delta/bay_delta_plan/water_quality_control_planning/2012_sed/

⁵ http://www.waterboards.ca.gov/waterrights/water_issues/programs/bay_delta/bay_delta_plan/water_quality_control_planning/

⁶ http://www.waterboards.ca.gov/waterrights/water_issues/programs/bay_delta/deltaflow/docs/final_rpt080310.pdf

⁷ http://www.waterboards.ca.gov/waterrights/water_issues/programs/bay_delta/decision_1641/index.shtml. X2 refers to the distance from the Golden Gate up the axis of the estuary to the point where daily average salinity is 2 parts per thousand at 1 meter off the bottom. X2 provides a surrogate measure for the low salinity zone favored by an assemblage of native fish where abundance and survival is statistically greater than in other parts of the estuary. <http://online.sfsu.edu/modelds/Files/References/JassbyEtAl1995EcoApps.pdf>

Streamflow modeling data should be analyzed to determine any change in the position of X2 on a daily basis through time in order to demonstrate that water transfers would not cause the X2 standard to be violated. Include in the FEIS a fuller summary of the data contained in Appendix B to properly support the assertion that the proposed project would not violate the existing X2 standard. If any violations of the X2 standard are found in the modeling to occur on a daily basis, the FEIS should identify this significant impact, indicate the frequency of modeled exceedance, and discuss mitigation that would prevent this impact.

33

The DEIS states that changes in streamflow of less than ten cubic feet per second (cfs) are assumed to have no impact upon water quality (p. 3.2-27). This assumption is not supported with appropriate citation or data. The explanation that changes of less than 10 cfs are outside the accuracy of the model employed is insufficient to demonstrate that this threshold is physically or chemically appropriate. Depending on water levels and flow conditions, a loss of 10 cfs could degrade water quality.

34

Recommendation: Explain, in the FEIS, the basis for the assumption that streamflow changes of less than 10 cfs would not affect water quality. If data supporting such an assumption are not available, we recommend that BOR reconsider its use of this assumption for its analysis. If a lower threshold for significance is deemed appropriate, but the available modeling tools lack the resolution to predict all impacts at this threshold, we recommend that the remaining uncertainty be clearly identified in the FEIS and a precautionary approach be taken with regard to permitting water transfer related actions.

35

The DEIS considers potential streamflow impacts to smaller tributaries in Section 3.7. It states that, for rivers and their major tributaries, groundwater and streamflow modeling was compared against historical flow data to assess impacts to surface water flows. For smaller streams and water bodies, where insufficient data were available to allow this approach, the analysis assumed that streamflow response was similar to that of larger adjacent modeled waterways. This approach is significantly flawed. Model resolution is not the appropriate basis for excluding smaller waterways from a more detailed examination. Smaller water bodies will respond differently to changes in groundwater contributions than will larger water bodies and are potentially much more sensitive to small changes in flow magnitude and frequency. Where a loss or reduction in groundwater contributions to a section of a large water way may result in a small reduction in flow, but no loss of ecological function, the same reduction in groundwater contributions to a smaller tributary stream could result in near or complete dewatering and a significant degradation of ecological function.

36

Recommendations: Additional site specific information, including streamflow data and the likely proportion of flow contributed by groundwater, is needed in order to determine the likely effect of groundwater substitution transfers on smaller streams and waterbodies in the sellers' service area. The FEIS should explicitly identify where uncertainty exists due to model limitations, and describe the range of potential impacts contained within that uncertainty. In the absence of the necessary site specific data for a more comprehensive analysis, we recommend that BOR consider taking a precautionous approach to minimize potential ecological risk.

37

The DEIS states that changes in stream flows on the San Joaquin River and in the Sacramento/San Joaquin Delta will be less than significant because total reductions in flow will be only a fraction of a percent. A two percent reduction in flow is identified as the threshold for significance for this impact. A more refined analysis of impacts to species would have to be conducted to determine whether this

38

significance threshold is biologically appropriate. According to the State Board,⁸ U.S. Fish and Wildlife Service,⁹ NMFS,¹⁰ and the California Department of Fish and Wildlife,¹¹ existing conditions in the San Joaquin River basin are not adequate to protect aquatic life. All three fisheries agencies identified salmon and steelhead populations as declining under current flow conditions. The DEIS does not provide sufficient support for the conclusion that this further reduction in flow would not adversely affect these species or other native aquatic species.

38

The DEIS indicates that, under the proposed project, the many waterways in the project area are likely to experience higher flows during some portions of the year but lower flows during wetter periods. There are many benefits to maintaining flood flows in rivers in wet years as they inundate floodplains and initiate ecosystem processes that support aquatic life. Juvenile salmon will rear on seasonally inundated floodplains when available. This has been found to increase growth and survival in the Central Valley, specifically in the Yolo Bypass and the Cosumnes River floodplain.^{12, 13} These benefits to the ecosystem would be lost if peak flows and flood pulses are suppressed, and contribute increased stress on fish populations that are already adversely affected by flow diversions (e.g., loss of spawning gravels, reduced foraging habitat, loss of cold water).

39

Recommendation: More thoroughly analyze the project's potential impacts on native ecosystems, including sensitive and endangered species, from changes in streamflow. Clearly define, in the FEIS, the criteria used for defining harm to species. Where significant impacts are found to occur, the FEIS should discuss potential mitigation measures.

40

The idling of cropland has the potential to result in increased sediment runoff to local waterbodies. The document contends that this impact is expected to be less than significant due to the crust-like surface formed on rice fields after they are drained and the assumption that farmers idling upland crops will employ soil retention measures (p. 3.2-29). The DEIS does not discuss the possible benefits of planting cover crops toward preventing sediment runoff, especially where landowners choose not to employ other erosion control techniques.

41

⁸ State Water Resources Control Board, 3 Aug. 2010, Development of Flow Criteria for the Sacramento-San Joaquin Delta Ecosystem Prepared Pursuant to the Sacramento-San Joaquin Delta Reform Act of 2009, (2010 Flows Report), available at http://www.waterboards.ca.gov/waterrights/water_issues/programs/bay_delta/deltaflow/docs/final_rpt080310.pdf

⁹ "Interior remains concerned that the San Joaquin Basin salmonid populations continue to decline and believes that flow increases are needed to improve salmonid survival and habitat." USFWS May 23, 2011 Phase I Scoping Comments: http://www.waterboards.ca.gov/waterrights/water_issues/programs/bay_delta/bay_delta_plan/water_quality_control_planning/cmmnts052311/amy_aufdemberge.pdf

¹⁰ "Inadequate flow to support fish and their habitats is directly and indirectly linked to many stressors in the San Joaquin river basin and is a primary threat to steelhead and salmon." NMFS Feb. 4, 2011 Phase I Scoping Comments: http://www.waterboards.ca.gov/waterrights/water_issues/programs/bay_delta/bay_delta_plan/water_quality_control_planning/cmmnts020811/010411dpowell.pdf

¹¹ "...current Delta water flows for environmental resources are not adequate to maintain, recover, or restore the functions and processes that support native Delta fish." Executive Summary of California Department of Fish and Game, November 23, 2010, Quantifiable Biological Objectives and Flow Criteria for Aquatic and Terrestrial Species of Concern Dependent on the Delta.

¹² T. R. Sommer, M.L. Nobriga, W.C. Harrell, W. Batham, and W.J. Kimmerer. 2001. Floodplain rearing of juvenile Chinook salmon: evidence of enhanced growth and survival. *Can. J. Fish. Aquat. Sci.* 58: 325-333.

¹³ C. A. Jeffres, J. J. Opperman, and P. Moyle. 2008. Ephemeral floodplain habitats provide best growth conditions for juvenile Chinook salmon in California river. *Environmental Biology of Fishes*. Published online June 6, 2008: www.waterboards.ca.gov/waterrights/water_issues/programs/bay_delta/deltaflow/docs/exhibits/usdoi/spprt_docs/doi_jeffres_2008.pdf

Recommendations: Discuss, in the FEIS, the feasibility and benefit of planting or encouraging the growth of cover vegetation for reducing soil erosion and sediment runoff into waterways.

42

Fisheries

Chapter 3.7 of the DEIS assesses the project's potential impacts upon fisheries. EPA finds that the analysis performed lacks the resolution necessary to identify the full range of potentially significant adverse impacts the project may have upon fisheries, including potential impacts on special status species. The modeling performed for this analysis relied upon the flawed assumptions that a transfer action would have no adverse impact upon fisheries if modeled flow reduction were of less than one cubic foot per second (cfs) or less than a ten percent change in mean flow by water year type (p. 3-7-20). These assumptions inappropriately limit the scope of the impact analysis and undermine the accuracy of the conclusions reached.

43

The DEIS contends that any change in flow of less than ten percent falls within the "noise of model outputs and beyond the ability to measure actual changes" (pg. 3-7-20). It is not logical nor acceptable for purposes of this analysis to conclude that biological impacts are limited to the range of flow changes capable of being represented by the model employed. Research has examined the effects of implementing freshwater flow prescriptions for rivers and estuaries that mimic the pattern of the natural hydrographs in order to protect aquatic species with life histories adapted to such flow patterns.¹⁴ For example, work performed by Richter, et. al.¹⁵ on riverine systems in Florida, Michigan, Maine, and the European Union found that the maximum cumulative depletion of flows allowable to ensure adequate protection of aquatic species ranged from 6 - 20% year-round or in low-flow months and 20-35% in higher flow months. These scientists recommended the equivalent of no less than 90% of natural flow to achieve a high-level of ecological protection, and no less than 80% of natural flow to achieve a moderate level of ecological protection. Central Valley watersheds experience a much higher proportion of flow alteration than these scenarios. For example, during a median year in the San Joaquin River system, only 31% of the natural flow is allowed to remain in the river channel.¹⁶ In a system that is so severely impacted with regard to streamflow, additional reductions in flow of less than ten percent have the potential to cause significant adverse impacts.

44

Similarly, because streams and stream flows vary greatly at the reach scale due to environmental heterogeneity, changes of less than 1 cfs can have significant adverse effects on fishes and amphibians, depending on the specific reach affected and the conditions in that reach at the time of impact. Fishes, especially special status species, rely on high quality reaches as refugia for population persistence. Any degradation of reach quality has the potential to affect population vitality.

45

According to the DEIS, the Central Valley Project Improvement Act of 1992 requires that a transfer "will not adversely affect water supplies for fish and wildlife purposes" (p. 1-11). Based upon the

46

¹⁴ "Major researchers involved in developing ecologically protective flow prescriptions concur that mimicking the unimpaired hydrographic conditions of a river is essential to protecting populations of native aquatic species and promoting natural ecological functions". (Sparks 1995; Walker et al. 1995; Richter et al. 1996; Poff et al. 1997; Tharme and King 1998; Bunn and Arthington 2002; Richter et al. 2003; Tharme 2003; Poff et al. 2006; Poff et al. 2007; Brown and Bauer 2009). SED. Appendix C, p. 116

¹⁵ Richter, B. D., Davis, M., Apse, C., and Konrad, C. P. 2011. A presumptive standard for environmental flow protection. River Research and Applications. DOI: 10.1002/rra.1511. <http://eflow.net.org/downloads/documents/Richter&al2011.pdf>

¹⁶ EPA Comments on the Bay Delta Water Quality Control Plan, Phase I SED. March 28, 2013.

Available at: <http://www2.epa.gov/sites/production/files/documents/sfdelta-epa-comments-swrbc-wqcp-phase1-sed3-28-2013.pdf>

information provided in the DEIS, it is not clear that this provision would be met if the “Full Range of Transfer Measures” project alternative (the preferred alternative) is implemented as currently described.

46

Recommendations: Perform additional modeling and analysis to more accurately assess potential impacts of the project upon fisheries. We recommend discarding the flawed assumptions that underpin the analysis performed for the DEIS. The FEIS should disclose when model resolution is too coarse to capture flow changes with the potential to adversely impact fisheries, and identify measures that would avoid or mitigate adverse impacts to fisheries and the aquatic environment in connection with actions authorized by the proposed project. Explain how and when the need for implementation of such measures would be determined.

47

The bulk of the analysis presented in section 3.7 of the DEIS focuses primarily upon the proposed project’s potential impacts upon a short list of “species of management concern”. It is unclear why the numerous other native fishes potentially affected by the proposed project are not more thoroughly examined. For example, page 3.7-9 provides a list of waterways that do not contain special-status fish species, followed by the statement, “as a result, no further biological analysis was conducted in these waterways”. It is not clear why the DEIS concludes that potential impacts to non-special-status species are inherently less than significant. Numerous native species may inhabit these waterways and may be exposed to adverse conditions as a consequence of this project. Furthermore, the DEIS does not demonstrate that potential impacts to fish assemblages or communities were considered, only impacts upon individual species. While protection of individual special status species is important, the project’s potential impacts upon fisheries at the ecosystem scale may be equally significant and worthy of consideration.

48

Recommendations: Discuss, in the FEIS, the proposed project’s potential impacts upon all native species, rather than focusing solely upon “species of management concern”; this should include analysis of potential impacts upon waterways previously eliminated from analysis for fisheries impacts. We recommend that the FEIS analyze potential impacts to multi-species communities, rather than focus solely on single-species impacts.

49

The DEIS explains that native fishes assemblages in the deep-bodied fishes zone have been replaced largely by non-native assemblages, citing “Moyle (2002)” (page 3.7-6). While this is generally true for the San Joaquin River, it is not an accurate characterization for the Sacramento River system. Many more recent studies of fishes in the Sacramento River system have been produced since 2002 that more accurately characterize the current condition of fisheries in that system.

50

Recommendations: A review of available scientific literature related to the fish assemblages of the Sacramento River should be conducted and the most current reliable data should be employed for defining existing conditions and determining potential project impacts. Based on this review, clarify the potential for the proposed project to adversely affect native fish assemblages in the deep-bodied fishes zone. EPA would be willing to assist BOR in acquiring the relevant literature, if needed.

51

The DEIS understates potentially significant impacts to anadromous fish species by focusing on peak habitation times and locations, without regard for the potentially substantial number of individuals who may occur in waterways outside of peak times. For instance, water transfers, which would occur from July through September, would coincide with the spawning period of winter-run Chinook salmon. The DEIS states that “spawning occurs upstream of the areas potentially affected by the transfers. Due in

52

part to elevated water temperatures in these downstream areas during this period, emigration would be complete before water transfers commence in July.” (pg. 3.7-12) While most winter-run emigration is completed between Sept-June, not all emigration is complete by the end of June, and this is important for such a diminished species because every individual counts. Depending on the water year and river conditions, some fish continue to emigrate beyond June. Therefore, the conclusion that no potential effect to winter-run Chinook salmon emigration would occur is not supported. Similarly, the DEIS indicates that impacts to spring-run Chinook salmon would be less than significant because “the bulk of upstream migration (March-September, peaking May-June) and emigration (November-June) would be complete before water transfers commence in July” (pg. 3.7-13 to 14).

52

While most migration may occur outside the proposed transfer period, the DEIS does not discuss in sufficient detail the potential adverse effects of the proposed project upon those migrating or emigrating fish that would be present in waterways affected by transfer actions. Furthermore, the DEIS contends that, while summer rearing of Central Valley steelhead would overlap with water transfers in the Seller Service Area, “the majority of rearing...would occur in the cooler sections of rivers and creeks above the influence for the water transfers.” (page 3.7-15). This statement requires a citation if it is to serve as the basis for concluding that potential adverse effects on Central Valley steelhead summer rearing is unlikely to occur. Again, while most of the rearing may occur outside the area to be adversely affected by water transfers, the DEIS suggests that this is not the case for all rearing, and this potential adverse effect is not quantified or analyzed in sufficient detail.

53

Recommendation: The FEIS should accurately characterize the potential impact upon winter-run Chinook salmon and Central Valley steelhead. Where adverse impacts are likely to occur, potential mitigation measures should be proposed and analyzed.

54

The discussion of potential impacts to steelhead and hardhead understates potential impacts and ignores the potential consequence for these populations where consecutive dry or critically-dry water years occur. The DEIS states that, although juvenile steelhead and hardhead could be present in some rivers affected by reductions in flows, those reductions occur “only one month and one water year type in one month,” and therefore this impact is not expected to have a substantial effect on these species (page 3.7-28), but the potential adverse effects on these species during this one month period are not clearly characterized. If mortality is possible due to adverse stream conditions, then the brief duration of this impact does not necessary ensure minimal harm. Furthermore, if a dry or critically-dry year follows one of the same, the adverse effects during this one month period could be compounded.

55

Recommendations: Clearly explain the criteria used to conclude that these potential effects on steelhead and hardhead would be less than significant. The cumulative effect analysis should encompass consecutive dry and critically-dry years.

56

Migratory Birds

With the large-scale conversion of Central Valley riparian forests and wetlands to agriculture and suburban development, birds and other wildlife have become increasingly dependent on agricultural lands for food and cover. Ricelands serve as essential breeding and wintering habitat for nearly 187 species of birds, 27 species of mammals, and 15 species of reptiles (of which 30 are considered special-status species)¹⁷. The DEIS focuses almost exclusively on the proposed project’s potential adverse

57

¹⁷ “Wildlife Known to Use California Ricelands,” 2011. Prepared for California Rice Commission <http://calrice.org/pdf/wildlife/Species-Report.pdf>

effects upon special status species while potentially significant adverse effects upon migratory birds are either discounted or ignored altogether. Ricelands provide a high-value food source from the 75,000 tons of grain estimated to remain on the ground each year due to harvesting inefficiencies. As a result, wintering waterfowl are estimated to gather more than 50% of their nourishment from ricelands.

57

The DEIS contends that a reduction in acres of flooded agricultural fields in the Delta resulting from the idling of cropland and the shifting of crops would not affect species migrating to the project area during spring because these species would simply select suitable habitat upon arrival (Section 3.8.2.4.1). But the proposed project could remove up to 51,473 acres (p. 3.8-64) of valuable farmed wetlands from the landscape and the DEIS' apparent conclusion that migratory bird populations can quickly adapt to a radically altered mosaic of fallowed fields and farmed wetlands seems flawed and not supported by scientific documentation. Furthermore, the DEIS appears to incorrectly assume that all other factors will be held equal while cropland idling and water transfers take place. This is not the case. The critically-dry water years in which the maximum amount of water transfers are likely to take place are also the years when Delta farmers are most likely to fallow their lands, either voluntarily or due to water shortage, and these outcomes could greatly compound the adverse effects of the proposed project. For instance, the California Rice Commission reports that while farmers flood between 150,000 and 350,000 acres of ricelands annually in the Southern Sacramento Valley and Delta, farmers planted ~20% fewer acres during 2014 and may flood as little as 50,000 acres of ricelands in the 2014-2015 season due to the ongoing drought and water shortages.¹⁸

58

Recommendations: The FEIS should thoroughly characterize the potential reduction in resting and forage habitat for migratory bird species resulting from cropland idling and crop shifting. The FEIS should consider these potential impacts in the context of current trends regarding habitat availability and anticipated future conditions resulting from climate change and changes in farming practices. The FEIS should discuss means for ensuring that sufficient wetted habitat (natural wetland or flooded field) is available for migrating bird species.

59

Riparian Communities

The project has the potential to have significant adverse effects on riparian systems, but the DEIS discounts these potential effects, in part because "changes in stream flow attributable to the Proposed Action would fall within historical ranges" (page 3.8-52). It should be recognized, however, that water management practices administered by federal and State agencies and local irrigation districts have already caused great stress on riparian systems and their associated fish and wildlife species. Recent consumptive patterns involving surface water diversions and groundwater pumping have, in effect, simulated, for fish and wildlife, severe and prolonged drought conditions whether or not drought conditions are actually present. The shift in hydrological conditions has caused a shift in species composition as native fishes have been overwhelmed and replaced by introduced and invasive aquatic species. Additional stress on these aquatic ecosystems could reinforce these adverse effects and potentially cause permanent, unmitigable impacts. The DEIS identified impacts to Cache, Stony, Coon, and Little Chico creeks that would be significant, with Little Chico Creek going to zero flow under some project scenarios. By their nature, no-flow conditions can lead to long-term and irreplaceable losses of ecosystem function.

60

¹⁸ "Wintering Waterfowl Habitat Concerns Looms Large," California Rice Commission, September 16 2014, <http://calrice.org/blog/?id=1410890340&author=California+Rice+Commission>

Recommendation: Revise the EIS to more accurately characterize potential impacts to riparian communities. Identify robust mitigation measures that would ensure that the proposed project would not diminish instream flows in waterbodies affected by the proposed project.

61

The DEIS identifies GW-1 as a mitigation measure for off-setting the potential adverse effects on stream flows from groundwater substitution, but the proposed measure may not provide full compensation for the potential significant adverse effects on riparian systems. Based on the information provided in the DEIS, it appears that the proposed project does not contain provisions for preventing the complete dewatering of smaller streams near groundwater pumping zones. As mitigation measure GW-1 is designed to be reactionary, dewatered stream conditions might persist for extended periods before natural recharge to aquifers could restore base flows. This could result in serious indirect costs, such as the loss of mature riparian vegetation essential to the structure and function of riparian systems. Even if measures are taken to restore the riparian forest, the genetic losses could be permanent and full restoration may not be possible.

62

Recommendations: Revise measure GW-1 to address potentially irreversible adverse effects to riparian systems and related habitats from the implementation of the proposed project. Include, in the proposed monitoring plan, monitoring of any small tributary streams near the point of groundwater extraction. We recommend that specific mitigation triggers be established identifying the percent reduction in flow outside the natural range that would require a cessation of pumping.

63

Range of Alternatives

In the development of project alternatives, BOR employed a screening criterion that all alternatives must be immediate, flexible, and provide new water to the buyers' service area. The requirement that all project alternatives provide water was used to screen out potential project components involving the conservation or transfer of water within the seller service area (Table 2-1). It is unclear why this screening criterion was deemed necessary and how it relates to the project "need" of immediately implementable and flexible water supplies to alleviate shortages (p. 1-2). The restriction imposed that the alternatives need to "provide water" screens out all alternatives that would promote reducing demand in the buyer area and having water rights holders operate within the limits of their existing legal water rights. Some of the alternatives screened out by this criterion might be found to be environmentally and economically preferable. For example, retirement of drainage impaired areas that leach selenium into the San Joaquin River has been documented to have environmental and economic benefits in a National Economic Development Analysis conducted as part of the San Luis Drainage Feature Re-evaluation FEIS.¹⁹ It is unclear why within basin transfers in the buyers service area, considered in conjunction with demand reducing measures, such as conservation and ~~land fallowing, would not meet the~~ underlying project need to supply water to meet shortages. It is also unclear why groundwater storage ("Build new facilities to recharge and extract groundwater for use in buyer service area") in the buyers service area was deemed as not providing new water supply. If aquifers are recharged in wet years, then that water is pumped and used in dry years, it seems this alternative would offer "new supply" in circumstances similar to those when pumping of groundwater from the seller's service area would enable groundwater substitution transfers.

64

65

¹⁹ San Luis Drainage Feature Re-evaluation Final EIS (2007) available at: http://www.usbr.gov/mp/nepa/nepa_projdetails.cfm?Project_ID=61

Recommendation: Explain how the screening criteria were developed and why the requirement that a project component provide new water was deemed appropriate and necessary. A number of the measures eliminated from further consideration in Table 2-1 warrant further consideration and discussion. The FEIS should explain why measures to limit demand and enable within basin exchange of water in the buyers service area, considered in conjunction with one another, would not meet the screening criteria identified.



SA01

December 1, 2014

Frances Mizuno
Assistance Executive Director
San Luis & Delta-Mendota Water Authority
842 6th Street
Los Banos, CA 93635

Dear Mr. Mizuno:

**LONG-TERM WATER TRANSFERS ENVIRONMENTAL IMPACT
STATEMENT/ENVIRONMENTAL IMPACT REPORT; SCH NO. 2011011010**

The California Department of Fish and Wildlife (CDFW) has reviewed the Bureau of Reclamation and San Luis & Delta-Mendota Water Authority (SLDMWA) Draft Environmental Impact Statement/Environmental Impact Report (EIS/EIR) for the Long-Term Water Transfers Project (Project). Thank you for providing CDFW the opportunity to address its area of statutory responsibility in the EIS/EIR (Cal. Code Regs., tit. 14, §§ 15086 & 15088).

The goal of the Project is to reduce Central Valley Project (CVP) supply shortages caused by dry hydrologic years by transferring water from entities upstream from the Sacramento-San Joaquin Delta to SLDWMA Participating Members and other CVP water contractors south of the Delta. Water would be made available for transfer through groundwater substitution, cropland idling, crop shifting, reservoir release, and conservation. The EIS/EIR evaluates potential impacts of water transfers over a 10-year period, 2015 through 2024.

CEQA Role

CDFW is a Trustee Agency as defined in the Guidelines for the Implementation of the California Environmental Quality Act (Cal. Code Regs., tit. 14, § 15000 et seq.; hereafter CEQA Guidelines) with responsibility for commenting on projects that could affect fish and wildlife resources (CEQA Guidelines, § 15386). CDFW has jurisdiction over the conservation, protection, and management of fish, wildlife, native plants, and the habitat necessary for biologically sustainable populations of those species (i.e., biological resources). As a Trustee Agency, CDFW is responsible for providing, as available, biological expertise to review and comment upon environmental documents and impacts arising from project activities, as those terms are used under CEQA (Fish & G. Code, § 1802).

1

Frances Mizuno
San Luis & Delta-Mendota Water Authority
December 1, 2014
Page 2

CDFW anticipates that it may use the final EIS/EIR and act as a Responsible Agency as part of possible future consideration and issuance of discretionary approvals, described below.

Discretionary Approvals

State Threatened, Endangered, and Candidate Species: CDFW has discretionary authority over activities that could result in the “take” of any species listed as candidate, threatened, or endangered pursuant to the California Endangered Species Act (CESA; Fish & G. Code, § 2050 et seq.). CDFW considers most adverse impacts on CESA-listed species, for the purposes of CEQA, to be significant without mitigation. Take of any CESA-listed species is prohibited except as authorized by state law (Fish & G. Code, §§ 2080 & 2085). Consequently, if Project activities result in take of CESA-listed species, CDFW recommends that the Project proponent seek appropriate authorization prior to Project implementation. This may include an incidental take permit (ITP) or a consistency determination in certain circumstances (Fish & G. Code, §§ 2080.1 & 2081 subd. (b)).

Rivers, Lakes, and Streams: An entity may not: substantially divert or obstruct the natural flow of; substantially change or use any material from the bed, channel, or bank of; or dispose of any debris, waste, or other material into, any river, stream, or lake unless certain conditions are met. For such activities, the entity must provide written notification to CDFW. Based on the written notification and site specific conditions, CDFW will determine if the activity may substantially adversely affect an existing fish or wildlife resource and issue a Lake or Streambed Alteration (LSA) Agreement to the entity that includes reasonable measures necessary to protect the resource (Fish & G. Code, § 1600 et seq.).

Note that CDFW must comply with CEQA prior to issuance of an ITP or LSA Agreement for a project. As such, CDFW may consider the Lead Agency's CEQA documentation for the project. To minimize additional requirements by CDFW and/or under CEQA, the final EIR should fully disclose potential Project impacts on CESA-listed species and any river, lake, or stream, and provide adequate avoidance, minimization, mitigation, monitoring and reporting measures for issuance of an ITP or LSA agreement.

Frances Mizuno
San Luis & Delta-Mendota Water Authority
December 1, 2014
Page 3

COMMENTS AND RECOMMENDATIONS

Project Description

Section ES.2.2, Page ES-6, Table ES-2:

The EIS/EIR states that Merced Irrigation District (ID) is a Potential Seller of 30,000 ac-ft of water. However, Merced ID is seeking a new license from the Federal Energy Regulatory Commission (FERC) for continued operation of the Merced River Hydroelectric Project, and in July 2014, CDFW submitted to FERC recommended mitigation measures for the new license, including significant changes to instream flow releases and reservoir operations. In September 2014, Merced ID responded to CDFW's recommendations in a document filed with FERC as part of the FERC Project No. 2179 administrative record titled, "Merced ID's Reply to Comments, Recommendations, Preliminary Terms and Conditions, and Preliminary Fishway Prescriptions." On pages 106-107 of this document, Merced ID predicted that compliance with CDFW flow recommendations "increases the average annual water supply shortage by more than 100,000 ac-ft and creates shortages in most year types. [CDFW's] recommendation reduces average annual carryover capacity storage by...73,000 ac-ft compared to the Merced ID's Proposed Project." Analogous recommendations by the U.S. Fish and Wildlife Service (USFWS) and other agencies to modify flow releases and reservoir operations received similar responses from Merced ID, all indicating significant water supply shortages and reduced carryover volumes if the recommended mitigation measures were implemented. There appears to be a substantive disconnect between these kinds of water supply evaluations in the FERC administrative record and the Project EIS/EIR which lists Merced ID as a willing seller of up to 30,000 ac-ft annually.

2

CDFW recommends that the EIS/EIR scope reference the ongoing FERC relicensing and incorporate the water supply and carryover volume analyses submitted by Merced ID to FERC. A Draft Environmental Impact Statement prepared by FERC for Merced ID's Hydroelectric Project is estimated to be issued in March 2015 and finalized in August 2015.

Section ES.3.2, Page ES-9, Table ES-3:

This section states, "[i]n the No Action/No Project Alternative the Buyer Service Area would experience shortages and could increase groundwater pumping, idle cropland, or retire land to address those shortages." However, this may not be an accurate description of this alternative because the Buyer Service Area currently utilizes short-term transfers to address their water needs. Further, due to existing transfers, the Central Valley Project Improvement Act Refuge Water Supply Program, which maintains and improves wetland habitat areas, is currently experiencing water transfer

3

Frances Mizuno
 San Luis & Delta-Mendota Water Authority
 December 1, 2014
 Page 4

capacity issues concerning its already limited water supply, even without implementation of the Project. For example, this year at the Volta Wildlife Area, the last known population of giant garter snake (*Thamnophis giga*, GGS) in the western San Joaquin Valley was threatened with incidental take pursuant to CESA due to surface water supply limitations and likely operational constraints of conveyance systems needed to provide water needed for habitat. Cumulative impacts from short-term transfers and long term transfers proposed by the Project may have a significant impact on fish and wildlife that utilize refuges by resulting in a substantial adverse impact on sensitive species or interfering substantially with the movement of native migratory species.

3

CDFW recommends that that EIS/EIR describe the relationship between the existing short-term water transfers and long term transfers proposed by the Project, including an analysis of cumulative impacts from these activities, and any potentially significant impacts on fish and wildlife resources. Mitigation should be proposed if warranted.

Environmental Setting

Section 2.3.2.4, Page 2-30:

This section references, but does not clearly define, “protected aquatic habitats.” Project activities could result in substantial adverse impacts on aquatic habitats that are not clearly designated as “protected aquatic habitats.”

4

CDFW recommends that the EIS/EIR expand the definition of “protected aquatic habitats” to include public lands under conservation easement, State wildlife areas and ecological reserves, federal refuges, and private managed wetlands because management efforts to protect GGS occur on these lands. Also identify how and to whom the seller will demonstrate that any impacts to special-status species have been addressed, including through coordination with CDFW and USFWS.

Section 2.3.2.4, Page 2-30:

This section states that the determination of Priority GGS habitat will be made through coordination with GGS experts, Geographic Information System (GIS) analysis of habitat proximity to historic tule (*Schoenoplectus* sp.) marsh, and GIS analysis of suitable habitat. However, this may not be sufficient to ensure appropriate identification of GGS habitat or areas that should be “prioritized” for species conservation. This could result in a substantial adverse impact on the species should appropriate habitat be overlooked.

5

CDFW recommends that the EIS/EIR state that consultation with CDFW and USFWS is required to ensure appropriate identification of GGS habitat and to evaluate which fields

Frances Mizuno
 San Luis & Delta-Mendota Water Authority
 December 1, 2014
 Page 5

to fallow, through review of the CDFW's California Natural Diversity Database (CNDDDB), review of rice fields which will be in production, and fallowing away from canals in a patchwork fashion to maximize habitat connectivity.

5

Section 2.4, Page 2-41, Table 2.9:

This table states that use of transfer water in the Buyer Service Area may result in increased irrigation on drainage impaired lands in the Buyer Service Area which could affect water quality, but that this impact is less than significant. However, significant environmental damage to fish and wildlife resources has occurred in the past from discharge of drainage from impaired lands. Many federal, state, and private managed wetland areas in the Central Valley are located at the lower end of watershed drainage areas and receive irrigation return flows as part of their water supply.

6

CDFW recommends the EIS/EIR analyze potentially significant impacts from increased irrigation on drainage impaired lands on Central Valley managed wetland public trust fish and wildlife resources.

Table 2.9 of this section states that cropland idling/shifting could alter the amount of suitable habitat for natural communities and special-status wildlife species associated with seasonally flooded agriculture and associated irrigation waterways. This impact is identified as less than significant. However, cropland idling/shifting could have a significant impact on habitat availability for shorebirds, resident and migratory waterfowl, and special-status species in the Central Valley, especially if shifting reduces the amount of seasonally flooded post-harvest rice and corn. Seasonal flooding of post-harvest rice and corn provides a substantial percentage of habitat and food supplies for migratory waterfowl. The 2006 Central Valley Joint Venture Implementation Plan estimates that 170,000 acres of post-harvest rice is needed for wintering waterfowl and wintering shorebirds in order to meet bird conservation goals.

7

CDFW recommends that the EIS/EIR address potentially significant impacts of cropland/idling shifting on fish and wildlife resources. Impacts could be mitigated if buyers of transfer water created equivalent habitat or habitat values to those that would be lost.

Section 3.1.2.1, Page 3.1-14:

SACFEM2013 was used to model streamflow depletion from groundwater substitutions. Outputs from this model were used in a post-processing tool to simulate transfers and delta exports in order to analyze potential impacts to surface water supplies. However, it is unclear why monitoring data collected from 2007-2010 transfers were not used to support the models.

8

Frances Mizuno
 San Luis & Delta-Mendota Water Authority
 December 1, 2014
 Page 6

CDFW recommends that the EIS/EIR explain what type of data (i.e., surface flow depletions from groundwater substitution pumping) were collected by the Sellers from all years that transfers took place, and specifically from the recent four consecutive years of transfers (2007-2010). The document should discuss why these data were not used in the analysis of impacts to streamflow from groundwater substitution pumping.

8

Section 3.3.4.1, Page 3.3-88 to 3.3-91:

Groundwater substitution transfers can create time delays between additional groundwater pumping and potential impacts on stream systems. These delays may have significant impacts on timing and availability of surface flow to resident and anadromous fish species, special status species, and other fish and wildlife resources. The Department of Water Resources has been studying stream flow depletions as they relate to Sacramento Valley groundwater substitution transfers for several years.

9

CDFW recommends that the EIS/EIR include the results of the Department of Water Resources studies and analyze potential impacts on fish and wildlife resources resulting from time delays.

Section 3.7.1.3.2, Page 3.7-9:

This section lists the names of five creeks where no sampling information is available to indicate the presence of special-status fish species. Presence was assumed and further biological analyses were conducted in these waterways. However, this section inconsistently lists four of the five same creeks (along with 15 others) and states that a review of field sampling data and reports indicates that there is no evidence of the presence of special-status fish species in these waterways and, as a result, no further biological analysis was conducted.

10

CDFW recommends that the EIS/EIR clarify whether these five creeks may support special-status fish species.

Section 3.8, Page 3.8-20, Table 3.8-1:

The EIS/EIR includes western pond turtle (*Actinemys marmorata*, WPT) as a "listed" species. However, WPT is a Species of Special Concern (SSC), and is not CESA-listed or listed under the federal Endangered Species Act. Pacific pond turtle is used throughout the EIS/EIR in reference to WPT.

11

CDFW recommends that WPT be described as an SSC and moved to the following rows that describe SSC in Table 3.8-1. The species should be consistently referred to as "western pond turtle (WPT)" throughout the EIS/EIR.

Frances Mizuno
 San Luis & Delta-Mendota Water Authority
 December 1, 2014
 Page 7

Impacts

Section 1.3.2.4, Page 1-14:

This section addresses impacts on fish and wildlife resources, and states that Water Code sections 1725 and 1736 require the State Water Resources Control Board to make a finding that proposed transfers would not result in unreasonable impacts on fish and wildlife or other instream beneficial uses prior to approving a change in post-1914 water rights.

CDFW recommends adding the following information to Section 1.3.2.4 for regulatory consistency and clarity: California Code of Regulations Title 23 section 794 requires the petitioner to 1) provide information identifying any effects of the proposed changes on fish, wildlife, and other instream beneficial uses, and 2) request consultation with CDFW and the Regional Water Quality Control Board regarding potential effects of the proposed changes on water quality, fish, wildlife and other in stream beneficial uses. The petition for change will not be accepted by the State Water Resources Control Board unless it contains the required information and consultation request. Early communication with CDFW would streamline the consultation process through "up front" coordination regarding assessment of the potential impact to fish and wildlife resources. The State Water Resources Control Board will use this information in making their finding that proposed transfers do not result in unreasonable impacts on fish and wildlife or other instream beneficial uses

12

Section 2.3.2.1, Page 2-10:

CDFW recommends that the EIS/EIR clarify if water transferred via forbearance agreements were analyzed as part of the Project. If not, impacts from potential increases in groundwater pumping by seller agencies forbearing CVP water should be analyzed as a reasonably foreseeable future action/probable future project in the cumulative impacts analysis of each section.

13

Section 2.3.2.4, Page 2-29 to 2-30:

It is common for CDFW to review proposed water transfer CEQA documents, typically Negative Declarations, which do not address Environmental Commitments. Data may not be available to support the transfer request relative to potential impacts to fish and wildlife.

14

CDFW recommends that all proposed water transfers address Environmental Commitments and potential impacts on fish and wildlife. Include analysis of any previous transfers, monitoring, and mitigation efforts, and identification of how much water was actually transferred in previous years. Annual review of mapped acreage,

Frances Mizuno
San Luis & Delta-Mendota Water Authority
December 1, 2014
Page 8

diverted acre feet of water and monitoring and reporting results would provide a basis to develop baseline information on potential impacts of future proposed transfers.

This section states that Bureau of Reclamation would provide maps to USFWS in June of each year showing the parcels of riceland that are idled for the purpose of transferring water for that year.

14

CDFW recommends that the EIS/EIR state that these maps would also be provided to CDFW and the GGS interagency management team in order to provide coordination for conservation and management of Central Valley GGS populations.

Section 3.7.1.3.3, Page 3.7-15:

Summer rearing of Central Valley steelhead would overlap with water transfers occurring in the Seller Service Area (July-September), both in the Sacramento and San Joaquin River and their tributaries. Thus, water transfers have the potential to impact steelhead. The majority of rearing, however, would occur in the cooler sections of rivers and creeks above the influence for the transfers. Earlier in the Draft EIS/EIR, it is stated that water made available from groundwater substitution transfers may start as early as April (Page 2-10).

15

CDFW recommends that the EIS/EIR clarify when groundwater substitution transfers could begin and, if necessary, analyze impacts on Central Valley steelhead that may be impacted by groundwater transfers occurring in April, May and June.

Section 3.7.2.1.3, Page 3.7-20:

For smaller tributaries, the impact analysis compared modeled groundwater depletion flow rates to available data on mean flow rates for the historical period of record and identified changes to these monthly average flow rates that would result from water transfer actions. Significant impacts on fisheries resources due to stream flow depletions are more likely to occur during low-flow periods of any given month.

16

CDFW recommends that the EIS/EIR analyze the impacts from groundwater pumping on the low-flow period of each month, rather than the average stream flow for the entire month, in order to determine the significance of impacts on fisheries resources and special-status fish species during this sensitive period.

This section states that development of the impact analysis involved literature review, review of known occurrences of special-status species based on the CNDDDB, USFWS regional species lists, information from National Oceanic and Atmospheric Association fisheries website, and results of hydrologic modeling.

17

Frances Mizuno
San Luis & Delta-Mendota Water Authority
December 1, 2014
Page 9

CDFW recommends that the EIS/EIR also include a discussion of how monitoring plans and monitoring data from previous years were used to show that transfers did not adversely affect fisheries resources.

17

This section states that historical stream flow information for small streams were gathered where available and used as the measure of baseline flow. For locations for which historical flow data were limited or unavailable, a qualitative discussion of potential impacts is included for these locations.

18

CDFW recommends that the EIS/EIR include a table or an appendix to show which streams used available historic flow data, what this data included, and which streams lacked historic data and were subject to a qualitative analysis. This information will guide where additional stream flow efforts are needed relative to fisheries resource needs.

Section 3.7.2.4.1, Page 3.7-26 - 3.7-27:

Eastside/Cross Canal and Salt Creek have the potential for impacts on special-status fish species due to flow reductions, although no data were available to determine the proportional reduction in base flows (i.e., if a greater than 10 percent reduction would occur). This section states that these waterways are 1) "generally" not immediately adjacent to groundwater substitution transfers; 2) other "nearby" small waterways are not experiencing flow decreases that are causing significant impacts to aquatic resources; and 3) flow reductions would be observed at monitoring wells in the region and any adverse effects would be mitigated by implementation of Mitigation Measure GW-1. The mitigation plan would include curtailment of the pumping until natural recharge corrects the environmental impact. Therefore, the impacts on fisheries resources would be less than significant. However, it is unclear what the trigger for pumping curtailment would be and how cessation of pumping to allow natural recharge to "correct the environmental impact" mitigates this impact to a less than significant level if the impact has already occurred.

19

CDFW recommends that the EIS/EIR define "generally not immediately adjacent," explain how the determination was made that other "nearby" small waterways are not experiencing flow decreases that are impacting aquatic resources, and how these surrogate waterways relate to the potentially impacted streams. Additionally, the EIS/EIR should identify 1) how the placement and use of monitoring wells would be able to observe instream flow reductions, 2) how the trigger for curtailment of pumping that causes an adverse impact was derived, and 3) if the time from observation of streamflow reductions that result in adverse impacts to the cessation of groundwater pumping would be responsive enough to mitigate for impacts (Barlow and Leake 2012). This recommendation also applies to Section 3.7.6.1.1, which analyzes the cumulative impacts on fisheries resources and special-status fish species in Cache Creek, Stony

Frances Mizuno
San Luis & Delta-Mendota Water Authority
December 1, 2014
Page 10

Creek, Coon Creek, Little Chico Creek, Bear River, Eastside/Cross Canal and Salt Creek and Section 3.8.2.4.1, which analyzes the effects of substantially reduced stream flows as a result of groundwater substitution pumping on the riparian natural communities in Cache and Stony Creeks. 19

This section lists 21 waterways where the Project would have a less than significant impact on fisheries resources and special-status fish species. The basis for this determination is that modeled flow changes would be small and no substantial effect on water quality would result from implementing the Proposed Action.

CDFW recommends that "water quality" in the previous sentence be replaced with "fisheries resources" and tables similar to Tables 3.8-5 and 3.8-7, which show the average monthly flow by water year type in Cache Creek and Stony Creek, respectively, under the No Action/No Project alternative (using historical data) and the Project (using the groundwater model's prediction of reduced flows from the Proposed Action), be included for all streams that have the potential to be impacted by the Proposed Action. As stated above, CDFW recommends that the analysis of potential impacts from groundwater pumping use data from the low-flow period of each month, rather than the average stream flow for the entire month, to determine the significance of impacts to fisheries resources and special-status fish species during this sensitive period. 20

Section 3.7.2.4.1, Pages 3.7-28 to 3.7-29:

This section states that due to incomplete baseline flow data, modeling results were compared to only three years (2003-2005) of existing stream gage data for Coon Creek, indicating that there would be one water year in one month in which flows could potentially be reduced by more than 10 percent. This modeled reduction to baseline flows is stated to be a "worst case scenario" because flows used in this calculation are at the low end (20 cfs) of existing flow data range (20-40 cfs). Modeling shows that flows in all other months and water year types would be reduced by less than 10 percent of baseline flows and, therefore, impacts on fisheries resources would be less than significant. Omitted from this analysis is that the Water Year types for 2003, 2004 and 2005 were categorized as above normal, below normal, and above normal, respectively. It is unclear how this analysis of reductions is considered a "worst case scenario" if the low end of the baseline flow data range (20 cfs) was observed in either an above normal or below normal water year. Regardless of available gage data, it is rational to expect lower flows in Coon Creek in a dry or critically dry year, which would result in the Project reducing baseline flows by more than 10 percent. 21

CDFW recommends that the EIS/EIR explain how stream gage data taken from only above normal and below normal water years, which is then used as baseline flows for comparing to model results, captures the full extent of the potential impacts to fisheries resources in Coon Creek that may occur in dry or critically dry years. This explanation

Frances Mizuno
 San Luis & Delta-Mendota Water Authority
 December 1, 2014
 Page 11

should also be included for impacts on natural communities and wildlife species habitat (Page 3.8-59). 21

This section states that pursuant to model results, Little Chico Creek flows would be reduced by more than 10 percent in multiple water year types from July to October. Although this reduction could be as much as 100 percent of instream flows, the Project would not have a substantial impact on fisheries resources. The reason being that it's not uncommon for natural flows to be very low during these months (0.5 cfs and below), which causes an increase in temperature and reduced dissolved oxygen levels intolerable for over-summering adult spring-run Chinook salmon, so the fish would not be present anyway. Also, depletions from groundwater pumping would cause levels to be within the flow range normally experienced by any juvenile steelhead and hardhead species have experienced low-to-no flows in the past, project impacts that reduce flows to this level would not harm them. 22

CDFW recommends that the EIS/EIR analysis focus on the impacts that low flow periods in Little Chico Creek have on special-status fish species and fisheries resources in general, what an increase to the frequency of these low flow events caused by the Project means to these species, and how do the periods were the Project completely dewateres the creek (i.e., reductions of "up to 100 percent of instream flows") affect stream connectivity, species movement, and the overall health of the species.

Section 3.8.2, Page 3.8-35:

This section states that the distribution of water year types within the action period is unknown. Additionally, the exact locations of cropland idling/shifting actions would not be known until the spring of each year, when water acquisition decisions are made. The contribution to instream flows from agricultural return flows would be reduced in areas where cropland idling occurs. However it is unclear how this reduction was accounted for in the analysis of impacts on fish and wildlife resources and instream flows if the locations are unknown at this time. 23

CDFW recommends that the EIS/EIR explain how reduced agricultural return flows due to cropland idling/shifting were factored into the impact analysis.

Section 3.8.2.1.4 Page 3.8-38 to 3.8-40:

This section states that the magnitude and frequency of streamflow depletion in small streams were derived from a groundwater model (SACFEM2013) and then used to evaluate potential impacts to natural communities and special status vegetation and wildlife, since Central Valley Project and State Water Project operations could not be altered to offset any changes in small streams. However, the impacts of groundwater substitution on larger rivers and Central Valley Project/State Water Project reservoirs 24

Frances Mizuno
San Luis & Delta-Mendota Water Authority
December 1, 2014
Page 12

are carried from the groundwater model to the transfer operations model, which incorporates other changes in hydrology associated with cropland idling/shifting, reservoir releases and water conservations. This implies that changes in small stream hydrology associated with cropland idling/shifting were not included in the SACFEM2013 model.

24

CDFW recommends that the EIS/EIR explain how reduced agricultural return flows in small streams were accounted for in the SACFEM2013 groundwater model.

Section 3.8.2.4.1, Page 3.8-47:

This section describes impacts on natural communities in shallow groundwater areas in the North Delta; however it does not address impacts on wildlife. Some sensitive wildlife species require shallowly flooded areas (e.g., GGS and WPT) and impacts on these areas may substantially adversely affect such species.

25

CDFW recommends that the impact analysis not be solely based on whether vegetation will change. In shallowly flooded areas, a reduction of groundwater that lowers surface water elevation of wetlands should also be described, and impacts on wildlife that rely on shallow water analyzed. Mitigation should be provided if warranted.

In this section, the Assessment/Evaluation Methods for groundwater substitution transfers states that potential impacts of groundwater substitution on natural communities in upland areas was considered potentially significant if it resulted in a consistent, sustained depletion of water levels that were accessible to overlying communities (groundwater depth under existing conditions was 15 feet or less). A sustained depletion would be considered to have occurred if the basin did not recharge from one year to the next (Page 3.8-33). In a few locations in the North Delta associated with wetlands, groundwater elevations under existing conditions are less than 15 feet below ground surface and natural communities reliant on groundwater are more likely to be impacted. In these areas, the maximum reductions would be 0.3 to 0.8 feet, with full recharge. The Project would have a less than significant effect on natural communities and special-status plants because increases in drawdown would be too small to cause a substantial effect on vegetation that relies on groundwater. However, the EIS/EIR doesn't identify where these "few locations in the North Delta" are located or the natural communities that occur in these areas. Also, the less than significant determination is based upon the assertion that full recharge of the groundwater basin would always occur, thus only reducing groundwater levels by a maximum of 0.3-0.8 feet.

26

CDFW recommends that the EIS/EIR identify and discuss the areas in the North Delta and the natural communities associated with those areas in greater detail. Since the less than significant determination is based upon the assertion that full recharge of the groundwater basin will always occur, thus resulting in a max reduction of 0.3-0.8 feet

Frances Mizuno
 San Luis & Delta-Mendota Water Authority
 December 1, 2014
 Page 13

(too small to cause substantial effects), supporting historic groundwater elevation data should be provided. 26

Section 3.8.2.4.1, Page 3.8-60:

For Little Chico Creek, this section states, "[b]ecause flow reductions would be small and only during months when the creek is essentially dry, changes in stream flow would not substantially reduce natural communities or wildlife species habitat." However, taking water from a creek that is nearly dry could result in significant impacts on wildlife because some animals may not be able to tolerate prolonged episodes of dryness (e.g., WPT). 27

CDFW recommends that the EIS/EIR include an analysis of how the reduction of water during already dry times does not substantially reduce the availability of habitat for, or movement ability of, sensitive species.

Appendix I, Table I-1:

The Project proposes to fallow alfalfa and other row crops which Swainson's hawks (*Buteo swainsoni*, "SWHA"), a State-listed species, utilize to forage. However, the EIS/EIR does not disclose which croplands within foraging distance of SWHA nest trees will be fallowed, or the composition of these areas. Long term fallowing of these fields may result in a change or loss of pray base, prompting SWHA to leave the nest tree for longer periods to forage in other areas, which could negatively affect the species' reproductive effort. Therefore, the long term loss of foraging habitat could result in significant impacts on nesting SWHA by substantially reducing the number of an endangered, rare, or threatened species, and/or substantially adversely affecting a special status species (CEQA Guidelines, §15065 & Appendix G). 28

CDFW recommends that the EIS/EIR disclose which croplands in foraging distance of SWHA nest trees would be fallowed and the composition of these areas, analyze whether resultant impacts on SWHA could be significant, and provide for mitigation if warranted.

General:

Bureau of Reclamation contracts for Central Valley Project Improvement Act (CVPIA) Refuge Water Supply (RWS) delivery to USFWS, CDFW, and Grassland Water District managed wetlands all contain language in Article 7 allowing Project Water to be transferred, reallocated or exchanged to other refuges. CVPIA section 3406 subdivision (b)(3) requires development and implementation of a program to identify how the Secretary intends to utilize improvements in or modifications of project operation, including transfers, to fulfill the Secretary's obligations to deliver RWS. 29

Frances Mizuno
San Luis & Delta-Mendota Water Authority
December 1, 2014
Page 14

CDFW recommends that the EIS/EIR identify the total amount of RWS available from all sources north of Delta, and how these transfers are integrated into project operation. The program should address annual and long-term water transfer impacts that may adversely affect managed wetland water supply including endangered species recovery needs at managed wetlands; lack of sufficient dedicated water storage; timing of water delivery and use on shared conveyance systems; and potential increased groundwater use. CDFW is available to assist Bureau of Reclamation with any and all efforts to maximize use of water transfers in the furtherance of overall CVPIA RWS program objectives. These efforts should be coordinated with USFWS, Grassland Water District, and the Central Valley Joint Venture.

29

Mitigation Measures

Section 2.3.2.4, Pages 2-29 to 2-30:

Much of this section involves Environmental Commitments to protect GGS. These same commitments were largely used for 2014 transfers, and to a lesser degree, in previous years. Efforts to develop and refine the Environmental Commitments are ongoing, and studies to better understand GGS life history and distribution continue.

30

CDFW recommends incorporating any monitoring and analysis available from 2014 and previous transfer years where these and similar commitments were in place, and adaptively incorporating feedback as more information becomes available each year, including drought year impacts, as well as the following: incorporate results from ongoing studies on GGS population dynamics and distribution analysis; continue development of a long-term strategy and research framework; continue interagency coordinated efforts and investigate partnerships with water districts, non-governmental organizations, and academia; and include coordinated and collaborative development, including CDFW, to address GGS long-term conservation needs.

Section 3.1.4.1, Page 3.1-21:

This section states that a streamflow depletion factor (SDF) would be applied to mitigate potential water supply impacts from additional groundwater pumping due to groundwater substitution transfers. This is intended to offset the streamflow effects of the added groundwater pumping. The exact percentage of the SDF would be determined based on hydrologic conditions, groundwater and surface water modeling, monitoring information, and past transfer data. However, it is unclear what monitoring information and past transfer data has shown, and if previous percentages been adequate to mitigate for impacts.

31

CDFW recommends that the EIS/EIR include information on previous monitoring efforts; for example, what they entailed, past transfer data, the type of post-transfer analysis

Frances Mizuno
San Luis & Delta-Mendota Water Authority
December 1, 2014
Page 15

that was done, and what this analysis showed with respect to impacts on streamflow from increased groundwater pumping.

31

Section 3.3.4, Pages 3.3-88 to 3.3-91:

It is unclear whether mitigation measure GW-1 "Monitoring Program and Mitigation Plans" would reduce impacts on wildlife to less than significant because it appears that only wells would be monitored (as opposed to streams, wetlands, or sensitive species), and that impacts to wildlife would be reported by an outside entity. Monitoring would be coordinated with well operators and "other decision makers." The section states that if the seller's monitoring efforts indicate that the operation of wells for groundwater substitution pumping are causing substantial adverse impacts, the seller will be responsible for mitigating any significant environmental impacts that occur. However, it is unclear how this determination would be made.

32

CDFW recommends that the EIS/EIR analyze the need for monitoring of other water features and resources and include discussion of the types of monitoring and mitigation efforts conducted for past transfers, what will be duplicated for the Proposed Project, and any new/revised activities to ensure impacts on fish and wildlife resources are reduced to less than significant. The EIS/EIR should clarify who the "other decision makers" are and include representatives from CDFW and USFWS. Mitigation should also state that CDFW and USFWS would have authority to deem a monitoring and mitigation plan adequate or not for the purposes of issuing a water transfer agreement. The EIS/EIR should identify an entity with appropriate expertise to determine if Project activities are resulting in substantially adverse impacts and an adequate level of mitigation.

There are several EIS/EIR sections that conclude impacts on wildlife would be reduced to less than significant levels based on implementation of mitigation measure GW-1, which is intended to take corrective actions once substantial adverse impacts have been identified. However, these impacts appear to be based almost exclusively on changes in vegetation, which are not necessarily appropriate proxies for wildlife populations. Animals may starve or be exposed to greater predation well before signs of substantial impacts on riparian and wetland vegetation become evident. In addition, because there is no requirement for monitoring of vegetation changes, those signs would apparently have to be identified by agencies and organizations outside of the water transfers; therefore, there are no assurances they would be identified. Further, increases in flows are not always beneficial. For example, if flows are over 200 percent of normal during summer months, WPT nests could be flooded out, significantly reducing recruitment.

33

CDFW recommends that the EIS/EIR include a more comprehensive approach to evaluating impacts on fish and wildlife based on the habitat components required by

Frances Mizuno
San Luis & Delta-Mendota Water Authority
December 1, 2014
Page 16

each affected species including, but not limited to, plant community requirements. Mitigation should be proposed if warranted.

33

This section states the objectives of the monitoring and mitigation plan. However, these objectives are not fully consistent with the Draft Technical Information for Preparing Water Transfer Proposals (Bureau of Reclamation and Department of Water Resources 2013) and Addendum (Bureau of Reclamation and Department of Water Resources 2014).

34

CDFW recommends that the above statement be consistent with the specific mitigation and monitoring requirements of the aforementioned Draft Technical Information for Preparing Water Transfer Proposals and Addendum.

This section states that water transfer proponents would provide a final summary report to Bureau of Reclamation evaluating the impacts of the water transfer. The final report would identify transfer-related impacts on groundwater and surface water during and after pumping. However, past water transfer activities could inform anticipated impacts on fish and wildlife resources.

35

CDFW recommends that the EIS/EIR include the impacts past reports have shown in order to inform analysis of future transfers regarding impacts on the environment, and to avoid or mitigate any significant effects of proposed transfers.

General:

Water Code section 1018 states that landowners "shall be encouraged" to cultivate or retain non irrigated cover crops or natural vegetation to benefit waterfowl, upland game bird, and other wildlife habitat. The Department of Water Resources is currently addressing guidance and implementation regarding this language. CDFW recommends incorporating this information into the EIS/EIR so those proposing transfers would be compliant with these provisions.

36

Frances Mizuno
San Luis & Delta-Mendota Water Authority
December 1, 2014
Page 17

FUTURE COORDINATION

Questions regarding this letter or further coordination should be directed to Cathie Vouchilas, Environmental Program Manager, at (916) 651-1190 or Cathie.Vouchilas@wildlife.ca.gov.

Sincerely,



Helen Birss
Branch Chief

cc: State Clearinghouse
P.O. Box 3044
Sacramento, CA 95812-3044

ec: California Department of Fish and Wildlife

Sandra Morey, Deputy Director
Ecosystem Conservation Division
Sandra.Morey@wildlife.ca.gov

Cathie Vouchilas, Environmental Program Manager
Habitat Conservation Planning Branch
Cathie.Vouchilas@wildlife.ca.gov

Ryan Mathis, Senior Environmental Scientist (Supervisor)
Habitat Conservation Planning Branch
Ryan.Mathis@wildlife.ca.gov

Melanie Day, Senior Environmental Scientist (Specialist)
Habitat Conservation Planning Branch
Melanie.Day@wildlife.ca.gov

Curt Babcock, Environmental Program Manager
Northern Region (Region 1)
Curt.Babcock@wildlife.ca.gov

Jeff Drongeson, Environmental Program Manager
North Central Region (Region 2)
Jeff.Drongeson@wildlife.ca.gov

Frances Mizuno
San Luis & Delta-Mendota Water Authority
December 1, 2014
Page 18

Craig Weightman, Environmental Program Manager
Bay Delta Region (Region 3)
Craig.Weightman@wildlife.ca.gov

Jim Starr, Environmental Program Manager
Bay Delta Region (Region 3)
Jim.Starr@wildlife.ca.gov

Julie Vance, Environmental Program Manager
Central Region (Region 4)
Julie.Vance@wildlife.ca.gov

Paul Forsberg
Water Branch
Paul.Forsberg@wildlife.ca.gov

Frances Mizuno
San Luis & Delta-Mendota Water Authority
December 1, 2014
Page 19

References

Barlow, P.M., and Leake, S.A., 2012, Streamflow depletion by wells—Understanding and managing the effects of groundwater pumping on streamflow: U.S. Geological Survey Circular 1376, 84 p. (Also available at <http://pubs.usgs.gov/circ/1376/>)

980 NINTH STREET, SUITE 1500
SACRAMENTO, CALIFORNIA 95814
WWW.DELTACOUNCIL.CA.GOV
(916) 445-5511



DELTA STEWARDSHIP COUNCIL

A California State Agency

December 1, 2014

Chair
Randy Fiorini

Members
Aja Brown
Frank C. Damrell, Jr.
Phil Isenberg
Patrick Johnston
Larry Ruhstaller
Susan Tatayon

Mr. Brad Hubbard
U.S. Bureau of Reclamation
Planning Division
2800 Cottage Way
MP-410
Sacramento, CA 95825

Executive Officer
Jessica R. Pearson

RE: Proposed Long-Term Water Transfers EIS/R

Dear Mr. Hubbard:

The Delta Stewardship Council (Council) welcomes the opportunity to comment on the Long-Term Water Transfers Environmental Impact Statement/Environmental Impact Report (EIS/R) evaluating the potential impacts of alternatives to help address the Central Valley Project (CVP) water supply shortages (Project), being prepared jointly by the U.S. Bureau of Reclamation (Reclamation) and the San Luis & Delta-Mendota Water Authority (SLDMWA). The Council is an independent California state agency tasked with furthering California's coequal goals for the Delta through the implementation of the Delta Plan, a comprehensive, long-term Delta management plan. As defined in the California Water Code section 85054, the State's coequal goals include providing a more reliable water supply for California and protecting, restoring, and enhancing the Delta ecosystem. The Delta Plan highlights that north-to-south water transfers across the Delta can be an important tool for improving water supply reliability and includes several recommendations to identify and enhance opportunities for water transfers in furtherance of the coequal goals. The Plan also calls for improving water transfer procedures.

Even as the Council and Delta Plan support water transfers, they are only one important component for increasing water supply reliability and must be part of a larger suite of actions and projects. The Council has defined what the achievement of a more reliable water supply for California means:

- (a) Better matching the state's demands for reasonable and beneficial uses of water to the available water supply. This will be done by promoting, improving, investing in, and implementing projects and programs that improve the resiliency of the state's water systems, increase water efficiency and conservation, increase water recycling and use of advanced water technologies, improve groundwater management, expand storage,

"Coequal goals" means the two goals of providing a more reliable water supply for California and protecting, restoring, and enhancing the Delta ecosystem. The coequal goals shall be achieved in a manner that protects and enhances the unique cultural, recreational, natural resource, and agricultural values of the Delta as an evolving place."

– CA Water Code §85054

Mr. Brad Hubbard
U.S. Bureau of Reclamation
Planning Division
December 1, 2014
Page 2

and improve Delta conveyance and operations. The evaluation of progress toward improving reliability will take into account the inherent variability in water demands and supplies across California;

- (b) Regions that use water from the Delta watershed will reduce their reliance on this water for reasonable and beneficial uses, and improve regional self-reliance, consistent with existing water rights and the State's area-of-origin statutes and Reasonable Use and Public Trust Doctrines. This will be done by improving, investing in, and implementing local and regional projects and programs that increase water conservation and efficiency, increase water recycling and use of advanced water technologies, expand storage, improve groundwater management, and enhance regional coordination of local and regional water supply development efforts;
- (c) Water exported from the Delta will more closely match water supplies available to be exported, based on water year type and consistent with the coequal goal of protecting, restoring, and enhancing the Delta ecosystem. This will be done by improving conveyance in the Delta and expanding groundwater and surface storage both north and south of the Delta to optimize diversions in wet years when more water is available and conflicts with the ecosystem are less likely, and limit diversions in dry years when conflicts with the ecosystem are more likely. Delta water that is stored in wet years will be available for water users during dry years, when the limited amount of available water must remain in the Delta, making water deliveries more predictable and reliable. In addition, these improvements will decrease the vulnerability of Delta water supplies to disruption by natural disasters, such as, earthquakes, floods, and levee failures.

The 2009 legislation that created the Council also provided the Council with regulatory authority over certain types of activities undertaken by local or state agencies, called covered actions, and requires that covered actions be consistent with the Delta Plan as cited in Water Code section 85225 "A state or local public agency that proposed to undertake a covered action, prior to initiating the implementation of that covered action, shall prepare a written certification of consistency with detailed findings as to whether the covered action is consistent with the Delta Plan and shall submit that certification to the council." The Council developed new regulations governing covered actions, which became effective on September 1, 2013, and included them in the Delta Plan. The water transfers that are identified in EIS/R may be considered covered actions. Typically the lead CEQA agency determines if a proposed activity is a covered action and would then file a certification of consistency with the Council. The Council strongly encourages all state and local agencies who propose to approve, fund, or

Mr. Brad Hubbard
 U.S. Bureau of Reclamation
 Planning Division
 December 1, 2014
 Page 3

carry out an action in the Delta, consult with the Council as early in the project's development as possible, to ensure the project is consistent with the Delta Plan. 2

The Council submits the following comments on the EIS/R:

- **The Council suggests that SLDMWA, on behalf of its participating member agencies as well as the Contra Costa Water District (CCWD) and East Bay Municipal Utility District (EBMUD), file a certification of consistency with the Council on the program of water transfers covered by this EIS/R and indicate in the EIS/R that these transfers are covered actions.** Water Code section 85057.5(a) defines a covered action as:

...a plan, program, or project as defined pursuant to Section 21065 of the Public Resources Code that meets all of the following conditions:

1. *Will occur, in whole or in part, within the boundaries of the Delta or Suisun Marsh;*
 2. *Will be carried out, approved, or funded by the state or a local public agency;*
 3. *Is covered by one or more provisions of the Delta Plan;*
 4. *Will have a significant impact on the achievement of one or both of the coequal goals or the implementation of government-sponsored flood control programs to reduce risks to people, property, and state interests in the Delta.*
- 3

It appears that water transfers identified in the EIS/R meet the definition of a covered action. The preparation of the EIS/R indicates the Project meets the definition of a plan, program, or project as defined pursuant to Section 21065 of the Public Resources Code, the water transfers will take place at least partially in the Delta, will be undertaken by the participating agencies, will have a significant beneficial impact on water supply reliability, and implicate the following two regulatory policies that cover proposed water transfers through the Delta:

WR P1 (23 CCR section 5003) - Reduce Reliance on the Delta through Improved Regional Water Self-Reliance. This policy covers a proposed action to export water from, transfer water through, or use water in the Delta

WR P2 (23 CCR section 5004) – Transparency in Water Contracting. This policy covers:

1. With regard to water from the State Water Project, a proposed action to enter into or amend a water supply or water transfer contract subject to California Department of Water Resources Guidelines 03-09 and/or 03-10 (each dated July 3, 2003), which are attached as Appendix 2A; and

Mr. Brad Hubbard
U.S. Bureau of Reclamation
Planning Division
December 1, 2014
Page 4

2. With regard to water from the Central Valley Project, a proposed action to enter into or amend a water supply or water transfer contract subject to section 226 of P.L. 97-293, as amended or section 3405(a)(2)(B) of the Central Valley Project Improvement Act, Title XXXIV of Public Law 102-575, as amended, which are attached as Appendix 2B, and Rules and Regulations promulgated by the Secretary of the Interior to implement these laws.
- **The EIS/R should acknowledge the Delta Plan and its regulatory policies.** As previously discussed, the Council's regulations apply to covered actions where water suppliers export water from, transfer water through, or use water in the Delta; and covered actions that include entering into or amending water supply or water transfer contracts. Therefore, the Council, and its role with respect to covered actions, should be included in the appropriate sections of the EIS/R.
 - **The EIS/R "Purpose and Need/Project Objectives" section of the EIS/R should include a quantitative assessment of the need for water transfers to help identify other possible reasonable alternatives.** CEQA requires the project objectives describe the underlying need for and purpose of the project. The EIS/R states the Project's objectives as:
 - Develop supplemental water supply for member agencies during times of CVP shortages to meet existing demands.
 - Meet the need of member agencies for a water supply that is immediately implementable and flexible and can respond to changes in hydrologic conditions and CVP allocations.

However the EIS/R does not state what the water supply demand is for the participating agencies, nor does it state if that demand is changing over time, rather it merely identifies a list of potential buyers without any indication of the demands of those buyers. The EIS/R does describe how the member agencies' water supply from the CVP is variable, even with the use of water transfers. Table 1-1 indicates that the average CVP water supply allocation for the 2000 to 2014 period was 54% of contracted amounts for irrigation use and 83% of contracted amounts for municipal and industrial uses. Irrigation allocation was a full 100% only once during this period. Table 1-3 indicates that water transfers to SLDMWA member agencies occurred in 60% of the years between 2000 and 2014 though the amounts varied from several thousand acre-feet to over 169,000 acre-feet in 2009.

Are the participating agencies' demands variable and able to adjust to a decrease in supply? Then potential alternatives to reduce demand in lieu of increasing supply

Mr. Brad Hubbard
U.S. Bureau of Reclamation
Planning Division
December 1, 2014
Page 5

should also be considered. Or are the participating agencies' water supply demands constrained only by their contracts and the ability of the federal and state projects to deliver water? Understanding the demand on the Delta as a water supply is important. It is California's policy to reduce reliance on the Delta in meeting California's future water supply needs through a statewide strategy of investing in improved regional supplies, conservation, and water use efficiency. Each region that depends on water from the Delta watershed shall improve its regional self-reliance for water through investment in water use efficiency, water recycling, advanced water technologies, local and regional water supply projects, and improved regional coordination of local and regional water supply efforts (Water Code section 85021).

- **The EIS/R does not analyze the impacts of water transfers during periods when the state and federal water projects are unable to meet existing Delta water quality objectives.** In January 2014, Reclamation and the Department of Water Resources jointly filed a Temporary Urgency Change Petition (TUCP) for their water right permits and licenses for the state and federal water projects in response to extreme drought conditions in California. They requested temporary modification of requirements included in the State Water Resources Control Board's Revised Decision 1641; specifically the TUCP requested modifications to the requirement to meet the Delta Outflow Objective. The EIS/R does not analyze the potential impacts of water transfers on Water Quality (Chapter 3.2), Aquatic Resources (Chapter 3.7), Terrestrial Resources (Chapter 3.8), or any other potential Delta impact under these extreme conditions. Given that the current drought may continue into the period of time covered by the EIS/R and is likely to be a reoccurring event, the document should include an analysis of the impacts under extreme hydrologic conditions.

If you have any questions or would like to discuss the comments presented here, please feel free to contact me or my staff, Kevan Samsam at kevan.samsam@deltacouncil.ca.gov or (916) 445-5011. We look forward to engaging with Reclamation and its local partnering agencies on opportunities to further California's coequal goals and provide a more reliable water supply.

Sincerely,



Cindy Messer
Deputy Executive Officer

Cc: Frances Mizuno



State Water Resources Control Board

December 1, 2014

Brad Hubbard
Bureau of Reclamation
2800 Cottage Way, MP-410
Sacramento, CA 95825
bhubbard@usbr.gov

Frances Mizuno
San Luis & Delta-Mendota Water Authority
P.O. Box 2157
Los Banos, CA 93635
frances.mizuno@sldmwa.org

COMMENTS ON THE LONG-TERM TRANSFERS DRAFT ENVIRONMENTAL IMPACT STATEMENT/ENVIRONMENTAL IMPACT REPORT

The State Water Resources Control Board (State Water Board) staff appreciates the opportunity to review and provide comments on the Long-Term Transfers Draft Environmental Impact Statement/Environmental Impact Report (EIS/EIR). Comments on the Draft EIS/EIR are due on December 1, 2014. State Water Board staff conducted an initial review of the Draft EIS/EIR. Upon further review, the State Water Board may have additional comments.

1

State Water Board staff's comments are focused on groundwater issues associated with this project given the significant emphasis of the proposed project on groundwater substitution transfers and the recent California groundwater legislation that the State Water Board will have a role in implementing, specifically the Sustainable Groundwater Management Act of 2014 (SGMA). The SGMA requires development of local groundwater sustainability agencies and plans in certain basins, including most of the region covered by the proposed project, and requires sustainable groundwater management within 20 years of plan adoption. The legislation also provides the State Water Board direct authority to intervene when a groundwater basin is not sustainably managed.

Numerous water interests have long-relied on water transfers from the Sacramento Valley to meet their water supply demands. These transfers are in part made possible by groundwater substitution, and are important to the agricultural economy and municipal water supply needs of California. These transfers can be a critical component of long-term supply strategies for some water users. However, over-reliance on groundwater substitution can result in serious adverse impacts where the groundwater pumping occurs, and can result in depletion of groundwater resources, ecosystem impacts, subsidence, and water quality degradation, specifically during times of drought.

2

The Draft EIS/EIR finds that potentially significant impacts to groundwater resources could occur, but that with the proposed monitoring and mitigation program in place, these impacts would be less than significant. However, it is not clear whether these determinations are supportable. Specifically, the Draft EIR/EIS appears to underestimate the impact of the proposed project on local groundwater, does not appear to adequately account for the effect of

3

current drought conditions on groundwater availability, and reaches conclusions that do not appear to be supported by the available data. Specific comments are provided below.

3

Comment #1: The Sustainable Groundwater Management Act

As mentioned above, California State Assembly Bill 1739 and Senate Bills 1168 and 1319 were passed by the Legislature in August 2014, and were signed into law by Governor Brown in September 2014. The package of bills constitutes the SGMA of 2014. The SGMA provides a framework for improved groundwater management by local authorities, and becomes effective January 1, 2015. The legislation requires that local agencies sustainably manage groundwater basins over a long-term planning horizon, and allows for state intervention by the State Water Board when additional efforts are needed to protect groundwater resources. The SGMA defines sustainable groundwater management, provides local agencies with tools and authorities to manage basins, and sets a timeline for implementation. Local groundwater sustainability agencies (GSAs) must be formed by June 2017, and groundwater sustainability plans (GSPs) must be completed for basins with the greatest need by 2022. Basins that must adopt a GSP must achieve sustainability within 20 years of plan adoption.

4

Sections 3.1.1.2.2, 3.2.1.2.2, 3.3.1.2, and 3.8.1.2 of the Draft EIS/EIR should be updated to include a discussion of the SGMA, which will be implemented during the 10-year timeframe (2015-2024) of the proposed project. The SGMA will affect the proposed buyer and seller regions in regard to their groundwater management, land use, water demands, and water availability. The SGMA also requires that GSAs, address groundwater quality issues and possible effects on groundwater dependent ecosystems (GDEs) caused by groundwater extraction. The Draft EIS/EIR should also be updated to address the management programs and regulatory requirements established under the SGMA, specifically new groundwater data that will be made available as part of a GSP that could be integrated into the proposed monitoring and mitigation program. The Draft EIS/EIR should also be updated to require that any transfers follow requirements (monitoring, reporting, and if necessary limits on pumping) required by a GSA or GSP.

Comment #2: Data and Modeling Issues

The Draft EIS/EIR indicates that the Sacramento Valley is “flexible and can respond to changes in hydrologic conditions and Central Valley Project (CVP) allocations (Executive Summary section 1.2)” as opposed to the southern Central Valley where there is a dire need for water. This conclusion appears to be based on an analysis of existing data primarily consisting of Department of Water Resources (DWR) hydrographs, supply availability data provided from potential sellers, and modeling results from the SACFEM2013 model. The State Water Board has the following comments regarding this assessment.

1. The analysis should include recent data showing significant groundwater depletions in the Sacramento Valley. There are several data sets and reports available from DWR that should be included in the analysis of groundwater availability, but are not. DWR has published a drought report (DWR, April 30th, 2014) showing groundwater declines for significant portions of the Sacramento Valley. The Draft EIR/EIS should include an analysis of how additional water extractions could affect local groundwater levels given the current groundwater elevations and drought status.

5

Section 3.1.1.3, page 3.1-5, describing the existing conditions of water supplies available for transfer should be updated to include groundwater data (e.g., DWR's California Statewide Groundwater Elevation Monitoring (CASGEM), basin prioritization results, etc.) to support the stated assumptions of the quantity of groundwater available in seller areas for transfer through groundwater substitution.

5

2. The groundwater quality analysis should include additional assessments of groundwater quality, including the State Water Board's AB2222 report (Communities that Rely on Contaminated Groundwater Source for Drinking Water, available at: http://www.swrcb.ca.gov/water_issues/programs/gama/ab2222/index.shtml), GeoTracker data, and GeoTracker GAMA data to assure that potential impacts from mobilizing contaminant plumes and other groundwater quality impacts are adequately evaluated.

6

3. The statements in sections 3.2.2.4.1 page 3.2-28, and section 3.2.2.5.1, page 3.2-42, that "groundwater quality in the [seller service] area is generally good and sufficient for municipal, agricultural, domestic and industrial uses" is potentially overly broad. The conclusion does not account for current groundwater quality monitoring, including monitoring data from wells in the proposed seller areas that have been identified to be within close proximity of nitrate contamination.

In order to accurately reflect the highly variable groundwater aquifer properties such as hydraulic conductivity and transmissivity, it is necessary to incorporate all well information within a data set. Most aquifers are neither homogeneous nor isotropic, and the hydraulic conductivity can be characterized differently in all directions. If the intent of the modeling analysis is to simulate the effects of the operation of high-productivity irrigation wells screened within the major producing zones, then it would be prudent to characterize these production zones with as much information as possible to avoid bias. In Section D.3.6, paragraph 3, the Draft EIS/EIR states that "all test data from wells that reported a well yield below 100 gallons per minute were eliminated from consideration, as were the test data from wells with a total depth less than 100 feet." Are the criteria for filtering the well test data mutually exclusive or inclusive? If a well had low yield data and was located 600 feet below the surface, then it should be included in the data set. This filtered data set contains one of the most important parameters in the model and can influence flow direction and velocities and should be characterized as accurately as possible. As a result of filtering the data, the results do not reflect heterogeneous/anisotropic conditions seen in the subsurface. These subtle differences in the subsurface are what comprise the hydrodynamic character of each aquifer and without this data, the conclusions drawn by the model are potentially unreliable. The Draft EIS/EIR should have a better description of model parameters and inputs, and the potential effects that inclusion/exclusion of certain types of data could have on model results.

7

4. The project model is based on an abbreviated calibration set from 1970 to 2003 that does not appear to represent current water use, precipitation, and drought conditions or future climate change scenarios, which are generally drier. Groundwater recharge in the northern part of the Central Valley is below normal due to drought conditions.

8

Consequently, it could take several years to recharge the volume of water exported during a single year of transfers. This project proposes to export as much as 512,000 acre-feet of water annually. With the current drought, basin yield for these projects could be well below the amount used for the project model. As such, the interpretations based on the model may underestimate impacts to the area.

Section 3.1.2, page 3.1-14, describing the assessment methods used to determine the environmental impacts associated with the project should be revisited. The water year time period (1970-2003) used for the model fails to account for current environmental conditions and water use trends. For example, the model assumes that water transfers occur in 12 out of the 33 year time period. However, the State Water Board's Division of Water Rights' Water Transfer Program records indicate that water transfers have occurred for the last six consecutive years of the current program's record (2009-2014). It is reasonable to expect that establishing a long-term transfer program would facilitate a higher frequency of water transfers, which would result in more frequent groundwater substitution transfers.

In addition, known conditions do not appear to match what is shown in the Draft EIS/EIR. There are many wells in the northern Sacramento Valley that have cones of depression that cover large areas and are not accounted for. DWR maps show groundwater depletions in excess of 20 feet for shallow, intermediate, and deep groundwater aquifers from spring 2004 to spring 2013. The set of wells used to calibrate the model do not include wells that have undergone considerable groundwater elevation losses in excess of 20 feet within the last 10 years. The DWR potentiometric and groundwater elevation maps were created using over 200 wells around the northern Sacramento Valley. Choosing well locations and values that are not located within the cone of depression areas are not reflective of current conditions and will sway model results and how the system responds to future groundwater extraction.

Comment #3: Monitoring and Mitigation

The Draft EIS/EIR references a Draft document titled Technical Information for Preparing Water Transfer Proposals and Addendum for providing guidance on the development of proposals for groundwater substitution water transfers; however, information on these documents were not described in detail. Based upon the information provided in the Draft EIS/EIR, there are several additions and clarifications that could strengthen the Mitigation and Monitoring Program (M&MP):

1. Groundwater elevation data captured by the sellers should be required to be submitted to DWR's CASGEM Program, and sellers should be required to submit their information to any GSA for development of the basin's GSP. Although the sellers may be able to address groundwater depletions within their own service areas, the groundwater extractions may influence areas far outside the boundaries of the seller agencies. The only way to assess basin-scale impacts of exporting hundreds of thousands of acre-feet of water is a comprehensive basin-scale monitoring program. Eventually, development of GSAs will produce basin-scale data repositories. However, those GSAs have not yet been developed. In the interim, CASGEM offers an existing method to compile and analyze the data. As an alternative, the sellers may submit the data to the State Water Board's GeoTracker GAMA system. Local water districts should also be involved in

8

9

10

monitoring and mitigation processes so they can provide oversight on the entire area, manage disputes, and activate any mitigation processes.

10

2. It is unclear why groundwater elevation monitoring reports should be submitted only to Reclamation. DWR, local agencies (e.g., GSAs, counties, local water districts, others), and the State Water Board all have regulatory mandates to protect and manage groundwater resources. At a minimum, the data provided through the monitoring reports should be made available to any public agency with local authority to manage groundwater. We suggest making the reports available on a publicly-accessible website or database.

11

3. To ensure that impacts to water quality and other users do not occur as a result of this project, the M&MP program should require: sellers to incorporate existing water quality data from CASGEM, the State Water Board's AB 2222 report, GeoTracker GAMA, and GeoTracker; should require an analysis of known potential contaminant sites; and should require setbacks from known contaminant sites or plumes. Where appropriate, the programs should include an analysis of well screen intervals, water source, and potential contaminants in the area. The State Water Boards' GeoTracker system shows the location of thousands of leaking underground storage tanks, including sites within the seller's service areas. Leaking tanks typically affect the shallowest portions of an aquifer. Table 3.3-3 shows that many of the proposed sellers' wells are located in relatively shallow portions of the aquifer. For example, The Natomas Central MWC estimates that wells pumping at 5,500 gallons per minute (gpm) are located at depths as shallow as 150 feet below the ground surface. A contaminant can quickly and easily migrate from the surface to a depth of 150, particularly where the local geology is hydrogeologically conducive for rapid infiltration.

12

4. The mitigation component is vague, and does not identify trigger points that activate a mitigation process. Nor does the mitigation plan identify who will require the mitigation, who will oversee the mitigation, and who will ensure that mitigation is completed. The document, in Section 3.3.4.1.3, describes a scenario where the seller would be responsible for self-initiating and managing the mitigation plan. Leaving the sellers to self-mitigate is a potential conflict of interest, and may result in scenarios where adverse impacts to groundwater and other resources go unaddressed.

13

The M&MP requirements proposed in the Draft EIS/EIR (section 3.3.4.1, page 3.3-88) do not consider all local regulations. Of the 28 proposed seller agencies, 7 agencies have existing Groundwater Management Plans (GWMPs), which include M&M requirements that may be duplicative. The SGMA will require that additional seller districts be part of a GSP (which will replace any existing GWMPs). As with GWMPs, the GSPs will contain local M&MP requirements. The Draft EIS/EIR M&MP should be rewritten to ensure that proposed seller agency activities meet the regulatory requirements in the existing GWMPs or future GSPs.

14

Comment #4: Groundwater/Surface Water Interactions and Groundwater Dependent Ecosystems

Section 3.1.2.4 makes assumptions regarding groundwater availability for groundwater substitution transfers in seller areas that may misrepresent existing groundwater conditions. While the Draft EIS/EIR acknowledges that groundwater/surface water interactions exist, and that groundwater can contribute an important percentage of stream baseflow, the document does not account for potential impacts to surface waters in the sellers' areas that are caused by significant groundwater depletion. As written, the Draft EIS/EIR implies that natural in-stream groundwater recharge has a direct impact on streamflows, but does not consider how groundwater depletion in the sellers' area might reduce surface water baseflow. Additionally, the Draft EIS/EIR assumes that current groundwater levels are being sustainably managed and that there is adequate groundwater available to ensure reliable water sources for the proposed groundwater substitution transfers. The Draft EIS/EIR makes this assumption without demonstrating that current conditions and ongoing practices are not impacting groundwater dependent ecosystems.

15

The Draft EIS/EIR includes a series of maps (figures 3.3-26 through 3.3-31) showing simulated change in groundwater head, for different depths, for the 1976 and 1990 transfer seasons. Those maps are illustrative, but do not represent current conditions. As noted above, transfers have taken place for the last six consecutive years. In combination with information that a single year's worth of drawdown could reduce shallow-aquifer levels by 15 to 20 feet (e.g., Figure 3.3-31, near the Cordua Irrigation District), there is significant concern that continued transfers will harm groundwater dependent ecosystems. Consecutive years of transfers could lower groundwater elevations to the point that ecosystems (including wetlands, springs, and streams) are disconnected from groundwater, causing harm to local species.

16

Section 3.8.2.1, page 3.8-31, describing the assessment methods used to determine transfer effects on groundwater dependent ecosystems leaves out critical information and appears to make incorrect assumptions in assessing harmful effects to groundwater-dependent ecosystems. (Section 3.8.2.1). The water year time period (pre-2003) used for the model, does not account for current environmental conditions and water use trends. Furthermore, the assumption that there will be no groundwater/surface water interaction where pre-transfer water levels are already more than 15 feet below ground surface is not supported. Baseflows may be disconnected to the stream course in one area of the catchment, but discharge to the land surface as streamflow or a spring in other areas of the basin. In addition, the logic appears to be circular, since pumping related to the proposed transfers can drive groundwater elevations to depths greater than 15 feet below ground surface.

17

Section 3.8.2.1 also discusses impacts to species that could occur where groundwater dependent ecosystems are cut off from their water source due to transfer-related pumping. The assumption that impacted species will be able to adjust to lowering groundwater levels in a single water year is not supported (Section 3.8.2.1.1, page 3.8-31). The 15-foot cutoff is based on a model run that uses decade-old data, and does not account for regional or basin specific geology that defines the extent of surface water-groundwater interactions.

18

The Draft EIS/EIR appears to disregard potential effects to groundwater dependent ecosystems that could occur in the sellers' area. A more thorough discussion of the effects of groundwater extraction on ecosystems in the sellers' area should be included in section 3.8.2.4, page 3.8-46. The associated impacts to the groundwater dependent ecosystems are determined to be not significant with the implementation of Mitigation Measure GW-1. However, the mitigation

19

appears to be inadequate (where the primary mitigation action is to reduce groundwater pumping). To prevent negative impacts to groundwater dependent ecosystems, the mitigation plan should require preventative actions rather than reactive approaches to ensure impacts do not occur.

19

Comment #5: Groundwater Levels in the Buyers' Area

In Section 3.3 (Table 3.3-7, page 3.3-86 and again on page 3.3-87), the Draft EIS/EIR states that transfers could increase groundwater levels, eliminate or minimize land subsidence, and improve groundwater quality in the Buyer Service Area by reducing groundwater pumping during shortages. This statement is potentially misleading. In order to show that the transfers would increase groundwater levels (presumably through percolation of excess irrigation water, and/or conjunctive recharge), the Draft EIS/EIR should include a water balance for the buyer's areas. In all likelihood, the volume of the transfer would need to be significantly greater than the amounts proposed for long-term transfer in order to replace the amount of groundwater that is currently extracted to meet agricultural demands in the buyer's region. For example, the Draft EIS/EIR states that the average annual groundwater production in the San Joaquin basin is 0.9 million acre feet (Section 3.3, page 3.3-41), which is more than the sum of the proposed transfers. It is not plausible to assume that transfer water will solve the San Joaquin groundwater depletion issues, especially considering precipitation and mountain-front recharge amounts have decreased in response to the drought. While the transfers may slow the rate of groundwater decline in the buyer's area, there is no basis to state that the application of the transfer water alone will raise groundwater levels. Similarly, while the transfers may temporarily slow subsidence, unless the transfer water raises groundwater elevations above historic lows the additional water is unlikely to halt subsidence (although it may slow locally significant rates). It would be more productive to show a simple water balance for the respective buyer's areas, with a discussion of how much groundwater pumping, in addition to transfer water, is needed to sustain current and projected agricultural practices.

20

Please contact Erik Ekdahl at (916) 341-5316 or erik.ekdahl@waterboards.ca.gov, if you have any questions or would like to discuss this matter further.

Sincerely,

ORIGINAL SIGNED BY

Diane Riddle, Manager
Hearings & Special Program Section
Division of Water Rights



BOARD OF SUPERVISORS

ADMINISTRATION CENTER
25 COUNTY CENTER DRIVE, SUITE 200 - OROVILLE, CALIFORNIA 95965
TELEPHONE: (530) 538-7631

BILL CONNELLY
First District

LARRY WAHL
Second District

MAUREEN KIRK
Third District

STEVE LAMBERT
Fourth District

DOUG TEETER
Fifth District

November 25, 2014

Brad Hubbard
Bureau of Reclamation
2800 Cottage Way, MP-410
Sacramento, CA 95825

Frances Mizuno
San Luis & Delta-Mendota Water Authority
P.O. Box 2157
Los Banos, CA 93635

Re: Long-Term Water Transfers Program Draft Environmental Impact Statement/Environmental Impact Report (EIS/EIR)

Dear Mr. Hubbard and Ms. Mizuno:

Butte County appreciates the opportunity to provide comments on the Environmental Impact Statement/Environmental Impact Report (EIS/EIR) for the proposed Long-Term Water Transfers Program. Butte County and its surrounding region have a vested interest in assuring that the Long-Term Water Transfers Program has the least impact upon the community, agricultural economy and environment. Our region's water resources provide the life blood for our agricultural-based communities, economy and environment. Much of our local water supply comes from the various groundwater basins throughout the region that are recharged through these creeks and rivers.

1

We are troubled by the short amount of time afforded to provide comments on the EIS/EIR. It has been almost four years since the Bureau released the draft EIS/EIR scoping document. The Butte County Board of Supervisors submitted comments on the scoping document on February 22, 2011. Three years later the Bureau released a draft EIS/EIR, yet only provided the public 60 days to review, analyze and comment. The community has a strong interest in the Long-Term Water Transfers Program. So, in fairness, the Bureau of Reclamation (Bureau) should extend the comment period for at least ninety days.

Based on our preliminary review, we believe that the EIS/EIR is seriously flawed and will need to be revised and recirculated. The relied upon data is outdated, incomplete and selectively chosen. The result is that the EIS/EIR fails to meet the requirements of the National

2

Environmental Policy Act and the California Environmental Quality Act. Again, due to the inadequate amount of time afforded to comment, the comments provided by the Butte County Board of Supervisors do not reflect a full review of the document.

2

The Long-Term Water Transfers Program purports to assist water users south of the Delta with immediate implementable and flexible supplemental water supplies to alleviate shortages. The project objectives claim that shortages are expected due to hydrologic conditions, climatic variability, and regulatory requirements. Project justification intends to address unforeseen, short-term water supply challenges. The reality is that the circumstances facing the water users south of the Delta are neither short-term nor unforeseen. These water supply reliability challenges are baseline conditions that must be addressed at the local and regional level. Ironically, water users north of the Delta face similar challenges in terms of hydrologic conditions and climatic variability, but the EIS/EIR inadequately assesses these limitations. The project intends to establish a long-term water transfer program to meet the current and future demands south of the Delta, not based on any viable criteria.

3

Even though the EIS/EIR identified significant impacts in the Sacramento Valley, the methodology underestimated those impacts. The EIS/EIR identified significant impacts including lower groundwater elevations, changes to groundwater quality, reduction in groundwater recharge and decrease flows in surface water. However, it fails to take into account that the reduction in stream flows and the lowering of Lake Oroville that will harm the local economy. In addition to underestimating these impacts, the mitigation measures in the EIS/EIR are not viable and will not mitigate the significant impacts. The following specific examples highlight the flaws in the EIS/EIR and provides justification for a revised and recirculated EIS/EIR.

4

First, the description of the regulatory setting in Chapter 3 – Groundwater (section 3.3.1.2) is incomplete, misleading and inaccurate. The document makes no mention of the recently enacted Sustainable Groundwater Management Act. The implementation of the Sustainable Groundwater Management Act will occur during the ten year period of the water transfer program. The Sustainable Groundwater Management Act will affect the buyer and seller regions in regard to their groundwater management, land use, and water demands. The data and management programs developed through the Sustainable Groundwater Management Act will change the assumptions in the EIS/EIR.

Second, the EIS/EIR must reference and acknowledge Area of Origin provisions in the Water Code. Specifically, the EIS/EIR must reference Water Code 85031, which states, “*This division does not diminish, impair, or otherwise affect in any manner whatsoever any area of origin, watershed of origin, county of origin, or any other water rights protections, including, but not limited to, rights to water appropriated prior to December 19, 1914, provided under the law. This division does not limit or otherwise affect the application of Article 1.7 (commencing with Section 1215) of Chapter 1 of Part 2 of Division 2, Sections 10505, 10505.5, 11128, 11460, 11461, 11462, and 11463, and Sections 12200 to 12220, inclusive.*” Honoring area of origin water rights is consistent with state water policy and a foundational element to California’s water future. In addition, the EIS/EIR should also discuss how the project complies with SB1X, which calls for a reduced reliance on the Delta and to promote regional water supply reliability.

5

The description of the local regulatory setting in the EIS/EIR failed to reference the Butte County Groundwater Conservation Ordinance (Chapter 33 of the Butte County Code), which Butte County voters overwhelmingly adopted in 1996. The Groundwater Conservation Ordinance requires a permit for water transfers that include a groundwater substitution component. The primary purpose of this Ordinance is to ensure that an adequate independent environmental review occur and to assure that groundwater resources would not be adversely affected (i.e., overdraft, subsidence, saltwater intrusion) or result in uncompensated injury to overlying groundwater users and others. Additionally, the process of the Groundwater Conservation Ordinance brings a measure of transparency and public involvement that should be part of any water governance process. It is imperative that the proposed program adhere to the spirit and intent of local groundwater ordinances that have been codified since the Drought Water Bank held in the early 1990s. In this regard, the program needs to recognize that groundwater basins can extend across multiple administrative jurisdictions. Groundwater substitution transfers that occur in Colusa or Glenn counties have the potential, over the long term, to draw down groundwater sources shared with Butte County.

5

The EIS/EIR (Chapter 3, p. 21) includes a limited description of groundwater production, levels and storage in the Sacramento Valley. The section fails to report on the extensive data and analysis of groundwater conditions in this area. The EIS/EIR bases its analysis on a few selected wells, and provides a generalized description of regional groundwater conditions based on those wells. What is most troubling is the conclusion that the Sacramento Valley groundwater trends indicate that “wells in the basin have remained steady, declining moderately during extended droughts and recovering to pre-drought levels after subsequent wet periods.” This conclusion misrepresents the reality of groundwater conditions in the Sacramento Valley. The EIS/EIR acknowledges that one of the selected wells, 21N03W33A004M, shows a steady decline but discounts this data as an anomaly. The EIS/EIR fails to adequately take into consideration that current groundwater conditions are being impacted beyond routine seasonal fluctuations and does not account for projected impacts from climate change. In some areas, BMO alert or trigger levels have been reached. There are a number of areas that have a steady decline in groundwater elevation unrelated to drought conditions. The EIS/EIR should have included a more comprehensive analyses of groundwater conditions and locally adopted Basin Management Objectives (BMO), clearly describing how BMOs will be utilized and how the program will address current conditions.

6

In addition to misrepresenting groundwater elevation data, the EIS/EIR also willfully ignored and misrepresented the current condition of streams and creeks in the Sacramento Valley. The Sacramento Valley subsidence monitoring data are readily available through the Department of Water Resources and the EIS/EIR should have included that data. For specific data and analysis of Butte County groundwater conditions, we invite the Bureau to review the annual Groundwater Status Report at:

<http://www.buttecounty.net/waterresourceconservation/GroundwaterStatusReports.aspx>.

We have concerns over the modeling methodology and the resultant appraisal of that data. Unfortunately, the limited amount of time afforded to comment precludes Butte County from conducting an in-depth analysis. However, a preliminary review of the modeling data raised a number of questions. One is the implication of the limited dataset to conduct the CalSim II

7

modeling analyses. The choice of data used to establish baseline conditions for the SACFEM2013 analysis is critical to identifying the impacts of the study. The reliance on data from 1970 to 2003 fails to take into account current conditions and trends. For example, the analysis of the data used lead to an assumption that 12 out of 33 years would result in groundwater substitution transfer events. However, recent experience (2000-2014) has shown that transfer programs have actually occurred in 9 of 15 years; more than one and a half times that of the analysis. A reasonable expectation is that having an established Long-Term Transfer Program would facilitate a higher frequency of water transfers and that, in turn, groundwater substitution transfers would occur in most years. The discrepancy between calculated expectations versus actual occurrences demonstrates an obvious fundamental flaw in the EIS/EIR that requires revision.

7

One of the most egregious flaws with the EIS/EIR is how the impacts from groundwater substitution transfer programs are identified and mitigated. According to the EIS/EIR (p. 3.3-61), “an impact would be potentially significant if implementation of groundwater substitution transfers or cropland idling would result in:

- A net reduction in groundwater levels that would result in adverse environmental effects or effects to non-transferring parties;
- Permanent land subsidence caused by significant groundwater level decline.
- Degradation in groundwater quality such that it would exceed regulatory standards or would substantially impair reasonably anticipated beneficial uses of groundwater;”

Based on our preliminary analysis, the EIS/EIR fails to adequately assess the impacts from groundwater substitution transfer programs. The EIS/EIR underestimates the effects and fails to adequately mitigate those effects in regards to determining whether there is a net reduction in groundwater levels that would result in adverse environmental effects or effects to non-transferring parties. As previously shown, the assumption that groundwater substitution would occur on a limited basis was false, so the simulated changes in water table elevations can only be assumed to be grossly underestimated. Additionally, the EIS/EIR conclusion that most wells in the Sacramento Valley are deeper than the resulting groundwater elevations is not true. In actuality, most of domestic wells are less than 100 feet. The combination of these two erroneous conclusions resulted in the EIS/EIR completely failing to assess the potential impacts of the groundwater substitutions to shallow domestic wells. The lowering of groundwater elevations from groundwater substitutions during a drought period would likely make a number of domestic wells inoperable. The conclusion that shallow wells would only see a reduction in yield and not go “dry” is equally untrue. During the past two drought periods, Butte County and the Sacramento Valley have responded to numerous incidents of domestic wells failing. The EIS/EIR must recognize and analyze how the Long-Term Transfer Program will contribute and exacerbate the impacts of a natural disaster to those who rely on domestic wells.

8

The EIS/EIR (Chapter 3.7) identified that the Long-Term Water Transfers Program will impact local streams and jeopardize critical ecosystems. Of particular concern is the calculated stream flow reduction in Little Chico Creek of more than 1 cubic foot per second and a reduction of more than 10%. The EIS/EIR categorized the impact to Little Chico Creek as a significant impact. Unfortunately, the EIS/EIR underestimated the impacts and relied on outdated

9

information again. As mentioned previously, the EIS/EIR underestimates the frequency of groundwater substitution events, and the data relied upon for analyses are outdated. The stream gaging data along Little Chico Creek was based on data from 1976 to 1995, and the CalSimII modelling results did not include data after 2003. Because the stream data relied upon in the EIS/EIR do not reflect current baseline conditions in the Sacramento Valley, it raises significant doubts to the validity of the conclusion that the resultant reduction in flows, particularly in Little Chico Creek, would not impact spring-run Chinook salmon. Therefore, the Bureau must reevaluate the environmental impacts to streams and aquatic ecosystems based on current data.

9

The environmental analysis identified a number of significant impacts requiring mitigation. Unfortunately, the proposed mitigation measures, particularly Mitigation Measure GW-1: Monitoring Program and Mitigation Plans, will not mitigate adverse environmental effects or minimize potential effects to other legal water users. The EIS/EIR, as written, does not include criteria or standards that must be met to mitigate significant impacts and the Monitoring Program (3.3.4.1.2) has vague and subjective standards for what constitutes as an acceptable monitoring network. The EIS/EIR should assess the existing monitoring network and identify monitoring gaps based on the locations of potential willing sellers.

10

Another fundamental flaw is the expectation that potential sellers be required to develop a mitigation plan. The initial premise of the mitigation plan is that the seller's monitoring program would indicate whether the operation of wells for groundwater substitution pumping are causing substantial adverse impacts. Unfortunately, because the definition of substantial adverse impacts is not defined, the process to monitor and mitigate third party impacts lacks clarity. First, the Long-Term Water Transfers Program must define the specific parameters for what constitutes substantial adverse impacts. Then the Long Term Water Transfers Program must have an unambiguous, transparent, locally vetted dispute resolution program. It is imperative that the Long-Term Water Transfers Program recognize that potential impacts associated with the transfer of water from the Sacramento Valley need to be addressed through this type of approach.

The description of potentially significant unavoidable impacts (Section 3.3.5) contains inaccurate statements and misleading information. First, it is unclear why the Northern Sacramento Valley Integrated Regional Water Management Plan (NSVIRWMP) is included in this section. It appears that the Bureau does not understand the policy and governance of the NSVIRWMP. The NSVIRWMP does not have programs or project priorities that could be construed as potentially causing significant unavoidable impacts. Similarly, the reference to and characterization of the Tuscan Aquifer Investigation Project is inaccurate. The Tuscan Aquifer Investigation Project was a scientific project that intended to improve the understanding of the recharge characteristics of the lower Tuscan Formation and the interconnectedness of the basin. The characterization that the Tuscan Aquifer Investigation Project "would increase pumping within (or near) the Seller Service Area" is categorically false. If the Bureau had taken the time to review the data and reports from the Tuscan Aquifer Investigation, they might have improved their analysis by using current scientific data. It is apparent that they chose not to do so and mischaracterized a scientific investigation. We demand that the Bureau remove the reference to the Tuscan Aquifer Investigation Project.

11

Finally, we have questions and concerns regarding the designated lead agencies in the EIS/EIR. The Department of Water Resources (DWR) should be designated as a lead agency rather than as a Responsible Agency. A number of the participating agencies are State Water Project (SWP) Contractors regulated by DWR and the conveyance for the project will use SWP facilities under the jurisdiction of DWR. One of the risks and uncertainties identified in Chapter 2 of the EIS/EIR was the ability to coordinate water transfers with DWR. Additionally, we fail to understand why the San Luis & Delta-Mendota Water Authority (SLDMWA) is the only lead water agency. Other water agencies have responsibilities equal to those of SLDMWA. The roles and responsibilities of participating agencies (Section 1.5) is inadequate and vague. The EIS/EIR fails to justify the choice of the SLDMWA as the sole lead agency when there is such a clear conflict of interest between the SLDMWA and the northern Sacramento Valley counties that overlie the groundwater sources that will contribute to groundwater substitution transfers. The document fails to provide a rationale for not including other water agencies named in the EIS/EIR as lead agencies.

12

The magnitude of the proposed program is daunting and raises considerable concerns. In our comments on the scoping of the EIS/EIR in 2011, we surmised that an adequate EIS/EIR may not be possible based on the length and breadth of the proposed program. It appears that our concerns are true.

13

In conclusion, we cannot stress enough that actions through the Long-Term Transfer Program could have grave economic and environmental consequences in the Sacramento Valley that must be addressed. The EIS/EIR woefully fails to meet minimal environmental assessment standards, provides misleading statements and avoids including a complete, current, data set. We recommend that the Bureau of Reclamation extend the comment period for at least 90 days to allow a more complete review. Upon receipt of the comments, the Bureau must remedy the deficiencies in the EIS/EIR and recirculate it for comment.

14

Thank you for your consideration.

Sincerely,



Doug Teeter, Chair
Butte County Board of Supervisors



COMMUNITY DEVELOPMENT
DEPARTMENT

411 Main Street - 2nd Floor (530) 879-6800
P.O. Box 3420 Fax (530) 895-4726
Chico, CA 95927 http://www.ci.chico.ca.us

December 1, 2014

Brad Hubbard
Bureau of Reclamation
2800 Cottage Way, MP-410
Sacramento, CA 95825
Sent via Email to bhubbard@usbr.gov

Frances Mizuno
San Luis & Delta-Mendota Water Authority
842 6th Street
Los Banos, CA 93635
Sent via Email to frances.mizuno@sldmwa.org

Re: Comments on the Long-Term Water Transfers Draft Environmental Impact
Statement/Environmental Impact Report (EIS/EIR) – Public Draft

Dear Mr. Hubbard and Ms. Mizuno:

This letter is to provide the City of Chico's comments regarding the adequacy of the EIS/EIR analysis of the environmental effects, and mitigation for, water transfers from water agencies in northern California to water agencies south of the Sacramento-San Joaquin Delta and in the San Francisco Bay Area.

Through its General Plan, it is Chico's policy to oppose regional sales and transfers of local groundwater, including water export contracts, and the EIS/EIR should acknowledge and clearly highlight such inconsistency with a General Plan (CEQA Guidelines § 15125(d)). The Tuscan aquifer is the primary groundwater basin underlying and providing municipal and agricultural water to Chico and its Planning Area. It's for this reason that the City opposes transfers of local groundwater in the long-term interest of a safe and reliable municipal water supply, and to support the regional economy and the environment.

Beyond our opposition to the transfer project as a matter of policy, our specific concerns regarding the EIS/EIR include:

- While 60 days is the legal minimum for public review and comment on a Draft EIS/EIR, it is not an appropriate review time for such an important and voluminous document that attempts to analyze and mitigate the potential impacts of a six county, 10-year water transfer program. We request that the comment period be extended for at least an additional 90 days.
- The Federal Register notice for the EIS/EIR states that “[t]ransfers of CVP supplies and transfers that require use of CVP or SWP facilities are subject to review by Reclamation and/or DWR in accordance with the Central Valley Project Improvement Act of 1992, Reclamation's water transfer guidelines, and California State law. Pursuant to Federal and State law and subject to separate written agreement, Reclamation and DWR would facilitate water transfers involving CVP contract water supplies and CVP and SWP facilities” (emphasis added). CEQA Guidelines Section 15367 and Section 15051 suggest that given the prominent role that DWR plays in the proposed water transfers, it is not proper that SLDMWA is the Lead Agency for the purposes of CEQA. A number of the participating water agencies are State Water Project contractors

regulated by DWR and the conveyance for the project will use SWP facilities under the jurisdiction of DWR.

- The project objectives for the EIS/EIR suggest that water shortages are expected due to hydrological conditions, climatic variability, and regulatory requirements. The project's justification therefore is to address unforeseen, short-term water supply challenges. The reality, however, is that the water supply challenges facing the water users south of the Delta are not unforeseen or short-term --- they are simply a created existing condition. The project objectives for the EIS/EIR need to be revised to accurately reflect the project's true purpose --- establishing a long-term water transfer program to address a created and growing water supply reliability challenge south of the Delta.
- The EIS/EIR (Chapter 3) provides an incomplete description of groundwater production, levels, and storage in the Sacramento Valley. In particular, the chapter fails to report on the extensive data and analysis of groundwater conditions in Butte County. The EIS/EIR bases its analysis on a few selected wells, and provides a generalized description of regional groundwater conditions based on those wells. The EIS/EIR fails to acknowledge data available from Butte County's Department of Water and Resource Conservation showing that current groundwater conditions are being impacted beyond routine seasonal fluctuations. In Butte County, Groundwater Basin Management Objective (BMO) alert levels have been reached for a number of wells, which requires specific management responses. The EIS/EIR should use recent and available well data to develop a comprehensive baseline condition for groundwater levels, and use locally adopted BMOs to determine appropriate thresholds of significance and mitigating responses for dropping groundwater levels.
- The EIS/EIR fails to consider the potential impacts of lowered groundwater levels on the City's urban forest. We request that the document be amended to include such discussion and analysis. The EIS/EIR acknowledges that groundwater levels would drop in response to groundwater pumping necessary to replace surface water transferred south of the Delta. The EIS/EIR does not provide any discussion or analysis of the relationship between the health of the City's urban forest and dropping groundwater levels. The environmental and economic benefits of a healthy urban forest are well known, and include habitat for migrating birds and other wildlife; protection from the extreme impacts of climate change; filtering for rainwater and groundwater; carbon storage, which reduces the amount of harmful greenhouse gases; energy savings from its shade canopy; aesthetic benefits; and enhancement of property values.
- The environmental analysis does not adequately account for projected impacts associated with climate change. Reduced snow pack and sustained droughts are identified as key outcomes of climate change in California. Add to this the significant uncertainty regarding stream/aquifer interaction and the multiple dry years experienced by the State. What affect will this have on sensitive aquifer systems in light of the impacts of climate change?
- The EIS/EIR identifies a number of significant impacts requiring mitigation. Many of the significant impacts rely on *Mitigation Measure GW-1: Monitoring Program and Mitigation Plans* for mitigation. The EIS/EIR directs that monitoring programs and mitigation plans spelled out by this measure be developed consistent with the *2013 Draft Technical Information for Preparing Water Transfers Proposals* and the *2014 Addendum* documents prepared by the Bureau of Reclamation and Department of Water Resources. While the EIS/EIR purports that the

monitoring and mitigation plans required by this measure will mitigate groundwater and biological impacts, the protocols, methodology, and emphasis outlined in the measure focus primarily on reducing effects to third party groundwater users. This critical mitigation measure needs to show a clear nexus for how it will reduce environmental impacts to groundwater and biological resources that will be caused by dropping groundwater levels.

8

Our greatest concern is that water agencies south of the Delta continue to rely upon a transfer-dependent water source that in turn depends on the use of north state groundwater. This proposed long-term water transfer program poses risks which we believe have not been addressed, and would be a precedent for future projects and decisions that could very seriously damage our city's – and our region's – environment, economy, and communities.

9

Thank you for your consideration of these concerns. If you have any questions, please feel free to contact me at (530) 879-6806.

Sincerely,

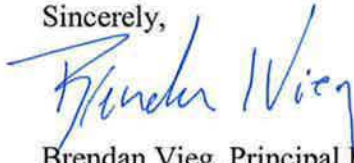

Brendan Vieg, Principal Planner

cc: file

Colusa Drain Mutual Water Company

520 Market Street, Suite 3, Colusa, CA 95932

Phone 530-458-4849

December 1, 2014

Brad Hubbard
Bureau of Reclamation
2800 Cottage Way
Sacramento CA 95825
Email bhubbard@usbr.gov

RE: Long Term Transfers Draft Environmental Impact Statement/Environmental Impact Report

Dear Brad,

The Colusa Drain Mutual Water Company(Company) objects to the EIS/EIR in its current form and requests that the Bureau extend the comment period for at least 120 days to allow the Bureau, the Company, and the Company’s shareholders additional time to consider more carefully the potential negative impacts of the proposed water transfers.

1

Colusa Drain Mutual Water Company includes 50,000 acres of prime farmland and habitat. Shareholder lands lie both sides of the 2047 drain canal west of the Sacramento River and east of Interstate 5. Its northern border reaches into the southern part of Glenn County, it spans from the north to south borders of Colusa County, and its southern boundary lies well into Yolo County in the Yolo Bypass south of Interstate 80. Shareholder lands lie immediately adjacent to, or proximate to, 7 of the potential sellers identified in the EIS/EIR. Most of the Company’s shareholders rely on water from the 2047 drain canal as a primary source of irrigation water and many of the Company’s shareholders rely on groundwater as a secondary source of irrigation water.

2

Our shareholders are particularly concerned that the EIS/EIR has not fully considered the negative impact of the proposed alternatives; Crop Idling, Crop Shifting, and Conservation, on surface flows in the 2047 drain canal. Maintaining a minimum flow of good quality water throughout the length of the 2047 canal during the irrigation season is essential to our shareholder’s farm operations and each of these proposed transfer methods once implemented will most certainly have an immediate negative affect on both water flow and water quality in the 2047. The Company believes that the EIS/EIR does not fully account these negative affects nor does it provide sufficient mitigation alternatives. Since the 2047 drain was first constructed in the early 1900’s, it has served the dual purpose of providing needed drainage for those upstream while providing summer flows for irrigation for those downstream. While difficult at times, this balance between drainage and irrigation has been largely successful for all parties. The company believes the practice of crop idling, crop shifting, and conservation, will result in reduced

surface flows in the 2047 and will increase salinity of the reduced remaining flow. If transfers are to be made, a plan to sufficiently mitigate this negative impact must be proposed. We see no such plan in the EIS/EIR.

2

The Company is also concerned that, while the EIS/EIR appropriately recognizes that the proposed alternative, groundwater substitution, will have 'significant' negative impact on our shareholders groundwater supplies during such transfers, it incorrectly concludes that this impact will be 'less than significant' after mitigation. It is the Company's position that the EIS/EIR provides insufficient mitigation measures in the case of groundwater substitution. And further, that the EIS/EIR does not sufficiently address the damage done to shareholders and our entire community due to long term overdraft of underlying aquifers. In either case, whether in the context of mitigating negative impacts of current groundwater substitution transfers or mitigating negative impacts of long term overdraft of underlying aquifers, the EIS/EIR is inadequate. While groundwater transfers contemplated in the EIS/EIR have not yet taken place, several of the potential sellers identified in the EIS/EIR have already moved ahead with groundwater substitution transfers within Northern California, particularly, to the west side of Colusa, Glenn, and Yolo Counties via the Tehama Canal system. Our Company's shareholders are currently suffering the negative impacts of these groundwater substitution transfers through increased costs of pumping as a result of a lowered aquifers, and in some cases the loss of irrigation water completely, where wells proximate to groundwater substitution wells go dry. Neither the groundwater substitution transfers taking place currently, within Northern California, nor the transfers contemplated by the EIS/EIR, provide a specific plan to limit the taking of groundwater by potential sellers. At a minimum, some responsible limit on the taking of groundwater must be established before surface water can be transferred on the basis of groundwater substitution. To date, no such limits have been set. Our local communities, motivated by heightened awareness as a result of ongoing drought conditions, and as a result of recent state legislation, have begun the process of establishing a system for the responsible management of our community's groundwater. Some communities, like Glenn County, have already made significant progress in this process, while others, Colusa County, for example, have only just begun the process. In no case, however, have sufficient procedures or protections been put in place to adequately provide for responsible execution or reasonable mitigation of groundwater substitution transfers. The Company believes that the alternative 'groundwater substitution' should be dropped entirely from the EIS/EIR as a viable alternative until such time as local communities impacted have completed their own studies and evaluations, developed reasonable plans that include reasonable limits for the taking of groundwater, and these studies, plans, and proposed limits then reconciled with conclusions already reached by the EIS/EIR.

3

The Long Term Transfers contemplated by the EIS/EIR if approved, will be of historic nature. Taken collectively, these transfers would be one of the largest single transfers of water from North to South. So the necessity to fully account the impact on all stakeholders, consider all stakeholders concerns, and thoroughly respond to those concerns cannot be overstated. The Bureau, potential sellers, and

4

Brad Hubbard
December 1, 2014
Page 3

potential buyers, have collaborated over several years to develop the EIS/EIR. Now they must carefully and patiently listen to those that their plan will affect. They must be prepared to explain how the proposed mitigation measures are sufficient to protect the Company's shareholders, and the community in general, from suffering the negative impacts of their plan. Today we are asking you to extend the comment period for at least 120 days to more reasonably allow for this process to take place. We would welcome an opportunity to listen and discuss in more detail the Bureaus plans. I can be reached directly at 530-218-1396(cellular).

4

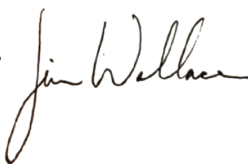
Respectfully, 

Jim Wallace
President, Colusa Drain Mutual Water Company

Cc: Frances Mizuno, Executive Director,
San Luis Delta-Mendota Water Authority

FRIANT

WATER AUTHORITY

LA04

December 1, 2014

Harvey A. Bailey
Chairman of the Board

Nick Canata
Vice Chairman

Tom Runyon
Secretary/Treasurer

Ronald D. Jacobsma
General Manager

Jennifer T. Buckman
General Counsel

Member Agencies

Arvin-Edison W.S.D.
Delano-Earlimart I.D.
Exeter I.D.
City of Fresno
Fresno I.D.
Ivanhoe I.D.
Kaweah Delta W.C.D.
Kern-Tulare W.D.
Lindmore I.D.
Lindsay-Strathmore I.D.
Lower Tule River I.D.
Madera I.D.
Orange Cove I.D.
Pixley I.D.
Porterville I.D.
Saucelito I.D.
Shafter-Wasco I.D.
Stone Corral I.D.
Tea Pot Dome W.D.
Terra Bella I.D.
Tulare I.D.

Main Office

854 N. Harvard Avenue
Lindsay, CA 93247
559.562.6305
559.562.3496 Fax

Sacramento Office

1107 9th Street, Ste. 640
Sacramento, CA 95814
916.346.5165
916.346.4165 Fax

www.friantwater.org

VIA EMAIL TO: bhubbard@usbr.gov

Mr. Brad Hubbard
Bureau of Reclamation
2800 Cottage Way
Sacramento, CA 95825

Re: Draft Environmental Impact Statement/Environmental Impact
Report for Long-Term Water Transfers, Central Valley and Bay
Area, California

Dear Mr. Hubbard,

The Friant Water Authority (FWA) has reviewed the subject Draft EIS/EIR and has the following comments regarding the sufficiency and conclusions of the document. FWA is a joint powers authority whose members have contracts with Reclamation that entitle them to receive water from the San Joaquin River. A portion of the San Joaquin River water is subject to senior water rights reserved by the Exchange Contractors¹ and therefore is not available for delivery to the Friant Division until Reclamation has met its priority obligation² to provide substitute water supply to the Exchange Contractors.

The hydrologic conditions in the 2014 Water Year have highlighted the difficulties inherent in moving both CVP and transfer water through the Delta and the export facilities. In the 2014 Water Year, several districts that are identified in the subject DEIS/R as buyers and sellers executed one-year transfer agreements similar to those described and evaluated in the subject DEIS/R. Reclamation has yet to demonstrate how much transfer water has been moved from the sellers and whether or not the conveyance of that transfer

¹ The remainder of the San Joaquin River rights were purchased, condemned or otherwise acquired by Reclamation for the benefit of the Friant Division contractors. Water available under these rights must be provided to the Friant Division contractors, regardless of whether the terms of the exchange are being fulfilled or not.

² Reclamation has a "vested priority obligation" to provide substitute water to the Exchange Contractors, consistent with the terms of the Second Amended Exchange Contract. *Westlands Water Dist. v. United States*, 337 F.3d 1092, 1103-04 (9th Cir. 2003) ("*Westlands VI*").

water in any way impacted its operations and exports of CVP water needed to meet its priority obligation to the Exchange Contractors.

With this background in mind, we were disappointed to note that the DEIS/R for Long-Term Water Transfers did not address the fact that there is a great potential for the movement of transfer water to adversely affect delivery of CVP supplies south of the Delta. As noted in Section 1.3.1.1, Reclamation acknowledges that it is inappropriate for a transfer to supplant or otherwise adversely affect the delivery of CVP supplies: “Transfer may not cause significant adverse effects on Reclamation’s ability to deliver CVP water to its contractors.” We assume that Reclamation is using the broad definition of the “CVP water” from the Central Valley Project Improvement Act; that definition includes the substitute supply for the Exchange Contractors as a type of “CVP water.” Thus, Reclamation has acknowledged that the delivery of the transfer water may not cause “significant adverse effects” on Reclamation’s ability to deliver the substitute supply of water to the Exchange Contractors, or any other CVP water.

The Project Description in Section 2.3.2.1 describes the criteria used to determine the amounts of water available for transfer under various transfer methods, but it does not describe how such determinations will be made available for public notice or review. Also, Section 2.3.2.3 describes the general operational approaches and actions associated with moving the water from the Seller through the Delta, but it does not describe how or when Reclamation will document that the transferred water did not displace the delivery of substitute water to the Exchange Contractors. Without an adequate description of the procedures and methods to be used to document the development and movement of the transfer water, there is no substantial evidence to support the conclusion that conveying the transfer water has no detrimental effect on the delivery of substitute water to the Exchange Contractors.

Since the Project Description does not include features to ensure no adverse effects on Reclamation’s ability to deliver substitute water to the Exchange Contractors, Chapter 3 should evaluate the potential for such impacts. Before the transfer program is approved, the DEIS/R should be revised to include, at a bare minimum, the following analyses and information:

- Whether the transferred quantity is real “wet” (as opposed to “paper”) water;
- Whether the transfer displaces or otherwise diminishes the ability to deliver CVP water south of Delta;
- What methods will be used to measure the transfer water inputs to the river conveyance system (e.g., foregone diversions or releases from Yuba system), and where will those measurements occur;
- What criteria and methods will be used to determine that transfer water made available by the selling district either made it to the pumps in the south Delta or was backed into storage (including which reservoir(s) the transferred water is being stored at and in what volumes);
- What criteria and methods will be used to determine that releases of transfer water from a CVP reservoir do not constitute water that would have otherwise have been released for in-stream uses; and

1

2

3

- What criteria and methods will be used to determine that water pumped at Jones or Banks pumping plants is in fact transfer water and not water that could have otherwise been pumped due to minimum CVP upstream releases or unregulated flows.

3

Unless this information and these analyses are included in the DEIS/R, it is not possible for the DEIS/R to baldly conclude that the transfer program does not have any potential adverse impacts on the delivery of CVP water supplies.

Thank you for the opportunity to comment on this DEIS/R. If you have any questions regarding these comments, please feel free to contact me at 916-804-0173 or via email to jbuckman@friantwater.org. Please continue to include me, as Friant's representative, on the list of interested parties for purposes of receiving any additional notices relating to the proposed long-term transfer program.

Sincerely,



Jennifer T. Buckman,
General Counsel

cc: Ronald D. Jacobsma, General Manager
Alex M. Peltzer, Esq.
Ernest A. Conant, Esq.
Kenneth J. Richardson, Esq.
Scott K. Kuney, Esq.
D. Zachary Smith, Esq.
John P. Kinsey, Esq.
Robert Saperstein, Esq.



BOARD OF DIRECTORS
Donald R. Bransford, President
Sandy Willard Denn, Vice President
Peter D. Knight
John P. Sutton
Bruce Rolen

GENERAL MANAGER
Thaddeus L. Bettner, P.E.

October 14, 2014

Brad Hubbard
Bureau of Reclamation
2800 Cottage Way, MP-410
Sacramento, CA 95825

Subject: Draft EIS/EIR on Proposed Long-Term Water Transfer Program

Dear Brad,

The Glenn-Colusa Irrigation District (GCID) is providing this initial response letter to Reclamation on the Proposed Long-Term Water Transfer Program Draft EIS/EIR. The purpose of this letter is to inform Reclamation of GCID's intent to develop an independent Groundwater Supplemental Supply Program, as well as provide Reclamation with the District's position on the Long-Term Water Transfer Program. GCID wants to ensure that our local effort and Reclamation's project are not in conflict, and that the project selected to move forward for the Long-Term Program meets GCID's objective to ensure the long term sustainability of surface and groundwater resources in our region. GCID's position is that it will pursue, as a priority, the proposed Groundwater Supplemental Supply Program over any proposed transfer program within the region, including Reclamation's Long-Term Water Transfer Program (LTWTP). In addition, GCID's potential participation in Reclamation's LTWTP is ultimately subject to the consideration and approval of the GCID Board of Directors, and that has not occurred.

Following is a summary of GCID's proposed Groundwater Supplemental Supply Program, and some preliminary comments on LTWTP Draft EIS/EIR.

GCID Groundwater Supplemental Supply Program

GCID is proposing to install and operate five new groundwater production wells and operate an additional five existing groundwater wells to augment surface water diversions for use within GCID during dry and critically dry water years. The wells would have a production well capacity of approximately 2,500 gallons per minute, and would operate as needed during dry and critically dry water years for a cumulative total annual pumping volume not to exceed 28,500 acre-feet. Additional information is available at: <http://gcid.net/GroundwaterProgram.php>.

1

Brad Hubbard
October 14, 2014
Page Two

The primary objective is to develop a reliable supplemental water source for GCID during dry and critically dry years. The proposed project goals are as follows:

- Increase system reliability and flexibility
- Offset reductions in Sacramento River diversions by GCID during drought years to replace supplies for crops and habitat
- Periodically reduce Sacramento River diversions to accommodate fishery and restoration flows
- Protect agricultural production

GCID's surface water supply reliability is becoming less certain as a result of the following:

- Litigation by environmental organizations challenging the renewal of the Sacramento River Settlement Contracts
- Increased delta flow requirements for delta smelt and delta outflows
- Increased flows and temperature requirements for fisheries

USBR Long-Term Water Transfer Program

GCID received the Draft EIS/EIR this week and has only initially begun its review. It is important for Reclamation to understand that GCID has not approved the operation of any District facilities attributed to the LTWTP Action/Project that is presented in the draft EIR/EIS. GCID will be conducting groundwater modeling for the Groundwater Supplemental Supply Program and will include an analysis of any potential cumulative impacts associated with GCID's Project and the LTWTP.

Based on our initial review of Reclamation's LTWTP Draft EIS/EIR, GCID has the following comments:

Figure 3.3-25. Simulated Groundwater Substitution Transfers

This figure demonstrates those years that a groundwater substitution program would likely occur and the associated quantities of groundwater substitution pumping. To meet the needs of GCID's Supplemental Supply Program, it is likely that pumping would occur simultaneously in many of these years. For example, 1992, 1994, and 1997 were critical water years in which GCID received a 75% water supply allocation and in those years the district would have pumped these wells for supplemental supply only. It is important to

Brad Hubbard
 October 14, 2014
 Page Three

underscore that GCID would prioritize pumping during dry and critically dry water years for use in the Groundwater Supplemental Supply Program, and thus wells used under that program would not otherwise be available for the USBR's LTWTP. 2

Table 3.3-3 Water Transfer through Groundwater Substitution

Table 3.3-3 lists 11 GCID wells with associated flow rates between 2,389-3,305 and well depths ranging from 500-1200 feet. GCID would need to thoroughly review this information in greater detail with Reclamation to make sure that well locations, proposed operational parameters, and well characteristics are accurate and which wells, if any, could be included in UBSR'S LTWTP. 3

Figures 3.3-26 thru 3.3-31

The figure does not accurately represent an assessment of cumulative groundwater effects on the groundwater system resulting from other groundwater wells in other districts. As previously mentioned, for the Groundwater Supplemental Supply Program GCID will perform groundwater modeling and will develop new water elevation maps in the vicinity of GCID's project. 4

As mentioned above, these comments are very preliminary as GCID conducts a more in-depth review of the EIR/EIS. If you would like to meet to discuss GCID's program or our initial comments, please contact me at 530-934-8881.

Sincerely,

Thaddeus L. Bettner
 General Manager

Cc: Frances Mizuno, Executive Director,
 San Luis Delta-Mendota Water Authority



BOARD OF DIRECTORS
Donald R. Bransford, President
Sandy Willard Denn, Vice President
Peter D. Knight
John P. Sutton
Bruce Rolan

GENERAL MANAGER
Thaddeus L. Bettner, P.E.

November 18, 2014

Brad Hubbard
Bureau of Reclamation
2800 Cottage Way, MP-410
Sacramento, CA 95825

Subject: GCID Participation in Reclamation's Proposed Long-Term Water Transfer Program

Dear Brad,

As you know, Glenn-Colusa Irrigation District (GCID) sent you a letter on October 14, 2014, providing an initial response to Reclamation on the Proposed Long-Term Water Transfer Program Draft EIS/EIR. The purpose of the letter was to inform Reclamation of GCID's intent to develop an independent Groundwater Supplemental Supply Program, as well as provide to Reclamation the District's position on the Proposed Long-Term Water Transfer Program (LTWTP).

On November 6, 2014, GCID's Board of Directors took the following actions on the LTWTP:

Groundwater Substitution

The LTWTP identifies GCID as pumping 25,000 acre-feet in the years that transfers may occur. Importantly, while the LTWTP covers a ten-year period, transfers would occur only in the critical and/or dry years. Because GCID's surface water supply reliability is being challenged and GCID's surface supplies may be less reliable, GCID will need to implement its Groundwater Supplemental Supply Program in dry and critical years, primarily. Based on Figure 3.3-25 in the LTWTP Draft EIS/EIR, GCID would have pumped in 1992, 1994, and 1997, which were Shasta critical water years during which GCID received a 75% water supply allocation.

Based on the potential conflicts between the needs of GCID landowners and the LTWTP, the GCID Board decided that the District should proceed with its own Groundwater Supplemental Supply Program and should not participate in the Groundwater Substitution component in the LTWTP.

1

Mr. Brad Hubbard
November 18, 2014
Page Two

Land Idling

The LTWTP identifies GCID as idling up to 20,000 acres (providing up to 66,000 acre-feet of transferrable water), which is based on the 20% land idling maximum. The Board evaluated what was in the best interest of GCID, its landowners, and the regional economy and environment. Based on those factors, the Board decided to decrease and limit its participation in the Land Idling component to no more than 10,000 acres (up to 33,000 acre-feet of transferrable water).

2

GCID requests that the LTWTP Draft EIS/EIR be revised to show these changes, and include a corresponding re-evaluation of the potential impacts that will be significantly reduced in Glenn and Colusa Counties as well as neighboring counties.

3

If you would like to meet to discuss GCID's program or our comments, please contact me at 530-934-8881.

Sincerely,



Thaddeus L. Bettner
General Manager

Cc: Frances Mizuno, Executive Director,
San Luis Delta-Mendota Water Authority

200 W. Willmott Avenue
Los Banos, CA 93635-5501



(209) 826-5188
Fax (209) 826-4984
Email: veronica@gwdwater.org

BOARD OF DIRECTORS

Pepper Snyder
President

Doug Federighi
Vice President

Byron Hisey

Tom Mackey

Bob Nardi

Ricardo Ortega
General Manager

Veronica A. Woodruff
Treasurer/Controller

Adams Broadwell Joseph Cardozo PC
General Counsel

December 1, 2014

VIA U.S. MAIL AND E-MAIL

Brad Hubbard
U.S. Bureau of Reclamation
2800 Cottage Way, MP-410
Sacramento, CA 95825
bhubbard@usbr.gov

**Re: Comments on the Long-Term Water Transfers Draft
Environmental Impact Statement**

Dear Mr. Hubbard:

Grassland Water District and Grassland Resource Conservation District (“GWD”) submit the following comments on the Long-Term Water Transfers Draft Environmental Impact Statement/Environmental Impact Report (“EIS”). The EIS will cover individual and multi-year water transfers of up to 500,000 acre-feet per year from north-of-delta water users to south-of-delta water users, from 2015 through 2024 (“Project”). GWD is generally supportive of north-to-south water transfers, as long as potential adverse environmental impacts are avoided or mitigated. The following comments pertain to how the Project will affect Reclamation’s operation of the Central Valley Project (“CVP”) to meet refuge water supply requirements. Section 3406 of the Central Valley Project Improvement Act (“CVPIA”) designates refuge water supplies as “mitigation” for “wildlife losses incurred” as a result of the construction, operation, and maintenance of the CVP. Accordingly, these comments have a direct relationship to the Project’s impacts on

the environment, and each requires a written response under the National Environmental Policy Act.

1. Reclamation should be listed as a potential purchaser of water

First, Grassland Water District is a member agency of the San Luis & Delta Mendota Water Authority (“SLDMWA”), the CEQA lead agency for the Project. As described in the EIS, GWD and other south-of-delta refuges are within the service area of the SLDMWA.¹ GWD requests that the Bureau of Reclamation (“Reclamation”), on behalf of GWD and other south-of-delta refuges, be included in the list of potential purchasers of transferred water under the proposed Project.

GWD is informed that the failure to list refuges as potential Project water recipients may be an inadvertent omission. In the past, when refuges were inadvertently omitted from the list of potential recipients of transferred water, Reclamation has revised the applicable NEPA document.² The EIS should be revised to include the possibility that Reclamation may also purchase water from the listed sellers, on behalf of refuges. Making this change would not require any changes to the EIS analysis. Any impacts associated with the transfer of water from north of the delta to refuges south of the delta would be the same as those analyzed in the EIS, if not lessened by the environmental benefits that would accrue to the receiving refuges.

Reclamation has obligations under the CVPIA and section 3(a) of GWD’s refuge contract to use its “best efforts” to acquire Incremental Level 4 water supplies. By including refuges in the EIS as potential beneficiaries of the Project’s long-term north-to-south water transfer program, Reclamation could better facilitate water purchases for refuges, and would provide an incentive to north-of-delta landowners to offer water for sale to Reclamation’s Refuge Water Supply Program. In fact, Reclamation has purchased refuge water supplies from at least one of the potential listed sellers in the EIS, the Anderson-Cottonwood Irrigation District. This year, Reclamation transferred a portion of that water to a south-of-delta refuge. It makes logical sense to include Reclamation as a potential purchaser of Project water, and to include refuges as potential recipients. To exclude this possibility from coverage under the EIS would be arbitrary and capricious, and would illustrate Reclamation’s disregard for its duty to pursue the acquisition of Incremental Level 4 Water Supplies for refuges—an obligation that Reclamation persistently fails to meet.

¹ EIS p. ES-4.

² *E.g.* Supplemental Environmental Assessment and Finding of No Significant Impact for the South of Delta Accelerated Water Transfer Program (2013), *available at*: http://www.usbr.gov/mp/nepa/nepa_projdetails.cfm?Project_ID=6999.

2. Environmental commitments should benefit CVPIA refuges

Second, Reclamation must consider the implementation of environmental commitments that provide direct benefits to CVPIA refuges, to help offset the impacts of the proposed Project on species such as migratory birds, the giant garter snake, and others. CVPIA refuges will become increasingly important sources of habitat for these species if large volumes of Project water are redirected from habitat-beneficial crops such as rice and corn to non-habitat-beneficial crops and to urban water users. With the likely decrease in available habitat that will result from the proposed Project, and other potential impacts identified in the EIS, CVPIA refuges will bear the brunt of responsibility for meeting the habitat needs that result from operation of the CVP.

Reclamation has proposed no environmental commitments, however, that would benefit CVPIA refuges. Reclamation should offer water sellers a choice between making additional mitigation and restoration payments to the CVPIA Restoration Fund, or directly selling a percentage of the proposed water to be transferred to the Refuge Water Supply Program. *If only 5 to 10 percent of the proposed water to be transferred were sold to the Refuge Water Supply Program, the persistent deficit in Level 4 refuge water deliveries would be significantly cured.*

3. No adverse impacts on refuge water deliveries may occur

Third, Reclamation must assure refuge contractors that the potential transfer of 500,000 acre-feet of water annually would have no adverse effect on the timing or volume of refuge water deliveries, or the future capability of the CVP to deliver full Level 4 refuge water supplies. CVPIA section 3405(a)(1)(H), and other provisions of Reclamation Law such as the Warren Act, prohibit Reclamation from approving water transfers if they would have any adverse effect on Reclamation's ability to deliver water to meet its contractual or fish and wildlife obligations "because of limitations in conveyance or pumping capacity." This prohibition must not be ignored.

The EIS does not describe the order of priority for use of CVP facilities, other than a statement that transferred water can only be conveyed "after Project needs are met."³ GWD is increasingly concerned that Reclamation has prioritized the conveyance of water transfers over the delivery of water that refuges are contractually and legally entitled to receive. GWD suffered a 10% reduction in its contractual entitlement to receive firm Level 2 water supplies this year. Despite GWD's repeated requests for an explanation of this deficiency, GWD was instead left with the impression that full Level 2 deliveries this fall and winter may have been denied so as to avoid interference with proposed water transfers. This is

³ EIS, p. 2-18.

unacceptable. Reclamation must provide a written response to this comment to confirm that all refuge water deliveries, including the full potential capacity for Level 4 water deliveries, will take priority over the conveyance of transferred water supplies.

3

4. Clarifications and assurances are needed for water transfers by Merced Irrigation District

The EIS contemplates that water may be transferred by Merced Irrigation District (“MID”) through a variety of potential conveyance mechanisms. MID has a binding commitment, however, under its Federal Energy Regulatory Commission license, to provide 15,000 acre-feet of water directly to the Merced National Wildlife Refuge. Most of this water (13,500 acre-feet) is credited toward Reclamation’s Level 2 water supply obligation to the Merced refuge, and the remainder is credited toward Reclamation’s Incremental Level 4 obligation.⁴ Reclamation cannot authorize transfers by MID to others unless and until MID’s water delivery obligation to Merced National Wildlife Refuge is first met. To act otherwise would violate Reclamation’s duties under the CVPIA and under Reclamation’s water supply contract with the U.S. Fish and Wildlife Service. Reclamation should revise its EIS or provide a written response to this comment to confirm that water will not be authorized for transfer by MID in any year that MID fails to meet its obligation to provide 15,000 acre-feet of water to the Merced National Wildlife Refuge.

4

Moreover, the EIS describes a mechanism whereby MID would exchange water to others by delivering water to “refuges in the San Luis unit” that would in turn reduce their water use “from the Delta-Mendota Canal.”⁵ The EIS must note that under the terms of Reclamation’s refuge water contracts, exchanges involving refuge water supplies must be agreed to by the refuge contractor. Furthermore, the proposed refuge exchange mechanism is not adequately described. There are only two refuges that can directly receive water from MID’s conveyance system, Merced National Wildlife Refuge and the East Bear Creek Unit of the San Luis National Wildlife Refuge. These refuges are located east of the San Joaquin River, and they do not use water from the Delta-Mendota Canal. The EIS does not sufficiently explain how this proposed exchange mechanism would work.

Thank you for considering and responding to these comments, and please feel free to contact me to discuss any of these issues further.

⁴ See Exhibit “B” to Reclamation’s contract with the United States Fish and Wildlife Service, available at: http://www.usbr.gov/mp/cvpia/3406d/env_docs/final/1758_exh_b_fws.pdf

⁵ EIS, p. 2-25.

Sincerely,

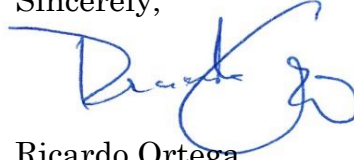
A handwritten signature in blue ink, appearing to read 'Ricardo Ortega', with a stylized flourish at the end.

Ricardo Ortega
General Manager

cc: Frances Mizuno (via e-mail, frances.mizuno@sldmwa.org)
Pablo Arroyave (via e-mail, parroyave@usbr.gov)
Jason Phillips (via e-mail, jphillips@usbr.gov)
Federico Barajas (fbarajas@usbr.gov)
Richard Woodley (via e-mail, rwoodley@usbr.gov)
Dan Nelson (dan.nelson@sldmwa.org)

LOCAL AGENCIES OF THE NORTH DELTA

1010 F Street, Suite 100, Sacramento, CA 95814
(916) 455-7300, osha@semlawyers.com

December 1, 2014

SENT VIA EMAIL (bhubbard@usbr.gov)

Brad Hubbard
Bureau of Reclamation
2800 Cottage Way, MP-410
Sacramento, CA 95825

**RE: Comments on Long-Term Water Transfers EIS/R
State Clearinghouse No. 2011011010**

Dear Mr. Hubbard:

These comments on the Long-Term Water Transfers Environmental Impact Statement/Environmental Impact Report (“EIS/R”) (“project”) are submitted on behalf of the Local Agencies of the North Delta (“LAND”). LAND is a coalition comprised of reclamation and water districts in the northern geographic area of the Delta.¹ As local agencies in the Delta, LAND is concerned about any actions that would result in water supply and/or quality impacts in the Delta that may occur as a result of the project. This letter addresses the following inadequacies of the EIS/R: (1) use of the wrong lead agency under the California Environmental Quality Act (Pub. Resources Code, §§ 21000 et seq. (“CEQA”)); (2) failure to consider the cumulative effects of the project in combination with the Bay Delta Conservation Plan (“BDCP”); and (3) inadequacy of mitigation for significant effects caused by implementation of the project.

1

San Luis & Delta-Mendota Water Authority is the Wrong Lead Agency

Under CEQA, the “lead agency” is “the public agency which has the principal responsibility for carrying out or approving a project” (Pub. Resources Code, § 21067.) Where several agencies have a role in approving, implementing or realizing a project, CEQA “plainly requires the public agency with principal responsibility to assume the role as lead agency.” (*Planning & Conservation League v. Department of Water*

2

¹ LAND member agencies cover an approximately 110,000 acre area of the Delta; current LAND participants include Reclamation Districts 3, 150, 307, 317, 349, 407, 501, 551, 554, 556, 744, 755, 813, 999, 1002, 2111, 2067 and the Brannan-Andrus Levee Maintenance District. Some of these agencies provide both water delivery and drainage services, while others only provide drainage services. These districts also assist in the maintenance of the levees that provide flood protection to homes and farms.

Mr. Brad Hubbard
December 1, 2014
Page 2 of 4

Resources (2000) 83 Cal.App.4th 892, 906.) According to the Third District Court of Appeal, “the lead agency plays a pivotal role in defining the scope of environmental review, lending its expertise in areas within its particular domain, and in ultimately recommending the most environmentally sound alternative.” (*Id.* at 904.) “So significant is the role of the lead agency that CEQA proscribes delegation.” (*Id.* at 907.)

According to the EIS/R, the San Luis & Delta-Mendota Water Authority (“SLDMWA”), “consisting of federal and exchange water service contractors in western San Joaquin Valley, San Benito, and Santa Clara counties, helps *negotiate* transfers in years when the member agencies could experience shortages.” (EIS/R, p. 1-1, italics added.) Furthermore: “This EIS/EIR addresses water transfers to [Central Valley Project (“CVP”)] contractors from CVP and non CVP sources of supply that must be conveyed through the Delta using both CVP, SWP, and local facilities. These transfers require approval from Reclamation and/or *the Department of Water Resources (DWR)*, which necessitates compliance with NEPA and CEQA.” (EIS/R, p. ES-1, italics added.)

SLDMWA is not the proper CEQA lead agency for the project. Here, it appears that DWR has the principle responsibility with respect to carrying out and approving water transfers and would be the proper lead agency. Much like the lead agency role struck down in the *Planning and Conservation League* case, SLDMWA’s assistance in negotiating transfers is insufficient to give rise to a lead agency role under CEQA. (See 83 Cal.App.4th at p. 906.) As a result of this error, the entire EIS/R process is tainted and must be restarted with the correct lead agency.

BDCP as a Cumulative Project

When conducting a cumulative impact analysis, a lead agency has the choice of using either the list-of-projects approach or the summary-of-projections approach, depending on which method is best suited to a particular situation. (CEQA Guidelines, § 15130, subd. (b)(1).) According to the EIS/R, “both methods” are used. (EIS/R, p. 4-3.) Yet the EIS/R fails to consider the effects of the project combined with the implementation of the BDCP. The BDCP is currently undergoing public review (Bureau of Reclamation is also the NEPA lead agency), and could be approved and implemented within the timeframe of the project. (See <http://baydeltaconservationplan.com/PlanningProcess/EnvironmentalReview/TheProcess.aspx>.)

The BDCP consists of new diversion facilities on the Sacramento River as well as other actions that constitute a proposed Habitat Conservation Plan within the Sacramento-San Joaquin Delta. While the diversion facilities would not be constructed within the 10 year timeframe of the project, other so-called conservation measures could

2

3

Mr. Brad Hubbard
December 1, 2014
Page 3 of 4

be implemented. The cumulative effects of those aspects of the BDCP that could be implemented within the timeframe of the proposed project must be analyzed.

In particular, cumulative effects from reductions in Delta outflow should be analyzed. According to the EIS/R, the project would lead to changes in Delta hydrology. (EIS/R, p. 3.8-62.) These changes should be considered in conjunction with the BDCP, which may reduce Delta outflow by dramatically increasing the amount of open water habitat in the Delta (up to 65,000 acres tidal marsh). According to DWR data, open water and riparian vegetation consume about 67.5 acre-feet per year, which is much greater than most agricultural uses. (See Exhibit A.)² The project's potential, in combination with BDCP, to reduce Delta outflow must be considered.

3

The cumulative effects of weed growth that results from BDCP/habitat projects in the Delta and within the Seller service areas on fallowed lands should also be considered. The EIS/R apparently assumes that invasive weeds will be managed on fallowed lands in the Seller area. Invasive weeds, however, consume significant quantities of water and may result in less water being available for transfer than assumed in the EIS/R. According to a 2004 study, for instance, about "one million acre-feet of water is consumed by star thistle each year in the Central Valley above and beyond what would be consumed by annual grasses."³ In addition to analyzing water demand of weeds in the Delta under BDCP as well as in the Seller service areas, effective weed management should be included as a mitigation measure.

Inadequacy of Mitigation Measures

The EIS/R contains inadequate mitigation for the significant effects of the project. In particular, Mitigation Measure GW-1 ("GW-1") does not meet basic CEQA requirements for mitigation. (Cf. CEQA Guidelines, § 15126.4; *Communities for a Better Environment v. City of Richmond* (2010) 184 Cal.App.4th 70, 94-95 (describing requirements for use of specific performance criteria to ensure the efficacy of the mitigation).) While the EIS/R states that this mitigation measure would reduce impacts related to natural communities in rivers and creeks in the Sacramento River Watershed, for instance (EIS/R, p. 3.8-51), this mitigation measure monitors wells, not river and creek levels. The analysis also assumes without any support that natural recharge will

4

² Department of Water Resources, Bulletin 168 (October 1978) titled, "Sacramento Valley Water Use Survey 1977," Table A-5 (showing 1976-77 Estimated Crop Evapotranspiration Values for the Delta Service Area).

³ Cal-IPC News, Newsletter of the California Invasive Plant Council (Summer 2014), p. 11, available at: http://origin.library.constantcontact.com/download/get/file/1101215423203-171/Cal-IPC_News_Summer2014.pdf.

Mr. Brad Hubbard
December 1, 2014
Page 4 of 4

correct any environmental impacts that do occur. GW-1 also leaves entirely open the amount of time an adverse impact could occur and before it will be corrected. This approach fails to meet the requirement to mitigate the project's impacts to the extent feasible, as required by CEQA. (See Pub. Resources Code, § 21002.) While CEQA permits deferral of formulation of mitigation in certain instances, minimum requirements for deferred mitigation are not met by GW-1.

4

CONCLUSION

Overall, we remain concerned that the project, in combination with other cumulative projects, will significantly affect Delta water supply and quality for in-Delta users. While increased transfers have the potential to increase flows into the Delta, it is not clear that this project will result in such flow increases. Without actual increases in flows, this transfer program could facilitate increased diversions out of the Delta for CVP contractors, leaving in Delta water supplies further depleted and degraded. We respectfully request that the EIS/R be corrected and recirculated to correct the deficiencies identified in these and other comment letters prior to any action being taken on the project. Thank you for considering these comments.

5

Very truly yours,

SOLURI MESERVE
A Law Corporation

By:



Osha R. Meserve

Enclosure: Exhibit A - DWR Bulletin 168 (October 1978), Table A-5

EXHIBIT A

TABLE A-5
1976-77 Estimated Crop Et Values
Delta Service Area
(in inches)

Land Use Category	Oct.	Nov.	Dec.	Jan.	Feb.	Mar.	Apr.	May	June	July	Aug.	Sep.	Total : Oct.76-Sep.77	Oct. 77	Total :Nov.77-Oct.77
Sacramento-San Joaquin Delta															
Irrigated Pasture	3.2	1.5	1.0	0.7	1.5	3.6	5.4	4.8	6.9	7.7	6.4	4.7	47.4	3.4	47.6
Alfalfa	3.2	1.5	1.0	0.7	1.5	3.2	4.9	4.4	6.5	7.5	6.5	4.9	45.8	3.4	46.0
Deciduous Orchard (Fruits & Nuts)	2.6	1.5	1.0	0.7	1.5	2.7	3.8	4.0	6.1	7.4	6.1	4.3	41.7	2.6	41.7
Tomatoes	2.4	1.5	1.0	0.7	1.5	1.9	2.2	2.6	4.0	8.2	6.0	2.3	34.3	1.9	33.8
Sugar Beets	2.4	1.5	1.0	0.7	1.5	1.9	2.2	3.7	7.6	8.3	6.4	4.4	41.6	2.4	41.6
Grain Sorghum (Milo)	2.4	1.5	1.0	0.7	1.5	1.9	2.2	2.0	5.9	7.3	4.3	2.5	33.2	1.9	32.7
Field Corn	2.4	1.5	1.0	0.7	1.5	1.9	2.2	2.3	5.7	6.9	5.1	2.6	33.8	1.9	33.3
Dry Beans	2.4	1.5	1.0	0.7	1.5	1.9	2.2	1.7	5.7	6.2	2.7	2.5	30.0	1.9	29.5
Safflower	2.4	1.5	1.0	0.7	1.5	1.9	2.5	4.8	8.7	7.7	4.4	2.5	39.6	1.9	39.1
Asparagus	2.4	1.5	1.0	0.7	1.5	1.9	2.2	1.0	3.5	7.7	6.4	4.7	34.5	2.4	34.5
Potatoes	2.4	1.5	1.0	0.7	1.5	1.9	2.2	1.7	4.3	7.4	5.5	2.8	32.9	1.9	32.4
Irrigated Grain	2.4	1.5	1.0	0.7	2.0	4.3	5.7	3.1	1.8	1.0	1.0	1.6	26.1	1.6	24.7
Vineyard	2.4	1.5	1.0	0.7	1.5	1.9	2.2	2.8	5.3	6.5	5.3	3.4	34.5	2.4	34.5
Rice	3.2	1.5	1.0	0.7	1.5	1.9	2.8	5.6	8.8	9.8	8.1	5.5	50.4	3.4	50.6
Sudan	2.4	1.5	1.0	0.7	2.0	4.3	5.7	4.8	6.9	7.7	4.9	4.7	46.6	2.4	46.6
Misc. Truck	2.4	1.5	1.0	0.7	1.5	1.9	3.2	4.6	6.7	7.4	5.2	3.7	39.8	1.9	39.3
Misc. Field	2.4	1.5	1.0	0.7	1.5	1.9	2.2	2.4	6.1	7.4	5.0	1.9	34.0	1.9	33.5
Double Cropped with Grain															
Sugar Beets	2.4	1.5	1.0	0.7	2.0	4.3	5.7	3.1	1.8	4.2	5.2	5.8	37.7	3.4	38.7
Field Corn	2.4	1.5	1.0	0.7	2.0	4.3	5.7	3.1	1.8	4.3	6.3	6.1	39.2	2.7	39.5
Grain Sorghum (Milo)	2.4	1.5	1.0	0.7	2.0	4.3	5.7	3.1	1.8	2.7	6.1	5.2	36.5	1.9	36.0
Sudan	2.4	1.5	1.0	0.7	2.0	4.3	5.7	3.1	3.6	7.7	4.9	4.7	41.6	1.9	41.1
Dry Beans	2.4	1.5	1.0	0.7	2.0	4.3	5.7	3.1	3.1	7.6	3.5	1.5	36.4	1.9	35.9
Tomatoes	2.4	1.5	1.0	0.7	2.0	4.3	5.7	3.1	2.3	6.6	6.0	5.2	40.8	1.9	40.3
Lettuce	2.4	1.5	1.0	0.7	2.0	4.3	5.7	3.1	4.1	7.4	5.3	4.9	42.4	2.4	42.4
Misc. Truck	2.4	1.5	1.0	0.7	2.0	4.3	5.7	3.1	2.3	6.6	6.0	5.2	40.8	2.4	40.8
Misc. Field	2.4	1.5	1.0	0.7	2.0	4.3	5.7	3.1	4.1	7.4	5.3	4.9	42.4	3.4	43.4
Fallow Lands 1/	2.4	1.5	1.0	0.7	1.4	1.0	1.0	1.0	1.0	1.0	1.0	1.0	14.0	1.0	12.6
Native Vegetation 2/	2.4	1.5	1.0	0.7	1.4	3.7	3.8	2.1	2.3	2.6	2.3	2.0	25.8	1.6	25.0
Riparian Veg. & Water Surface	4.6	2.4	1.4	0.8	1.9	4.5	7.4	6.6	9.7	11.8	9.7	7.0	67.8	4.3	67.5
Urban	1.6	0.8	0.6	0.7	1.0	1.0	1.9	2.4	2.4	2.5	2.4	1.9	19.2	1.6	19.2

1/ Applies also to nonirrigated grain.

2/ Applies also to nonirrigated orchards and vineyards

Metric conversion: inches times 25.4 equals millimetres.



RECLAMATION
DISTRICT

108

975 Wilson Bend Road
P.O. Box 50
Grimes, CA 95950-0050
(530)437-2221
Fax: (530)437-2248
www.rd108.org

Board of Trustees
Frederick J. Durst, President
Michael Miller, Vice President
Roger Cornwell
Sean Doherty
Jon Leonard

General Manager
and Secretary
Lewis Bair

Assistant Manger
Bryan Busch

December 1, 2014

Via e-mail (bhubbard@usbr.gov)
Brad Hubbard
United States Bureau of Reclamation
2800 Cottage Way, MP-410
Sacramento, CA 95825

Via e-mail (frances.mizuno@sldmwa.org)
Frances Mizuno
San Luis and Delta-Mendota Water Authority
P.O. Box 2157
Los Banos, CA 93635

Re: Comments on Draft EIS/EIR on Proposed Long-Term Water Transfers

Dear Mr. Hubbard and Ms. Mizuno:

Reclamation District 108 (“RD 108”) respectfully submits these comments on the September 2014 Draft Environmental Impact Report/Environmental Impact Statement (“EIS/EIR”) for the above-referenced project.

RD 108 has no concerns with a reasonable groundwater substitution program. Indeed, RD 108 is identified as a potential transferor of groundwater substitution water in the EIS/EIR and may be willing to transfer up to 15,000 acre-feet per year of surface water made available through groundwater substitution. (Draft EIS/EIR, at Table 2-5.)

RD 108 is concerned, however, about the intensity and magnitude of the proposed Conaway Preservation Group (“Conaway”) groundwater substitution program. RD 108 covers nearly 48,000 acres and will potentially substitute up to 15,000 acre-feet/year of groundwater to replace transferred surface water. RD 108 will thus pump less than 1/3 of an acre-foot per acre of land per year. On the other hand, Conaway owns 16,088 acres of land, but will pump up to 35,000 acre-feet/year under the proposed project. Thus, Conaway’s proposed groundwater substitution program, as described in the EIS/EIR, will result in pumping of more than 2 acre-feet of groundwater per acre of land owned by Conaway.

Conaway, however, has an even more ambitious groundwater substitution program than the EIS/EIR indicates. Through an agreement with the Woodland-Davis Clean Water Agency (“WDCWA”), Conaway may pump up to an additional 10,000 acre-feet/year to substitute for a transfer of surface water rights to WDCWA. Accordingly, if Conaway pumps the maximum amount of groundwater for which authorization is being sought under the long-term transfer program and the WDCWA Water Agreement, Conaway could pump a maximum annual quantity of 45,000 acre-feet of groundwater. This would result in Conaway pumping nearly 3 acre-feet per acre of land.

1

2

While RD 108 has no objection to the provision of water to WDCWA through groundwater substitution, the cumulative impacts of Conaway's groundwater pumping for WDCWA and its groundwater pumping for the long-term transfer program must be fully analyzed as required by the National Environmental Policy Act and the California Environmental Quality Act.

2

RD 108 COMMENTS ON EIS/EIR

1. **Impacts Analysis:** The EIS/EIR's analysis of the environmental impacts of the proposed groundwater substitution program is deficient in at least three respects:

- a. The EIS/EIR only includes an analysis of impacts related to groundwater pumping for Conaway's proposed 35,000 acre-feet/year groundwater substitution program. Because Conaway intends to pump an additional 10,000 acre-feet/year pursuant to its agreement with WDCWA, the impacts analysis on groundwater levels and land subsidence are artificially deflated.
- b. Measuring groundwater level drawdown at only one location on Conaway Ranch is inadequate given the magnitude of Conaway's proposed groundwater substitutions. (Draft EIS/EIR, at Figure 3.3-26.) As the EIS/EIR indicates, land subsidence has occurred at Conaway Ranch in the past. (Draft EIS/EIR, at 3.3-82.) Accordingly, the EIS/EIR should have analyzed more fully the land subsidence and groundwater level drawdown impacts in Conaway's area. Instead, the EIS/EIR analyzes impacts on groundwater levels and subsidence in three locations far from Conaway, while relegating a hydrograph of the Conaway location (Location 30) to the Appendix with little analysis. (Draft EIS/EIR, at E-204-E210.) Moreover, as Exhibit 1 to this letter demonstrates, the effects of Conaway's groundwater pumping are already causing land subsidence. But instead of measuring conditions that have already occurred, the draft EIS/EIR relies on a simulation of Conaway's proposed pumping that does not take its current actions into account. Therefore, the final EIS/EIR should evaluate potential environmental impacts based on current conditions, rather than on a simulation in which the data set ends in Water Year 2003.
- c. Impacts from subsidence related to the Project and Project Alternatives are not presented in the EIS/EIR. This is a particularly important issue in relation to Conaway because Conaway has flood control levees adjacent to its property. One would expect that the increase in the magnitude of subsidence currently experienced at Conaway Ranch from existing pumping (which is not quantified or described in the draft EIS/EIR) would increase in relation to the expected groundwater level declines from the Project. Subsidence is often a delayed response to groundwater level declines and the proposed monitoring for subsidence is inadequate to assess longer term or delayed effects from subsidence that could occur after pumping for groundwater substitution has ceased.

3

2. **Mitigation Measures:** The draft EIS/EIR fails to adequately develop and explain how the potentially significant impacts of the project will be mitigated. Mitigation Measure GW-1 is insufficiently robust to reduce impacts from the proposed project to less than significant. In particular, the mitigation measures for land subsidence are inadequate. The mitigation measures proposed in GW-1 for land subsidence are not sufficiently set forth in the EIS/EIR. (See Draft EIS/EIR, at section 3.3.4.1.) Instead, GW-1 defers to a monitoring program to be developed in the future by the U.S. Bureau of Reclamation. Furthermore, the EIS/EIR states that areas with "higher susceptibility to land subsidence will also require more extensive monitoring" without specifying what that more extensive monitoring will involve. Mitigation Measure GW-1 also does not include any provisions for well replacement should well interference or longer term groundwater level declines result in

4

wells going dry and an inability for bowls or pumps to be lowered in response to Project impacts. Most importantly, the bulk of the mitigation responsibility falls on sellers, but the individual sellers' plans are nowhere to be found in the EIS/EIR. In short, the EIS/EIR claims that mitigation measure GW-1 mitigates the potentially significant land subsidence effects without describing what the mitigation program actually entails. The final EIS/EIR should develop and analyze each of these aspects of the mitigation measure in greater detail.

4

3. Cumulative Impacts Analysis: The cumulative impacts analysis is inadequate in that it does not include an analysis of the WDCWA project. Moreover, the cumulative impacts of other reasonably foreseeable groundwater development projects must be analyzed in the EIS/EIR.

5

Thank you for the opportunity to submit these comments.

Sincerely,



Lewis Bair
General Manager

Enclosure

AQUA-266C

California Department of Water Resources

HYPLOT V133 Output 11/14/2014

Period 23 Year Plot Start 00:00_01/01/1992

1992-2015

Interval 15 Day Plot End 00:00_01/01/2015

— 09N03E08C004M CON Ext and P4 deep 115.00 Mean GS Displacement (ft)

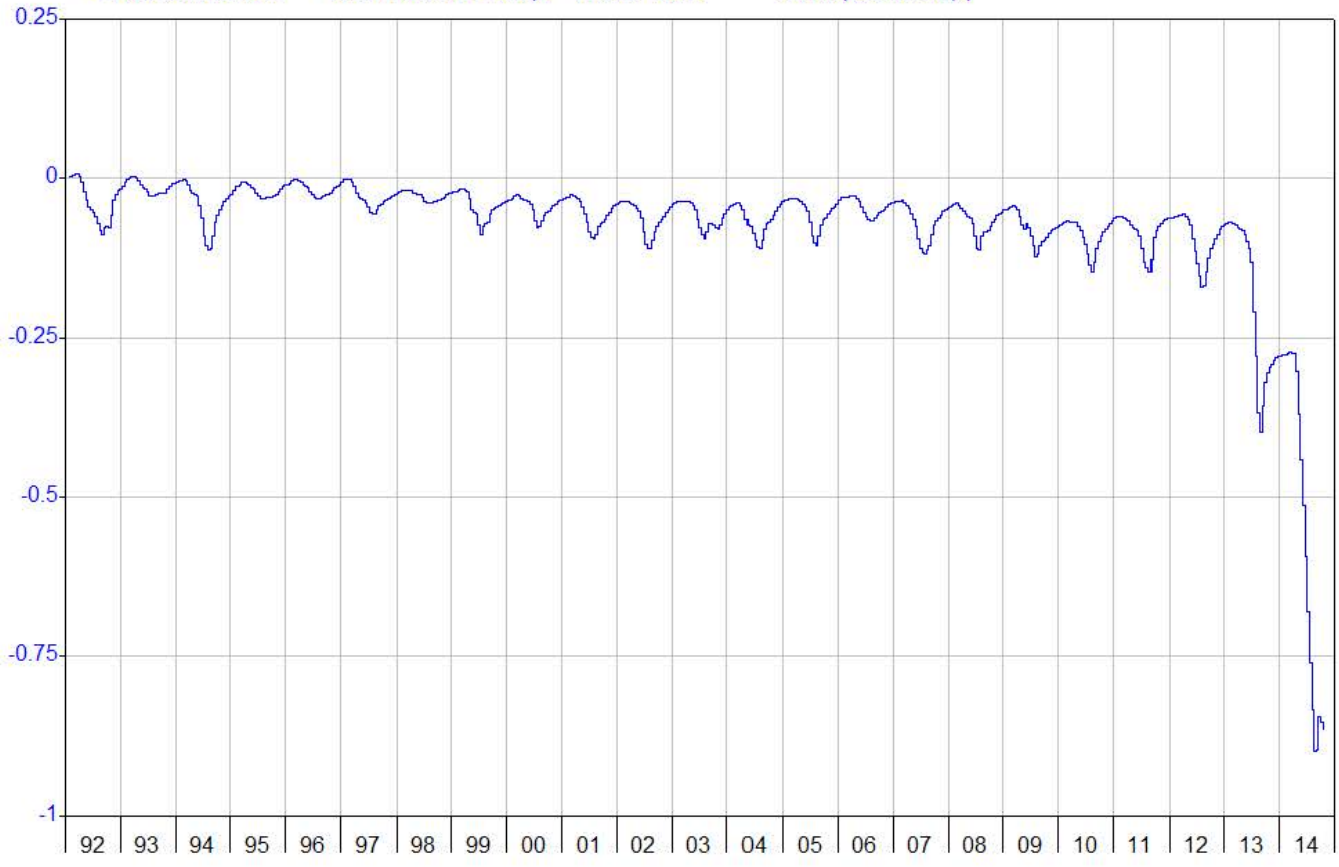

November 25, 2014

SENT VIA EMAIL ONLY

Mr. Brad Hubbard
Bureau of Reclamation
2800 Cottage Way
Sacramento, CA 95825

Long-Term Water Transfers Draft Environmental Impact Statement/Environmental Impact Report (SAC201401523)

Dear Mr. Hubbard:

The Sacramento Metropolitan Air Quality Management District (SMAQMD) staff reviewed the Long-Term Water Transfers Draft Environmental Impact Statement/Environmental Impact Report (EIS/EIR). SMAQMD staff provides the following comment regarding the air quality section.

The EIS/EIR provides two measures to reduce air emissions from the project:

- AQ-1: Reduce pumping at diesel or natural gas wells to reduce pumping below significance levels, and
- AQ-2: Operate dual-fired wells as electric engines.

State CEQA Guidelines require mitigation measures to be fully enforceable through permit conditions, agreements, or other legally binding instruments (§15126.4(a)(2)). Additional details on how AQ-1 and AQ-2 will be implemented and enforced are necessary to ensure the emissions from the project will not have a significant impact to air quality.

Please contact me at 916-874-4881 or khuss@airquality.org if you have any questions. I look forward to receiving a notice when the final EIS/EIR is released.

Sincerely,

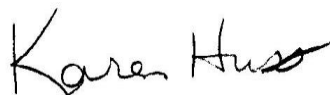

Karen Huss
Associate Air Quality Planner/Analyst

Cc: Larry Robinson, SMAQMD
Carter Jessop, USEPA Region 9

December 1, 2014

Mr. Brad Hubbard, Project Manager
Bureau of Reclamation
2800 Cottage Way
Sacramento, CA 95825

Ms. Frances Mizuno, Assistant Executive Director
San Luis & Delta-Mendota Water Authority
P.O. Box 2157
Los Banos, CA 93635

Subject: Santa Clara Valley Water District's Comments on Draft Environmental Impact Statement/Environmental Impact Report for Long-Term Water Transfers

Dear Mr. Hubbard and Ms. Mizuno:

Thank you for the opportunity to review and comment on the Draft Environmental Impact Statement/Environmental Impact Report (EIS/EIR) prepared by the Bureau of Reclamation (Reclamation) and the San Luis & Delta-Mendota Water Authority (SLDMWA) for the proposed Long-Term Water Transfers Project (Project). The Santa Clara Valley Water District (SCVWD) understands that Reclamation is serving as the lead agency under the National Environmental Policy Act (NEPA) and that SLDMWA is serving as the lead agency under the California Environmental Quality Act (CEQA). These comments are provided by SCVWD for both NEPA and CEQA.

SCVWD respectfully requests that Reclamation and SLDMWA provide further discussion regarding the items identified below in order to more fully comply with NEPA, CEQA, and those laws' respective public disclosure and analysis requirements. SCVWD's comments relate primarily to the analysis of the Project's potential impacts to the San Felipe Division related to San Luis Reservoir (SLR).

Information provided in Section 3.2.2.4.2 (pp. 3.2-41 and 3.2-42) indicates that the projected SLR storage levels are lower under the Proposed Action. The Draft EIS/EIR recognizes that SLR storage "could decrease by as much as six percent (of water in storage in the No Action/No Project Alternative) during August of critical water years." Based on Table 3.2-27 on p. 3.2-42, monthly storage in SLR during a critical year could decrease by as much as 27,300 acre-feet (AF) between June and October, when SLR typically has the highest likelihood of reaching its lowest storage levels. The Draft EIS/EIR concludes that "potential storage-related effects on water quality would be less than significant for San Luis Reservoir." SCVWD would like more information to substantiate the statement that "these small changes in storage are not sufficient to ... substantially degrade water quality." SCVWD would also like more information on whether deliveries to Santa Clara County could be impaired with the Project.

SCVWD relies on delivery of its Central Valley Project (CVP) water and other imported water supplies from SLR through the San Felipe Division. When SLR storage levels drop below an elevation of 369 feet, about 300,000 AF in storage or the "low point", algal blooms occurring during the summer can enter the lower intake of the Pacheco Pumping Plant and deliveries of

1



Mr. Brad Hubbard and Ms. Frances Mizuno
Page 2
December 1, 2014

SCVWD's CVP supplies can be adversely affected; water quality within the algal blooms is not suitable for municipal and industrial water users relying on existing water treatment facilities in Santa Clara County. Deliveries to the San Felipe Division may be severely or completely interrupted when storage levels are drawn down such that there is insufficient hydraulic head to effectively operate Pacheco Pumping Plant. The EIS/EIR should provide more detail on the existing low point issue, and existing Reclamation operational protocols designed to minimize low point conditions. It should also provide greater analysis and detail on the impacts of the Project on SLR storage levels, and on SCVWD's water supplies due to low point conditions.

1

SCVWD thanks Reclamation and the SLDMWA for the opportunity to review and comment on the Draft EIS/EIR. SCVWD appreciates the Project's overall goal of increasing flexibility and reliability with regard to management of CVP water supplies. However, SCVWD requests that Reclamation and SLDMWA expand on the issues identified above in order to comply with CEQA and NEPA. SCVWD believes it is necessary to provide a more complete environmental analysis under NEPA and CEQA to help ensure that the Project does not provide a benefit to certain water providers to the potential detriment of others.

If you have any questions, please contact Cindy Kao at (408) 630-2346 or ckao@valleywater.org.

Sincerely,



Garth Hall
Deputy Operating Officer
Water Supply Division

SOUTH DELTA WATER AGENCY

4255 PACIFIC AVENUE, SUITE 2
STOCKTON, CALIFORNIA 95207
TELEPHONE (209) 956-0150
FAX (209) 956-0154
E-MAIL Jherrlaw@aol.com

Directors:

Jerry Robinson, Chairman
Robert K. Ferguson, Vice-Chairman
Natalino Bacchetti
Jack Alvarez
Mary Hildebrand

Counsel & Manager:
John Herrick

December 1, 2014

bhubbard@usbr.gov

Mr. Brad Hubbard
Bureau of Reclamation
2800 Cottage Way
Sacramento, CA 95825

Re: Draft Environmental Impact Statement/Environmental Impact Report for Long-Term Water Transfers, Central Valley and Bay Area, California

Dear Mr. Hubbard:

The following comments and the attached comments are submitted on behalf of the South Delta Water Agency and the Central Delta Water Agency. Each of these agencies are charged with, and the surrounding lands dependent on good quality water in Delta channels for the protection of agricultural and other beneficial uses. Operations of the Central Valley Project and the State Water Project adversely affect flows, circulation, levels, and quality of water in the channels to the detriment of agricultural and other beneficial water users. By statute, regulation and permit, the United States Bureau of Reclamation ("USBR") and the Department of Water Resources ("DWR") are supposed to fully mitigate their impacts on such other uses as well as maintain various water quality standards intended to protect the Delta estuary and in-Delta users. The projects fail to meet these obligations on a regular basis and the proposed Long Term Transfer Project ("Project") may exacerbate DWR and USBR's continued failure to meet their obligations. SDWA and CDWA represent various water right holders who may be affected by the Project.

1. The Project in significant part appears to violate the language and spirit of CVPIA, the controlling federal statute for CVP-related water transfers.

In 1992, Congress passed and the President signed into law the Central Valley Project Improvement Act, commonly known as "CVPIA" or Public Law 102-575. The provisions of CVPIA fundamentally altered the operation of the CVP, requiring a dedication of water for fish and wildlife purposes, significant habitat and fish population goals and mandates and set forth new criteria for water transfers. CVPIA defined "Central Valley Project water" as "all water that is developed, diverted stored, or delivered by the Secretary in accordance with the statutes authorizing the Central Valley Project and in accordance with the terms and conditions of water rights acquired pursuant to California law." This broad description of CVP water importantly uses the word "or" to include virtually any water that gets from one place to another via the CVP, notwithstanding any water right under which the water might originally derive.

Mr. Brad Hubbard
 December 1, 2014
 Page - 2 -

CVPIA also specifies the terms and conditions under which transfers of CVP water can be made. Section 3405 of the Act allows transfers of any CVP water “under water service or repayment contracts, water rights settlement contracts or exchange contracts. . . .” Thus, any individual or district which receives CVP water can transfer its CVP water if they or it comply with Section 3405.

Section 3405 (a)(1)(I) limits the transfers “to water that would have been consumptively used or irretrievably lost to beneficial use during the year of years of the transfer.” The purpose of this provision is to ensure that a transfer of water does not increase the total amount of water consumed, rather it allows for the shifting of water use from one party to another. This is an important distinction. The transfers are meant to facilitate the movement of water to the highest use, or that use which can afford it especially in dry times. If the transfer criteria allowed the seller to continue to consume the same amount of water, then the system as a whole would be consuming more water during dry times; an obviously counter-productive policy.

The Project being contemplated by USBR and others specifically allows the sellers to replace the transferred water through ground water substitution (see for example ES.3 - ES.4). Hence, the Project is by definition, at least in part contrary to the controlling statute under which the transfers are being contemplated. In the abstract, one could evaluate any transfer wherein the seller replaced the transferred water with another source and estimate the impacts and potentially mitigate the impacts. However, CVPIA as an expression of Congressional intent, has already made the determination that transfers dealing with CVP water shall not result in any total increase in use. Thus the draft EIS/R’s analysis of what the impacts of such substitution might be and how they might be mitigated is irrelevant. No transfers which allow the seller to continue to consume any portion of the amount of water being transferred are legal.

It does not matter that the Project intends to allocate a portion of the transfer water to instream or ground water replacement. Any of the Project’s transfers which are based on substituting ground water (or any other source) are prohibited under Public Law 102-575.

2. Transfers under the Project which allow ground water substitution appear to violate CVPIA’s mandate that any transfer have no significant impact on the seller’s ground water.

CVPIA Section 3405 (a)(1)(J) states that no transfer shall be approved unless it is determined that “such transfer will have no significant long-term adverse impacts on groundwater conditions in the transferor’s service area.” Although the draft EIS/R includes an analysis of impacts to ground water in proposed sellers’ areas (see attachment hereto criticizing the DEIS/R analysis), it clearly concludes that specific impacts are not susceptible to determination. Therefore the Project proposes significant monitoring to evaluate the actual effects on ground water levels, and subsequent measures to insure protection of the underlying basins. However, planning to evaluate the impacts of ground water substitution (or other methods of “funding” transfers) is clearly not a determination that any such transfer will have no significant long-term effects on the underlying basins. To comply with the provision of CVPIA, the Bureau would have to arrive at some level of certainty that actions like ground water substitution will indeed not adversely affect the transferor’s basin. Future efforts at determining whether or not the basin will be affected are inadequate under the statute. Future mitigation does not insure no harm.

2

3

Mr. Brad Hubbard
 December 1, 2014
 Page - 3 -

3. The Project is contrary to and does not examine CVPIA's mandate to restore anadromous fish populations.

Another provision of CVPIA requires the establishment of an anadromous fish restoration program, or AFRP. This program was developed and adopted by the Fish and Wildlife Service in consultation with the Bureau and other state and federal agencies. The program must double the populations of certain specified fish species. (see webpage http://www.fws.gov/sacramento/fisheries/CAMP-Program/Home/Documents/Final_Restoration_Plan_for_the_AFRP.pdf) This program includes recommended higher flows on many rivers including various small and all the main tributaries to the Sacramento and San Joaquin Rivers (see webpage http://www.waterboards.ca.gov/waterrights/water_issues/programs/bay_delta/bay_delta_plan/water_quality_control_planning/docs/sjrf_spprtinfo/afrp_1995.pdf)

The amounts of flows recommended by the AFRP are significantly higher than currently mandated flows and would necessitate significant "new" sources of water. Since the precipitation in any particular year is finite, to get the increased flows for the AFRP program the Bureau (or FWS or NMFS) would need to purchase water from upstream interests, including not only those who operate other dams on various tributaries, but also current CVP contractors who claim rights to some of that additional supply.

The Project anticipates the transfer of water from the same supply from which AFRP water must come. Hence, the Bureau is moving forward with a program that will prevent it from meeting its federally mandated obligation to double anadromous fish. Although the Bureau may be allowed to move forward on numerous projects and activities at the same time, undertaking a "voluntary" project that will preclude it from meeting a federally mandated obligation is not proper or legal. At a bare minimum, the DEIS/R must examine how the proposed Project will, and to what extent, affect the success of the AFRP. Absent a detailed analysis of this renders the DEIS/R insufficient.

4. The Project is contrary to and does not examine its effects on compliance with other federal law.

In 2004, Congress passed and the President signed into law the "Water Supply, Reliability, and Environmental Improvement Act" (hereinafter "2004 Act") commonly referred to as HR 2828 or Public Law 108-361 (see webpage <https://www.govtrack.us/congress/bills/108/hr2828/text>). This statute mandates various duties to the Bureau and other federal agencies with regard to water issues and uses in California.

The 2004 Act required the Bureau to develop a plan to meet all existing water quality standards and objectives for which the (CVP) has responsibility (2004 Act Section 103 (d)(2)(D)(I)). The Bureau (which holds the State issued permits to operate the CVP in California) is assigned the responsibility for meeting numerous water quality standards/objectives. These objectives include not only Delta outflow or X2, but also water flow and quality standards on the San Joaquin River and in the southern Delta. The Bureau must meet fishery flow standards measured at Vernalis during various times of the year, and must meet salinity (measured in electrical conductivity, or EC) standards at Vernalis and at three locations in the southern Delta all year round. [The three interior compliance stations are Brandt Bridge on the San Joaquin, Old River at Middle River, and Old River at the Tracy Blvd. Bridge.] These

4

5

Mr. Brad Hubbard
 December 1, 2014
 Page - 4 -

various standards are set forth in the State Water Resources Control Board Decision D-1641 (see webpage http://www.swrcb.ca.gov/waterrights/board_decisions/adopted_orders/decisions/d1600_d1649/wrd1641_1999dec29.pdf).

Compliance with the fishery flow standards requires more water than the Bureau allocates from its reservoirs on the San Joaquin and its tributaries and thus compliance is dependent on there being water purchases. Compliance with the salinity standards also, to varying degrees, is dependent on flows in the river in excess of the amounts the Bureau allocates from its reservoirs. The 2004 Act states that as part of the Program to Meet Standards

“The Secretary shall incorporate into the program the acquisition from willing sellers of water from streams tributary to the San Joaquin River or other sources to provide flow, dilute discharges of salt or other constituents, and to improve the water quality in the San Joaquin River below the confluence of the Merced River . . . and to reduce the reliance on New Melones Reservoir for meeting water quality and fishery flow objectives.” (Section 103 (d)(2)(D)(v))

The Bureau has undertaken no effort to investigate, discuss or identify any willing sellers of water to comply with the above mandates of the 2004 Act nor done any environmental review of such mandatory transfers. Just as it has ignored the AFRP mandates, the Bureau has ignored these mandates and is now identifying potential sellers on the San Joaquin System to transfer water for export to CVP contractors. Again, the finite amount of water produced each year means that the Bureau is acting in a manner which precludes it from meeting federally mandated obligations contained in the 2004 Act. The DEIS/R make no analysis of how the Bureau intends to meet its permit obligations contained in D-1641 or how the Project might affect its ability to meet those obligations. As will be seen below, since the Bureau regularly violates its obligations to meet water quality standards its efforts associated with the Project are clearly frustrating not only the law, but in violation of the Bureau’s permit and statutory obligations.

5. By undertaking the Project, the Bureau is choosing to not meet its permit obligations to meet water quality standards, contrary to the assumptions in the DEIS/R.

Since 2007, California has experienced two significant dry periods. 2007 and 2008 were a dry and an critical year. 2009 started off as being another critical dry year until some rains, especially in February eased the situation. 2012 was a below normal year with 2013 being one of the driest years on record. Those extremely dry conditions continued through 2014. In each of these dry periods, the Bureau (and DWR) were unable to meet their permit conditions for fishery and other water quality standards. The full extent of the hydrological conditions, reservoir operations and the lack of compliance with specific project obligations is too voluminous to repeat here. Reviewing the relevant SWRCB documents (see attached TUCP, http://www.swrcb.ca.gov/waterrights/board_decisions/adopted_orders/orders/wro2009.shtml) and the attached correspondence between CDWA and SWRCB provides a much more detailed summary. With that said, the following summarizes recent failures of the Bureau to meet its obligations. After a two year drought from 2007-2008, the Bureau, according to its own petition before the SWRCB, had insufficient water in storage to fully supply its highest priority contractor (the Exchange Contractors) and was unable to meet Delta outflow (X2) requirements beginning in early 2009. After a below normal year in 2012 and six months of virtually no precipitation in 2013, the Bureau was unable to meet and sought relief from its obligations to meet the Western Delta agricultural standard and the cold water requirements for Sacramento River fisheries. In 2014, as the drought continued, the Bureau was unable to meet outflow (X2), unable to meet cold

5

6

Mr. Brad Hubbard
 December 1, 2014
 Page - 5 -

water requirements, unable to meet the spring Vernalis fishery pulse flow standard, unable to meet the Vernalis salinity standard, unable to meet the three interior southern Delta salinity standards and unable to meet the fall Vernalis fishery pulse flow standard. [See for example attached Notices of Violation and EC data from DWR webpage.]

6

This “drought-related” problem is unfortunately not just a function of droughts. The Bureau has also failed to meet the spring fishery pulse flow at Vernalis on a number of occasions and most every year violates the salinity standard at Old River at Tracy Blvd. Bridge. [See attached DWR 2013 and 2014 Water Quality Data] The underlying reason for the Project is to find additional supplies for CVP contractors during years when they do not get enough water under their CVP contracts. It is precisely those years that the Bureau is incapable of meeting its permit obligations to maintain water quality standards. However, instead of taking actions to meet its obligations, the Bureau instead embarks upon a program to find water to provide additional exports. Thus the Bureau has unlawfully elevated export contractor desire for additional water above the Bureau’s existing obligations to protect fisheries and other beneficial uses. Although the Bureau’s permits condition the delivery of water to its contractors on compliance with all other permit conditions, the Bureau consistently fails to do so. By undertaking the Project, the Bureau is insuring that not only will it not be able to meet its obligations in following years, but it is also making compliance even less likely and violations more severe. There is only so much water in the system. When the Bureau seeks to facilitate transfers of portions of the limited supply to satisfy contractor desires, it necessarily decreases the amount of water available to meet standards. It is important to note that in precisely the years when there is insufficient water to meet permit and other obligations for the protection of water quality, the Project will increase the consumptive use as a whole by allowing sellers to substitute their water supply to fund a transfer.

7

The DEIS/R purports to examine the Project’s effects on stream flow and other waters, but it makes no analysis of how the Project will affect Bureau (and DWR) mandated obligations to meet water quality standards. The DEIS/R, like so many other environmental documents simply assumes that standards will be met and ignores the reality of the water supply. As we have seen so clearly in the past 8 years, DWR and the Bureau operate to not meet the standards.

6. The DEIS/R does not adequately examine the effects of the additional pumping on southern Delta water levels, quality or circulation.

Export pumping at the SWP and CVP facilities in the southern Delta adversely affects flows, water levels and quality in the southern Delta and central Delta. [See attached 1980 Report of Effects of CVP]. The DEIS/R reasons that as long as the Bureau and DWR comply with their existing permit conditions and applicable SWRCB orders, no party is harmed. Thus additional projects, like the contemplated Project will also not cause third party harm. That is to say, if the current regulations on exports protects third parties, those same regulations will prevent any harm from any exports done under altered, but allowed exports. DWR and the Bureau intend to continue compliance with the regulatory scheme. Such assertions are incorrect.

8

Operations under current CVP permit conditions do cause harm. The SWRCB has *partially* addressed some of these third party impacts caused by the CVP and SWP in a Cease and Desist order issued against the projects (and subsequently amended). The Cease and Desist Order is WR Order 2006-0006 and its modification is WR Order 2010-0002, both can be found at http://www.swrcb.ca.gov/waterrights/board_decisions/adopted_orders/orders/wro2006.shtml. This Order places limits on export operations, including those wherein the Bureau would use

Mr. Brad Hubbard
December 1, 2014
Page - 6 -

SWP facilities as is contemplated in the Project. The 2006/2010 Order requires the Bureau and DWR to develop water level and quality response plans, the latter of which requires the agencies to give notice of anticipated water quality violations and of actions undertaken to avoid such violations. The Order specifically lists the purchase of additional water for flow on the San Joaquin River as one potential mechanism to meet the standards. The Order also requires those agencies to give notice of actual violations and specify what actions were indeed taken to correct or minimize the violation. To date, DWR and USBR have generally failed to give the appropriate required notice and have taken no additional actions to prevent or minimize violations of water quality standards. The standards are regularly violated.

8

Levels.

The hydraulics of the southern Delta channels are very complicated and difficult to understand. In general, the operation of the SWP and CVP export pumps draw down local water levels to the point where it affects the ability of local diverters to operate their diversion pumps or siphons. The extent of the effects at any particular time are dependent on how much export pumping is occurring, inflow from the San Joaquin River, tidal flows, when (during the tidal cycle) the pumping is occurring, the existence of the temporary tidal barriers¹ and the depth and capacity of any particular channel. Although there is a “water level response plan” as required by the CDO as referenced above, that response plan only applies to times when the CVP is using the SWP pumps or vice versa (this use of the other’s facilities is known as joint point of diversion, or JPOD). There is no response plan during other times, yet exports continuously adversely affect local diverters as the barriers are not a complete mitigation and are not installed and operated at all times. Even during times when the response plan is in effect, the practice of the Bureau and DWR is to operate in a manner that harms local diverters.

As can be seen in email and modeling charts provide by DWR/USBR in just this last month (see attached JPOD information), rather than comply with the mandatory seven-day notice requirement in the response plan, the projects “asked” to implement JPOD sooner than the mandated seven days. The modeling provided indicated that they intended to go forward with the JPOD since the water levels would be too low (adversely affect local diverters) anyway, and thus the JPOD was only a minor additional harm, and not significant. It is SDWA’s position that when water levels are at the point where they adversely affect local diversions, no additional export pumping should be allowed as it only adds to the harm. None of this is mentioned must less analyzed in the DEIS/R.

9

This adverse impacts on levels from export pumping is graphically evidenced this past summer. When exports were at historic lows this summer, diverters along Tom Paine Slough had adequate water levels in the Slough. In all prior years, when exports were significantly higher, the Slough did not fully fill on the incoming tide and the diverters were often times incapable of diverting when needed. [See attached Tom Paine Slough data.] Under the Project, additional export pumping will occur, but the impacts to southern Delta diversions is completely unexamined. The DEIS/R is therefore insufficient for two reason. The first is that it makes no inquiry into how increased exports might affect southern Delta diverters ability to divert, and

¹ Three rock barriers are installed in the South Delta each year from approximately April through November. These barriers are meant to mitigate export effects on water levels by allowing incoming tides to fill the channels but then preventing the ebb tide from lowering water levels.

Mr. Brad Hubbard
 December 1, 2014
 Page - 7 -

second, it wrongfully assumes that existing compliance with regulatory limitations on export pumping means there is no harm caused by current export pumping levels.

9

Quality.

It is a similar situation with regards to water quality. First, the DEIS/R makes no mention of the impacts to EC at any of the three interior southern Delta compliance stations where the SWRCB Water Quality Control Plan objectives are measured. The DEIS/R does give information about changes at Vernalis, but again, ignores the three objectives downstream of Vernalis. As stated before, the hydraulics of the area are complicated. Southern Delta salinity (measured in EC) is a function of the salt which flows into the area from the San Joaquin River, local use, riverine evapo-transpiration, incoming tidal flows (and the salt contained therein), and flow changes due to export pumping. As referenced above and in the attached materials, the salinity standard measured at Old River at Tracy Blvd. Bridge is commonly violated.² The DEIS/R seems to accept these violations as a base case or accepted practice. By assuming this, the DEIS/R does not fully explain how the current conditions are causing harm to third parties or what or how the incremental effects of the project may also cause harm. The DEIS/R simply assumes current exports and additional exports under the Project do not affect third parties.

10

Importantly, the DEIS/R notes in Table 3.2.26 that water quality is sometimes worse under the Project at Clifton Court Forebay, the intake for the SWP export facility. If water quality is worse at this location, that means the dilution benefits of the incoming tide are less and the water quality upstream (where the three interior south Delta salinity standards are measured) is necessarily worse, and the resulting impacts unknown.

Circulation.

The DEIS/R has no analysis of how any changes in San Joaquin River flows or export levels will affect flow pattern in the southern Delta. As stated above, flows in the area are a function of many things including exports and inflow from the San Joaquin River. Even small changes in either one of these can have significant effects on flow patterns. This is true even during times when the tidal barriers are installed and operating. The barriers are designed and operated in a manner that provides the maximum protection from decreased water levels while also trying to minimize salt from concentrating in the area. The barriers are most efficient at certain levels of inflow as that inflow helps determine how much diluting tidal inflow will enter the area. A complete explanation of these issues is contained in the DWR documents at http://baydeltaoffice.water.ca.gov/sdb/tbp/index_tbp.cfm (The temporary barrier project site) and http://baydeltaoffice.water.ca.gov/sdb/sdip/index_sdip.cfm (The South Delta Improvement Program site which includes the final EIS/EIR for that project). The documents at these sites are incorporated herein as the underlying technical background of how the southern Delta flow is understood and barrier operations occur.

11

² The attached Salinity Measurements material shows DWR information indicating the measured EC at the four compliance stations as well as the 30-day running average. The standard is a 30-day running average of 1.0 EC (September - March) and 0.7 EC (April - August). Thus, any time the 30-day running average in the attached materials exceeds 1.0 EC from September - March or 0.7 EC from April - August there is a water quality violation.

Mr. Brad Hubbard
 December 1, 2014
 Page - 8 -

7. The DEIS/R does not adequately examine the impacts of transfers from the San Joaquin River system or how diversions of such transfers upstream of the Delta affect third parties.

Table 3.2.25 on page 3.2.38 of the DEIS/R shows decreases in San Joaquin River flow under certain modeling conditions for various months in differing year types. Initially it must be noted that these numbers are averages for the year types. Though potentially helpful in analyzing impacts (assuming the modeling is correct and reliable) any average result is misleading because it mixes the lowest flow with the highest. Thus we cannot see what the lowest flow in any month is only the average of all flows from a set of years for that month. Impacts at these lower flows are therefore not examined and no conclusions should therefore be made about how the project may or may not injure third parties.

The information provided indicates that in some years San Joaquin River flows can decrease (for example) under the Project by up to 84 cfs in June and up to 81.3 cfs in March. These decreases can be significant in that flows on the River are sometimes very low. In the past year alone, Vernalis flow has dropped to 219 cfs in July (see attached DWR Flow Export data). Any change in such low flow would be very significant. Although the decreases in Table 3.2.25 are shown in above normal years, not knowing the flows in all years prevents us from determining if there are decreases in River flow during drier times under the Project.

The project also anticipates potential diversions of transfer water upstream of Vernalis and between Vernalis and the Delta proper (the later at the diversion of the Banta-Carbona District intake). The DEIS/R makes no real analysis of how such diversions would affect flow or water quality when the water enters the Delta (downstream of the Banta-Carbona intake). The San Joaquin River suffers from decreased flows (see 1980 Report attached hereto) and severe salinity problems due to drainage (surface and subsurface) from the CVP service area (see 1980 Report and Salinity in the Central Valley at www.waterboards.ca.gov/centralvalley/water_issues/salinity/central).

Much of the salt entering the San Joaquin River occurs upstream of the River's confluence with the Merced River. Generally, the Merced and other tributary flows downstream provide some dilution to the saline San Joaquin. Depending on where and when the Project might allow diversions along the River (of transferred water) determines the effects on the water quality of the water which eventually enters the Delta. As we have seen, the water quality standards in the Delta are often violated, which means that any change in salinity and flow could affect water quality especially at the locations where the violations occur. Both the amount of inflow and the load of salt are important given the manner in which the CVP and SWP cause salt to collect and concentrate in the southern Delta. In addition, New Melones dam/reservoir on the Stanislaus is used to control salinity on the San Joaquin River at Vernalis through releases. However, New Melones is not operated to meet the standards in the southern Delta. The DEIS/R must examine how any changes in flows due to diversions of transferred water upstream of the Delta (at Banta Carbona's intake and above) affect releases from New Melones and how it may affect interior southern Delta water quality. The DEIS/R does neither.

It is important to note that although the salinity standards are measured at four compliance locations, the standards apply throughout the channels at all locations (see SWRCB 2006 Water Quality Control Plan at page 10; http://www.waterboards.ca.gov/waterrights/water_issues/programs/bay_delta/wq_control_plans/2006wqcp/index.shtml)

12

13

Mr. Brad Hubbard
 December 1, 2014
 Page - 9 -

The DEIS/R does not even cover New Melones storage impacts which might occur due to changes in San Joaquin River flows or quality. Since the 2004 Act requires the Bureau to decrease New Melones use for meeting water quality standards, the DEIS/R is clearly incomplete and inadequate.

13

8. The DEIS/R is an improper “piecemealing” of a project under CEQA and NEPA.

According to the November 2013 Draft EIR/EIS for the Bay Delta Conservation Plan (BDCP), “Conveyance of transfer water by Authorized Entities is a covered activity provided that the transfers are consistent with the operational criteria described in CM1 and the effects analysis described in BDCP Chapter 5, Effects Analysis.” (BDCP DEIR/EIS, p. 3-120; see excerpts enclosed herewith.) Because the BDCP will not only facilitate CVP water transfers, but will expressly include them as “covered activit[ies],” under CEQA and NEPA those transfers must be evaluated within the EIR/EIS for the BDCP and not in a separate, independent EIR/EIS.

With regard to CEQA, as the court explains in *Orinda Assn v. Board of Supervisors* (1986) 182 Cal.App.3d 1145, at page 1171:

A public agency is not permitted to subdivide a single project into smaller individual sub-projects in order to avoid the responsibility of considering the environmental impact of the project as a whole. “The requirements of CEQA, ‘cannot be avoided by chopping up proposed projects into bite-size pieces which, individually considered, might be found to have no significant effect on the environment or to be only ministerial.’ [Citation.]”

As the court in *Berkeley Keep Jets Over the Bay Committee v. Board of Port Com’rs* (2001) 91 Cal.App.4th 1344, similarly explains:

14

There is no dispute that CEQA forbids “piecemeal” review of the significant environmental impacts of a project. This rule derives, in part, from section 21002.1, subdivision (d), which requires the lead agency . . . to “consider[] the effects, both individual and collective, of all activities involved in [the] project.”

Moreover, in a similar vein, as the California Supreme Court explains in *Laurel Heights Improvement Assn. v. Regents of University of California* (1988) 47 Cal.3d 376, at page 396:

We hold that an EIR must include an analysis of the environmental effects of future expansion or other action if: (1) it is a reasonably foreseeable consequence of the initial project; and (2) the future expansion or action will be significant in that it will likely change the scope or nature of the initial project or its environmental effects.

CVP water transfers are indeed a “reasonably foreseeable consequence” of the BDCP (for among other reasons, they are in fact a “covered activity” under the BDCP), and those transfers will indeed “likely change the scope or nature of the initial project or its environmental effects.” With regard to the latter, the November 2013 Draft EIR/EIS for the BDCP itself acknowledges that the scope of the BDCP would indeed change if CVP water transfers were added to the scope of that EIR/EIS. As that Draft EIR/EIS explains: “[T]he withdrawal of transfer waters from source areas is outside the scope of the covered activity.” (BDCP Draft EIR/EIS, p. 3-120; see

Mr. Brad Hubbard
 December 1, 2014
 Page - 10 -

excerpts enclosed herewith.) Hence, if such withdrawal of transfer waters were included within that scope, it would undisputedly constitute a (significant) change of the scope of the BDCP Draft EIR/EIS (and, hence, its environmental effects).

14

For these reasons, the instant EIS/EIR is contrary to both CEQA and NEPA. The environmental analysis of the CVP transfers must be undertaken within the pending EIR/EIS for the BDCP and not separately from that EIR/EIS.

9. The DEIS/R incorrectly assumes there will be no transfers from 2015-2014 absent the Project.

On page 2-6 (section 2.3.1) and other places in the DEIS/R is it noted that the Base Case/No Action Alternative assumes no transfers during 2015 - 2024. There is no support for this assumption. Even in this second year of significant drought, the Bureau and DWR conducted JPOD operations of transfer water (see attached JPOD). If such transfers occur under current conditions they will certainly occur sometime in the next 10 years under the Base Case. I note that per the language of CVPIA, any water that moves via CVP facilities is considered "CVP water" and thus comes under both the Project and CVPIA limitations.

15

10. The DEIS/R is inadequate in that it is impossible to determine water savings under the crop shifting method of supplying transfer water.

One of the methods of supplying transfer water is to account for the amount of water saved by a seller due to a shift of one crop to another that consumes less water. Since transfers are to provide supply in drier times, there is no way to know if the seller would have shifted to that crop anyway because of such drier times. In this past year the SWRCB curtailed all post-1914 water rights and publically considered curtailing pre-1914 water rights, riparian rights and even CVP and SWP contract rights (deliveries). Hence, the pressures of drought can and do affect farming decisions in all areas, including those identified as potential sellers under the Project. There is no method to accurately determine if a seller would have shifted to a different crop absent a transfer, which makes the Project incapable of analysis and precludes any calculation of "how much water was saved."

16

This issue also is affected by the DEIS/R's failure to review water rights issues associated with any seller. If a seller is getting water from the CVP under a settlement or exchange contract, is the water he uses from his right or from the contract? Is he getting contract water in excess of what his underlying water right would provide under "natural conditions?" Is he making decisions on acreage and crops based on the contract or underlying water right? Does the decision on water use depend on what right is used? Until this morass of issues is resolved, there is no method by which one can determine if a crop shift actually results in more water being available.

11. The DEIS/R incorrectly assumes the CV-SALTS process will decrease salt entering the southern Delta.

One of the assumptions used to minimize, ignore or not examine the Project's impact on southern Delta salinity is that the CV-SALTS process will decrease the amount and concentration of salts entering the San Joaquin River. This indicates a misunderstanding of the CV-SALTS process. CV-SALTS is a joint SWRCB, CVRQWCB and stakeholder effort to address the valley/River salt problems. Although the process is developing Basin Plan amendments which can/could limit discharges of salt, the main thrust of the effort is to find a way to get the valley

17

Mr. Brad Hubbard
December 1, 2014
Page - 11 -

salts out to the Bay and Ocean. Hence, rather than decrease salt loads, the implementation of the Basin Plan will be through a real time monitoring/discharge program already being developed by the Bureau and stakeholders. Under such a program, Highly concentrated salts will be discharged to the River during times when the River is of better quality than the discharge, and such mixing will not exceed the standard. Hence, the plan is to spread the salts out over time so that times of better water quality will be degraded, not improved. The times when the concentration is already too high will not be affected as New Melones currently dilutes the River regardless of the salt concentration. In sum, the San Joaquin River will not improve under the CV-SALTS program, the salts will simply be spread out, degrading the River at all times. The same amount of salts will enter the south Delta as do now. Whether or not those salts will leave the area or be adequately diluted for local use remains unknown, unexamined and unplanned. (See webpage www.cvsalts.com.)

17

12. Additional comments and analysis are attached.

Attached hereto are more specific comments relating other portions of the DEIS/R, and a technical analysis done by E-Pur, LLC (engineering consultants) focusing mainly on the ground water/surface water modeling done in support of the DEIS/R. Each indicate that the DEIS/R inaccurately analyzes the impacts Project and/or does not use the best science available.

Very truly yours,

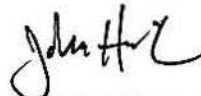

JOHN HERRICK

Long-Term Water Transfer Public Draft EIS/R Comments

EIS/R Document Comments

- Pg ES-1, par3 – There is no evidence to support or assure that Buyer’s use will be beneficial. Application of water to lands with particularly high latent levels of selenium or boron which further directly degrade the San Joaquin River or cause degrading accretions to the San Joaquin River would not be beneficial.. 18
- Pg ES-1, par3 – There is no evidence to support or assure that the transfer water is not going to “service any new demands”. Water used to irrigate new plantings of permanent crops or even an annual crop not yet planted is serving a new demand. As permanent crops mature water demand generally increases and constitutes a new demand. For M&I type uses new connections and increases in use of existing connections adds new demand. 19
- Pg ES-1, par4 – SLDMWA is the state lead agency. The SWP operations and facilities are an integral part of the proposed project implementation. DWR must operate the SWP to accommodate these transfers and will be responsible for identifying when excess capacities exist to create the transfer opportunity in the first place. DWR is also the permit holder for the right to operate the SWP that mitigate for the SWP operations. SLDWMA assistance in negotiating transfer agreements between parties is hardly a superior qualification for them as lead agency over DWR who has to operate the system to make the transfers happen. DWR should be the state lead agency. 20
- Pg ES-2, par2 – Other concurrent transfers must be considered for the projects affects on those operations, both directly and indirectly as well as in combination and cumulatively with them, e.g. Lower Yuba River Accord water transfers from YCWA. 21
- Pg ES-2, par4 - The Purpose and Need limits the consideration to transfers from upstream of the Delta to water users south of the Delta and in the San Francisco Bay. This improperly limits the objective consideration of all reasonable alternatives. Measures other than transfers and measures including transfers within the Buyer area or other parts of the State present reasonable alternatives.. 22
- Pg ES-2, par6 – Water transfers are only one potential method to meet supplemental water supply objectives. Water recycling, water conservation, and within water buyer district local conjunctive use, transfers, and land retirement are all other reasonable and effective alternative methods to satisfy this objective. 23
- Pg ES-2, par8 – The premise that the water transfers will occur to make up for regulatory constraint impacts on water supplies is fundamentally flawed. The failure of the projects to develop sufficient supplies to meet regulatory requirements, senior obligations and project contractor desires is the driver. Buyer’s desire to acquire through water transfers water which is not truly surplus to the needs within the watersheds of origin. 24
- Pg ES-3, figure ES-1 – New Melones storage facilities and the Stanislaus River are identified as a potential conveyance for the proposed project, but no potential sellers have been identified in this watershed and no “Area of Analysis” (Table ES-2) was included for this geographic area. 25

Without a willing seller identified with New Melones water rights or water rights in the Stanislaus River basin, the New Melones facilities and the Stanislaus River should not be involved in the proposed project. This was not disclosed in the EIS/R. Since this geographic area and facility was not analyzed or impacts disclosed, the New Melones facilities and the use of the Stanislaus River cannot be covered under this environmental document or for agency decisions or permits issued based on this document.

- Pg ES-3, figure ES-1 – The figure and project description fail to identify the water conveyance routes that could be utilized (and which could precipitate different environmental impacts. Without identifying the route in which surface water flows would be affected by the project, there cannot be a proper project level impact analysis. Such impacts have not been adequately identified, characterized, evaluated, quantified, mitigated or disclosed.
- Pg ES-5, par ES 2.2 – The willing sellers are not described in any detail (like the buyers were), they were only included on a list. The map of willing sellers is not sufficiently detailed to determine who is where. As an example, the area south of the town of Davis cannot be determined as to who the land owner(s) may be. Regardless, no conveyance route to deliver the water for a transfer is identified or analyzed for this water transfer so the impacts for the transfers from this property are not disclosed in or covered by this environmental document.
- Pg ES-8, par ES 3.2 – Alternatives should have included all reasonable measures, including land retirement, within the Buyer area as well as areas of the State other than upstream of the Delta..
- Pg ES-9, Table ES-3 – Crop shifting – crop shifting and idling appear to be used interchangeable in the document in terms of creating water supply, but the environmental impacts of them are significantly different in kind and magnitude. The analysis must clearly separate the location, timing, and magnitude of each of these water conservation strategies and address their separate types and magnitudes of impacts.
- Pg ES-9, Table ES-3 – Even with the improperly limited alternatives there should have been an alternative 5 which included all other water supply source concepts except seller service area crop idling and shifting so seller service area agricultural impacts from the water transfers could have been identified, characterized, quantified and disclosed. As the alternatives stand, all of the alternatives, except the no action, included seller service area agricultural conservation. This alternative must be included in the revised EIS/R so these impacts can be isolated and quantified and compared to the other alternatives.
- Pg ES-9, Table ES-3 – Even with the improperly limited alternatives there should have been an alternative 6 which included all other water supply sources except reservoir releases so reservoir release impacts from the water transfers could have been identified, characterized, quantified and disclosed. Isolating the impacts of storing and conveying water is essential to complying with the requirements of the Warren Act Contract assessment. As the current analysis stands, all of the alternatives except the No Action/No Project included reservoir releases so these CVP reservoir-related water wheeling related impacts cannot be separated from the other project impacts in order to satisfy Warren Act analysis requirements.

25

26

27

28

29

30

31

- Pg ES-9, Table ES-3 – Since most willing sellers identified are part of the CVP and SWP, these contractors will also be short on water allocations in years in which the buyers would want to do water transfers. Since the sellers would be short on water supply in these years, they would already be doing the feasible water conservation actions, shifting to less water consumptive crops, idling farmland and utilizing groundwater as an alternative water supply to their surface water rights. Therefore, the proposed project and other alternative which rely upon seller service area water conservation, crop fallowing, crop shifting and use of alternative groundwater water supply assumptions are fundamentally flawed and unrealistic. Much of the water saving that the project is going to take credit for transfer would already be happening (switching to lower consumptive crops, idling land and switching to groundwater), so the project is claiming false credit for water conservation. The EIS/R must show, defensibly, how the water claimed as saved is actually saved, above and beyond what was going to happen absent the project.
- Pg ES-9, ES 4 par 2 – “The biological opinions on the Coordinated Operations of the CVP and SWP (U.S. Fish and Wildlife Service [USFWS] 2008; National Oceanic and Atmospheric Administration Fisheries Service [NOAA Fisheries] 2009) analyze transfers through the Delta from July to September (commonly referred to as the “transfer window”) that are up to 600,000 AF in dry and critically dry years. For all other year types, the maximum transfer amount is up to 360,000 AF.” This statement is correct as to the USFWS OCAP BO, but the NMFS OCAP BO has no similar provision or language. This erroneous assumption/representation distorts the EIS/EIR analysis of impacts to species covered in the NMFS OCAP BO.
- FWS OCAP BO pg 229, p1, “Water transfers would increase Delta exports by 0 to 360,000 acre-feet (AF) in most years (the wettest 80 percent of years) and by up to 600,000 AF in Critical and some Dry years (approximately the driest 20 percent years). Most transfers will occur at Banks (SWP) because reliable capacity is not likely to be available at Jones except in the driest 20 percent of years. Although transfers can occur at any time of year, the exports for transfers described in this assessment would occur only in the months July-September.” The proposed project transfers from April through June are not covered in the FWS OCAP BO impact assessment of water transfers so the proposed project water transfers that would occur in April through June must seek ESA consultation from FWS.
- FWS OCAP BO pg 229, p1, “Delta smelt are rarely present in the Delta in these months, so no increase in salvage due to water transfers during these months is anticipated, but as described above, these transfers might affect delta smelt prey availability.” This is why the FWS OCAP BO analysis of impacts of CVP and SWP water transfers in July through September are covered by the current take permits and any other months are not.
- FWS OCAP BO pg 229, p4, “The pumping capacity calculated is up to the allowable E:I ratio and is limited by either the total physical or permitted capacity, and does not include restrictions due to ANN salinity requirements with consideration of carriage water costs.” So the transferred water is allowed to degrade water quality because the flows to maintain salinity standards would cost too much?
- FWS OCAP BO pg 230, p1, “For all other study years (generally the wettest 80 percent) the available capacity at Banks for transfer ranges from about 0 to 500 TAF (not including the additional 60 TAF accruing from the proposed permitted increase of 500 cfs at Banks. But, over the course of the three months July-September other operations constraints on pumping and

32

33

34

35

36

37

occasional contingencies would tend to reduce capacity for transfers. In consideration of those factors, proposed transfers would be up to 360 TAF in most years when capacity is limiting.” The project description of the proposed project is not specific as to how much of the potential 511,000+AF are proposed to be transferred by water year type. Therefore, the project description is inconsistent with the limitations for water transfers set in the FWS OCAP BO.

- FWS OCAP BO pg 230, p3, “for this assessment proposed exports for transfers (months July-September only) are as follows:

Water Year Type	Maximum Amount of Transfer
Critical	up to 600 kaf
Consecutive Dry	up to 600 kaf
Dry after Critical	up to 600 kaf
All other Years	up to 360 kaf”

Note that the FWS OCAP BO addresses these transfer amounts only during the period of July through September.

- NMFS OCAP BO pg 729 p3, “...this consultation does not address ESA section 7(a)(2) compliance for individual water supply contracts. Reclamation and DWR should consult with NMFS separately on their issuance of individual water supply contracts, including analysis of the effects of reduced water quality from agricultural and municipal return flows, contaminants, pesticides, altered aquatic ecosystems leading to the proliferation of non-native introduced species (*i.e.*, warm-water species), or the facilities or activities of parties to agreements with the U.S. that recognize a previous vested water right.”, The NMFS OCAP BO appears to provide that the water transfer seller and recipient agencies will require ESA consultation.
- Pg ES-10, ES 4.1 – Specific measures are not set forth to assure that the Seller substitutes groundwater for surface water..
- Pg ES-10, ES 4.2 – “Reclamation would limit transferred water to what would not have otherwise been released downstream absent the transfer.” Specific measures to assure that this is the case are not spelled out.
- Pg ES-10, ES 4.2 – “Each reservoir release transfer would include a refill agreement between the seller and Reclamation (developed in coordination with DWR) to prevent impacts to downstream users following a transfer.” “Refill of the storage vacated for a transfer may take more than one season to refill if the above conditions are not met in the wet season following the transfer.” The reduction in storage from the transfer, that according to the document could take years to replace, could cause significant impacts to downstream users, reservoir resources (recreational boat launch access and marinas, warmwater fisheries reproduction success, exposure of sensitive archaeological sites in the reservoir fluctuation zone and other significant impacts). The project must only be allowed to release water it has already stored, not release water that it does not yet have as appears to be proposed by the project. If the project is only allowed to release water it has already stored then the impacts to other resources are dramatically reduced. If the release only of water that is already stored is not a part of the project description, it must be a requirement for mitigation of the impacts caused by releasing water before it is stored.
- Pg ES-11, ES 4.3 – If weed cover is not removed then the consumptive use conservation the project claims to be using for the water transfer is not supportable..

37

38

39

40

41

42

43

- Pg ES-11, ES 4.3 – Consideration must be given to protecting adjacent properties from herbicide spray drift and weed pressure from fallowed adjacent fields. Mitigation should include monitoring and funding to address these significant project impacts. 44
- Pg ES-11, ES 4.4 – “Transfer water generated by crop shifting is difficult to account for. Farmers generally rotate between several crops to maintain soil quality, so water agencies may not know what type of crop would have been planted in a given year absent a transfer. To calculate water available from crop shifting, agencies would estimate what would have happened absent a transfer using an average water use over a consecutive 5-year baseline period. The change in consumptive use between this baseline water use and the lower water use crop determines the amount of water available for transfer.” Due to the speculative aspects of the determination of true water savings this alternative should be deleted. 45
- Pg ES-12, ES 5 – “The No Action/No Project Alternative considers the potential for changed conditions during the 2015-2024 period when transfers could occur, but because this period is relatively short, the analysis did not identify changes from existing conditions.” Based on this quote from the document, the No Action/No Project baseline is incorrectly defined. The current OCAP Biological Opinions of NMFS and FWS include many Reasonable and Prudent Alternatives and Actions that the CVP and SWP must legally implement during this period. Some of these actions, e.g. bypass flows to inundate floodplain habitat and fish passage, have flow and operational implications that must be included in the No Action/No Project that do not exist (other than current legal obligation) in the Existing Conditions. The EIS/R analysis must be revised to correct for this error in the definitions of the baselines for comparison. 46
- Pg 1-2, 1.1.2 - A project objective identified is, “Develop supplemental water supply for member agencies during times of CVP shortages to meet existing demands. “ New plantings, the maturing of already planted crops, new service connections in M&I areas and increased use of existing service connections are examples of new demand. The analysis is inconsistent with this objective and there are no significant measures to preclude increased reliance on diversions from the Delta. 47
- Pg 1-2, 1.1.2 – “Because shortages are expected due to hydrologic conditions, climatic variability, and regulatory requirements, transfers are needed to meet water demands.” As pointed out in other comments, the regulatory requirements constrain CVP/SWP operations and when CVP/SWP operations are constrained by regulations there is no excess capacity to support water transfers. This component of the project objectives is not satisfied by any of the project alternatives. 48
- Pgs 1-10 & 11, 1.3.1 – “According to the CVPIA Section 3405(a), the following principles must be satisfied for any transfer.”... “Transfer will not adversely affect water supplies for fish and wildlife purposes. “ The impact analysis in the EIR/S identifies several adverse, significant and less than significant proposed project and project alternative impacts to water supplies for fish and wildlife purposes both before and after mitigation. The statute does not limit affects based on significance. The proposed project and its alternatives are in violation of the CVPIA Section 3405(a). 49
- Pg 1-11, 1.3.1.2, – “The biological opinion concluded that continued long term operations of the CVP and SWP, as proposed, were “likely to jeopardize” the continued existence of delta smelt without further flow conditions in the Delta for their protection and the protection of 50

designated delta smelt critical habitat.” As identified in other comments, reverse Old and Middle River flow limitations, X2 and net delta outflow requirements of the FWS OCAP BO RPAs have (theoretically) been implemented, but other required RPAs such as restoration of delta smelt habitat have not been implemented and are obviously not on schedule for compliance. FWS OCAP BO Action 6, “A program to create or restore a minimum of 8,000 acres of intertidal and associated subtidal habitat in the Delta and Suisun Marsh shall be implemented.” “The restoration efforts shall begin within 12 months of signature of this biological opinion and be completed within a 10 year period.” Reclamation and DWR do not appear to have met this requirement in that they have not completed project specific designs for these actions, started project specific EIS/R environmental documents or initiated the permitting or contracting processes to implement this action that is required to be implemented by 2018. Since Reclamation and DWR have failed to implement this RPA, then the species are still in jeopardy and the proposed water transfers would only further exacerbate the conditions that led to the original FWS jeopardy opinion.

50

- Pg 1-11, 1.3.1.2, – “The USFWS developed a Reasonable and Prudent Alternative (RPA) aimed at protecting delta smelt, improving and restoring habitat, and monitoring and reporting results.” Reclamation and DWR have not implemented and complied with many of these RPAs and have missed the deadlines for submitting plans, reports, implementations and accomplishing the specific goals of most of the RPAs. Since DWR and Reclamation have not implemented most of the protections that were designed to protect the ESA listed species for jeopardy, the proposed water transfers will only add to and exacerbate the impact of the CVP and SWP operations on those species, which could only result in further jeopardy to these species.
- Pg 1-11, 1.3.1.2, – “(NOAA Fisheries 2009). This biological opinion concluded that continued long term operations of the CVP and SWP, as proposed, were “likely to jeopardize” the continued existence of Sacramento River winter run Chinook salmon, Central Valley spring run Chinook salmon, Central Valley steelhead, and the southern Distinct Population Segment of North American green sturgeon and were “likely to destroy or adversely modify” designated or proposed critical habitat of these species. NOAA Fisheries also concluded that CVP and SWP operation both “directly altered the hydrodynamics of the Sacramento-San Joaquin River basins and have interacted with other activities affecting the Delta to create an altered environment that adversely influences salmonid and green sturgeon population dynamics.” The biological opinion identified an RPA to address these issues and protect anadromous fish species.” Reclamation and DWR have not implemented and complied with many of these RPAs and have missed the deadlines for submitting plans, reports, implementations and accomplishing the specific goals of most of the RPAs. Since DWR and Reclamation have not implemented most of the protections that were designed to protect the ESA listed species for jeopardy, the proposed water transfers will only add to and exacerbate the impact of the CVP and SWP operations on those species, which could only result in further jeopardy to these species.
- Pg 1-12, 1.3.1.2, – “The Opinions included the following operational parameters applicable to water transfers: A maximum amount of water transfers is 600,000 AF per year in dry and critical dry years. For all other year types, the maximum transfer amount is up to 360,000 AF.” This EIS/R statement is incorrect with regard to the NMFS BO.
- Pg 1-12, 1.3.1.2, – “Transfer water will be conveyed through DWR’s Harvey O. Banks (Banks) Pumping Plant or Jones Pumping Plant during July through September unless Reclamation and/or DWR consult with the fisheries agencies.” The operations of the proposed project may not be altered from what is proposed, analyzed and disclosed in this environmental document or the modification of the BOs must be subjected to subsequent piecemealed environmental analysis of altered impacts.

51

52

53

54

- Pg 1-12, 1.3.2, – “Several sections of the California Water Code provide the SWRCB with the authority to approve transfers of water involving post-1914 water rights.” Since almost exclusively post-1914 water rights would be transferred under the proposed project, all of the applicable SWRCB and CVRWQCB codes must be disclosed. Reference to and compliance with the applicable Basin Plans must be evaluated in the EIS/EIR.
- Pg 1-12, 1.3.2,, – “Section 1725 defines consumptively used water as “the amount of water which has been consumed through use by evapotranspiration, has percolated underground, or has been otherwise removed from use in the downstream water supply as a result of direct diversion.” Evapotranspiration is defined as “the sum of evaporation and plant transpiration from the Earth's land and ocean surface to the atmosphere. Evaporation accounts for the movement of water to the air from sources such as the soil, canopy interception, and waterbodies.” (Wikipedia) When crops are reported by the universities on their total consumptive use to complete a crop cycle, these water use calculations include the water that is resident in the soil profile at planting from natural precipitation and precipitation that occurs during the crop growth cycle. The EIS/R analysis appears to take credit for saving the entire consumptive use of a crop as estimated by the universities. The project fails to take into account in their water savings calculations that a significant fraction of the water consumption for a crop is not saved by simply not planting the crop. Soil and water surface evaporation from precipitation still occurs even if the crop is not there. A certain amount of precipitation that falls is leached below the soil root zone and is lost to groundwater and that occurs if the crop is planted or not. The proposed project and the EIS/R analysis has made an error in taking credit for water saved for the entire evapotranspiration attributed to a crop when the fallowing of a field (provided it is kept free of vegetation) only saves the crop “transpiration” component of the water consumption attributed to a crop, not the “evaporation” component of water consumption that happens whether the crop is planted or not. The water savings credited for water transfer used by the project for “crop idling” and “crop shifting” are wrong and must be corrected to reflect the continued loss of water through evaporation and natural percolation to groundwater. Even the amount of groundwater substitution actually occurring from foregone surface water diversions is wrong in the EIS/R because of the mistaken project use of the entire evapotranspiration associated with a crop. Only the irrigation component of the crop’s total evapotranspiration reported by the university would be saved by the groundwater conjunctive use. The natural precipitation component of the universities reported crop consumptive use would not be saved by the groundwater substitution and cannot be credited to water savings for water transfers as the EIS/R water accounting has proposed. This significant error in the water savings from crop idling, crop shifting and groundwater conjunctive use distorts the analysis and minimizes the impacts to ground and surface water.
- Pg 1-18, 1.5, – “Alternatives considered in this EIS/EIR only analyze transfers of to CVP contractors that require use of CVP or SWP facilities. SWP contractors may also transfer water originating north of the Delta to areas south of the Delta. The cumulative analysis evaluates potential SWP transfers, but they are not part of the action alternatives for this EIS/EIR.” As a result of this statement and how the alternatives have been formulated and analyzed, no SWP contractor can sell water to the project proponents regardless of whether they use CVP or SWP conveyance to deliver it. Only sales of or from CVP contractors that are delivered through the CVP or SWP to the project proponents are covered by this EIS/R or any agency decisions or permits that are issued based on this EIS/R.

55

56

57

- Pg 1-18, 1.5, – “Buyers and sellers must prepare transfer proposals for submission to Reclamation. Proposals must also be submitted to DWR if the transfers require use of DWR facilities or the transfers involve a seller with a settlement agreement with DWR.” The EIS/R fails to define what information must be included with the transfer proposal.
- Pg 1-18, 1.5,– “Reclamation reviews transfer proposals to ensure they are in accordance with NEPA, CVPIA, and California State law.” This statement fails to include that Reclamation must also consider Warren Act Contract requirements when federal facilities are wheeling non-federal water (seller or buyer) through federal facilities. A Warren Act Contract Water Wheeling Assessment is required for any non-federal water from either transfer source or recipient that uses any CVP facility. This would appear to include use of San Luis Reservoir even if only SWP conveyance was used.
- Pg 1-18, 1.5, – “DWR may also be involved in conveying water for transfers and is interested in verifying that water made available for transfers does not compromise SWP water supplies. For water conveyed through the SWP system, DWR must also determine if the transfer can be made without injuring any legal user of water and without unreasonably affecting fish, wildlife, or other instream beneficial uses and without unreasonably affecting the overall economy or environment of the county from which the water is being transferred.” It should be made clear that DWR will be required to develop and approve a separate environmental document for any water transfers that use SWP facilities. San Luis Reservoir is a joint SWP facility so use of these facilities, even if other SWP facilities or water are not involved, should result in the requirement of a separate environmental document from DWR..
- Pg 1-18, 1.6, – The EIS/R omitted that if the project proposes to use SWP facilities DWR has decisions it must make. DWR must decide if there is available capacity, if they will conduct the transfer, and they do decide to do the transfer, they must do an EIS/EIR as the SWP transfers are not covered under the proposed project or any of the project alternatives (see EIS/R section 1.5 and the related comment).
- Pg 2-4, Table 2-1 – Ag conservation in the Buyer Service Area was inaccurately screened. Some types of ag conservation can be immediate, as an example, crop switching and improvements in irrigation scheduling or irrigation system distribution uniformity. Some ag conservation can be nearly immediate, such as improvements to irrigation systems to more water efficient types, e.g. sub-surface drip instead of flood furrow. Each of these ag conservation examples “provides water” for transfer within the buyer area.
- Pg 2-4, Table 2-1 – The alternatives considered failed to include: Increase water conservation for municipal and industrial uses in Seller Service Area to reduce water demands. It would have provided immediate and flexible water supplies as the buyer service area alternative concept to this option determined, but also would have provided water.
- Pg 2-4, Table 2-1 – The determination that reuse of water for ag was not possible for immediate implementation does not appear supportable. This option requires more full investigation for feasibility and consideration in a fair and evenly applied alternatives screening process.
- Pg 2-4, Table 2-1 – Permanent land retirement could be immediate and provides water. It seems a logical compliment to the other concepts of fallowing and crop switching. Permanently retiring marginal farmland has less of an impact than fallowing productive ground. Permanent retirement of land would allow that land to be restored to wildlife habitat. There is no

58

59

60

61

62

63

64

65

significant habitat value to the fallowed field kept free of vegetation as compared to one that is farmed or one that is permanently retired. Retiring land in the buyer service area is part of the No Action/No Project, including additional permanent land retirement in the buyer area should be part of one of the project alternatives..

- Pg 2-4, Table 2-1 – Purchasing water entitlements in the Buyer area is as immediate and creates just as much water as the proposed project long term water transfers. This alternative concept must be fully evaluated in the revised EIS/R.
- Pg 2-4, Table 2-1 – Groundwater substitution should equally apply to the buyer area in the project alternatives.
- Pg 2-4, Table 2-1 –The characterization that not applying rice decomposition water does not result in saving (providing) water is unsupportable. Approximately 350,000 acres of rice is flooded for rice straw decomposition (<http://www.arb.ca.gov/cc/capandtrade/protocols/rice/pbcs-12-20-13.pdf>) and this flooding consumes approximately 175,00AF of water. There are several viable alternatives to applying rice decomposition water including rice straw baling and application of inputs to speed rice stubble decomposition. There are commercially available agricultural inputs that are designed to speed crop residue decomposition (<https://www.soiltechcorp.com/product/stubble-digest/>, <http://www.midwestbioman.com/biocat.htm>). Rice straw decomposition loads can be significantly reduced by baling and removing the rice straw (<http://calrice.org/pdf/Sustainability+Report.pdf>) and is used for erosion control (water quality benefits), cattle feed and power cogeneration (greenhouse gas emission benefit). The best part about this water conservation option (other than the fact it is immediate, flexible and provides water) is that the impacts are beneficial on the local communities by actually increasing the number of jobs rather than destroying them as crop idling does. This project alternative is too good of an opportunity not to be included as an alternative and must be included in the revised EIS/R.
- Pg 2-4, Table 2-1 –Transfer of water stored in CVP or SWP reservoirs should be considered?
- Pg 2-4, Table 2-1 –Transfer of water within a buyer area provides water. This alternative and transfers from areas of the State other than upstream of the Delta should be analyzed.
- Pg 2-4, Table 2-1 –Developing groundwater wells within a buyer service area provides water and implementing them is fairly immediate. This alternative should be analyzed.
- Pg 2-4, Table 2-1 – The EIS/R must include an alternative that includes continuation of one year transfers.
- Pg 2-7, 2.3.1, – The No Action/Project should have included the assumption that single year water transfers would still have occurred absent the proposed project. The lack of the implementation of the proposed project or alternatives does not preclude these single year transfers so the project analysis must be revised to correct the current flawed baseline assumption.
- Pg 2-9, 2.3.2.1, – “A similar case regarding the NOAA Fisheries biological opinion is before the court. If new biological opinions are completed, the new biological opinions or the findings of the NEPA analysis could change the quantity or timing of transfers. If the

65

66

67

68

69

70

71

72

73

74

biological opinions alter the timing and quantity of transfers, the Lead Agencies will determine if supplemental environmental documentation is necessary to address any changes in potential impacts.” An alternative for continuing with short term transfers should be included.

- Pg 2-11, Figure 2-3 – The figure shows water transfers starting approximately May – June (when the lines are diverging), but the FWS OCAP BO only allows transfers from July – September.
- Pg 2-11, 2.3.2.1, – “The seller could request that Reclamation store the non-CVP water in the CVP reservoir until Delta capacity is available, which would require contractual approval in accordance with the Warren Act of 1911.” This statement indicates, as an example, that PCWA could sell water from its’ reservoir, PCWA would release the water when they needed to into their tributary, Reclamation would release less water from Shasta into the Sacramento River during the PCWA release and make the saved Shasta reservoir water available for transfer for the project later in the season. There are multiple fisheries impacts in both tributaries and downstream of them from these interbasin proposed changes in water operations. These inter-basin operational changes to proposed project impacts include changes to water temperature suitability for coldwater fisheries resulting in adverse modification of critical habitat for ESA species, increased fish mortality and reduced fecundity; altered attraction flows and water temperatures for migrating fish causing straying which in turn increases redd superimposition, prespawn mortality, reduced fecundity, egg mortality and genetic introgression. These are all serious significant impacts to endangered species that the EIS/R failed to identify, evaluate, characterize, quantify, mitigate or disclose. The EIS/R must be revised to include these impact analyses and to rectify these material deficiencies in this document.
- Pg 2-12, Table 2-3 – The table assumes that the amount of water saved for each crop is the same regardless if the crop is idled or it is shifted to another crop. If the field is shifted to another crop it will consume moisture from the soil profile and any precipitation that occurs even if it is not actively irrigated. The water savings for shifting a crop is not the same as for idling a crop.
- Pg 2-12, Table 2-3 – The proposed project plan of crop shifting is fatally flawed for its vulnerability to gaming by the sellers. There is nothing in the proposed project to assure that real water savings will be realized by crop shifting.
- Pg 2-12, 2.3.2.1, – “To calculate water available from crop shifting, agencies would estimate what would have happened absent a transfer using an average water use over a consecutive five-year baseline period.” The proposed project and the EIS/R analysis fail to provide any reasonable assurances that real water savings will occur to offset these proposed transfers..
- Pg 2-13, 2.3.2.2, - “Modeling analysis indicates that using hydrology from 1970-2003, transfers could occur in 12 of the 33 years.” The project description, analysis and range of permit conditions should be limited to the same type of water years used for the analysis.
- Pg 2-13, 2.3.2.2, - “Sellers that are not specifically listed in this document may be able to sell water to the buyers as long as: the water that is made available occurs in the same water

74

75

76

77

78

79

80

81

shed or ground water basin analyzed in this EIS/EIR,...” Unless included within the scope of this EIS/R this would lead to piece-mealing project impacts. Also, New Melones Reservoir and the Stanislaus River were not included in the Areas of Analysis so according to this declaration in the EIS/R, no water from this basin can be included in future water transfers under this project.

- Pg 2-14, Figure 2-4 – Water transferred from Merced Irrigation District would have to flow down the San Joaquin River and other channels prior to being diverted by the CVP or SWP pumps in the south Delta or ther diversions. The EIS/R analysis did not take into account the amount of that water lost in transit. Evaporative losses and losses to groundwater are likely significant. This type of water loss in the transfer process is also true of all of the other water transfers to varying degrees depending on locations, transit path and times of year. As a result of the flawed assumptions of the EIS/R analysis, the project proposes to divert much more water than would actually be saved and understates the reduction in available water supply for other needs and the related impacts. As a result of the project taking too much credit for the amount of water transferred, the project would actually result in a net deficit of water in the delta and tributaries rather than the neutral flow impact the project analysis claims in the EIS/R. The impacts were not adequately identified, characterized, evaluated, quantified, mitigated or disclosed in the EIS/R. The EIS/R is flawed in its water conveyance loss assumptions and therefore deficient in its analysis and disclosure and must be revised. Attached is a copy of the May 24,2013 letter from the USBR and DWR to Tom Howard attempting to justify the April 28,2013 violation of the D-1641 salinity objective at Emmaton. The letter highlights a dramatic increase in overall rates of depletion to reservoir releases which “was simply not anticipated by project operators and is extreme from a historical perspective”. The analysis for the EIS/R is based on the same project operator modeling as was used in the flawed 2013 project operations. Although diversions for rice cultivation were cited the impact of water transfers, depletions of streamflow due to groundwater pumping and interception of accretions to streamflow in the dry year are likely. The models used for the analysis should be subjected to peer review corrections made and the analysis revised accordingly.
- Pg 2-16, Table 2-5 – FWS OCAP BO pg 229, p1, “Although transfers can occur at any time of year, the exports for transfers described in this assessment would occur only in the months July-September.” The analysis conducted in the FWS OCAP BO only addresses water transfers from July through September. Water transfers at any other time of year are not covered in the FWS OCAP BO, so the proposed project transfers in April – June are not covered under the current FWS OCAP Biological Opinion and are therefore not covered under the current CVP/SWP incidental take permits. Water transfers for any months outside of July – September must require additional ESA consultation with FWS.
- Pg 2-16, Table 2-5 - The reason that the water transfers covered under the FWS OCAP BO only covered July – September is that “Delta smelt are rarely present in the Delta in these months, so no increase in salvage due to water transfers during these months is anticipated, but as

81

82

83

84

described above, these transfers might affect delta smelt prey availability.” (FWS OCAP BO pg 229, p1). So water transfers that occur outside of those months, such as the April – June transfers in the proposed project, would result in take as smelt would be present at the pumps. The transfer impacts analyzed and approved in the FWS OACP BO specifically do not include the impacts that would occur from transfers during these other months. The Proposed Project and alternative must be revised to omit the April – June transfers or the project must seek ESA consultation with FWS for a Biological Opinion and incidental take permits that covers the impacts to delta smelt that would occur with water transfers in those months

- Pg 2-18, 2.3.2.3, - “Delta conveyance capacity would be available when conditions for sensitive species are acceptable to NOAA Fisheries and USFWS, typically from July through September, but groundwater substitution and cropland idling/crop shifting transfers would be available from April through September.” If the south delta pumps of the CVP or SWP are used in the April through June water transfers, regardless of the source or type of water credit being taken as the justification for the transfer, they will result in additional levels of ESA species take that was not covered under the FWS OCAP BO and therefore would require a new ESA consultation with FWS in order to occur. Appropriate environmental analysis for any changes would be required and should be a part of the EIS/R.
- Pg 2-18, 2.3.2.3, - “Reclamation would only consider storing water for transfers if it would not affect releases for temperature, or if it could be “backed up” into another reservoir (by reducing releases from that reservoir). Backing up water may be possible if the Delta is in balanced conditions and instream standards are met. The decision to back up transfer water would be made on a case-by-case basis, but storage is analyzed in this EIS/EIR so that the analysis is complete in the event Reclamation determines that storage is possible in a specific year.” Backing up transfers “into another reservoir by reducing releases from that reservoir” results in complex and significant fisheries impacts from water being released in one tributary at one time vs. a different tributary at a later time. In order for the permits based on this EIS/R to cover this proposed mode of operation of the proposed project, the analysis conducted - in this EIS/R must cover the full range of operations proposed to be covered by this document and implemented by the project. The EIS/R claims an analysis of storing water in Shasta was conducted. Analyses for other affected reservoirs must also be conducted.
- Pg 2-18, 2.3.2.3, - “Sacramento River sellers and buyers would generally prefer water transfer options that are more flexible, such as starting groundwater substitution pumping when Delta pumping capacity for transfers is available.” The analysis is inadequate to include the broad range of impacts associated with such flexibility.
- Pg 2-18, 2.3.2.3, - “Proposed sellers divert water from various locations along the Sacramento River or the Sutter Bypass.” The interrelationship of ground and surface water in the seller areas is obvious and difficult to analyze and monitor. After the fact monitoring does not avoid the impact. The groundwater substitution alternative should be rejected.

84

85

86

87

88

- Pg 2-22, 2.3.2.3, - “The Canal experienced substantial losses during conveyance to vegetation along the Canal system. The conservation project replaced the Canal with a pipeline and reduced associated losses to vegetation, thereby creating water for transfers.” Reducing vegetation is a critical factor in meaningful water savings., The EIS/R failed to identify, characterize, evaluate, quantify, mitigate or disclose any special status plants, fish or animal species that will be affected by the removal of this water source at the current leaks. Leaks could result in habitat supporting wetland plant communities and associated species. The project failed to mitigate for the wetland habitat that will be destroyed from fixing these leaks. Water from these leaks also would have contributed to adjacent stream flows which provide habitat for yellow and red legged frog, tiger salamander, and steelhead. In addition to the ESA species consultation with the fisheries and wildlife agencies for this action, the project also will need streambed alteration agreements, wetlands alteration, etc. from DFG, USACE and others.
- Pg 2-22, 2.3.2.3, - “Cordua ID would transfer water made available through groundwater substitution actions. This transfer would increase flows on the Yuba River downstream of Cordua ID’s point of diversion (absent the transfer) during the transfer period.” Groundwater and surface water interact. Groundwater wells, especially those physically located in proximity to a tributary, are hydraulically connected to the surface water. When a groundwater cone of depression intersects groundwater maintained by tributary surface flows, the cone of depression increases the rate of loss of surface flows to groundwater and bank recharge. In order to determine the actual increase in surface flows from the foregone diversion of surface water in favor of groundwater use, the location of each groundwater well and its situational relationship to surface water hydraulics must be analyzed. Irrigation district well fields tend to be in locations that are near their surface water diversion locations because the infrastructure to convey the surface water was there first and is required in order to deliver the pumped groundwater. This proximity of irrigation well fields being in proximity to irrigation surface water diversions was well documented in the Sacramento Valley Regional Water Plan “Phase 8” environmental document. This comment and criticism of the incompleteness of the EIS/R analysis of groundwater substitution impacts on surface water flows applies to all of the proposed groundwater substitutions included in the proposed project and alternatives. This deficiency and undisclosed impacts must be corrected in the revised EIS/R. Similarly the overall lowering of the groundwater even from pumping long distances from the rivers and streams will increase losses from the surface flow.
- Pg 2-26, Figure 2-8 – “Water could flow down the Merced River into the San Joaquin River and be diverted through existing facilities within Banta Carbona ID, West Stanislaus ID, or Patterson ID (see Figure 2-8). “ The NMFS and FWS OCAP BO analysis does not address this type of operation or these diversion locations for these purposes so the incidental take permits based on those BOs do not cover these operations..
- Pg 2-29, 2.3.2.4 – A number of assurances are missing from this list.

89

90

91

92

- There must be assurances that the project changes in relative flows and water temperatures for all tributaries affected by earlier or later releases and increased or decreased tributary flows do not adversely affect migratory fish. Changes in flow proportions or relative water temperatures at a tributary confluence can increase salmonid straying. Straying causes increased competition for holding and spawning habitat and associated prespawn mortality and reduction of fecundity; redd superimposition and associated egg mortality and genetic introgression result in a loss of productivity and reductions in the genetic integrity and diversity of the species.
- There must be an environmental commitment to use the stored water to protect water quality to be compliant with all water quality standards prior to any water transfer water being delivered. DWR and Reclamation routinely deliver SWP and CVP water while concurrently violating water quality requirements, including adverse modification of critical habitat for ESA listed species, e.g. dissolved oxygen deficiency in delta smelt critical habitat. This water transfer operation must not be allowed to deliver any water unless all water quality requirements are met and in the event that current water quality requirements are not being met by the CVP/SWP regular operations, this transfer water must be used for these water quality protection purposes first, before transfer water can be delivered.
- Since Reclamation's requirement to comply with the CVPIA is a requisite for their approval of water transfers for the project, the project should include the CVPIA 3405 (a) limitation which provides water transfers cannot "adversely affect water supplies for fish and wildlife purposes" as an environmental commitment.
- Pg 2-29, 2.3.2.4, – "In groundwater basins where sellers are in the same groundwater subbasin as protected aquatic habitats, such as giant garter snake preserves and conservation banks, groundwater substitution will be allowed as part of the long term water transfers if the seller can demonstrate that any impacts to water resources needed for special-status species protection have been addressed. In these areas, sellers will be required to address these impacts as part of their mitigation plan." There are no sub-basins in the proposed seller areas that do not contain protected aquatic habitats. This commitment must be expanded to include all protected habitats that may be affected by the water transfers. Not all special status species are in aquatic habitat. As a very real example of a proposed project impact, the repair of the pipeline as a conservation action will impair habitat for red and or yellow legged frog. A protected aquatic habitat not only includes preserves or conservation banks, but also critical habitat as designated by the ESA. There are no seller area sub-basins that do not have any ESA designated critical habitat so all of the sellers must address these impacts as part of their mitigation plan. These mitigation plans must be part of and disclosed in this EIS/R unless these will be addressed in a separate EIS/R prepared by the sellers as part of their ESA consultation process. To avoid piecemealing the analyses should be included in this document.
- Pg 2-29, 2.3.2.4– "Carriage water (a portion of the transfer that is not diverted in the Delta and becomes Delta outflow) will be used to maintain water quality in the Delta." The

92

93

94

analyses must include a defensible calculation of the quantity of the transferred water that actually reaches the delta to contribute to transfers and delta water quality. There are surface water evaporation losses, and loss to groundwater percolation and interception of accretions that must be accounted for that the EIS/R analysis has overlooked. Each potential water conveyance route, with its associated loss rates for the time period of the water transfer must be accounted for in the EIS/R analysis. The EIS/R must be revised to address this material deficiency.

- Pg 2-29, 2.3.2.4, – “As part of the approval process for long-term water transfers, Reclamation will have access to the land to verify how the water transfer is being made available and to verify that actions to protect the giant garter snake are being implemented.” Access to land does not assure compliance. Monitoring must be by a party without conflict, there must be a real enforcement mechanism and there must be funding for the enforcement effort.. Such assurances are not provided.

94

95



BUREAU OF RECLAMATION
 Central Valley Operation Office
 3310 El Camino Avenue, Suite 300
 Sacramento, California 95821



DEPARTMENT OF WATER RESOURCES
 Division of Operations and Maintenance
 3310 El Camino Avenue, Suite 300
 Sacramento, California 95821

MAY 24 2013

IN REPLY REFER TO:
 CVO-100
 WTR-4.10

Thomas Howard
 Executive Director
 State Water Resources Control Board
 1001 I Street
 Sacramento, California 95814

Subject: April 2013 Exceedence of Salinity Objectives at Emmaton

Dear Mr. Howard:

On April 28, 2013, the Bureau of Reclamation and the Department of Water Resources (collectively the Projects) exceeded the D-1641 salinity objective at Emmaton. Project operations staff notified State Water Resource Control Board (SWRCB) staff of the exceedence by conference call on April 29, 2013, and by e-mail notification to the SWRCB. This letter provides formal notification of the exceedence and background information relevant to the circumstances.

Background information leading to exceedence conditions:

The exceedence of the 14-day running average of 0.45 EC salinity objective at Emmaton for a Sacramento Valley Dry Year type was caused by the interaction of two conditions: low river flows on the lower Sacramento River system culminating at Freeport, and increasing tides during the period of April 21, 2013, through April 25, 2013. Tidal trends and fluctuations are conditions generally anticipated by Project operators as part of salinity objective compliance; however, the low flow conditions on the lower Sacramento River system in late April 2013 was not anticipated by Project operators and is the main factor of the exceedences that have occurred at Emmaton.

Precipitation patterns for water year 2013 have been a scenario of extremes. The months of November and December produced significant rainfall and project reservoir storage correspondingly increased without any significant flood control releases from major project reservoirs. The calendar year precipitation, however, has been dismal. The accumulation of rainfall since January 1 for the long record of the Northern Sierra 8-Station Precipitation Index is

Subject: April 2013 Exceedence of Salinity Objectives at Emmaton

2

approximately 8.8 inches. Currently, this value represents the driest calendar year period in the long precipitation record--even drier than the very dry single years of 1977 and 1924. Creek and small stream flows that enter the Sacramento River system below major reservoirs are running at historically very low levels in response to this long, dry precipitation period. (Attach 8SI plot)

Historically, the initial diversion for rice cultivation and ponding has generally occurred from late April to early May, depending on farmer cultivation and preparation practices and soil moisture conditions, to allow farmers to prepare their fields. Generally, project operators have observed this diversion to rice fields occur over several weeks from late April to early May, and have monitored river conditions and increased reservoir releases as rice cultivation diversion rates increased. It now appears that in 2013, due to the very dry hydrologic conditions since the first of the year, a very large portion of rice fields were cultivated and ready to begin their initial field flooding on a simultaneous schedule during the third week of April. This diversion to rice cultivation, although expected to occur, was unanticipated by Project operators for the sheer size and magnitude of simultaneous initial diversion for rice cultivation that actually occurred valley-wide.

Project operators responded to the increasing diversion rates during this period; by increasing reservoir releases in an attempt to catch up to the lower Sacramento River flow conditions. Figures 1 and 2 illustrate the Projects' reservoir release response to flow conditions in the lower Sacramento River during this period of unprecedented diversions. The first illustration shows Keswick's releases in response to the flow pattern at the Wilkins Slough river gage location. This section of the Sacramento River Basin is controlled exclusively with Shasta/Keswick reservoir releases with an approximate lagged travel time of 2.5 days between Keswick and Wilkins Slough. The second illustration indicates the reservoir releases in response to the flow pattern at the Verona river gage location. Verona flow is influenced by reservoir releases from Keswick Reservoir as well as Oroville Reservoir's releases to the Feather River. The approximate lagged travel time from Keswick is 3.5 days and just over one day from Oroville. Both illustrations show the dramatic increases from project reservoirs in response to low flow conditions observed along the lower Sacramento River. The dramatic increase in overall depletion rates experienced over a period of about ten days was simply not anticipated by project operators and is extreme from a historical perspective. Reservoir release rates of 11,000 cfs from Keswick Reservoir and 5,250 from Oroville Reservoir are more typical of late May than late April even in a dry condition. Folsom Reservoir releases were increased from 1,000 cfs to 1,250 cfs on April 25, 2013, to also contribute to lower Sacramento River flows.

The result of this unusual condition and timing is that Freeport flows entering the Delta were very low for a period of a week to ten days. (See Operational Report). At the same time, pulse flows were entering the Delta from the San Joaquin River at Vernalis as part of the annual pulse flow management from the San Joaquin River Basin. Due to the low flow conditions at Freeport, salinity conditions in the vicinity of Collinsville and Emmaton along the extreme lower Sacramento River and western Delta increased dramatically as tidal conditions increased. (See Operational Report). Project operators responded to the changing conditions by reducing scheduled exports that were anticipated to be near a 1:1 ratio with Vernalis flow in order to

Subject: April 2013 Exceedence of Salinity Objectives at Emmaton

3

maintain Delta outflow conditions necessary to meet X2 objectives at Collinsville. Without adequate flows at Freeport to repel salinity conditions in the lower Sacramento River, salinity levels near Emmaton inevitably exceeded the dry year objective of the maximum 14-day running average of mean at 0.45 salinity. Project reservoir releases stabilized Freeport flows at greater than 10,000 cfs beginning April 28, 2013, and averaged above this rate until compliance of the 14-day 0.45 EC objective at Emmaton was re-established on May 19.

Challenges facing project operations for the remainder of year:

By D-1641 criteria, water year 2013 is classified as a "Dry" year as published in the last Bulletin 120 update for May 1st hydrologic conditions. As previously mentioned, water year 2013 has been a year of extremes with generally wet conditions in November and December and retention of storage in upstream reservoirs, followed by extreme and possibly record dry precipitation conditions since January 1. This pattern of hydrologic conditions will very likely bring challenges for the remainder of this water year. Reservoir storage in Shasta and Oroville is in reasonably good shape, but will be relied upon heavily under adverse hydrologic conditions to balance the goals of Sacramento Valley diversion/depletion, Delta objectives, water supply delivery, and coldwater management. Folsom Reservoir management will be challenged by the overall availability of water and limited coldwater availability. The hydrologic conditions of 2013 and the early advent of significant depletion rates in the Sacramento Valley may indicate that historic high levels of Sacramento Valley depletions are likely during this year's irrigation season. (Projecting seasonal Sacramento Valley depletions, as compared to projecting full natural river flows in Bulletin 120, could be a difficult extrapolation from historic values, and uncertainty in depletion values is always a challenge to project operations.)

If you have any questions or would like more information regarding this notification, please contact Mr. Paul Fujitani of Reclamation at 916-979-2197 or Mr. John Leahigh at 916-574-2722.

Sincerely,

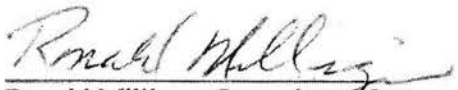

Ronald Milligan, Operations Manager
Central Valley Operations Office
U.S. Bureau of Reclamation

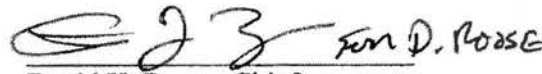

David H. Roose, Chief
SWP Operations Control Office
Department of Water Resources

Attachment -2

cc: See next page.

Subject: April 2013 Exceedence of Salinity Objectives at Emmaton

4

cc: Mr. John Herrick, Esq.

South Delta Water Agency
4255 Pacific Avenue, Suite 2
Stockton, California 95207

Clifford W. Schulz

Kronick, Moskovitz, Tiedemann & Girard
400 Capitol Mall, Suite 2700
Sacramento, California 95814

Mr. Craig M. Wilson, Delta Watermaster
State Water Resources Control Board
1001 I Street
Sacramento, California 95812

Carl Wilcox

California Department of Fish and Wildlife
1416 9th Street
Sacramento, California 95814

Ms. Christine Rico

Office of the Delta Watermaster
State Water Resources Control Board
1001 I Street
Sacramento, California 95812

Tim O'Laughlin

O'Laughlin and Paris LLP
117 Meyers Street, Suite 110
Chico, California 95928

Ms. Amy L. Aufdemberge
Assistant Regional Solicitor
Room E-1712
2800 Cottage Way
Sacramento, California 95825

Jon D. Rubin

San Luis-Delta Mendota Water Authority
1415 L Street, Suite 800
Sacramento, California 95814

Mr. Dante John Nomellini, Esq.
Nomellini, Grilli and McDaniel
Post Office Box 1461
Stockton, California 95201

Daniel Sodergren, City Attorney
City of Tracy
333 Civic Center Plaza
Tracy, California 95376

Mr. Carl P. A. Nelson
Bold, Polisner, Maddow,
Nelson and Judson
500 Ygnacio Valley Road, Suite 325
Walnut Creek, California 94596-3840

Patricia D. Fernandez

Division of Water Rights
1001 I Street, 14th Floor
Sacramento, California 95814

Thomas J. Shephard, Sr.
Post Office Box 20
Stockton, California 95201

Carolee Krieger

808 Romero Canyon Road
Santa Barbara, California 93108

Michael Jackson
Post Office Box 207
429 West Main Street
Quincy, California 95971
(w/encl to each)

FIGURE 1

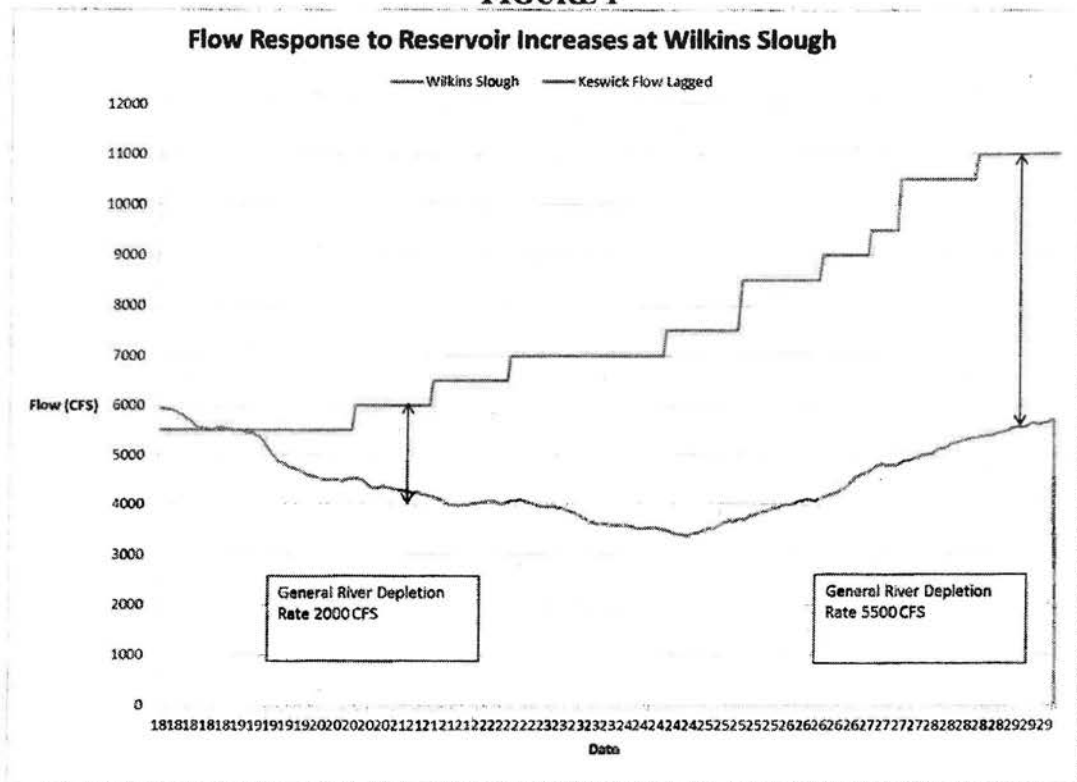
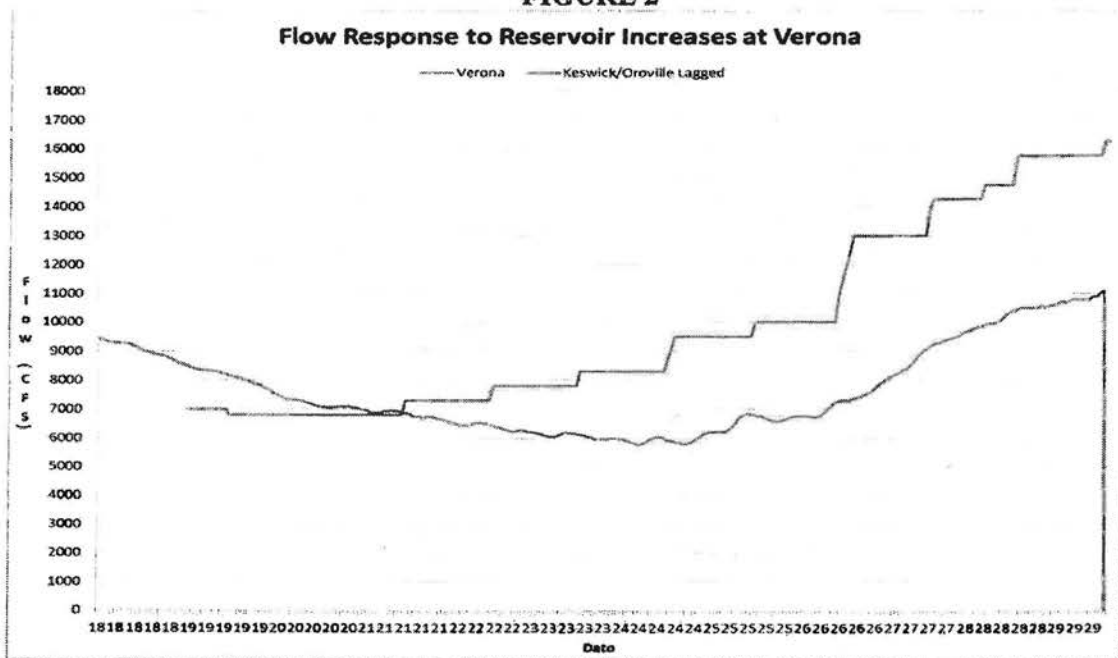
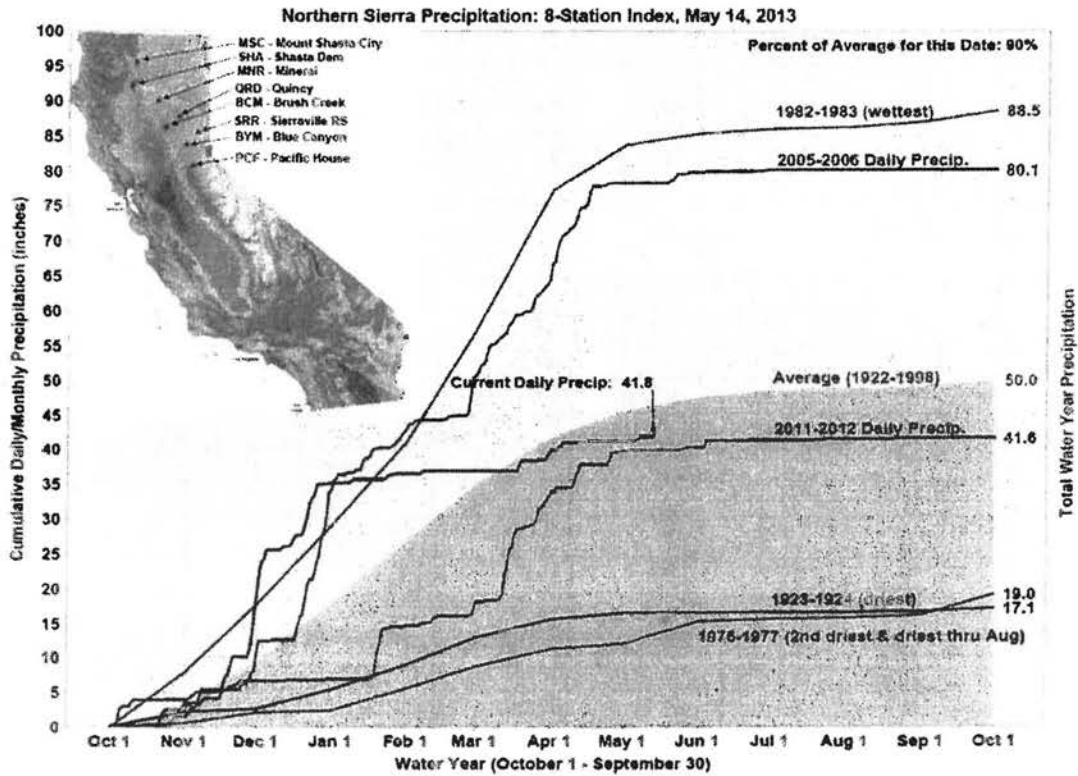

FIGURE 2



8SRI PLOT



Extreme Calendar Year Sac Valley Precipitation Conditions

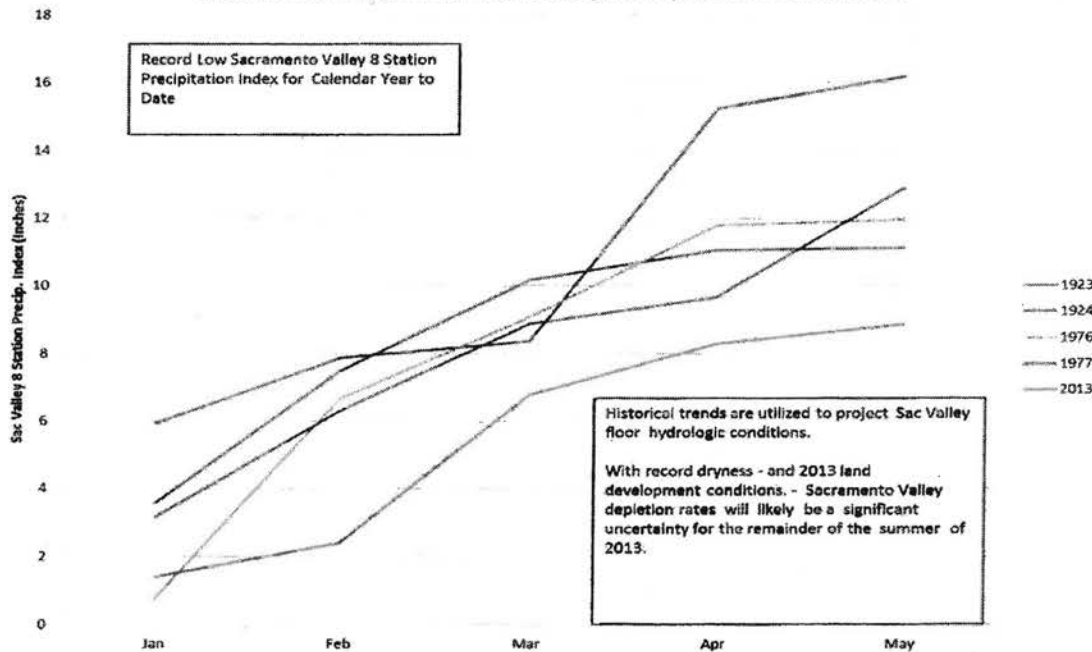

State of California - Department of Water Resources - Division of Operations & Maintenance - Operations Control Office

Compliance Standardsfor the Sacramento - San Joaquin Delta and Suisun Marsh
Sunday, May 19, 2013

Criteria	Standard	Status
Flow/Operational		
% of inflow diverted	35 %	11 %
Habitat Protection, X2 / Flow		
* 2days as carryover from April	1 days at Chipps Island	3 days
	31 days at Collinsville	19 days
Water Quality		
Days @ CCWD PP#1 w/ chlorides <= 150 mg/l	165 days	139 days
Export Areas for SWP, CVP, CCWD, et al	<= 250 mg/l Cl	42 mg/l
14dm EC at Emmaton	<= 0.45 mS/cm	0.44 mS/cm
14dm EC at Jersey Point	<= 0.45 mS/cm	0.34 mS/cm
Maximum 30 day running average of mean daily EC at:		
Vernalis	<=0.7 mS/cm	0.3 mS/cm
Brandt Bridge	<= 0.7 mS/cm	0.3 mS/cm
Old River Near Tracy	<=0.7 mS/cm	0.4 mS/cm
Old River Near Middle River	<=0.7 mS/cm	mS/cm
SUISUN MARSH:		
Suisun Marsh Salinity Control Gates :	1 Open / 0 Closed / 2 Full Tide Open	
Flashboard Status :	In	
Boat Lock Status :	Open	

California Hydrologic Conditions: (California Cooperative Snow Surveys Forecast, May 1, 2013)

Previous Month's Index (8RI for April.): 2.023 MAF

Water Year Type: Dry

Sacramento valley water year type index (40/30/30) @ 50%:5.8 MAF (Dry)

San Joaquin valley water year type index (60/20/20) @ 75%: 1.6 MAF (Critical)

Electrical Conductivity (EC) in millisiemens per Centimeter.

Chlorides (Cl) in milligrams per liter

mht - mean high tides

md - mean daily

14 dm - fourteen day running mean

28 dm - twenty-eight day running mean

NR - No Record

NC - Average not computed due to insufficient data.

BR : Below Rating

e - estimated value

Montezuma Slough Gate Operation:

Number of gates operating at either

Open, Closed, or Full Tide Open

Flashboard Status : In, Out, or Modified In

Boat Lock Status : Open or Closed

Coordinated Operation Agreement Delta Status:

c = excess Delta conditions

b = balanced Delta cond. w/ no storage withdrawal

s = balanced Delta cond. w/ storage withdrawal

Excess Delta conditions with restrictions:

f = fish concerns

r = E/I ratio concerns

* NDOI, Rio Vista & Vernalis Flows:

- Monthly average is progressive daily mean.

- 7 day average is progressive daily mean for the first six days of the month.

State of California - Department of Water Resources - Division of Operations & Maintenance - Operations Control Office

Delta Water Quality Conditions

Date	Antioch Tides		Net Delta Outflow Index cfs	Martinez mdEC	Port Chicago		Mallard mdEC	Chippis Island		Collinsville	
	High	Half			mdEC	14dm		mdEC	14dm	mdEC	14dm
04/20/2013	4.93	3.50	8,211	18.80	11.88	7.15	4.52	3.99	1.64	1.65	0.55
04/21/2013	5.12	3.57	7,471	21.29	13.71	7.53	6.22	5.68	1.90	2.35	0.68
04/22/2013	5.33	3.66	7,059	22.73	15.38	8.08	6.75	6.22	2.20	3.03	0.85
04/23/2013	5.73	3.88	6,849	24.39	15.82	8.80	7.88	7.37	2.65	4.18	1.12
04/24/2013	6.07	4.19	6,605	25.78	18.18	9.65	9.84	9.43	3.23	5.31	1.47
04/25/2013	6.47	4.25	7,038	26.40	18.77	10.49	10.63	10.27	3.86	6.13	1.88
04/26/2013	6.32	4.08	7,896	25.52	17.32	11.21	9.19	8.74	4.38	5.33	2.22
04/27/2013	6.31	4.02	9,030	24.92	16.30	11.84	8.76	8.29	4.86	4.95	2.54
04/28/2013	6.36	4.08	10,396	24.58	15.35	12.44	8.30	7.81	5.31	4.66	2.84
04/29/2013	6.40	4.24	10,578	24.44	14.82	12.96	8.21	7.72	5.75	4.38	3.11
04/30/2013	6.24	4.15	10,798	23.98	13.59	13.56	7.92	7.42	6.21	4.37	3.40
05/01/2013	5.84	3.99	11,146	22.44	11.37	14.10	6.67	6.13	6.60	3.97	3.66
05/02/2013	5.30	3.75	11,614	21.84	12.15	14.52	6.15	5.61	6.93	2.99	3.85
05/03/2013	5.51	3.82	10,635	21.60	12.21	14.78	6.64	6.10	7.20	3.02	4.02
05/04/2013	6.13	4.17	9,908	22.78	12.84	14.84	7.67	7.16	7.42	3.97	4.19
05/05/2013	6.32	4.48	9,485	25.15	12.95	14.79	9.37	8.93	7.66	5.28	4.40
05/06/2013	6.15	4.19	9,388	24.14	11.38	14.50	8.18	7.69	7.76	4.51	4.50
05/07/2013	6.06	4.10	9,350	23.80	11.10	14.17	8.04	7.54	7.77	4.44	4.52
05/08/2013	6.01	4.07	9,129	24.07	10.98	13.65	8.21	7.71	7.65	4.37	4.46
05/09/2013	6.05	4.08	9,695	23.57	9.40	12.98	7.95	7.45	7.45	4.07	4.31
05/10/2013	6.06	4.08	10,994	22.85	8.69	12.37	7.50	6.98	7.32	3.91	4.21
05/11/2013	6.04	4.03	11,743	21.76	7.75	11.76	6.63	6.09	7.17	3.39	4.10
05/12/2013	5.98	4.06	11,861	20.78	7.95	11.23	6.40	5.87	7.03	3.28	4.00
05/13/2013	5.94	4.12	11,402	21.10	7.48	10.70	6.19	5.65	6.88	3.12	3.91
05/14/2013	5.80	4.16	11,153	21.37	6.97	10.23	6.22	5.68	6.76	2.89	3.80
05/15/2013	5.72	4.15	10,114	21.13	5.60	9.82	6.14	5.60	6.72	2.74	3.71
05/16/2013	5.26	4.02	9,550	21.54	2.97	9.16	5.75	5.21	6.89	2.87	3.70
05/17/2013	5.18	3.95	8,987	21.04	2.33	8.46	5.39	4.85	6.60	1.99	3.63
05/18/2013	5.07	3.63	9,399	18.61	2.09	7.69	4.55	4.02	6.38	1.69	3.47
05/19/2013	5.27	3.48	9,727	18.03	1.99	6.91	4.14	3.62	6.00	1.52	3.20

Antioch Tides measured in feet above mean sea level.
Net Delta Outflow Index calculated from equation as specified in D-1641, revised June 1995.
Chippis Island EC calculated from measurements recorded at Mallard Slough.
Electrical Conductivity (EC) units: milliSiemens per Centimeter
md : mean daily
14dm : fourteen day running mean
NR : No Record
NC : Average not computed due to insufficient data
BR : Below Rating
e - estimated value

State of California - Department of Water Resources - Division of Operations & Maintenance - Operations Control Office

Delta Water Quality Conditions

Date	Antioch		Jersey Point		Emmaton		Cache Slough	Good Year Slough	Sunrise Club	Volanti Slough	Beldon Landing	Collinsville
	mdEC	14mdEC	mdEC	14mdEC	mdEC	14mdEC	mdEC	mhtEC	mhtEC	mhtEC	mhtEC	mhtEC
04/20/2013	0.39	0.42	0.23	0.25	0.20	0.20	0.39	5.83	5.06	5.62	5.55	2.04
04/21/2013	0.61	0.42	0.24	0.25	0.22	0.20	0.40	5.92	5.40	6.19	5.60	3.56
04/22/2013	0.87	0.44	0.24	0.25	0.25	0.20	0.42	6.13	5.97	6.77	5.93	4.39
04/23/2013	1.16	0.49	0.25	0.25	0.29	0.21	0.42	6.94	7.31	8.39	7.40	5.37
04/24/2013	1.93	0.60	0.30	0.25	0.71	0.25	0.42	8.71	8.59	10.03	9.00	6.92
04/25/2013	2.36	0.74	0.36	0.26	1.28	0.32	0.43	9.73	8.79	10.32	9.24	7.42
04/26/2013	1.91	0.85	0.33	0.26	1.06	0.39	0.43	10.74	9.36	10.77	9.23	6.54
04/27/2013	1.87	0.95	0.34	0.27	1.00	0.44	0.42	11.60	9.71	11.16	9.59	5.86
04/28/2013	1.93	1.06	0.35	0.27	0.89	0.49	0.43	11.74	9.83	10.73	10.02	5.61
04/29/2013	2.04	1.17	0.36	0.28	0.75	0.53	0.45	11.84	10.00	11.33	10.34	5.73
04/30/2013	1.90	1.28	0.37	0.29	0.64	0.56	0.46	11.91	9.92	11.63	10.50	5.40
05/01/2013	1.33	1.35	0.35	0.30	0.35	0.57	0.51	11.90	9.76	11.44	10.86	4.69
05/02/2013	1.28	1.42	0.32	0.31	0.35	0.58	0.46	11.85	9.95	11.16	10.66	3.85
05/03/2013	1.29	1.49	0.33	0.31	0.38	0.60	0.46	11.87	9.85	11.30	9.99	4.36
05/04/2013	1.55	1.57	0.36	0.32	0.44	0.61	0.48	11.74	10.13	10.74	9.79	5.88
05/05/2013	2.21	1.69	0.44	0.34	0.76	0.65	0.42	11.59	9.85	10.94	9.73	6.92
05/06/2013	1.87	1.76	0.39	0.35	0.67	0.68	0.42	11.57	9.68	10.58	8.64	5.54
05/07/2013	1.71	1.80	0.37	0.36	0.62	0.71	0.43	11.61	9.25	9.83	7.57	5.72
05/08/2013	1.66	1.78	0.36	0.36	0.63	0.70	0.45	11.64	8.67	9.42	7.11	5.77
05/09/2013	1.63	1.73	0.36	0.36	0.61	0.65	0.48	11.79	8.13	9.21	6.63	5.27
05/10/2013	1.48	1.70	0.35	0.36	0.57	0.62	0.50	11.99	7.76	8.60	6.49	5.24
05/11/2013	1.32	1.66	0.34	0.36	0.46	0.58	0.48	12.11	7.49	8.22	6.05	4.24
05/12/2013	1.32	1.61	0.34	0.36	0.41	0.54	0.45	11.82	7.10	7.63	5.50	4.49
05/13/2013	1.18	1.55	0.34	0.36	0.37	0.52	0.45	11.36	6.59	7.07	4.94	3.93
05/14/2013	1.12	1.50	0.34	0.36	0.34	0.50	0.43	11.33	6.13	6.45	4.24	4.30
05/15/2013	1.11	1.48	0.33	0.35	0.37	0.50	0.42	11.16	5.72	5.97	3.88	3.56
05/16/2013	1.03	1.46	0.32	0.35	0.32	0.50	0.40	10.60	5.18	5.67	3.68	
05/17/2013	0.91	1.44	0.31	0.35	0.29	0.49	NR	10.25	5.10	5.62	3.53	3.14
05/18/2013	0.74	1.38	0.30	0.35	0.25	0.48	NR	10.12	5.04	5.56	3.31	2.43
05/19/2013	0.70	1.27	0.29	0.34	0.23	0.44	NR	9.95	4.98	5.51	2.97	2.33

Electrical Conductivity (EC) units: milliSiemens per Centimeter

Chloride (Cl) units: milligrams per liter

mht : mean high tides

md : mean daily

NR : No Record

NC : Average not computed due to insufficient data

BR : Below Rating

e : estimated value

State of California - Department of Water Resources - Division of Operations & Maintenance - Operations Control Office

Delta Water Quality Conditions

Date	Electrical Conductivity (EC) units: milliSiemens per Centimeter							Tracy Pumping Plant			Delta Status
	Bethel Island mdEC	Farrar Park mdEC	Holland Tract mdEC	Bacon Island mdEC	Contra Costa mdEC	Clifton Court mdEC	Pumping Plant mdEC	Antioch mdCl	Bacon Island mdCl	Contra Costa mdCl	
04/20/2013	0.25	0.29	0.26	0.27	0.34	0.57	0.75	54	33	37	f
04/21/2013	0.25	0.29	0.25	0.27	0.32	0.51	0.68	124	32	38	f
04/22/2013	0.24	0.29	0.25	0.27	0.33	0.46	0.60	206	32	37	f
04/23/2013	0.24	0.29	0.25	0.27	0.33	0.43	0.50	298	31	37	f
04/24/2013	0.25	0.28	0.25	0.27	0.32	0.40	0.49	545	31	37	f
04/25/2013	0.26	0.27	0.25	0.26	0.32	0.38	0.42	683	31	36	s
04/26/2013	0.26	0.29	0.26	0.27	0.31	0.35	0.43	537	32	36	s
04/27/2013	0.25	0.29	0.26	0.28	0.32	0.32	0.40	524	34	36	s
04/28/2013	0.26	0.29	0.26	0.28	0.32	0.32	0.35	544	35	36	s
04/29/2013	0.26	0.30	0.26	0.28	0.29	0.31	0.32	581	35	36	s
04/30/2013	0.26	0.30	0.26	0.28	0.31	0.34	0.33	535	34	36	s
05/01/2013	0.27	0.29	0.26	0.27	0.30	0.32	0.33	352	32	36	s
05/02/2013	0.28	0.29	0.21	0.27	0.31	0.33	0.32	337	32	34	s
05/03/2013	0.28	0.29	0.23	0.27	0.31	0.33	0.31	341	32	35	s
05/04/2013	0.28	0.30	0.27	0.27	0.30	0.32	0.31	424	32	35 e	s
05/05/2013	0.29	0.31	0.28	0.28	0.29	0.30	0.28	635	34	35 e	s
05/06/2013	0.29	0.31	0.28	0.28	0.29	0.25	0.28	525	35	33	s
05/07/2013	0.29	0.32	0.28	0.29	0.29	0.24	NR	475	37	33	s
05/08/2013	0.30	0.33	0.29	0.29	0.28	0.24	NR	458	38	33	s
05/09/2013	0.30	0.33	0.29	0.30	0.30	0.25	NR	448	40	34	s
05/10/2013	0.31	0.34	0.30	0.30	0.30	0.26	NR	400	41	35	s
05/11/2013	0.31	0.33	0.30	0.31	0.29	0.28	NR	351	42	35 e	s
05/12/2013	0.31	0.34	0.30	0.31	0.31	0.29	NR	351	43	35 e	s
05/13/2013	0.31	0.33	0.31	0.32	0.32	0.31	NR	307	44	37	s
05/14/2013	0.31	0.33	0.31	0.32	0.32	0.30	NR	288	45	39	s
05/15/2013	0.31	0.34	0.31	0.32	0.32	0.32	NR	283	45	36	s
05/16/2013	0.31	0.34	0.31	0.32	NR	0.34	NR	257	45	40	s
05/17/2013	0.31	0.34	0.31	0.32	NR	0.35	NR	220	46	42	s
05/18/2013	0.31	0.34	0.31	0.33	NR	0.36	NR	166	47	42 e	s
05/19/2013	0.31	0.34	0.31	0.33	NR	0.39	NR	151	47	42 e	s

Electrical Conductivity (EC) units: milliSiemens per Centimeter
 Chloride (Cl) units: milligrams per liter
 md : mean daily
 NR : No Record
 NC : Average not computed due to insufficient data
 BR : Below Rating
 e : estimated value
 Antioch and Bacon Island mdCl are calculated from the respective mdEC values.

Coordinated Operation Agreement Delta Status:
 c = excess Delta conditions
 b = balanced Delta cond. w/ no storage withdrawal
 s = balanced Delta cond. w/ storage withdrawal
 Excess Delta conditions with restrictions:
 f = fish concerns
 r = E/I ratio concerns

State of California - Department of Water Resources - Division of Operations & Maintenance - Operations Control Office

Delta Water Quality Conditions

South Delta Stations

Date	Vernalis		Brandt Bridge		Old River Near Tracy		Old River Near Middle River	
	md EC	30 day avg	md EC	30 day avg	md EC	30 day avg	md EC	30 day avg
04/20/2013	0.39	0.79	0.52	0.88	0.90	1.10	0.40	0.87
04/21/2013	0.30	0.77	0.41	0.86	0.76	1.09	0.43	0.85
04/22/2013	0.30	0.75	0.42	0.84	0.64	1.08	0.33	0.84
04/23/2013	0.27	0.72	0.32	0.82	0.62	1.07	0.31	0.81
04/24/2013	0.25	0.70	0.30	0.80	0.47	1.05	0.26	0.79
04/25/2013	0.24	0.68	0.24	0.78	0.41	1.02	0.22	0.77
04/26/2013	0.24	0.65	0.22	0.76	0.34	1.00	0.21	0.74
04/27/2013	0.23	0.62	0.21	0.73	0.38	0.97	0.21	0.72
04/28/2013	0.23	0.60	0.21	0.71	0.38	0.94	0.21	0.69
04/29/2013	0.22	0.58	0.21	0.68	0.37	0.91	0.20	0.66
04/30/2013	0.22	0.56	0.20	0.66	0.35	0.88	0.20	0.64
05/01/2013	0.21	0.54	0.20	0.64	0.32	0.85	0.20	0.61
05/02/2013	0.21	0.52	0.20	0.61	0.36	0.82	0.19	0.59
05/03/2013	0.20	0.50	0.20	0.59	0.36	0.80	0.20	0.57
05/04/2013	0.19	0.47	0.19	0.57	0.31	0.77	0.18	0.55
05/05/2013	0.18	0.45	0.18	0.55	0.27	0.74	0.17	0.52
05/06/2013	0.19	0.43	0.17	0.52	0.25	0.72	0.17	0.50
05/07/2013	0.20	0.41	0.18	0.50	0.28	0.69	0.18	0.48
05/08/2013	0.20	0.39	0.20	0.48	0.31	0.67	0.20	0.45
05/09/2013	0.22	0.37	0.20	0.45	0.30	0.64	0.21	0.43
05/10/2013	0.22	0.35	0.22	0.43	0.29	0.62	NR	NC
05/11/2013	0.21	0.33	0.23	0.41	0.29	0.59	NR	NC
05/12/2013	0.21	0.31	0.22	0.38	0.29	0.56	NR	NC
05/13/2013	0.22	0.29	0.22	0.36	0.30	0.53	0.23	NC
05/14/2013	0.26	0.28	0.24	0.34	0.30	0.50	0.25	NC
05/15/2013	0.33	0.27	0.27	0.32	0.31	0.48	0.29	NC
05/16/2013	0.38	0.26	0.32	0.30	0.36	0.45	0.37	NC
05/17/2013	0.40	0.26	0.37	0.28	0.43	0.43	0.44	NC
05/18/2013	0.44	0.26	0.44	0.27	0.47	0.42	0.47	NC
05/19/2013	0.48	0.26	0.47	0.27	0.54	0.40	0.51	NC

Electrical Conductivity (EC) units: milliSiemens per Centimeter

md : mean daily

NR : No Record

NC : Average not computed due to insufficient data

BR : Below Rating

e : estimated value

State of California - Department of Water Resources - Division of Operations & Maintenance - Operations Control Office

Delta Hydrology Conditions

Date	Sacramento River at Freeport + SRWTP cfs	Yolo Bypass cfs	East Side Streams cfs	San Joaquin River at Vernalis cfs	Rainfall inches	Clifton Court Forebay Intake cfs	Tracy Pumping Plant cfs	CCWD Pumping Plants cfs	Barker Slough Pumping Plant cfs	BBID Diversion cfs
4/20/2013	8,441	395	591	2,334	0.00	1,193	807	25	56	0
4/21/2013	7,858	398	548	2,545	0.00	1,494	810	25	62	0
4/22/2013	7,645 e	410	519	2,678	0.00	1,694	810	25	62	200
4/23/2013	7,194	439	529	2,935	0.00	1,690	813	25	48	73
4/24/2013	6,360	496	559	3,414	0.00	1,695	821	26	72	72
4/25/2013	7,006	530	570	3,582	0.00	996	817	25	70	67
4/26/2013	8,078	529	542	3,675	0.00	991	815	25	65	53
4/27/2013	9,423	585	502	3,765	0.00	995	814	24	78	66
4/28/2013	10,870	584	509	3,893	0.00	963	815	24	77	0
4/29/2013	11,478	602	512	4,130	0.00	2,421	815	26	83	66
4/30/2013	12,147	616	500	4,064	0.00	2,998	817	27	83	0
5/1/2013	12,415	623	479	3,954	0.00	3,193	814	152	88	66
5/2/2013	11,495	629	463	3,952	0.00	494	3,155	178	94	63
5/3/2013	10,056	623	466	4,043	0.00	494	3,082	226	117	67
5/4/2013	9,028	660	478	4,176	0.00	1,492	1,353	240	96	0
5/5/2013	8,414	665	456	4,105	0.00	1,490	937	245	84	0
5/6/2013	8,445	648	445	3,970	0.00	993	982	245	91	159
5/7/2013	8,390	616	456	3,838	0.00	793	980	243	84	91
5/8/2013	9,212	557	479	3,689	0.00	792	979	243	84	77
5/9/2013	10,884	510	484	3,581	0.00	793	978	257	84	70
5/10/2013	11,824	486	468	3,549	0.00	999	978	261	98	72
5/11/2013	12,068	450	478	3,509	0.00	993	983	258	101	0
5/12/2013	11,480	448	479	3,439	0.00	993	982	260	109	0
5/13/2013	11,425	500	451	3,376	0.00	993	980	266	110	206
5/14/2013	10,886	553	416	2,828	0.00	993	980	252	99	76
5/15/2013	10,928	603	400	2,090	0.00	992	979	236	97	86
5/16/2013	10,499	579	410	1,878	0.00	993	863	207	92	84
5/17/2013	11,073	605	445	1,521	0.00	688	811	190	103	65
5/18/2013	11,534	643	439	1,423	0.00	689	808	185	112	0
5/19/2013	11,854	618	418	1,309	0.00	699	808	202	103	0

SRWTP : Sacramento Regional Water Treatment Plant effluent.

Yolo Bypass : combined measurements of Cache Creek at Rumsey and Freemont Weir.

East Side Streams : combined stream flows of Cosumnes River at Michigan Bar, Mokelumne River at Woodbridge, miscellaneous streams estimated from Dry Creek at Galt (discontinued since Dec. 1997), and Calaveras River based on releases from New Hogan Dam.

Rainfall : incremental daily precipitation measured at Stockton Fire Station #4.

CCWD Pumping Plants : combined pumping at the Old River, Rock Slough and Middle River Plants.

State of California - Department of Water Resources - Division of Operations & Maintenance - Operations Control Office

Delta Hydrology Conditions

Date	Banks Pumping Plant cfs	Delta Gross Channel Depletions cfs	Rio Vista Flow cfs	QWEST cfs	Net Delta Outflow Index cfs	Percent of Inflow Diverted		Delta Status
						3 day	14 day	
4/20/2013	1,161	1,900	7,029	1,372	8,211	13.3%	10.4%	f
4/21/2013	1,504	1,900	6,352	1,313	7,471	16.4%	12.6%	f
4/22/2013	1,504	1,900	5,850	1,404	7,059	18.7%	14.2%	f
4/23/2013	1,779	1,900	5,677	1,353	6,849	20.5%	15.7%	f
4/24/2013	1,504	1,950	5,301	1,512	6,805	21.3%	16.7%	f
4/25/2013	810	1,950	4,635	2,609	7,038	20.0%	16.0%	s
4/26/2013	895	1,950	5,229	2,868	7,896	17.7%	14.8%	s
4/27/2013	887	1,950	6,158	3,087	9,030	14.8%	13.4%	s
4/28/2013	985	2,000	7,366	3,247	10,396	13.6%	13.7%	s
4/29/2013	1,684	2,000	8,619	2,181	10,578	15.6%	17.3%	s
4/30/2013	2,348	2,000	9,164	1,856	10,798	18.7%	22.5%	s
5/1/2013	3,279	2,000	9,758	1,616	11,146	21.9%	27.7%	s
5/2/2013	1,123	2,000	9,998	1,850	11,614	22.0%	28.2%	s
5/3/2013	1,034	2,050	9,192	1,704	10,635	21.5%	26.9%	s
5/4/2013	1,654	2,100	7,925	2,226	9,908	20.2%	23.9%	s
5/5/2013	2,095	2,100	7,070	2,646	9,485	19.1%	20.8%	s
5/6/2013	596	2,100	6,543	3,083	9,388	16.4%	16.6%	s
5/7/2013	0	2,150	6,539	3,045	9,350	14.3%	13.7%	s
5/8/2013	0	2,150	6,459	2,905	9,129	12.8%	11.9%	s
5/9/2013	138	2,200	7,099	2,835	9,695	12.5%	11.5%	s
5/10/2013	1,101	2,200	8,501	2,745	10,994	12.4%	11.8%	s
5/11/2013	1,101	2,250	9,278	2,723	11,743	12.2%	12.2%	s
5/12/2013	1,101	2,300	9,440	2,691	11,861	12.1%	12.6%	s
5/13/2013	1,101	2,300	8,928	2,746	11,402	11.7%	12.3%	s
5/14/2013	1,015	2,350	8,918	2,498	11,153	11.7%	12.2%	s
5/15/2013	1,101	2,350	8,504	1,872	10,114	12.0%	12.2%	s
5/16/2013	930	2,400	8,577	1,233	9,550	12.5%	12.4%	s
5/17/2013	732	2,450	8,167	1,095	8,987	12.2%	11.6%	s
5/18/2013	732	2,450	8,690	992	9,399	11.5%	10.8%	s
5/19/2013	732	2,500	9,114	892	9,727	10.9%	10.2%	s

Delta Gross Channel Depletions from Dayflow Table 3.

Rio Vista Flow calculated from Dayflow equation.

QWEST calculated from Dayflow equation.

Net Delta Outflow Index calculated from equation as specified in D-1641, revised June 1995.

Coordinated Operation Agreement Delta Status:

c = excess Delta conditions

b = balanced Delta cond. w/ no storage withdrawal

s = balanced Delta cond. w/ storage withdrawal

Excess Delta conditions with restrictions:

f = fish concerns

r = E/I ratio concerns

- Pg 2-31, 2.3.2.5, – East Bay MUD and Contra Costa WD should have been lead agencies as this EIS/R document will inform them for their decision on if to approve this document and to participate in the water transfer program. 96
- Pg 2-31, 2.3.2.5, – “Transfers to East Bay MUD and Contra Costa WD are limited by available pumping capacity at the Freeport intake and Contra Costa WD’s Delta intakes...” Water diverted at Freeport does not traverse the delta and does not contribute to south delta water quality or net delta outflows. 97
- Pg 2-34, 2.3.2.7, – “Buyers and sellers may negotiate transfers that last one year or multiple years.” The project could result in some land being idled for 10 years straight. This could lead to land use designation changes fostering development or protected habitat. The possible long term impacts should be further analyzed. 98
- Pg 2-39, 2.5, – “While the alternatives would affect different resources in different ways, none of the alternatives are considered to be the environmentally superior alternative. There are no unavoidable significant impacts associated with the Proposed Action that would otherwise be avoided or substantially reduced by an alternative, and each of the alternatives has its own unique set of environmental impacts which, on balance, would be a “trade-off” of environmental impacts in selecting any one alternative over another.” A number of significant impacts have been ignored and missed by the EIS/R analysis. the Proposed Action (Alternative 2) is not the environmentally superior alternative. 2.5, provides “Alternative 4 would reduce effects to groundwater levels, quality, and land subsidence.” Any land subsidence from groundwater substitution is a significant impact. Alternative 2 includes groundwater substitution and land subsidence impacts, so alternative 4 is clearly environmentally superior. 99
- Pg 2-39, 2.5 – The project should have separated crop idling from crop switching in an alternative as they have very different impacts and operational requirements. Crop switch was proposed and screened as a separate conservation measure from crop idling. If crop switching were made a standalone alternative along with other conservation measures such as irrigation canal lining and leak repair, irrigation system water distribution uniformity and water efficiency improvements and irrigation scheduling water use efficiency improvements, there would have been an alternative which yielded real water for transfer, was flexible and immediate to implement. This combination of measures in an alternative would have yielded substantial water supplies with fewer environmental impacts of the other alternatives. 100
- Pg 2-40, Table 2-9, 3.2 – “Cropland idling transfers could result in increased deposition of sediment on water bodies.” Some soils carry contaminants with them. This sediment deposition degrades water quality and beneficial uses. Any degradation of beneficial uses is 101

- significant for compliance with the Central Valley Regional Water Quality Control Board Basin Plan.
- Pg 2-40, Table 2-9, 3.2 – “Cropland idling/shifting transfers could change the water quality constituents associated with leaching and runoff.” The EIS/R consistently lumps the description of effects of these two very different actions together. These are separate, mutually exclusive actions to implement on a piece of ground and they have very different impacts in type and magnitude. The EIS/R must separate the analysis of these two actions and disclose and mitigate their impacts separately. As an example, crop shifting would have very little erosional deposition in tributaries while crop idling may precipitate large and significant soil deposition and contamination to waterways.
 - Pg 2-40, Table 2-9, 3.2 – “Cropland idling/shifting transfers could change the quantity of organic carbon in waterways.” Again, the impacts of these two separate and different project actions have been lumped together to obscure the impacts of each – they are not the same.
 - Pg 2-40, Table 2-9, 3.3 – “Groundwater substitution transfers could cause a reduction in groundwater levels in the Seller Service Area.” and “Groundwater substitution transfers could cause subsidence in the Seller Service Area.” Both were determined by the EIS/R to be a significant impact. The mitigation proposed by the EIS/R is to monitor the groundwater levels and subsidence. Monitoring something does not mitigate the impact of a project, only positive action like having a specific decision threshold for ceasing groundwater pumping activities would be a mitigation. There also needs to be a mitigation plan if groundwater levels do not recover or subsidence occurs even after cessation of groundwater pumping.
 - Pg 2-45, Table 2-9, 3.9 – “Cropland idling water transfers could permanently or substantially decrease the amount of lands categorized as Prime Farmland, Farmland of Statewide Importance, or Unique Farmland under the FMMP.” The EIS/R identifies the alternative 4 impact as significant and alternative 2 as LTS. Although alternative 2 includes groundwater substitution, there is no description in the alternatives which prohibits just as much crop idling in alternative 2 as in alternative 4 so both impacts are significant. If alternative 4 results in 177,000 acres of land being fallowed and alternative 2, because it includes groundwater substitution idles only 100,000 acres, the impact of alternative 2 is still significant even though it is less than alternative 4.
 - Pg 2-45, Table 2-9, 3.9 – “Cropland idling water transfers could convert agricultural lands under the Williamson Act and other land resource programs to an incompatible use.” There is no support for the LTS impact call when 177,000 acres of crops could be idled and nothing in the project precludes the same land being idled for all 10 years of the program? 10 years of crop idling and using the property for non-agricultural purposes is in direct conflict with the requirements of the Williamson Act. As the Proposed Project and alternatives are defined, the maximum impact to Williamson Act lands is 177,000 acres of crop idling on the same land for 10 years. This is a significant impact that must be mitigated and disclosed.
 - Pg B-8, B.4.3.1.2 - “Transfer Operations and Priorities TOM uses an assumed priority for transfer mechanisms used to make water available under Project alternatives.” This assumption is a fundamental flaw in the analysis of the impacts of the project. The alternatives clearly say that the sellers can transfer up to a limit amount. The project does not define in what priority or sequence those different sources for water for transfer would be implemented under the project. Operational problems with reservoirs or differences in snowpack in different basins could alter the sequence of implementation of the water transfer sources. As an example, if alfalfa prices were to go to levels that were unprofitable, many growers would first offer to switch to another crop and sell that water to the program. Although there is some rationale provided for the assumption used, the project may very well not operate that way at all in reality. The project must not be approved for operations that deviate from the assumptions used in the project analysis of impacts, otherwise the project has been permitted for impacts that were never analyzed mitigated or disclosed.
 - Pg B-8, B.4.3.1.2, p1 - “TOM simulates the four transfer mechanisms in the following order:

101

102

103

104

105

106

107

108

- Groundwater substitution – for alternatives that include this mechanism
- Reservoir release
- Conserved water
- Crop idling – for alternatives that include this mechanism”

The TOM assumptions do not include crop shifting so the model assumptions were incomplete and incorrect to reflect the actions that were included in the alternatives.

- Pg B-9, Figure B-4 – The project is only using a 33 year period of record for hydrologic conditions. This truncated hydrologic period skews the impact analysis and fails to use the best available science of the readily available and industry standard utilized 83+ year period of record. The EIS/R must be revised using the best available science as NEPA and CEQA requires. 108
- Pg B-9, B.4.3.1.2, – “Groundwater substitution transfers from the Sacramento Valley have the potential to create changes in stream-aquifer interaction that affect other parts of the water delivery system.” Each tributary reach has unique surface and groundwater interactions. The EIS/R fails to disclose what the modeling assumptions were for the geographic distribution of the estimated groundwater transfers. If the groundwater is drawn from primarily adjacent to a single or limited set of tributaries then the groundwater surface water interactions and impacts would be more severe and focused. It appears the analysis assumed an even distribution of the estimated (with unsound rationale) amount of groundwater substitution across the whole north of Delta seller area. This error in modeling assumption causes the analysis to conclude much lower impacts that would occur within the range of operations the proposed project and alternatives. 109
- Pg B-11, B.4.3.1.2 – “Changes in Delta inflow affect the CVP and SWP differently based on system conditions at the time and COA accounting.” This is why we said in an earlier comment that the COA being out of date was a problem for this project that had to be addressed by updating the COA. 110
- Pg B-15, B.4.3.1.5, – “Annual volumes were assumed to be made available on a monthly pattern based on the ETAW of rice, the assumed crop to be idled.” This is a flawed assumption which leads to underestimating the impacts of the proposed project and alternatives. Rice has the highest ETAW at 3.3AF per acre of any of the crops proposed for idling. This assumption is in conflict with the reality of the program which would have a mix of idled crops with different and lower ETAW water consumption rates. This flawed analysis assumption will either lead to the project estimating that less number of acres will be fallowed to accomplish a given target amount of water for transfer or less water being made available for transfer with a given number of acres idled. Either way, the analysis assumption under-estimates the impacts of the project and the analysis must be revised and recirculated once this material analytical error is corrected. 111
- Pg B-16, B.4.3.1.5, p4 – “Crop idling transfers offer the least flexibility of all transfer mechanisms. The decision to enter into crop idling transfers is typically made in spring months when there is still considerable uncertainty in the water supply forecast and the ability to convey water through the Delta.” This is not true. In most years when water transfers are most desired are in years after the first year of a Dry or Critically Dry water year. In those cases when reservoir storage is down, although the exact amount of water allocation may not be announced until the spring, all of the buyers already know that they want to buy water. Each of the water transfer water sources suffer the same limitations on knowing the delta conditions ahead of time and their ability to convey water through the delta. This misperception on the part of the project in terms of the relative desirability of the water sources in the sequence in which water sources would be implemented in the project is 112
- 113

flawed. In order to be conservative in identifying the types and magnitude of impacts from the proposed project, the EIS/R should have analyzed the range of actions that it desired to be permitted, not an undefined, unjustified and flawed rationale for generally how the program may or may not be implemented. In order to correct these flawed assumptions and allow a full range of operations as proposed by the project, the analysis needs to do a sensitivity analysis of doing the maximum amount of each water transfer type and in combination with other types. Only then will the potential impacts of the project be disclosed and properly mitigated.

- Pg B-16, B.4.3.1.5, – “Crop idling transfers make water available on the fixed schedule illustrated in Figure B-10. Therefore, transfer water made available in May and June, a total of 37 percent of the annual volume, can be lost or not diverted...” Some rice is not planted until the first of June, so the potential transfer loss in those cases is only 22% rather than the 37% as claimed in the EIS/R.
- Pg B-17, B.4.3.1.6, – “Analysis of the baseline CalSim II simulation of CVP and SWP operations was performed to identify potential opportunities to store both groundwater substitution and crop idling transfer water made available from April through June in upstream CVP and SWP reservoirs.” Again, the analysis did not include the assumption of water transfer volumes from crop switching.
- Pg B-17, B.4.3.1.7, – “TOM simulates shifts in timing of Project water movement at SWP facilities by adjusting baseline Oroville releases and Banks pumping from July through September of some years. Logic in TOM adjusts Oroville releases and Banks pumping to create a more regular monthly pattern of available export capacity.” The EIS/R stated that only Reclamation facilities and water transfers would be covered under this document and that any SWP operations in conjunction with this project would be subject to prior DWR approval and a separate environmental document. This analytical assumption seems to belie that EIS/R statement as the modeling assumptions clearly are counting on SWP operations to facilitate the water transfers covered under this environmental document. The EIS/R modeling assumptions must remove the assumption that SWP operations will be altered to facilitate these CVP water transfer operations.
- Pg B-17, B.4.3.1.8.1, – “East Bay MUD diverts both CVP Project water and transfer water at the Freeport Regional Water Project on the Sacramento River near Freeport.” The water transferred by East Bay MUD through the CVP facilities is covered by the OCAP BOs water transfer provisions. The Freeport Regional Water Project facility is not part of the SWP or CVP that is covered under the OCAP BOs and therefore the ESA species impacts of transferring water through these facilities is not covered by an incidental take permit and must seek ESA consultation prior to implementation.
- Pg B-18, B.4.3.1.8.2, p1 – “Contra Costa WD diverts water under existing water rights, a CVP water service contract, and transfer water from multiple points of diversion in the Delta.” The CCWD facilities are not part of the SWP or CVP that is covered under the OCAP BOs and therefore the ESA species impacts of transferring water through these facilities is not covered by an incidental take permit and must seek ESA consultation prior to implementation.
- Pg B-18, B.4.3.1.8.2 (this was a document numbering error, it should have been B.4.3.1.8.3), p1 – “Transfer water purchased by SLDMWA is conveyed through available export capacity at Jones and Banks pumping plants. Transfers from the Sacramento River assume a 20 percent carriage water adjustment to maintain Delta salinity. Transfers from Merced ID that enter the Delta from the San Joaquin River assume a ten percent carriage water adjustment.” The EIS/R must disclose the basis and justification for these carriage water assumptions.

113

114

115

116

117

118

119

- Under some conditions, the carriage water requirements to maintain delta water quality would have to be much higher, e.g. 30 or 40%. 119
- Pg B-18, B.4.3.1.8.2 (this was a document numbering error, it should have been B.4.3.1.8.3), p2 – “Additionally, water made available by Merced ID can be conveyed directly to SLDMWA member agencies through facilities that connect to Merced ID’s internal conveyance system and facilities that join the lower San Joaquin River and the DMC without going through CVP/SWP export facilities.” These facilities and operations are not covered under the OCAP BO operations or water transfer assumptions so these operations must seek separate ESA consultation with the fisheries agencies prior to implementation. 120
 - Pg B-18, B.4.4 – The EIS/R must disclose its assumptions as to what projects they included as reasonably foreseeable. If they are elsewhere in the document, the mention of these assumptions should have included a reference as to what section that content could be found. In general this EIS/R is very poor at making the document reader friendly. 121
 - Pg B-20, B.6.1, – “...they would need to complete individual NEPA and Endangered Species Act compliance for each transfer...” Buyers and sellers will need to complete ESA consultations anyway as the OCAP BOs only cover SWP and CVP water transfer activity and specifically exclude coverage of buyer and seller area impacts. 122
 - Pg B-20, B.6.2, – “Alternative 2 includes transfers under all potential transfer measures: groundwater substitution, reservoir release, conserved water, and crop idling.” Again, the assumptions leave out crop switching which has very different modeling implications to water use, savings and conveyance than crop idling. The current EIS/R modeling assumptions do not reflect all of the actions included in alternative 2 and the analysis must either be redone with the corrected assumptions or the description of and actions included in alternative 2 must drop crop switching as a component. 123
 - Pg B-23, Figure B-14 and Pg B-28, B-24 - The EIS/R stated that only Reclamation facilities and water transfers would be covered under this document and that any SWP operations in conjunction with this project would be subject to prior DWR approval and a separate environmental document. This analytical assumption seems to belie that EIS/R statement as the modeling assumptions clearly are counting on SWP operations to facilitate the water transfers covered under this environmental document. The EIS/R modeling assumptions must remove the assumption that SWP operations will be altered to facilitate these CVP water transfer operations. 124
 - Pg B-29, Figure B-27 – This figure demonstrates the point regarding project impacts on proportional flows at tributary confluences on salmonid homing and straying. The information to conduct the analysis of project impacts on straying is clearly available and yet the EIS/R did not conduct that analysis, disclose the impacts or mitigate the impacts. 125
 - Pg B-66, Appendix B, attachment 1 – The 2005 level of development should not have been used in that the rest of the modeling updates were current up to January 2014. This out of date level of development assumption biased the analysis results as the 2014 level of demand is higher than it was in 2005. 126
 - Pg B-66, Appendix B, attachment 1 – The Baseline Assumptions did not include implementation of the existing OCAP BO RPA requirements for restoration of subtidal and intertidal habitat and floodplain habitat. The subtidal and intertidal habitats have tidal exchange impacts to delta water quality and CVP/SWP operations that must be included in the modeling assumptions. These are reasonably foreseeable as they are current legal obligations of the CVP and SWP that are required to be implemented prior to 2015. Since the implementation deadline is so close, the location, design and operational characteristics must be thoroughly defined by now or DWR and Reclamation will not be compliant with the 127

BO requirements. The floodplain habitat restoration results in altered water quality and water consumption from evapotranspiration and changes in the tidal prism that must be accounted for in the modeling and impact analysis. The modeling assumptions must be revised and the analysis rerun to reflect these current legal obligations of the CVP and SWP under the OCAP BOs.

- Table C-17, p1 – “Although D-1641 specifies 14-day durations for mean daily chloride concentration, since most DSM2 boundary conditions are specified as monthly values, it is not sensible to account for this constraint herein.” DSM2 reports data on 15 minute time increments, so the data from DSM2 is readily available to do the analysis to determine the frequency, duration and magnitude of exceedances of this water quality parameter as defined and required by D-1641. The EIS/R must use the best available science and this readily available DSM2 data to complete this study. The failure to use the best available is unsupported.. The quantity of data available from DSM2 is why this data is always presented as exceedance graphs to show the frequency, duration and magnitude of water quality exceedances. Monthly averages of this data mean nothing and are obviously designed by the project to obscure the impacts of the project. The EIS/R must be revised to include exceedance plots of the full time series of data that is available from DSM2. This comment applies to all water quality evaluations done from DSM2 data.
- C.9 – p2 – “1. the daily minimum stage was calculated for all the Base and three Alternative from the 15-minute model output ; 2. daily change from Base stage was calculated (Daily Alternative Min Stage – Daily Base Min Stage) 3. monthly average stage was calculated from the results at step 2.” So the analysis took two daily time step data sources and decided to water it down to a nice monthly average that is designed to hide all but extraordinary catastrophic impacts. Dewatering an ag intake does not have impacts on a monthly basis, it is an impact that occurs on a day by day basis. With the current analysis, the intakes could be dewatered by 6” for 20 of the 30 days of a month and then covered by 1’ of water for the last 10 days and still show no impact. This analysis and any other used in the EIS/R that used daily source data and analyzed it at a monthly average for the impact assessment must be revised to reflect a best available science use of the full potential of the data sets for a daily impact analysis.
- C-48, p4 – The Proposed Project “...alternative sees the largest increases in EC when exports are the greatest, with Critical water years in July seeing the largest percent difference of 4.2% at the SWP location and 3.3 % at the CVP location.” This is a very significant impact as the SWP and CVP are constantly in violation of these water quality parameters in Critical water years already. For the proposed project to make that violation worse by over 4% is a very significant impact that must be mitigated.
- D.3.6, p1 – “The distribution of aquifer properties across the Sacramento Valley is poorly understood. In certain areas with significant levels of groundwater production, the collection of aquifer test data and the measurement of historical groundwater-level trends in response to known groundwater production rates have provided valuable information on aquifer properties. However, in the majority of the valley, these data are not available.” Yes, this may be true, but it also invalidates the use of modeling for predicting groundwater and surface water interactions. This model is not generally accepted for these types of analyses and its use for this kind of document and analysis in this geographic area is unprecedented. Peer review and supporting acceptable calibration is not apparent.
- Appendix D – The documentation fails to disclose the assumptions used in the model of how the groundwater substitution was geographically distributed or that the model used actual well locations that would be used under the Proposed Project and alternatives. Based on the

127

128

129

130

131

132

very generalized description of the data, we conclude that the model used an assumption of an average groundwater source usage distributed evenly across the seller areas. This assumption of course would have no relationship to reality or the impacts that would occur with implementing the project within the boundaries of how it was described. The generalized assumption of distributed groundwater well locations and demand would vastly underestimate the localized groundwater and surface water interaction impacts from the project that would be implemented such that those impacts were not uniformly distributed. The groundwater analysis in the EIS/R must be redone using an accepted model, with specific well locations and water demands.

132

- Figure D-4 – There are almost no well data points to characterize the hydraulic conductivity of the aquifer in the Feather River basin in which many seller areas were identified. These areas have almost no data to support the model analysis which render the results unreliable.

133

Baseline Definitions

- The EIS/R No Action/Project assumptions were not consistent with the BDCP EIR/S and Reclamation Remand EIS. Since Reclamation is a lead agency for all of these projects and they are all on the CVP operations and they all occur over the same time period, it is an inexcusable inconsistency and bias in the outcomes of the analysis to have different baseline assumptions. Since the other documents have undergone public review already, this project's No Action/No Project assumptions must be revised to be consistent with these other documents, reanalyzed and revised, and then recirculated for public comment.

134

Impact Analysis Geographic Scope

- The geographic area included in the EIS/R impact assessment fails to include areas and tributaries downstream of drainage from water transfer recipient service areas. Transferred water will be applied to buyer areas and some of that water will result in runoff that will be carried downstream of those service areas. Those water transfer runoffs will alter flows and water quality in those downstream tributaries. Some of those downstream tributaries that should have been included in the EIS/R analysis, but were not, include (but are not limited to): San Joaquin River, Coyote Creek, Liaghs Creek, Pescadero Creek, Uva Creek, Stevens Creek, Beryessa Creek, Alameda Creek, Tassajara Creek, Walnut Creek, Marsh Creek, Kellogg Creek, Lone Tree Creek, Hospital Creek, Corral Hallow Creek, Ingram Creek, Salido Creek, Crow Creek, Orestimba Creek, Garzas Creek, Quinto Creek, Romero Creek, Los Banos Creek and others. The San Joaquin River and several of these creeks are documented habitat for ESA species salmonids and therefore the lack of analysis of these ESA species impacts in the EIS/R is a particularly egregious omission.
- The geographic area included in the EIS/R impact assessment fails to include areas from the reservoirs involved in the project to the upstream first impassable fish barrier. Fluctuations of the reservoirs from project releases affect the ability for reservoir fish to forage and

135

136

spawn in the upstream tributaries. The project operations reduce reservoir cold and warmwater fisheries access and use of these upstream habitats from exposing sediment wedges in the tributaries at the interface with the reservoir and increasing the frequency and duration of impassable conditions for fish. Cold and warmwater fisheries are designated beneficial uses of water in the CV Basin Plan and therefore must be evaluated in a revised EIS/R.

136

- Both seller and buyer service areas are in unconfined groundwater basins. The impact area of groundwater resources, surface water interactions with groundwater, and fisheries and wildlife resources in the adjacent groundwater basins connected to these seller and buyer service areas must also be fully analyzed in the EIS/R. As the EIS/R stands, these extended impact areas in the interconnected groundwater basins are not identified, characterized, evaluated, quantified, mitigated or disclosed. This serious omission in the extent of the geographic area of impact from the project must be corrected in the revised EIS/R.

137

Impact Analysis Significance Criteria

- The EIR must use a full range of significance criteria which are consistent with Reclamation's use in other similar environmental documents. These similar environmental documents from which Reclamation should use the significance criteria include: Remand EIS, Shasta Enlargement, Sacramento Valley Water Management Plan (AKA Phase 8), CALFED, and BDCP. For this project to use anything less than the synthesis of the significance criteria from these recent and similar projects with Reclamation as the lead agency would be an inconsistent application of policy, procedure and science. The EIS/R impact analysis must be revised to address them missing impact criteria and thresholds. The revised EIS/R must be recirculated after addition of this material new information.

138

Permits Needed by the Project

- ESA Incidental Take Permit – Impacts from the selling and receiving water service areas are not covered by the OCAP BOs. They will require separate section 7 consultation (BA and BO). NMFS OCAP BO, pg729, p3 - "...this consultation does not address ESA section 7(a)(2) compliance for individual water supply contracts. Reclamation and DWR should consult with NMFS separately on their issuance of individual water supply contracts, including analysis of the effects of reduced water quality from agricultural and municipal return flows, contaminants, pesticides, altered aquatic ecosystems leading to the proliferation of non-native introduced species (*i.e.*, warm-water species), or the facilities or activities of parties to agreements with the U.S. that recognize a previous vested water right." The water transfers ESA species impacts in the seller and buyer service areas are not covered under the FWS or NMFS OCAP BOs and therefore a separate section 7 or 10 consultation for the water transfers for the seller and buyer service areas must be conducted and approved prior to the water transfers.
- Reclamation and DWR have not implemented the OCAP BO RPAs, so the CVP and SWP are not compliant with the terms of their current Incidental Take Permits (ITP). NMFS

139

140

specifically provides in the OCAP BO that if the agencies are not compliant with the terms of the OCAP BO RPAs that they will rescind their ITP. Since DWR and Reclamation are not compliant with the OCAP BO RPAs (see related comments), NMFS must rescind Reclamation and DWRs ITP and reinitiate ESA re-consultation. FWS and NMFS cannot approve the permits for the proposed water transfers until OCAP BO compliance is achieved.

- The project will require a 401 Clean Water Act certification to address all types of discharges that occur under the proposed project and alternatives. These discharges by the project which must be permitted include (but are not limited to): releases from each reservoir to each tributary involved in the transfers, leaks from conveyance used in the water transfers (e.g. California Aqueduct), discharge at the water transfer recipient service area, discharges of water used in the buyer service areas, discharge groundwater pumped for groundwater substitution, discharge of groundwater substituted water after use on the fields. These last categories of discharges from groundwater wells and drainage discharge of groundwater substituted fields represent new locations of discharges for the project that would not be covered under any 401 permits the SWP or CVP currently have (if they have any).
- The project will also need Air Quality permits for project impacts from (but not limited to): electrical load demand from groundwater pumping (this increased electrical load is not offset by not surface water pumping), changes in the timing and location of electrical generation from backing up water in reservoirs for transfer (the foregone generation must be replaced and the timing of the impacts are different), idling crops causes wind erosion and airborne particulate loads, operating equipment on fields receiving water from transfers in the buyer service areas are emissions that would not happen under the No Action/Project. All of these impacts are different from the conditions of the CVP and SWP without the project so these impacts are not covered by any current CVP or SWP air quality permits (if they have any).

Water Supply

- The EIS/R must be revised to evaluate the year to year potential geographic distribution of the sellers and to evaluate the worst case scenario of the distribution (or lack thereof) of the sellers. Since the EIS/R did not evaluate a worst case scenario for how the sales would be distributed, the project must not be approved or permitted for operations that would result in more geographically concentrated impacts than what was represented in the analytical assumptions in the EIS/R. The EIS/R assumed an average water transfer contribution from all seller areas for the available transfer capacity for each water year type. With these assumptions, the impacts are equally spread and are reduced in severity in any geographic location the most of any of the potential operational scenarios. The EIS/R should have conducted and disclosed some sensitivity analysis in which the extremes of operational scenarios were tested and evaluated for their environmental impacts. Several of these scenarios that represented the worst potential impacts from the project should have been fully evaluated. Only under that approach could the project be awarded permits that allow the full amount of water transfer proposed under a set of mitigations that would have addressed the impacts. The analysis took the most optimistic (and completely unrealistic) assumption of even geographic distribution water transfer operations and impacts, each of the identified seller areas should be only allowed to transfer the averaged amount of water that was actually analyzed in the EIS/R. Here is a description and analysis of

140

141

142

143

the critically flawed assumptions the impact analysis used in its impact analysis. The maximum proposed water transfer by the identified water sellers is 511,094AF. In all water years except Critical, Consecutive Dry, and Dry after Critical; the FWS OCAP BO says that the maximum transfer that can be conducted under the permitted conditions is 360,000AF. The EIS/R makes the erroneous assumption that the 360,000AF would be evenly distributed across the seller's area. In reality, the impacts would never be so perfectly distributed and reduced in their severity. The EIS/R should have tested a number of scenarios in which the transfer water was concentrated with various combinations of sellers. The EIS/R should have evaluated the impacts of all of the transfers coming from a single drainage basin under these limited subscription conditions, e.g. all from the Feather River or American River basin and none from the Sacramento River/Shasta drainage basin or visa versa. The scenario of all water transfers from one basin and none from another basin is very plausible as snowpack could favor one basin over another and make more or less water available for transfer or operational considerations of reservoirs in one basin vs. the other could make water storage much more feasible. The EIS/R should have evaluated at least two scenarios of different distribution of willing sellers. These are: all available sellers from the Sacramento and Feather River Service area with none from any of the other seller service areas and another scenario of all transfers being from Merced River, Delta, American River, Yuba River, and Feather River with none from the Sacramento River.

- The EIS/R does not analyze the impacts of the proposed project and alternatives on other existing long-term (e.g. YCWA Lower Yuba River Accord) or year-to-year water transfer opportunities. The proposed project and alternatives preclude or significantly reduce the amount of potentially available excess CVP and SWP capacity for other long- and short-term water transfers which compete to use these same CVP and SWP facilities. Some of the Lower Yuba River Accord water transfers are for environmental objectives. Some or all of these transfers may not occur under the proposed project or alternatives. This is unknown because the EIS/R failed to identify, characterize, evaluate, quantify, mitigate or disclose the impacts to these other water transfers. This omission is a material deficiency of this EIS/R document which must be revised and recirculated.
- The EIS/R proposed "paper water accounting" as the basis for some of its analysis. As an example, the project description says that "These agencies... would use the water diverted from the San Joaquin River in exchange for their CVP water from the Delta-Mendota Canal." (EIS/R page 2-25, p3). The impacts of the other 4 proposed conveyance routes and operations are very different from the foregone diversions of these other water districts in favor of the proposed San Joaquin River diversion impacts. The different impacts of these different proposed modes of accomplishing this Merced ID water transfer were not analyzed, mitigated or disclosed in the EIS/R. These material omissions and deficiencies in the EIS/R must be corrected in the revised and recirculated EIS/R.
- If the transferred water is allegedly conserved and does not result from and is limited to an actual reduction in consumptive use (which will vary with the climate) it could reduce runoff to surface flow and percolation to recharge the groundwater.
- Is water transferred from outside of basin? E.g. Feather River basin surface water rights transferred, but delivered from Shasta?
- Operational assumptions for reservoir storage for water transfer failed to take into account operational changes required by the OCAP BO RPAs for fish passage at Shasta, Folsom and New Melones.

143

144

145

146

147

148

- The EIS/R analysis should be specific on the operations and impacts for each water transfer in order to justify project-level permits required for implementation of the project. The level of specificity of the current EIS/R is only at a programmatic level of detail so the project should be subject to additional project level impact analysis prior to implementation each year. 149
- The EIS/R analysis should be specific on the operations and impacts for each water transfer and cumulatively for year to year for the project and in combination with all current and other reasonably foreseeable projects, e.g. Lower Yuba River Accord water transfers. 150
- Each river, stream and location has different geology and hydrology. The EIS/R analysis did not incorporate analysis of all potential operational scenarios that could occur under the range of operations and conditions included in the project description. The project should only be permitted for the operations and conditions analyzed, mitigated and disclosed in the EIS/R, not on the range proposed that were not addressed in the analysis. 151
- Water transfers from this project result in discouragement of investment in water conservation or adaptation of water users to more sustainable water uses in the Buyer Service areas. If you can buy water cheaper than the cost of implementing water conservation to achieve an equal amount of water supply then you will always choose the cheaper option of buying the water. This is also why desalination projects or other new water or major conservation efforts (e.g. fixing all the water conveyance leaks) will never occur until all the cheaper water that exists is purchased and transferred. This project and others like it, result in a California that will continue to take water from each other until there is no more water to take before it makes any meaningful investment in water conservation, alternative water supplies, and changes in lifestyle related to water use (hundreds of golf courses in the desert) and water allocation. The BDCP does not count as a project to create new water as this project claims that it “won’t divert any more water than current operations” and the real purpose of that project is to just facilitate the transfer of water from a poorer Northern California to a richer Southern California. 152
- CVP and SWP operations are often constrained by net delta outflow requirements. The Net Delta Outflow Index (NDOI) that the SWP and CVP are currently using is grossly over-reporting net delta outflow. “While the NDOI is, at best, an estimate of Delta outflow, there are stations that accurately measure actual Delta outflow. The United States Geological Survey (USGS) has established a series of stations in the Delta to measure flow and water quality parameters.” “Four of the USGS gauging stations... accurately measure Net Delta Outflow (NDO).” (*The Case of the Missing Delta Outflow*, California Sportfishing Protection Alliance) DWR’s own analysis of NDOI (“Dayflow”) estimates vs. the new more accurate USGS gage measurements indicates that the “Dayflow under estimates flow during wet periods and over estimates flow during dry periods.” (http://www.water.ca.gov/dayflow/docs/2013_Comments.pdf) This DWR report means that during the majority of the CVP and SWP diversion season (spring through fall), the operations systematically over estimate NDOI and systematically divert more water from the south delta than regulatory operational constraints would allow if NDO was correctly accounted for. As a result of this over-estimation of net delta outflows and the resulting lack of operational constraint, Reclamation and DWR’s evaluation of available excess capacity for water transfers for this project will result in more capacity being identified as available as actually would exist if 153

the delta net outflows were being accurately measured. The EIS/R must include an evaluation of the accuracy of the Delta Net Outflow Index accuracy and an adjustment for the water transfer delivery quantities that would result from correctly adhering to the operational constraints of the CVP and SWP from Delta Net Outflow Index requirements. This regular exceedance of regulatory constraints on the CVP and SWP operations must be evaluated in this EIS/R and water transfer amounts included in the project must be limited to amounts that would not result in the CVP and SWP violation of net delta outflow requirements. This over estimation of net delta outflow also results in insufficient carriage water being pulled out of the water transfers to maintain delta water quality and CVP/SWP operational compliance with the OCAP Biological Opinions and the Reclamation Remand court order.

- Coordinated CVP/SWP operations, funding and water deliveries are based on the COA. The COA is grossly out of date and has not been updated since 1986. COA determines the proportional distribution of available water supplies and operations. If the COA were updated, the amount and locations of excess capacity in the SWP and CVP system would change. This project must include an update to the COA as part of the scope or the actual amount of conveyance capacity available for transfers cannot be determined.

Water Rights

- Water rights were not addressed at all in the ES impact summary table.
- In 2014, some federal water contractor's had stored some water from the previous year for later release at Reclamation's Friant facility. Due to the drought conditions and lack of available water supply in 2014, Reclamation decided to deliver that water contractor stored water to the Exchange Contractors to fulfill their other standing obligations to the Exchange Contractors rather than to the water agencies that stored their water in Friant. The EIS/R does not address this potential scenario in released water from reservoirs or the "backed up" water operations of the Proposed Project or alternatives. As a very similar scenario example for the Proposed Project or alternatives, water stored in Friant for Merced Irrigation District that was held back specifically for a water transfer could be hijacked by Reclamation to service the Exchange Contractors instead. This scenario could easily occur on the other dams with backed up water released to fulfill minimum flow or senior water rights holders on the downstream tributaries rather than for the project water transfers. Again, there is a difference in the timing and location of impacts for when the water is released and where it is used for the project or for other obligations. Without the project, the backed up water would not have existed so there would not be the impacts of releasing that water to fulfill these other obligations. The difference in release timing and location of use create impacts that the EIS/R did not identify, characterize, evaluate, quantify, mitigate or disclose.
- When downstream senior water right holder settlement agreement (settlement contractors, e.g. Shasta - Tehama and GCID; Oroville – WCWD, BWGWD, Richvale, etc.) water supply is released from storage for transfer to the water buyers under the Proposed Project and alternatives, it may include natural flow water or stored water which is in violation of permit

terms and conditions from their Settlement Agreements. The water rights that the settlement contractors have under the settlement agreement are not the same as their original pre-1914 or riparian water right so they should not have the senior water right status for the water transfer. Since they do not have this senior water right status, these actions must not be allowed to affect parties with more senior water rights. All water transfers must be subject to water rights priorities. The EIS/R is deficient as it did not correctly differentiate the water rights level of the settlement contractors and allowed these water transfers to impact the water rights (water quality) of more senior water rights holders.

- The analysis should cover the requirement or recognition that no water can be exported from the Delta by the projects unless the Delta is first provided an adequate supply (WC 12200 etseq.) and to the extent the transfer is dependent on the water rights of the SWP or CVP the water can be recaptured to serve needs in the watersheds of origin (WC 11460 etseq.).
- Reclamation and DWR water rights are subordinate to senior rights and conditioned on compliance with statutory requirements as well as permit conditions. The CVP and SWPs post-1914 water rights are junior to most in-Delta water rights and, as a result, the project has no right to divert the natural flows within the Delta if there is not enough natural flows through the Delta to satisfy in-Delta pre-1914 appropriative rights. The CVP and SWP, as junior water rights holders, are also not allowed to impair the water quality of the senior water rights holders from the operational impacts of their diversions. Reclamation and DWR, through their CVP and SWP operations, consistently violate these water quality standards and impact the beneficial uses of water for agricultural use of the senior water rights holders in the delta.
- The SWRCB cannot certify or issue permits on a project which knowingly and consistently violates state surface water rights and the addition of these water transfers under the Proposed Project and alternatives would only exacerbate the frequency, magnitude and duration of these violations. Area of Origin Statutes were enacted during the years when California's two largest water projects, the Central Valley Project and State Water Project, were being developed to protect local Northern California supplies from being depleted as a result of the projects. County of origin statutes provide for the reservation of water supplies for counties in which the water originates when, in the judgment of the State Water Resources Control Board, an application for the assignment or release from priority of State water right filings will deprive the county of water necessary for its present and future development. Watershed protection statutes are provisions which require that the construction and operation of elements of the Federal Central Valley Project and the State Water Project not deprive the watershed, or area where water originates, or immediately adjacent areas which can be conveniently supplied with water, of the prior right to water reasonably required to supply the present or future beneficial needs of the watershed area or any of its inhabitants or property owners. The addition of these water transfers under the Proposed Project and alternatives would only exacerbate the area of origin conflicts.

157

158

159

160

- The Delta Protection Act, enacted in 1959 (not to be confused with the Delta Protection Act of 1992, which relates to land use), declares that the maintenance of an adequate water supply in the Delta--to maintain and expand agriculture, industry, urban, and recreational development in the Delta area and provide a common source of fresh water for export to areas of water deficiency--is necessary for the peace, health, safety, and welfare of the people of the State, subject to the County of Origin and Watershed Protection laws. The act requires the State Water Project and the federal CVP to provide an adequate water supply for water users in the Delta through salinity control or through substitute supplies in lieu of salinity control. The addition of these water transfers under the Proposed Project and alternatives would only exacerbate the water supply conflicts addressed under the Act. 161
- In 1984, additional area of origin protections were enacted covering the Sacramento, Mokelumne, Calaveras, and San Joaquin rivers; the combined Truckee, Carson, and Walker rivers; and Mono Lake. The protections prohibit the export of ground water from the combined Sacramento River and Sacramento-San Joaquin Delta basins, unless the export is in compliance with local ground water plans. Also, Water Code Section 1245 holds municipalities liable for economic damages resulting from their diversion of water from a watershed." (<http://www.waterplan.water.ca.gov/previous/b160-93/b160-93v1/ifrmwk.cfm>) The addition of these water transfers under the Proposed Project and alternatives would only exacerbate the water supply and groundwater conflicts addressed under the water code. 162
- Reclamation is not compliant with their junior water rights requirements as the CVP operations frequently exceed Delta water quality requirements in violation of the Delta Protection Act of 1959. Transfers of water supplies through the CVP or SWP from conjunctive use of groundwater substitution for surface water supplies are not consistent with local groundwater plans. Water contractors supplied through the SWP are liable for any direct or indirect damages from diverting water from a watershed. These damages may include injury, damage, destruction or decrease in value of any such property, business, trade, profession or occupation resulting from or caused by the taking of any such lands or waters, or by the taking, diverting or transporting of water from such watershed. (Water Code 1245) The addition of these water transfers under the Proposed Project and alternatives would only exacerbate the water quality impacts addressed under the Act. 163
- The Proposed Project and alternatives must consider the water supply, water rights, water quality impairments and other water beneficial use impacts associated with the water transfers of south delta water. The conditions of waters in the delta including direction of flows, water quality and impacts to agriculture, drinking water supplies and fisheries resources are a direct consequence of the CVP and SWP south delta facilities water diversions. 164

Water Quality

- The sellers identified are mostly water districts. When water districts transfer water they typically rotate the fallowed lands from year to year so not the same land or owners are participating from year to year. The EIS/R just assumes there will be some even distribution of the fallowed fields across a water district. They do put some constraints on adjacency to wildlife refuges, but other than that, the fallowing could occur in any location or in any combination of locations or concentrations. By not having specific locations or a very specific rule set about how fallowed fields can be distributed within a water district, the 165

analysis of the impacts from field fallowing is at a programmatic level of detail, not a project site specific level of detail. The rules for how fallowed fields are distributed in a water district are not specific enough to allow detailed analysis of impacts such as reduced ag drainage return flows and resulting drainage flows and water quality impacts. The EIS/R must be revised such that project specific levels of detail on the impacts of field fallowing are conducted. Although the agencies can approve a programmatic EIS/R, this project, because of its lack of project-level analysis of impacts, must have a subsequent environmental analysis prior to implementation.

- Each groundwater basin and sub-basin area has different water quality, e.g. south of Sutter Buttes has higher saline groundwater than farther to the north. Different depth groundwater aquifers can have different water quality. The differences in groundwater quality that would be substituted for surface water supplies and the specific differences in the water quality of discharge water from the conjunctive use properties in the project are not characterized, evaluated, quantified, mitigated or disclosed in the EIS/R. This material omission of groundwater substitution water quality impacts on surface and groundwater quality must be addressed in a revised and recirculated EIS/R.
- Ag drainage water quality is lower in the areas of groundwater substitution than if their surface water supplies were utilized. As an example of the impact of the project, groundwater is higher in dissolved minerals (TDS) than surface water. High dissolved minerals in water can have significant adverse impacts on development of juvenile salmonids that occur in the tributary reaches where the proposed project surface water quality degradations would occur from groundwater substitutions. The Sacramento Valley Regional Water Plan (AKA Phase 8) identified and addressed those impacts in their project's conjunctive use analysis, but this project EIS/R did not even though Reclamation was a lead agency on both projects and both involve conjunctive use.
- The EIS/R also failed to evaluate the impact of fallowed fields on reduced ag return flow volumes and increased contaminant loads which could exceed the discharge permits tolerances, e.g. water temperature difference, TDS, DO, nutrient loading, DOC, ECw, contaminant metals (Hg, Se, Pb, Fe) other (diaznon, DDT, chlorpyrifos, etc.) of the water and reclamation districts. This is a material omission and deficiency of the EIS/R which must be corrected in the revised EIS/R prior to recirculation.
- The Proposed Project and alternatives will result in water quality impacts to delta and other beneficial uses which were not fully addressed in the EIS/R.
- The Proposed Project and alternatives idling of fields will result wind erosion of soils which will be deposited into tributaries which will degrade water quality of those tributaries with the associated contaminant loads. The contaminant loads from fallowed field wind and water erosion into surface water tributaries was not fully addressed in the EIS/R because the location and number of fields was not defined by the Proposed Project and alternatives. This significant impact must be more specifically analyzed for the field locations, number and distribution and the significant impacts to surface water quality mitigated and disclosed.

165

166

167

168

169

170

- Water quality impacts vary greatly depending on the tributary and groundwater substituted, e.g. Berryessa and Putah Creek flow transfers would mobilize a disproportionate amount of Hg. Transfers from Friant to Westlands would mobilize a disproportionate amount of Se. Both of these project impacts are not fully addressed in the EIS/R. This significant impact must be more specifically analyzed for the tributary locations, timing of substitution and transfer, and volume of those transfers and the significant impacts to surface water quality for the project mitigated and disclosed.

171

Groundwater

- If the transferred water is based on an actual reduction in consumptive use (which will vary with the climate) it will reduce runoff to surface flow and percolation to recharge the groundwater. As an example, ag irrigation quantities include a component for leaching salts below the plant root system. The leaching component of irrigation water contributes to groundwater recharge. In the case of proposed project idling of fields or crop switching to lower water use crops, that irrigation leaching component contribution to groundwater recharge is significantly reduced or eliminated all together. The EIS/R failed to identify, characterize, evaluate, quantify, mitigate or disclose this significant impact from the Proposed Project and alternatives. This material omission in the analysis of the EIS/R must be rectified and submitted for public review in a recirculated document.
- Groundwater drawdown affects of the proposed project and alternatives on adjacent groundwater wells and changes in direction or magnitude of groundwater hydraulic gradient on contribution to surface water flows was not addressed in the EIS/R. The EIS/R Regional Economics section identified "Groundwater substitution transfers could increase groundwater pumping costs for water users in areas where groundwater levels decline as a result of the transfer." as an adverse project impact. Obviously the groundwater section missed this impact, which is a significant impact and must be mitigated.
- Subsidence impacts from groundwater drawdown in the seller service area as a result of the project were not addressed in the EIS/R. The EIS/R only addressed the reduction of groundwater subsidence in the buyer's service area as a benefit. Since groundwater substitution in the sellers area is a significant component to the source of water for transfer, the one sided and biased EIS/R analysis where the beneficial impact is disclosed, but the significant adverse impact is ignored and goes unmitigated and disclosed, There is an egregious violation of the requirements and intent of NEPA and CEQA.
- The amount of groundwater substitution/transfer cannot be greater than the maximum sustainable yield or groundwater aquifer collapse occurs. The Proposed Project does not provide operational limits and the EIS/R analysis does not determine how much water can be sustainably withdrawn from groundwater aquifers without risk of collapsing them. The Proposed Project does not define how much groundwater substitution would occur in each seller area from year to year. With both of these critical information components missing in order to ensure protection of the groundwater aquifers, the EIS/R document is deficient and must be revised to correct these omissions. In order to avoid and mitigate the significant impact of the project on groundwater subsidence, the project must include an alternative

172

173

174

175

for a sustainable rate of groundwater withdrawal and/or propose the sustainable rate of groundwater withdrawal as a mitigation of the impacts of the current Proposed Project and alternatives. This “sustainable groundwater alternative” extraction and transfer amount can be calculated for each seller service area groundwater basin using the following generalized methodology. First, determine the current size (TAF) and annual groundwater recharge for each groundwater basin for the 82 year period of hydrologic record. Second, determine the safe and sustainable annual quantity of groundwater yield (including maximum rate of groundwater withdrawal without collapsing water bearing strata) in each basin. Now add the groundwater basin (with size, recharge rates and maximum sustainable rates of withdrawals) as a “reservoir” for each groundwater basin and seller service area to CALSIM (or in a post processing module for analyzing CALSIM results). Next, using the 82 year period of record and the CALSIM model, optimize the amount of seller area water deliveries for each groundwater basin area. Determine the amount of groundwater extraction for transfer that does not accrue into an over-draft of the groundwater basin at any time during the 82 year period of record. The maximum groundwater substitution amount that does not result in over-drafting the groundwater in any year in the 82 year hydrologic period of record will be the maximum contract delivery amount for that groundwater basin and seller service area for use in the “sustainable groundwater” EIS/R alternative or as a mitigation for the significant groundwater aquifer collapse impacts of the Proposed Project. The EIS/R also fails to identify impacts to infrastructure (roads and bridge structural integrity and safety, canal capacity and structural integrity and safety), and other resources (such as surface water drainage) that occur from groundwater withdrawal caused ground level subsidence.

175

Geology and Soils

- The EIS/R evaluated the potential loss of top soil from fallowing, but did not address the different soil erosion potentials that occur in different seller areas. The EIS/R analysis must be revised to reflect the site specific soil erosion characteristics at the seller areas; otherwise the analysis is programmatic rather than project specific and would require subsequent environmental analysis prior to implementation of the project.
- The EIS/R did not address salt accumulation and resulting reductions on soil productivity from the water transfers on the buyer areas. The EIS/R analysis must be revised to reflect the continued and increased salt accumulation of soils and reduced soil productivity from the proposed water transfers.
- Water released from CVP or SWP facilities for water transfers is on top of the water that would have been released in the No Action/No Project. Most of the water transfer releases of the Proposed Project will be on top of higher natural flows so that less carriage water is required and water diversion yields of the transferred water will be highest at the south delta pumps. This extra flow increment of the transferred water on top of the flows that would be there under the No Action/No Project will result in increased erosion of banks in the tributary reaches below the dams. As an example of this impact, see DWRs settlement agreement and

176

177

178

compensation to Emerald Farms on the lower Feather River from increased erosion from the SWP operations. These flow related impacts to bank erosion are a real impact of the Proposed Project and alternatives. The EIS/R failed to analyze these identify, characterize, evaluate, quantify, mitigate or disclose these impacts.

178

Air Quality

- The EIS/R identifies a benefit from the reduction of emissions from farm equipment that would not be operated on fallowed water seller fields, but does not address the increase in emissions from farm equipment being operated on buyers fields that would have otherwise been fallowed. This shifting of air quality impacts from farm equipment operations from northern California to the southern central valley is a significant impact as the northern counties generally do not have a problem meeting their air quality attainment requirements and the bay area and southern central valley counties are constantly in violation of their air quality attainment requirements. The EIS/R identification of a beneficial impact while ignoring the more than offsetting corollary significant impact demonstrates the one sided biased nature of the impact assessment. The EIS/R must be revised to disclose and mitigate the air quality impacts of the farm equipment operated in the buyers area under the proposed project which would not occur under the No Action/No Project.
- The EIS/R claims that dust from fallowing fields is an overall benefit because there is no tilling and harvest associated dust. This analysis and conclusion is completely biased and is not supportable. Much more soil is eroded from a field that is fallowed and bare of all vegetation all year as compared to a field that is tilled and harvested. This impact is not a benefit, it is a significant impact that must be mitigated.
- Increased air pollution from increased groundwater and other pumping (e.g. CVP/SWP lift pumps and groundwater pumps) under the proposed project is a significant impact, not a less than significant impact as the EIS/R determined. This significant impact must be mitigated.

179

180

181

Climate Change

- The EIS/R analysis is fundamentally flawed because the future project condition to 2024 did not include sea level rise, precipitation or other climate change impact assumptions. NEPA requires the end condition of the project period to be analyzed, in this case 2024. The BDCP has incorporated climate change in its analysis of conditions in 2025, so this EIS/Rs omission of climate change for 2024 is a serious inconsistency in how climate change is addressed between these two similar projects. Reclamation is a lead agency on both projects, both projects cover the same water systems and geographic areas and resources; and yet the BDCP addresses climate change in 2025 and this EIS/R does not for 2024. NEPA guidance and specifically USACE and EPA in their analytical requirements for a 401 permit, require consideration of climate change. Department of Interior, USACE and EPA all have specific methods and assumptions which are required to be utilized in an EIS. The project failed to incorporate these methods and assumptions. This EIS/R must be revised to incorporate climate change assumptions in its Proposed Project, Alternatives and No

182

Action/No Project assumptions. A 401 permit for this project must not be issued without analysis that includes climate change that is consistent with Department of Interior, USACE and EPA analytical method requirements and assumptions.

- Fallowed fields do not transpire so the cooling effect of the growing crops would not occur in acres fallowed from the implementation of the proposed project or alternatives which include crop idling. Some publications have speculated that the central valley is 10+°F cooler in the summer due to crop irrigation as compared to non-irrigation of the current irrigated acres. The fallowing of crop acres from the project would have similar impacts as those widely recognized for urban heat island effects. The EIS/R is deficient as it did not identify, characterize, evaluate, quantify, mitigate or disclose these impacts and it must be revised to address these omissions.
- Greenhouse gas emissions from increased groundwater and other pumping (e.g. CVP/SWP lift pumps and groundwater pumps) is a significant impact, not a less than significant impact as the EIS/R determined. This significant impact must be mitigated.

Aquatic Resources

- Increased deliveries of CVP/SWP south of delta service areas of Sacramento Valley basin water supply increases the proportion of “foreign basin” introduction of water and drainage water to the tributaries downstream of the water transfer receiving service areas. The water transfers under the proposed project increases the proportion of foreign basin water into the tributaries downstream of the service areas receiving these transfer waters. The out of basin water has a different signature as a homing cue for anadromous fish, especially salmonids. False attraction of migrating fish from out of basin water is well documented in published literature and is a major problem with central valley salmonid reproductive survival rates and genetic introgression which is a direct threat to the species diversity and viability. The proposed project is particularly problematic for increasing salmonid straying from out of basin water transfers in that the years where the proposed project water transfers are anticipated to be most active are the years where otherwise the CVP/SWP would have the lowest operational impacts on out of basin caused salmonid straying and genetic introgression. As an example, in 2014, CVP and SWP deliveries to the agricultural users that are the proposed project recipients of the water transfers, their 2014 water deliveries from the CVP and SWP were 0%. This means that in 2014 there would have been no straying and genetic introgression from out of basin transfers from these areas for the San Joaquin River and the South San Francisco Bay and their tributaries. With the proposed project, the out of basin transfers would occur on years of low and no CVP and SWP deliveries which will result in an increase in the proportion of out of basin water in the downstream drainage tributaries and in the rate of salmonid straying, associated mortalities and loss of fecundity and genetic introgression impacts on the species genetic integrity and diversity as compared to the No Action/No Project condition. In the case of years with 0% CVP/SWP water deliveries, to go from zero straying impact from the CVP/SWP operations under the No Action/No Project condition to some increased amount of straying impact is

182

183

184

185

an increase of infinity percent as compared to the baseline condition that occurs without the project water transfers. The EIS/R failed to identify, evaluate, quantify, mitigate or disclose this impact.

- The EIS/R must be revised to evaluate the year to year potential geographic distribution of the sellers and to evaluate the worst case scenario of the distribution (or lack thereof) of the sellers. Since the EIS/R did not evaluate a worst case scenario for how the sales would be distributed, the project must not be approved or permitted for operations that would result in more geographically concentrated impacts than what was represented in the analytical assumptions in the EIS/R. The EIS/R assumed an average water transfer contribution from all seller areas for the available transfer capacity for each water year type. The EIS/R average geographic distribution of water seller assumption for the impact analysis is actually the best case scenario for the least impacts as the impacts are equally spread and are reduced in severity in any geographic location the most of any of the potential operational scenario. Any other scenario of seller distribution would result more significant impacts than the average seller distribution assumption used in the EIS/R analysis. The EIS/R should have conducted and disclosed some sensitivity analysis in which the extremes of operational scenarios were tested and evaluated for their environmental impacts. Several of these scenarios that represented the worst potential impacts from the project should have then been fully evaluated to disclose the range of impacts that could or would be precipitated by implementing the proposed project. Only under that “bookend” of worst case scenarios analytical approach should the project be awarded permits that allow the full amount of water transfer proposed with a full set of mitigations to cover the worst case scenarios that would address these impacts. The current EIS/R analysis took the most optimistic (and completely unrealistic) assumption of an evenly distributed geographic spread of water transfer operations and impacts. Under the current set of analysis assumption that assumes only average seller water allocation in the transfers, each of the identified seller areas should be only allowed to transfer the averaged amount of water that was actually analyzed in the EIS/R. Any more water than that allowed under the operations would precipitate impacts that were not analyzed, mitigated or disclosed. Here is a description and analysis of the current critically flawed analytical assumptions the EIS/R used in its impact analysis. The maximum proposed water transfer by the identified water sellers is 511,094AF. In all water years except Critical, Consecutive Dry, and Dry after Critical; the FWS OCAP BO says that the maximum transfer that can be conducted under the permitted conditions is 360,000AF (see related comments). The EIS/R makes the erroneous assumption that the 360,000AF would be evenly distributed across the seller’s area. In reality, the impacts would never be so perfectly distributed and reduced in their severity. The EIS/R should have, as described earlier in this comment, tested a number of scenarios in which the transfer water was concentrated with various combinations of sellers. The EIS/R should have evaluated the impacts of all of the transfers coming from a single drainage basin under these limited subscription conditions, e.g. all from the Feather River or American River basin and none from the Sacramento River/Shasta drainage basin and visa versa. The scenario of all water transfers from one basin and none from another basin is very plausible as snowpack could favor one basin over another and make more or less water available for transfer or operational considerations of reservoirs in one basin vs. the other could make water storage much more or much less feasible. The EIS/R should have evaluated at least two scenarios of different distribution of willing sellers. These are: all available sellers from the Sacramento and Feather River Service area with none from any of the other seller service areas and

another scenario of all transfers being from Merced River, Delta, American River, Yuba River, and Feather River with none from the Sacramento River. To analyze the salmonid straying effects of the project (see related comments), these scenarios should have also included maximum differences in flow contributions from different operational scenarios for each tributary confluence. At the minimum, these should have included max operations on the Sacramento and no operations on the Feather River and Yuba (and visa versa), max operations on the Feather River and none on the Yuba (and visa versa), max operations on the Sacramento, Feather and Yuba rivers and none on the American (and visa versa). The concept proposed by the project of “backed up water” (see related comments) where water is released earlier in one tributary (e.g. Feather River), water is stored in another tributary basin (e.g. Shasta) and then released later in the other tributary (e.g. Sacramento River) has many more complex flow and water temperature impacts than just the raw number of acre feet in the transfer would indicate by just considering the “upper limits” of transfers as presented in the EIS/R Table 2-5. In the case of “backed up water”, the flow impacts on proportional flows at a tributary confluence are doubled. Under the backed up water operational scenario of the proposed project operations, all of the water identified by willing sellers in the Feather and Yuba River and could be released earlier than they otherwise would have in lieu of releases that would have occurred from Shasta. This results in an increase of Feather River flows and a relative decrease in Sacramento River flows at the confluence of the rivers. This is a 2x change in proportional flows at the tributary confluence (e.g. Feather and Sacramento River confluence) (+90,000AF in the Feather River and -90,000AF in the Sacramento River) as compared to the No Action/No Project during the release period. The proposed project does not define when or how short a time period a backed up water transfer could occur (presumably limited by available excess capacity for transfer), but in the absence of supported assumptions provided by the EIS/R we must assume the worst case period of time and volumes so as to be protective of the endangered fisheries species resources. If the analysis does not specify when, where and how these reservoir backup water transfers would occur, the agencies must assume the worst case scenario and limit the project permitted operations accordingly to assure ESA fish protections. Without these potential flow and temperature change analyses at the confluences of the salmonid migratory tributary confluences, the potential impacts of the range of operations that the project has proposed have not been evaluated, quantified, mitigated or disclosed. The EIS/R is deficient for the lack of this analysis which must be rectified when the document is revised and recirculated.

- The Terrestrial species impact analysis determined that “Groundwater substitution could reduce stream flows supporting natural communities in small streams” was a significant impact for alternatives 2 and 3. If groundwater impacts on streams can be significant for terrestrial species, how can it not be significant for aquatic species? The EIS/R must be revised to correct this impact call omission in the aquatic species section.
- Vegetation removal from Bouldin Island was required for a water transfer to Semitropic Water District in 2014. The herbicide application resulted in the damage to 10s of thousands of acres of agricultural crops and wildlife habitat. Since Bouldin Island is in the very middle of the delta, the herbicide spray drift that impacted terrestrial habitat would have also have to have contaminated hundreds of acres of aquatic habitat. In this case the aquatic habitat damaged included designated critical habitat for San Joaquin steelhead and Chinook salmon, green sturgeon, delta smelt and other special status species. Previous

186

187

188

water transfers have proven that this is a real risk of this type of project and these risks must be evaluated. The EIS/R failed to identify, characterize, evaluate, quantify, mitigate or disclose these very real potential impacts of the proposed project. The EIS/R must be revised and recirculated to address these material omissions and deficiencies in the document.

188

Wildlife

- The sellers identified are mostly water districts. When water districts transfer water they typically rotate the fallowed lands from year to year so not the same fields or owners are participating from year to year. The EIS/R just assumes there will be some even distribution of the fallowed fields across a water district. They do put some constraints on adjacency to wildlife refuges, but other than that, the fallowing could occur in any location or in any combination of locations or concentrations. By not having specific locations or a very specific rule set about how fallowed fields can be distributed within a water district, the analysis of the impacts from field fallowing is at a programmatic level of detail, not a project site specific level of detail. The rules for how fallowed field are distributed in a water district are not specific enough to allow detailed analysis of impacts. The lack of specificity of the location and distribution of fields also does not allow for impact analysis to wildlife. There are some vague assurances from the project about not disrupting habitat corridors, but they do not say how this would be determined, what threshold of disruption is acceptable or unacceptable. A single fallowed field is disruptive to habitat connectivity by itself, is that too much? How about two adjacent fields fallowed, too much or OK? How about 3 contiguous fields or 30 contiguous fields? The EIS/R assurances to not disrupt habitat are so vague that these questions cannot be answered and therefore these assurances by the project are meaningless. The EIS/R must be revised such that project specific levels of detail on the impacts of field fallowing are conducted. Although the agencies can approve a programmatic EIS/R, this project, because of its lack of project-level analysis of impacts, must have a subsequent environmental analysis prior to implementation.
- Farmed fields contribute wildlife habitat values for foraging, refuge, and mating. Fallowed bare ground impacts wildlife by altering habitat values and uses and overall provides lower habitat value than a cultivated field, e.g. no flooded rice when fallowed. Loss of habitat on the international flyway, which the seller areas are in a core area of, impact the United States compliance with the International Migratory Bird Treaty which was not addressed in the EIS/R.
- Southern Central Valley land that has been fallowed and is put back into production due to a water transfer will destroy the habitat values that have been created while the field was fallowed. Some of the species that move into fallowed fields that would have their habitat destroyed by putting the field back into production by the water made available by the water transfers include giant garter snake, tiger salamander, Alameda whip snake, San Joaquin kit fox, San Joaquin kangaroo rat, and others. The project failed to quantify and mitigate these impacts.

189

190

191

- If a field is fallowed for up to 10 years under the Proposed Project, habitat values will be created. The project fails mitigate for the destruction of these created habitat values that will occur at the end of the project period when these lands are put back into production. 192
- Vegetation removal from Bouldin Island was required for a water transfer to Semitropic Water District in 2014. The application of herbicide for vegetation removal resulted in the damage to 10s of thousands of acres of agricultural crops and wildlife habitat. In this case the habitat damage included critical habitat for giant garter snake, riparian brush rabbit and rat, tiger salamander, greater sandhill crane, San Joaquin steelhead and Chinook salmon, green sturgeon, delta smelt and other special status species. This spray drift damage has been well documented and publicized (<http://wineindustryinsight.com/?p=54211>, <http://www.winebusiness.com/blog/?go=getBlogEntry&dataId=135322>, http://www.lodinews.com/news/article_3c58d352-f196-11e3-8efa-0019bb2963f4.html, http://rivernewsheald.org/articles2014/bouldin_8-6-2014.html). Bouldin Island is only 5,900 acres. The proposed project could idle as much as 177,000 acres in a year if it utilized its maximum transfer capacity covered under the EIS/R using mostly the crop idling strategy component of its proposed project water conservation. If the transfers were maximized for the 10 year project period and utilized mostly crop idling as its water conservation strategy then over the 10 year project period, there would be as many as 1,770,000 acres that required herbicide treatment. If only 1% of the herbicide treatments for the proposed project water transfers go as badly as the Bouldin Island water transfer, the impact of these water transfers could damage 100s of thousands of acres of wildlife habitat. Previous water transfers have proven that this is a real risk of this type of project and these risks must be evaluated. The EIS/R failed to identify, characterize, evaluate, quantify, mitigate or disclose these very real potential impacts of the proposed project. The EIS/R must be revised and recirculated to address these material omissions and deficiencies in the document. 193

Land Use and Agriculture

- Improved irrigation management and scheduling as a water conservation measure should have been included as a component to some of the alternatives. 194
- The timing and method of vegetation removal was not adequately defined in the EIS/R to ensure water conservation. As an example a previous comment alluded to, Bouldin Island vegetation management was very late, so much of what was supposed to be conserved was not. The EIS/R has failed to provide descriptions, process, monitoring and contingency plans to guarantee idled crop land does not continue to transpire and use water that was supposed to be conserved. 195
- Long term transfers conflict with Williamson Act conservation as long term fallowed ground with no vegetation is no longer agriculture. 196
- Transfers include water conserved from “crop shifting”. If a grower was to plant alfalfa (very water consumptive use intensive) and then they say they will take that crop out and plant winter wheat instead and sell the water that was “saved” by not continuing to grow the water use intensive crop, it opens the whole project to gaming and false water savings. 197

- “Cropland idling water transfers could permanently or substantially decrease the amount of lands categorized as Prime Farmland, Farmland of Statewide Importance, or Unique Farmland under the FMMP.” was determined in the EIS/R to be a Less Than Significant impact for alternative 2. This is an error as irrigation of the land is a core requirement of the definition of “prime farmland”. The proposed project and alternatives take irrigation water away from as much as 177,000 acres in any alternative that includes land fallowing. Alternative 2 includes land fallowing, so it is a significant impact. Alternative 2 may have less of this impact than alternative 4, but it is still significant and must be mitigated.
- The EIS/R fails to identify increased weed pressure on properties adjacent to fallowed fields. This results in additional herbicide applications being required, which has environmental impacts and costs for the adjacent land owner. The EIS/R must be revised to identify, characterize, evaluate, quantify, mitigate and disclose this impact.
- Native grasses and herbaceous plants are slow to colonize highly disturbed soils such as idled agricultural fields so the idled fields are primarily initially colonized by exotic and invasive weed species. The EIS/R failed to identify that the proposed project and alternatives operations would increase weed pressure of exotic and invasive plant species. These exotic and invasive plants also alter habitat value for foraging and refuge for wildlife.
- The EIS/R failed to analyze proposed project impacts on the suitability of water temperatures for agricultural irrigation beneficial uses. The proposed project increased reservoir releases and tributary flows which result in reduced water temperatures farther downstream which in turn results in increased coldwater impacts on crops. DWR’s Oroville Facilities reached a settlement agreement with the water districts which are affected by water temperatures being too cold for crop production. The settlement agreement has resulted in more than a million dollars per year in compensation to the affected growers. The proposed project operations at Oroville would add to these impacts. Similarly, cold water affects from releases from Shasta reservoir for the project, could precipitate impacts for growers that divert water at TCID and GCID. The EIS/R failed to identify, evaluate, quantify, mitigate or disclose coldwater affect impacts to agricultural irrigation beneficial uses resulting from the Proposed Project or alternatives.
- The water transfers must be restricted to avoid inducement of more permanent demand such as conversion of annual crops to permanent crops in the buyer service areas. The EIS/R failed to addressed the impacts of the water transfers in conversion of crop land to permanent crops and development of permanent demand as a result of the project.
- Fields adjacent and downwind of fallowed fields have yield losses from hot dry and dusty air being blown from the bare fields. This impact was not addressed in the EIS/R.
- Vegetation removal from Bouldin Island was required for a water transfer to Semitropic Water District in 2014. The herbicide application resulted in the damage to 10s of thousands of acres of agricultural crops. In this case the crop damage included large portions of the Lodi wine grape district. This spray drift damage has been well documented and publicized (<http://wineindustryinsight.com/?p=54211>, <http://www.winebusiness.com/blog/?go=getBlogEntry&dataId=135322>,

198

199

200

201

202

203

204

http://www.lodinews.com/news/article_3c58d352-f196-11e3-8efa-0019bb2963f4.html, http://rivernewsherald.org/articles2014/bouldin_8-6-2014.html) and is estimated to have caused as much as \$1Billion in damages. Bouldin Island is only 5,900 acres. The proposed project could idle as much as 177,000 acres in a year if it utilized its maximum transfer capacity covered under the EIS/R using mostly the crop idling strategy component of its proposed project water conservation. If the transfers were maximized for the 10 year project period and utilized mostly crop idling as its water conservation strategy then over the 10 year project period, there would be as many as 1,770,000 acres that required herbicide treatment. If only 1% of the herbicide treatments for the proposed project water transfers go as badly as the Bouldin Island water transfer, the impact of these water transfers could be \$3 Billion in damages. If you look at the amount of herbicide damage claims associated with water transfer vegetation removal to date, you will find the damage rate is well above 1%. Just talk to some Forensic Agronomists in California that deal with these types herbicide drift cases (e.g. Rush Markroft, Whaley and Stienberg, Bahme and Associates) to get a realistic rate of damages which occur. DWR has a particularly bad track record (probably among the worst in the state when compared to the amount of damages vs. the number of herbicide applied acres) when it comes to damages to third parties from herbicide applications. If the project claims that some or most of the water conservation will not come from crop idling that require herbicide spray weed control, then they must define these limits and analyze and disclose them in the EIS/R. Previous water transfers have proven that herbicide spray drift is a real risk of this type of project and these risks must be evaluated. The EIS/R failed to identify, characterize, evaluate, quantify, mitigate or disclose these very real potential impacts of the proposed project. The EIS/R must be revised and recirculated to address these material omissions and deficiencies in the document.

204

Cultural

- The impact criteria for cultural resources are incorrect. It is not an impact only if the reservoir levels are drawn down below historical levels, it is an impact if the reservoir drawdown from proposed project and alternatives operations that result in an increase of the frequency and magnitude of archaeological site exposure within the fluctuation zone of the reservoirs. Any increase in the frequency or magnitude of exposure of cultural or archaeological resources is a significant impact of the project. As an example of a correct impact criteria for this resource in a similar environmental document, see the Cultural Resources reports from the California Department of Water Resources Oroville Facilities Relicensing.

205

Recreation

- The impact calls related to reservoir recreation are incorrect. If the proposed project or alternatives result in an increase in the frequency or earlier calendar date of boat ramp dewatering, then the impact is significant and must be mitigated. As an example of a correct impact criteria for this resource in a similar environmental document, see the Recreation

206

Resources reports from the California Department of Water Resources Oroville Facilities Relicensing.

206

Power

- The EIS/R misses the main impact of the proposed project and alternatives 2 and 4 in the impact of increased energy demand from groundwater pumping and from groundwater level drawdown. The amount of groundwater pumping the project can create definitely could be a significant impact to power resources in northern California, especially with power transmission line capacity constraints in the areas where the groundwater power demand can be anticipated. Additionally, “backed up reservoir” water transfers which are include in the proposed project and all alternatives alter the timing and location (see related comments) of hydroelectric power generation associated with these releases as compared to the No Action/No Project. The EIS/R failed to consider these power generation timing and location, changes in location and timing of power consumption and constraints and impacts on power transmission from the proposed project and alternatives. The EIS/R must be revised to correct these omissions and propose mitigations for these undisclosed significant impacts.

207

Flood Control

- The impact calls relative to project impacts on reservoir storage are flawed. Reservoirs are multipurpose, including flood control and water supply. Flood control comes first in terms of overriding operations as adequate flood control reserve must be managed in the flood control season. If the reservoirs are lower due to proposed project operations, there is no impact to flood control operations as flood control reserve releases are less likely to be triggered and therefore the project has no impact. If flood control reserve releases are activated when the reservoir is fuller due to proposed project operations, the water stored by the project will be spilled first.

208

Regional Economics

- “Water transfers from idling alfalfa could increase costs for dairy and other livestock feed.” This impact category misses the fact that alfalfa would be one of the primary crops not grown in the component of the proposed project for “crop shifting”. When rotation away from water use intensive forage crops in crop shifting is added to the loss of these crop acres in the following part of the proposed project and alternatives, the impact to forage supplies and feed prices to local dairies the impacts could be significant.
- The EIS/R does not disclose if the water transfers are paying proportionate fees for conveyance as the water districts that are paying for the SWP and CVP facilities construction and operations.
- Vegetation removal from Bouldin Island was required for a water transfer in 2014. The use of an unregistered combination of herbicides and misapplication of them has resulted in the damage to 10s of thousands of acres of agricultural crops. In this case the habitat damage

209

210

211

included critical habitat for giant garter snake, riparian brush rabbit and rat, tiger salamander, greater sandhill crane, San Joaquin steelhead and Chinook salmon, green sturgeon, delta smelt and other special status species. This spray drift damage has been well documented and publicized (<http://wineindustryinsight.com/?p=54211>, <http://www.winebusiness.com/blog/?go=getBlogEntry&dataId=135322>, http://www.lodinews.com/news/article_3c58d352-f196-11e3-8efa-0019bb2963f4.html, http://rivernewsheald.org/articles2014/bouldin_8-6-2014.html) and is estimated to have caused as much as \$1Billion in damages. Bouldin Island is only 5,900 acres. The proposed project could idle as much as 177,000 acres in a year if it utilized its maximum transfer capacity covered under the EIS/R using mostly the crop idling strategy component of its proposed project water conservation. If the transfers were maximized for the 10 year project period and utilized mostly crop idling as its water conservation strategy then over the 10 year project period, there would be as many as 1,770,000 acres that required herbicide treatment. If only 1% of the herbicide treatments for the proposed project water transfers go as badly as the Bouldin Island water transfer, the impact of these water transfers could be \$3 Billion in damages. Previous water transfers have proven that this is a real risk of this type of project and these risks must be evaluated and \$3 billion in damages to the crops in the seller service areas from the project is a substantial impact to the agricultural industry and local economies that the EIS/R failed to evaluate. The EIS/R failed to identify, characterize, evaluate, quantify, mitigate or disclose these very real potential impacts of the proposed project. The EIS/R must be revised and recirculated to address these material omissions and deficiencies in the document.

211

Environmental Justice

- Fallowed ground and shifting to lower water use intensive crops which are typically less labor intensive than more water intensive crops has significant impacts on disadvantaged local communities, employment opportunities, the working poor, and minority farm workers. Regional economics identifies that 500 people would lose their jobs in the water sellers area from fallowing and crop shifting. The vast majority of these people would be minorities. The EIS/R impact call of “No disproportionately high or adverse effect” is not only incorrect, it is not even a proper NEPA or CEQA impact call.

212

Growth inducement

- Growth inducement was not a section included in the ES summary. Growth inducement consideration is a NEPA requirement.
- These water transfers result in an increase of the economic disparity between the value of water used for agriculture vs. M&I uses. M&I water uses can justify costs in excess of a thousand \$ per acre foot. Almost no crops can be economically grown at a comparable cost to the values that can be justified for M&I uses. The proposed project water transfers inducement creation of permanent demand such as for industrial, urban, commercial or permanent crop use because those water uses can always afford to pay more than the value of the water if it were used for normal row crop production. Therefore, creation of this long

213

214

term water transfer opportunity from the project has significant growth inducement impact from permanent shifting of water use location and beneficial use that must be evaluated, quantified, mitigated and disclosed by the project. The EIS/R must not be approved until these material deficiencies in how it addresses growth inducing impacts are rectified.

214

- Long-term transfers resulting from this project encourage reliance on this water supply. Annual transfers as an alternative for comparison do not. This difference in growth inducement must be evaluated.

215

Cumulative

- The EIS/R analysis must be specific as to each transfer and cumulatively. This cumulative analysis must be in conjunction with single year water transfers and other long-term transfers such as the Lower Yuba River Accord.

216

December 1, 2014

BY U.S. MAIL AND EMAIL

[BHUBBARD@USBR.GOV; FRANCES.MIZUNO@SLDMWA.ORG]



DIRECTORS

**Dan Flory
President**

Antelope Valley-East Kern
Water Agency

**Ray Stokes
Vice President**
Central Coast Water
Authority

**Douglas Headrick
Secretary-Treasurer**
San Bernardino Valley MWD

Stephen Arakawa
Metropolitan Water District
of Southern California

Curtis Creel
Kern County Water Agency

Mark Gilkey
Tulare Lake Basin Water
Storage District

Cindy Kao
Santa Clara Valley Water
District

Dan Masnada
Castaic Lake Water Agency

David Okita
Solano County Water Agency

General Manager
Terry Erlewine

Mr. Brad Hubbard, Project Manager
Bureau of Reclamation
2800 Cottage Way
Sacramento, CA 95825

Ms. Frances Mizuno, Assistant Executive Director
San Luis & Delta-Mendota Water Authority
P.O. Box 2157
Los Baños, CA 93635

Re: State Water Contractors' Comments on Draft Environmental
Impact Statement/Environmental Impact Report for Long-
Term Water Transfers

Dear Mr. Hubbard and Ms. Mizuno:

The State Water Contractors ("SWC") appreciate the opportunity to review and comment on the Draft Environmental Impact Statement/Environmental Impact Report ("EIS/EIR") prepared by the Bureau of Reclamation ("Reclamation") and the San Luis & Delta-Mendota Water Authority ("SLDMWA") for the proposed Long-Term Water Transfers Project (the "Project"). The SWC understand that Reclamation is serving as the lead agency under the National Environmental Policy Act ("NEPA") and that SLDMWA is serving as the lead agency under the California Environmental Quality Act ("CEQA"). These comments are provided by the SWC for both NEPA and CEQA.

As Reclamation and SLDMWA know, the SWC is a nonprofit mutual benefit corporation that represents and protects the common interests of its 27 members¹ in California's State Water Project ("SWP"). Collectively, the SWC member agencies utilize the SWP and other facilities to deliver water to more than 26 million residents throughout the state and to more than 750,000 acres of agricultural lands. Hence, the SWC have an interest in any project that may impact SWP water supplies.

¹ The SWC members agencies are: Alameda County Flood Control and Water Conservation District Zone 7; Alameda County Water District; Antelope Valley-East Kern Water Agency; Casitas Municipal Water District; Castaic Lake Water Agency; Central Coastal Water Authority; City of Yuba City; Coachella Valley Water District; County of Kings; Crestline-Lake Arrowhead Water Agency; Desert Water Agency; Dudley Ridge Water District; Empire-West Side Irrigation District; Kern County Water Agency; Littlerock Creek Irrigation District; Metropolitan Water District of Southern California; Mojave Water Agency; Napa County Flood Control and Water Conservation District; Oak Flat Water District; Palmdale Water District; San Bernardino Valley Municipal Water District; San Gabriel Valley Municipal Water District; San Geronio Pass Water Agency; San Luis Obispo County Flood Control & Water Conservation District; Santa Clara Valley Water District; Solano County Water Agency; and Tulare Lake Basin Water Storage District.

Brad Hubbard, Bureau of Reclamation
 Frances Mizuno, San Luis & Delta-Mendota Water Authority
 December 1, 2014
 Page 2

As described in the EIS/EIR, the Project covers a 10-year period (2015 through 2024) during which water could be transferred between willing sellers and buyers through groundwater substitution, reservoir release, conservation, and other mechanisms. More specifically, the Project would allow Central Valley Project (“CVP”) contractors in areas south of the Delta or in the San Francisco Bay area to purchase transferred water. The transferred water would be conveyed to the purchasers by the sellers through the Delta using existing CVP or SWP facilities and pumps.

1

After reviewing the EIS/EIR, the SWC have several questions regarding the Project and its environmental analysis. Accordingly, the SWC respectfully request that Reclamation and SLDMWA provide further discussion regarding the items identified below in order to more fully comply with NEPA, CEQA, and those laws’ respective public disclosure and analysis requirements. Specifically, the SWC’s questions relate primarily to the analysis of, and mitigation for, potential impacts associated with the Project’s groundwater substitution and reservoir re-operation elements.

1. The SWC request that Reclamation and SLDMWA clarify the criteria for assessing the magnitude of impacts.

Based on the SWC’s review of the EIS/EIR, it is unclear how thresholds of significance or magnitudes of impacts were utilized to determine whether the Project would result in significant impacts to water supplies. The SWC request that the EIS/EIR be clarified to identify with greater specificity how thresholds were applied in both the groundwater substitution and reservoir re-operation contexts, and what specific magnitude of impacts were used when arriving at a significance conclusion.

2

Similarly, when determining whether the Project would result in significant impacts to groundwater resources as a result of groundwater substitution, the EIS/EIR asks whether the Project would cause “[a] net reduction in groundwater levels that would result in adverse environmental effects or effects to non-transferring parties.” (EIS/EIR, p. 3.3-61). Thus, the threshold suggests that any net reduction in groundwater levels or any effect to non-transferring parties (regardless how small) may be significant. The SWC request that the EIS/EIR more clearly identify what standard/magnitude of impact was used for assessing significance. Similarly, the threshold asks whether the Project would result in “adverse environmental effects.” The SWC’s request clarification regarding how “adverse environmental effects” were assessed and what magnitude of impact was used when reaching the significance conclusions in the EIS/EIR.

3

Finally, the EIS/EIR could avoid ambiguities by answering the following questions. Is any amount of “permanent land subsidence” considered significant, and how did Reclamation and SLDMWA determine whether “significant groundwater level declines” would occur in the first instance? (See second threshold at EIS/EIR, p. 3.3-61; see also third threshold which appears to be incomplete at EIS/EIR, p. 3.3-61). The SWC request that the EIS/EIR be clarified to more specifically identify how Reclamation and SLDMWA determined the significance/magnitude of Project impacts.

4

2. The SWC request that Reclamation and SLDMWA expand the analysis of impacts and also clarify the “Environmental Commitments” and Project features that are relied upon to prevent impacts from arising.

- a. The SWC request a further elaboration on the Project’s impacts on water supply and surface/groundwater interactions

5

The discussion of water supply impacts and surface/groundwater interaction confirms the Project’s groundwater substitutions will cause reduced Delta Pumping Station exports on an annual basis. (EIS/EIR, p. 3.1-17). However, it is unclear how those reductions were calculated or during which

Brad Hubbard, Bureau of Reclamation
 Frances Mizuno, San Luis & Delta-Mendota Water Authority
 December 1, 2014
 Page 3

specific months of the year they are likely to arise. As the EIS/EIR notes, the Biological Opinions (“BiOps”) applicable to the Coordinated Operations of the CVP and SWP typically limit the bulk of Delta exports to the months of July through September. (EIS/EIR, pp. ES-9, 1-11). Accordingly, if Project-induced reductions in exports are all concentrated within a narrow-window (particularly during summertime peak exports), the overall impact on water supply may be disproportionately large. The SWC request clarification regarding what month(s) reductions in exports are likely to occur and what impacts to water supply exports may result.

5

Similarly, the SWC request further discussion regarding the groundwater substitutions. Specifically, the SWC request explanation of which specific surface flows are likely to see the largest flow reductions; when those flow reductions are most likely to manifest; and what the magnitude of those reduced volumes may be. As the EIR acknowledges throughout Section 3.3, the geographic area covered by the Project is large and it hosts a wide variety of hydrological and geologic conditions (annual rainfall, volume of groundwater basin, depth to groundwater, etc.). These varying conditions presumably make certain surface flows more vulnerable to the effects of groundwater substitution impacts than others. (See EIS/EIR, p. 3.1-16 [Figure 3.1-2]). Thus, the EIS/EIR should provide a stream-by-stream discussion of whether flow reductions are likely; when those reductions are likely to arise; and what the magnitude of those reductions may be. As described below, mitigation could then be tailored to more specifically address those impacts.

6

The EIS/EIR also confirms that reservoir re-operations will cause a drawdown in reservoir levels. (EIS/EIR, p. 3.1-19). It is anticipated that this drawdown volume would, over time, be replaced by water that would otherwise flow downstream. (EIS/EIR, p. 3.1-18). However, and again as the EIS/EIR alludes to, there are certain flow and salinity requirements arising from the BiOps that regulate Delta exports. If water that would normally flow downstream and assist in meeting BiOp requirements is now withheld in upstream reservoirs (for example, flows that would normally enter the Delta from the San Joaquin River), that could reduce the SWC’s ability to export water from the Delta, an impact that should be described in greater specificity in the EIS/EIR.

7

The EIS/EIR also states that reservoir re-operations may result in reservoir drawdowns that require more than one season to refill. (EIS/EIR, p. ES-11). It is unclear how refill would occur, if at all, in periods of multiple drought years akin to the drought conditions that exist today. Ultimately, the SWC request that the EIS/EIR discuss in greater detail how compliance with the BiOps’ flow requirements, water quality requirements (such as salinity targets), and release timing requirements would be affected by reservoir re-operations.

8

With regard to cumulative impacts, the SWC request clarification of the discussion regarding groundwater substitution and reservoir re-operation. The EIS/EIR confirms that the cumulative effects analysis spans a ten year period (2014-2024). (EIS/EIR, p. 3.3-91). However, elsewhere the EIS/EIR states that residual reservoir drawdowns and stream flow effects may linger for more than one season, potentially even after any transfers have been completed. The SWC request further discussion to confirm that the Project’s impacts have been captured, including those impacts that may remain even after the 10-year transfer period has concluded. Additionally, it is unclear how the cumulative impacts analysis accounts for the combined pressures of existing CVP and SWP operations, the ongoing drought, the potential effects of BiOps, and other projects. The SWC request that an expanded discussion of those issues be provided.

9

- b. The SWC request that “Environmental Commitments” and Project features be further specified.

10

Brad Hubbard, Bureau of Reclamation
 Frances Mizuno, San Luis & Delta-Mendota Water Authority
 December 1, 2014
 Page 4

The EIS/EIR puts forward a number of measures intended to prevent water supply impacts from occurring. The SWC appreciate those efforts, and agree that proactive management is appropriate to prevent impacts from arising. However, the SWC believe that the proposal could be improved with more specific details of those measures specified as part of the current EIS/EIR process.

10

As one example, all transfers (including both groundwater substitution and reservoir re-operation) are subject to a “carriage water” requirement that is aimed at maintaining water quality in the Delta. (EIS/EIR, p. 2-29). It is unclear if this carriage water factors is intended to be duplicative of the stream flow depletion requirement imposed by Mitigation Measure WS-1, or if the carriage water concept is an entirely separate and distinct requirement.

As another example, the EIS/EIR states that all reservoir re-operation transfers would be subject to a “refill agreement” between the seller and Reclamation to prevent impacts to downstream users. (EIS/EIR, p. 2-11). However, it is unclear how quickly refill would be required or how such an agreement would be enforced. Likewise, the EIS/EIR states that the refill agreements would require refill of reservoirs only when it would not adversely affect downstream water users.” (EIS/EIR, p. 3.1-19). It is unclear to the SWC what standards apply for making that determination and which party (the seller, the buyer, the downstream water user, or DWR/Reclamation) would have the burden to prove or disprove any adverse impact. The SWC request clarification of the specific performance standards and enforcement mechanisms for the refill agreements, such as withholding water to refill reservoirs only occurs during times when Delta water exports are not occurring.

11

The EIS/EIR also confirms that Delta water quality may be adversely impacted by reduced flows or changed timing of flows. Thus, “Reclamation and DWR would need to either decrease Delta exports or release additional flow from upstream reservoirs to meet flow or water quality standards.” (EIS/EIR, p. 3.1-16). The SWC request further details on how this Reclamation/DWR process would be implemented; which entity would bear responsibility for documenting the decision; and what factors Reclamation and DWR anticipate applying in deciding whether to cut water supply exports or release upstream reservoir volumes. Similarly, the SWC request elaboration on whether upstream reservoir volumes are likely to be available, particularly as the EIS/EIR elsewhere confirms that total reservoir volume is likely to decrease for more than one season at a time. (See EIS/EIR, p. ES-11).

12

Finally, the EIS/EIR states that transferred water would only be used to meet existing needs and not future or expanded needs. (EIS/EIR, pp. ES-1, 1-1). The SWC request elaboration on how this Project feature will be monitored to ensure that no unanticipated impacts will arise.

13

3. The SWC request that Reclamation and SLDMWA clarify the mitigation to ensure performance with specific criteria.

Here – separate and apart from the “Environmental Commitments” and Project feature concerns addressed above – the SWC believe Mitigation Measure WS-1 requires the implementation of a stream flow depletion factor, which will be developed at a future date and subject to change, and which will be designed to offset any water supply impacts and prevent conflict with the “no injury” rule that may otherwise arise from groundwater substitution transfers. (EIS/EIR, p. 3.1-21). However, measure WS-1 does not identify what specific minimum depletion factor would be required. Instead, it appears that this decision is left largely to DWR and Reclamation’s future discretion. The SWC request further elaboration on how this factor would be developed and enforced, and the SWC recommend that a minimum stream flow depletion factor percentage be established now as part of the current EIS/EIR process.

14

Brad Hubbard, Bureau of Reclamation
 Frances Mizuno, San Luis & Delta-Mendota Water Authority
 December 1, 2014
 Page 5

Likewise, measure WS-1 provides that the stream flow depletion factor will be established “in consultation with buyers and sellers.” (EIS/EIR, p. 3.1-21). However, many of the entities that may suffer injury as a result of any approved transfer are actually downstream water recipients that are neither the buyer nor the seller in the transfer. Thus, the SWC request that measure WS-1 be modified to state that any depletion factor will only be established in consultation with buyers, seller, and other potentially affected parties.

15

Further, measure WS-1 states that no water transfer will be approved if it violates the “no injury rule.” (EIS/EIR, p. 3.1-21). The SWC request that the Mitigation Measure be revised to elaborate on who bears the burden of proving/disproving injury, and what information would be relevant to that determination.

16

Similarly, the SWC request that Mitigation Measure GW-1 be revised to further explain how long-term decreases in surface flows will be prevented or mitigated. As set forth above, the EIS/EIR confirms that surface flows may decrease as a result of increased groundwater pumping. The EIS/EIR confirms that surface flows may experience some decrease over baseline conditions as groundwater basins subsequently recharge. Without further details, it appears that surface water flows may be decreased for a period of 10+ continuous years as transfers result in an ongoing tradeoff between groundwater pumping and groundwater recharge (both of which would reduce flows in surface stream). Thus, the SWC would appreciate further explanation of how Mitigation Measure GW-1 will prevent that long-term reduction in surface flows from occurring. One recommendation is to provide a body-by-body performance standard that states how much reduction in surface water flows would be allowed and over what time period in order to assure that no significant impacts result.

17

In conclusion, the SWC thank Reclamation and the SLDMWA for the opportunity to review and comment upon the EIS/EIR. The SWC appreciate the Project’s overall goal of increasing flexibility and reliability with regard to management of CVP water supplies. However, the SWC do request that Reclamation and SLDMWA expand on the issues identified above in order to comply with CEQA and NEPA. SWC believe it is necessary to provide a fuller and more complete environmental analysis under NEPA and CEQA to help ensure that the Project does not provide a benefit to certain water providers to the potential detriment of others.

Should you have any questions, please do not hesitate to contact me at (916) 447-7357 ext. 203.

Sincerely,

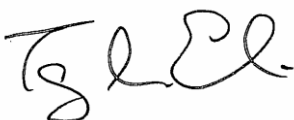

Terry Erlewine
 General Manager



COUNTY OF YOLO

Office of the County Administrator

Patrick S. Blacklock
County Administrator

625 Court Street, Room 202 Woodland, CA 95695
(530) 666-8150 FAX (530) 668-4029
www.yolocounty.org

December 1, 2014

Brad Hubbard
United States Bureau of Reclamation
2800 Cottage Way, MP-410
Sacramento, CA 95825

Frances Mizuno
San Luis and Delta-Mendota Water Authority
P.O. Box 2157
Los Banos, CA 93635

Re: Comments on Draft EIS/EIR on Proposed Long-Term Water Transfers

Dear Mr. Hubbard and Ms. Mizuno:

The County of Yolo ("County") submits this letter to provide its initial comments on the Long Term Water Transfers Draft Environmental Impact Statement/Environmental Impact Report ("Draft EIS/EIR"). The County is continuing to review the Draft EIS and may submit further comments in early 2015.

Altogether, the Executive Summary of the Draft EIS/EIR indicates that up to 86,000 acre-feet of surface water could be transferred each year from 2015 through 2024 from properties within Yolo County to buyers in the San Luis & Delta-Mendota Water Agency ("SLDMA") service area, as well as the Contra Costa Water District and East Bay Municipal Utility District. The County's comments focus on proposed transfers within Yolo County and, in particular, on the potential transfer of up to 35,000 acre-feet annually ("af/yr") from Conaway Ranch. Notwithstanding this letter's focus on transfers from Yolo County, however, the following comments apply equally to other proposed transfers and the Draft EIS/EIR generally.

1. General Comments.

As an overall matter, the County disagrees with the conclusion that Alternative 2 (the "Proposed Action" analyzed in the Draft EIS/EIR) will not have any significant, unavoidable adverse effects. Even considering the "environmental commitments" described in Chapter 2 of the Draft EIR/EIS, it is objectively unreasonable to conclude that the potential transfer of slightly over 500,000 af/yr and associated groundwater substitutions, cropland idling, and other measures within the selling areas will somehow not cause any significant, unavoidable adverse effects. There are a host of specific reasons why this conclusion is inappropriate, including an overreliance on assumptions that lack a sound evidentiary basis and other factors discussed in the following section of this letter.

Altogether, these analytical flaws distort the comparison of the Proposed Action to other alternatives that could reduce environmental effects associated with cropland idling (Alternative 3) and groundwater substitutions (Alternative 4). The deficient analysis of the Proposed Action's environmental effects compromises the analysis of Alternatives 3 and 4, as well as the ultimate conclusion that those alternatives are not "environmentally superior"

to the Proposed Action. The timeframe for analysis—a ten-year period between 2015 and 2024—is also artificial and appears to have been contrived for the purpose of environmental analysis, independent of any proposed transactions or other relevant factors. A shorter transactional timeframe (such as five years) should be used to ensure that environmental effects are appropriately studied as they become apparent, rather than dismissed several years from now by virtue of the inappropriate use of a ten-year period in the Draft EIS/EIR.

These fundamental flaws in the Draft EIS/EIR are alone sufficient to support revising the document in several respects, as noted more specifically below. The Draft EIS/EIR should also be recirculated for further public review after these deficiencies are addressed.

2. Issue-Specific Comments.

The County's specific comments fall into three categories: (A) subsidence and public safety; (B) agricultural and economic impacts; (C) impacts on terrestrial species, including migratory waterfowl.

A. Subsidence and Public Safety.

The Draft EIS/EIR fails (albeit understandably) to consider recent information relating to subsidence on the Conaway Ranch during the Summer of 2014. A copy of the report on subsidence produced by MBK Engineers on November 12, 2014 is attached hereto. As that report documents, portions of the Conaway Ranch subsided by up to 17 centimeters (6.5 inches) in a three-month period. That three-month period coincided with the transfer of about 25,000 af of surface water to the Tehama-Colusa Canal Authority via groundwater substitution.

The County acknowledges that it is not possible to determine the relative contribution of increased groundwater pumping and the fallowing of thousands of acres of farmland on Conaway Ranch to the observed subsidence. However, the overall circumstances support a serious concern that further surface water transfers will cause or contribute to similar effects if up to 35,000 af/year is transferred from Conaway Ranch in the future (in addition to 10,000 af/year that Conaway Preservation Group is contractually obligated to deliver to local cities). This concern is particularly acute because the Yolo Bypass passes through Conaway Ranch. The levees of the Yolo Bypass are already known to suffer from various deficiencies, as documented in the Draft EIR for the Central Valley Flood Protection Plan in 2012 and numerous other public documents. Subsidence can further compromise levee integrity (Draft EIS/EIR at p. 3.3-28) and, in turn, increase public safety risks within Yolo County.

Further analysis is required in the Draft EIS/EIR to determine the potential magnitude of such effects and, in addition, to enable proper consideration of the findings required for surface water transfers by Water Code § 1745.10 (relating to conditions of long-term overdraft in affected groundwater basins). These are serious concerns that deserve specific attention in the Draft EIS/EIR, which should be recirculated after it is revised to include a discussion of the new information available on subsidence within the Conaway Ranch. The potential for adverse short-term subsidence effects should also be considered, as even subsidence of a limited duration could impact levee integrity and increase public safety risks (as well as the environmental consequences of large-scale inundation of urban areas if the Yolo Bypass levees fail).

In addition, Mitigation Measure GW-1 (Monitoring Program and Mitigation Plans) is legally inadequate. By its own terms, it applies only if "substantial adverse impacts" are determined to occur as a consequence of increased groundwater pumping due to surface water transfers. (Draft EIS/EIR at p. 3.3-90.) It assumes, without any apparent basis, that such "substantial adverse impacts" are entirely reversible and can be reduced to a less than significant level through mitigation plans backed by "financial assurances." Much more is needed to explain the conclusion that such mitigation plans will be effective, that adequate financial assurances can be provided (particularly for impacts on major public infrastructure such as levees), and that Mitigation Measure GW-1 is otherwise sufficient in all instances to reduce even the short-term adverse effects of subsidence and other effects of groundwater pumping to a less than significant level. Additionally, the Draft EIS/EIR should study mitigation measures (or project alternatives) that include common-sense approaches such as lower levels of transfers and/or related groundwater pumping.

B. Agricultural and Economic Impacts.

The Executive Summary of the Draft EIS/EIR explains that the proposed transfers are primarily intended to support agriculture within SLDMA boundaries. Ironically however, all of the identified drawbacks of the "no action alternative" in the Draft EIS/EIR—increased groundwater pumping, cropland idling, and land retirement within the SLDMA—could occur within the selling areas if the transfers proceed. These effects range from minor to significant, as explained in Chapter 3.9 of the document.

10

Despite this, the Draft EIS/EIR does not contain sufficient mitigation measures or other constraints upon the proposed transfers to ensure that the adverse effects of water shortages are not simply transferred from the SLDMA to the selling areas. There is no legal or practical reason why this should be so. For instance, the Draft EIR/EIS could easily contain safeguards that limit transfers to the extent necessary to avoid environmentally and/or economically significant effects on groundwater pumping, cropland idling, and land retirement within the selling areas. Such mitigation measures (or project alternatives) should be included for consideration in a recirculated version of the Draft EIS/EIR. More detailed consideration of the potential for Alternatives 3 and 4 to reduce such effects should also be included in the recirculated document.

11

The Draft EIS/EIR also takes an inappropriately narrow view of "agricultural impacts." It focuses largely on whether cropland idling and changes in cropping patterns will "substantially decrease" the amount of affected farmland designated Prime Farmland, Farmland of Statewide Importance, or Unique Farmland during the limited term of the transfer program studied in the Draft EIS/EIR. This impact is deemed less than significant under Alternative 2, primarily because cropland idling will be for relatively short periods of time during the ten-year duration of the studied transfers.

12

This analytical approach is flawed because the water transfers facilitated by the Draft EIS/EIR will lead to continued demand (post-2024) for additional water transfers to support agricultural, municipal, and industrial uses within the boundaries of the SLDMA and other purchasing entities. For this reason, the ten-year term of the environmental analysis is entirely artificial. It has no connection to real-world demands, which will extend long past 2024, nor does it have any apparent connection to legal or other characteristics of the proposed transfers. A short-term view of the environmental and economic effects of creating a water transfer program is therefore inappropriate because it can be seen with reasonable certainty that, analogous to the growth-inducing effects of urban development projects, the demand for such transfers will continue beyond the limited life of the program. The Draft EIS/EIR should be revised to account for the basic reality that water transfers will lead to (and likely increase the demand for) more water transfers, well beyond the ten-year period of the analysis.

13

Finally, the potential adverse economic impacts of the proposed transfers are considerable, particularly within Yolo, Colusa, and Glenn Counties. The Draft EIS/EIR notes that, among other things, over 40,000 acres in rice land alone in the Sacramento Region may not be farmed due to the potential water transfers. In those three counties alone, up to 362 jobs may be lost and the projected declines in labor income and economic output are \$11.1 million and \$45.46 million, respectively.

14

These economic effects (and the related potential for indirect environmental effects) deserve considerably more analysis. To use one example, the potential decline of rice cultivation in the Yolo Bypass due to water transfers, ecosystem restoration, and other projects (which should be included in an analysis of cumulative impacts) could lead to a "tipping point"—meaning that rice cultivation ceases to be commercially viable even on unaffected lands throughout the County—due to a decline in rice volumes, the resulting closure of local rice mills, and the eventual rise of unit processing costs to unacceptable levels. None of this appears to have received meaningful consideration in the Draft EIS/EIR.

15

C. Impacts on Terrestrial Species, Including Migratory Waterfowl.

The Draft EIS/EIS concludes that potential adverse effects on habitat availability and suitability for terrestrial species due to cropland idling/shifting under Alternatives 2 and 4 would be less than significant. This is simply wrong, particularly (though not only) for species that depend on flooded agricultural fields and associated irrigation waterways. Not only does this analytical shortcoming render the Draft EIS/EIR deficient under the California Environmental Quality Act ("CEQA") and the National Environmental Policy Act ("NEPA"), it also calls into

16

question whether the proposed transfers meet the requirements of the Central Valley Project Improvement Act of 1992 (which prohibits water transfers will adversely affect water supplies for fish and wildlife) and similar provisions of the California Water Code (e.g., Cal. Water Code §§ 1725 and 1736).

16

For the giant garter snake, the analysis of these issues in the Draft EIS/EIR is particularly deficient. The analysis at pp. 3-8.68 through 3-8.70 is highly general and simply states the obvious (i.e., that some individual members of the species will be subject to increased predation and other risks due to habitat displacement) before concluding that impacts are unlikely to be significant. The conclusion appears to be nothing more than speculation.

17

Also, the "environmental commitments" described at p. 2-29 are unlikely to be sufficient to protect giant garter snake populations in Yolo County. The commitments primarily limit restrictions on transfers from fields "abutting or immediately adjacent to" the "land side" of the Toe Drain along Willow Slough and Willow Slough Bypass in Yolo County. (Draft EIS/EIS at p. 2-29.) This very narrow restriction that fails to fully account for the wide distribution of the giant garter snake across parcels not immediately adjacent to the Toe Drain. Accordingly, the Draft EIS/EIR does not sufficiently explain how this restriction supports a conclusion that impacts will be less than significant.

18

Similarly troubling is the complete absence of any analysis of the potential effects of the proposed water transfers on the Swainson's hawk or migratory waterfowl. Numerous passages in Chapter 3-8 indicate that the authors of the Draft EIS/EIR understand that agricultural fields and natural communities affected by the proposed transfers currently support abundant Swainson's hawk and migratory waterfowl populations. Despite this, however, there is no meaningful analysis of potential impacts on the Swainson's hawk or migratory waterfowl. Effects resulting from the fallowing of fields--and for migratory waterfowl, particularly the loss of up to 40,000 in rice annually--need to be analyzed carefully in the Draft EIS/EIR.

19

* * *

Overall, as this letter describes, the Draft EIS/EIR needs significant revisions and recirculation to meet the requirements of CEQA and NEPA. The County requests notice of any hearings or other public discussions of the Draft EIS/EIR or the water transfers studied therein, as well as copies of any documents subsequently produced under CEQA or NEPA for the proposed transfers. Such notice is required by CEQA, as the County is a "responsible agency" within the meaning of that statute. As noted above, the County is continuing to review the Draft EIS and may submit further comments in early 2014.

20

Very truly yours,



Patrick S. Blacklock
Yolo County Administrator

Enclosure

cc: Yolo County Board of Supervisors

GILBERT COSIO, JR., P.E.
MARC VAN CAMP, P.E.
WALTER BOUREZ, III, P.E.
RIC REINHARDT, P.E.
GARY KIENLEN, P.E.
DON TRIEU, P.E.
DARREN CORDOVA, P.E.
NATHAN HERSHEY, P.E., P.L.S.
LEE BERGFELD, P.E.

ANGUS NORMAN MURRAY
1913-1985

CONSULTANTS:
JOSEPH I. BURNS, P.E.
DONALD E. KIENLEN, P.E.

November 12, 2014

Richard Woodley
U.S. Bureau of Reclamation
2800 Cottage Way
Sacramento, CA 95821

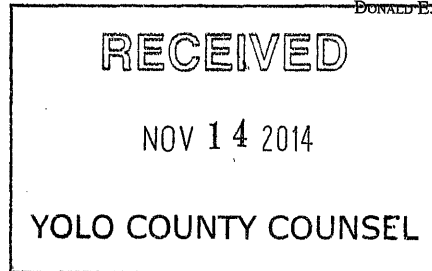

**Subject: Conaway Preservation Group 2014 Water Transfer
Second Land Subsidence Report**

Dear Mr. Woodley:

On behalf of Conaway Preservation Group (CPG), the purpose of this letter is to provide the enclosed Survey Control Project Report (Report) requested pursuant to Paragraph 16 of the Agreement Among the United States, CPG, and the Tehama-Colusa Canal Authority to Provide for Additional Water from the Central Valley Project for 2014, dated May 19, 2014 (Agreement). The Report details the results of a land subsidence monitoring survey conducted at the end of the 2014 irrigation season for CPG by Frame Surveying & Mapping in accordance with the approach identified in Exhibit E to the Agreement. The Report includes a comparison of the survey results with the initial land subsidence survey results transmitted to your office by letter dated August 28, 2014. A third land subsidence monitoring survey will be conducted prior to the start of the 2015 irrigation season; and following that survey, the results will be documented in a report to be provided in a future update pursuant to Exhibit E.

Please call if you have any questions or require additional information.

Sincerely,
MBK ENGINEERS

A handwritten signature in black ink that reads "Darren Cordova".

Darren Cordova

Enclosures

cc: Robert Thomas, Conaway Preservation Group
Regina Cherovsky, Conaway Preservation Group
Mike Hall, Conaway Preservation Group
Andrew Hitchings, Somach, Simmons & Dunn
Tim Durbin, Tim J. Durbin, Inc.
Jim Frame, Frame Surveying & Mapping
Jeff Sutton, Tehama-Colusa Canal Authority
Sheri Looper, U.S. Bureau of Reclamation
Stanley Parrott, U.S. Bureau of Reclamation
Trevor Joseph, Department of Water Resources
Chris Bonds, Department of Water Resources
Philip Pogledich, Yolo County Counsel
Tim O'Halloran, Yolo County FC&WCD



FRAME SURVEYING & MAPPING
609 A Street Davis, CA 95616
530.756.8584 jhframe@dcn.org

AQUA-266C

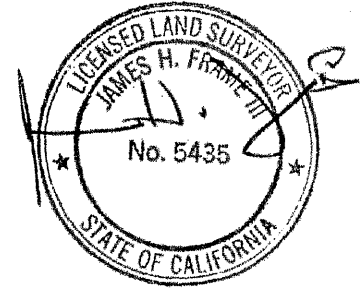

SURVEY CONTROL PROJECT REPORT

CONAWAY RANCH LAND SUBSIDENCE MONITORING
SEPTEMBER, 2014 MONITORING EVENT

PURPOSE

This report describes the results of the second monitoring event of the Conaway Ranch subsidence monitoring project. The initial (baseline) measurements were described in a June, 2014 report, which is a companion document to this report.

EXECUTIVE SUMMARY

Of the 10 monitoring stations within the immediate project area, measurable subsidence was detected at 6 of the stations. The measured subsidence ranged from 5 cm to 17 cm, with the largest value found at station SM10, which is located near the ranch headquarters and also near the DWR extensometer. Estimated measurement accuracy is 2 cm. See Appendix A for a graphical approximation of subsidence distribution.

MONITORING EVENT DESIGN

As with the June measurements, the September monitoring event consisted of 30-minute minimum GPS observation sessions at all monitored stations. OPUS Projects was used to establish current ellipsoid heights at 8 stations in and near the project area.

The only terrestrial measurement in the September event was a trig leveling check between SM10 and the nearby EX11, which was performed in response to the relatively large movement detected at SM10. It was determined that EX11 had subsided 0.016 m less than SM10. The June measurements to FERR and CONA were made to tie the project to the Yolo Subsidence Network, but aren't considered necessary to the ongoing monitoring effort.

DATA PROCESSING AND ADJUSTMENT

Substantially duplicating the process followed in June, GPS data files greater than 2 hours in length were processed in OPUS Projects, and the resulting adjustment again constrained stations LNC2, P267, P268 and SACR. The ellipsoid heights of the constraining stations showed very little change between the June and September events – 5 mm or less – validating the selection of these stations as stable vertical constraints.

TABLE E			
STATION POSITIONS - CCS83 US SURVEY FEET			
STATION	NORTHING	EASTING	ELEVATION
1031	2008599.383	6644606.877	33.236
CAST	1967456.543	6663504.495	17.005
COD1	1977287.674	6659463.132	21.206
COY1	1977246.445	6649648.950	27.478
CR27	1987259.421	6648517.853	29.651
EX11	1997336.718	6656626.527	24.513
P268	1934465.509	6662900.456	25.804
P271	2001341.660	6643182.771	42.554
RIVE	1997860.863	6683832.685	39.235
S16A	2008423.129	6663149.765	27.723
SM08	1987046.351	6662905.689	21.206
SM09	1988144.768	6673466.416	18.500
SM10	1997409.582	6656970.177	30.939
SM11	2006681.702	6655241.391	23.129
UCD1	1957204.975	6632828.912	102.613

HEIGHT COMPARISONS, SEPTEMBER 2014 – JUNE 2014

Table F below shows the difference in station height between the September and June 2014 monitoring events. A negative delta value indicates that a station has subsided.

These values constitute the data from which the subsidence contours shown in Appendix A were developed. Reiterating the cautionary note from Appendix A, these contours are based on interpolating between the very sparse data points available from the survey. While they are useful for showing in broad strokes the distribution of subsidence, they are not to be regarded as accurate except in the immediate vicinity of the individual monitoring stations.

TABLE C			
GEOGRAPHIC STATION POSITIONS			
STATION	LATITUDE	LONGITUDE	ELLIP HT (M)
1031	38-40-38.146911	121-42-34.079974	-20.568
CAST	38-33-50.779180	121-38-37.806580	-25.807
COD1	38-35-28.114860	121-39-28.223014	-24.459
COY1	38-35-28.054244	121-41-31.836450	-22.597
CR27	38-37-07.071749	121-41-45.661002	-21.847
EX11	38-38-46.406630	121-40-03.026719	-23.288
P268	38-28-24.681149	121-38-47.027881	-23.431
P271	38-39-26.447882	121-42-52.326075	-17.804
RIVE	38-38-50.462947	121-34-20.065279	-18.774
S16A	38-40-35.753116	121-38-40.255181	-22.202
SM08	38-37-04.450378	121-38-44.384113	-24.364
SM09	38-37-14.880094	121-36-31.260494	-25.163
SM10	38-38-47.114446	121-39-58.691662	-21.328
SM11	38-40-18.832764	121-40-20.061430	-23.630
UCD1	38-32-10.449924	121-45-04.379784	0.014

TABLE D			
STATION POSITIONS - CCS83 Meters			
STATION	NORTHING	EASTING	ELEVATION
1031	612222.316	2025280.227	10.131
CAST	599681.954	2031040.232	5.183
COD1	602678.488	2029808.422	6.464
COY1	602665.922	2026817.054	8.375
CR27	605717.883	2026472.295	9.038
EX11	608789.449	2028943.823	7.472
P268	589626.267	2030856.121	7.865
P271	610010.158	2024846.158	12.971
RIVE	608949.209	2037236.277	11.959
S16A	612168.594	2030932.110	8.450
SM08	605652.939	2030857.716	6.464
SM09	605987.737	2034076.632	5.639
SM10	608811.658	2029048.568	9.430
SM11	611637.806	2028521.633	7.050
UCD1	596557.269	2021690.296	31.277

accurate depiction of the distribution of that subsidence. If a more precise model of subsidence distribution is desired, the network of monitoring points will need to be densified. This can be accomplished by supplementing the rigorous static GPS network with infill measurements captured by means of more rapid – though slightly less accurate – GPS techniques.

TABLE F			
ORTHOMETRIC HEIGHT COMPARISONS			
SEPTEMBER 2014 - JUNE 2014 (METERS)			
STATION	09/2014	06/2014	Δ ELEVATION
1031	10.131	10.183	-0.053
CAST	5.183	5.170	0.013
COD1	6.464	6.475	-0.012
COY1	8.375	8.414	-0.039
CR27	9.038	9.125	-0.087
EX11	7.472	7.628	-0.156
P268	7.865	7.867	-0.002
P271	12.971	13.023	-0.053
RIVE	11.959	11.983	-0.024
S16A	8.450	8.445	0.004
SM08	6.464	6.471	-0.007
SM09	5.639	5.628	0.011
SM10	9.430	9.602	-0.172
SM11	7.050	7.121	-0.071
UCD1	31.276	31.295	-0.019

DWR EXTENSOMETER DATA, SEPTEMBER – JUNE 2014

Data from the Conaway Extensometer is available at

http://www.water.ca.gov/waterdatalibrary/docs/Hydstra/docs/09N03E08C004M/POR/GROUND_SURFACE_DISPLACEMENT_POINT_DATA.CSV

This data indicates that between June 10, 2014 and September 4, 2014 the ground surface was displaced downward 0.12 m (0.42 foot) at the extensometer site. This substantially corroborates the change in elevation shown in Table F above.

SUMMARY

The orthometric height values determined by this survey have an estimated accuracy of +/- 2 cm at the 95% confidence level. Although many of the 95% error estimates for heights shown in the Star*Net adjustment report (see Appendix D) are smaller by a magnitude, empirical evidence has demonstrated that GPS height transfer is not reliably accurate at that level.

The results of this survey document land subsidence on the Conaway Ranch that occurred during the Summer 2014 season. However, the nature of the monitoring network does not permit

APPENDIX B - OPUS PROJECTS NETWORK ADJUSTMENT REPORT

NGS OPUS-PROJECTS NETWORK ADJUSTMENT REPORT

All coordinate accuracies reported here are 1 times the formal uncertainties from the solution. For additional information:
geodesy.noaa.gov/OPUS/Using_OPUS-Projects.html#accuracy

These positions were computed without any knowledge by the National Geodetic Survey regarding the equipment or field operating procedures used.

SUBMITTED BY: jhframe
 SOLUTION FILE NAME: network-network-20140907-LNC2-P267-P2.sum
 SOLUTION SOFTWARE: GPSCOM(1210.24)
 SOLUTION DATE: 2014-09-07T20:06:48 UTC
 STANDARD ERROR OF UNIT WEIGHT: 0.500
 TOTAL NUMBER OF OBSERVATIONS: 829229
 TOTAL NUMBER OF MARKS: 16
 NUMBER OF CONSTRAINED MARKS: 4

START TIME: 2014-09-03T00:00:00 GPS
 STOP TIME: 2014-09-04T23:59:30 GPS
 FREQUENCY: L1-ONLY TO ION-FREE [BY BASELINE LENGTH]
 OBSERVATION INTERVAL: 30 s
 ELEVATION CUTOFF: 15 deg
 TROPO INTERVAL: 1800 s [STEP-OFFSET PARAMETERIZATION]
 DD CORRELATIONS: ON

INCLUDED SOLUTION	RMS	SOFTWARE	RUN DATE
1) 2014-246 A	1.1 cm	GPSCOM(1210.24)	2014-09-07T19:41 UTC
2) 2014-246 B	1.3 cm	page5(1404.11)	2014-09-07T18:54 UTC
3) 2014-247 A	0.9 cm	GPSCOM(1210.24)	2014-09-07T19:30 UTC
4) 2014-247 B	0.9 cm	GPSCOM(1210.24)	2014-09-07T19:35 UTC

BASELINE	LENGTH	RMS	OBS	OMITTED	FIXED IN SOLUTION(S)
1031-p271	2.254 km	0.4 cm	1566	0.4%	100.0% 1
coy1-cod1	2.992 km	0.5 cm	6924	2.5%	100.0% 2, 3, 4
sm08-cod1	3.154 km	0.6 cm	6951	4.4%	100.0% 2, 3, 4
sm10-sm08	3.640 km	0.6 cm	14526	3.6%	96.9% 1, 2, 3, 4
s16a-sm10	3.849 km	0.5 cm	3397	0.8%	100.0% 1, 4
p271-sm10	4.370 km	0.8 cm	17341	2.2%	100.0% 1, 2, 3, 4
sm08-coy1	5.025 km	0.6 cm	6216	1.4%	100.0% 3, 4
sm10-1031	5.083 km	0.6 cm	1565	0.5%	100.0% 1
s16a-1031	5.652 km	0.5 cm	957	2.6%	100.0% 1
s16a-p271	6.458 km	0.5 cm	1915	0.9%	100.0% 4
sm08-s16a	6.516 km	0.7 cm	3741	2.1%	100.0% 1, 4
coy1-sm10	6.539 km	0.6 cm	6300	0.5%	100.0% 3, 4
sm08-p271	7.425 km	0.9 cm	6409	2.5%	100.0% 1
coy1-p271	7.604 km	0.7 cm	6274	1.0%	100.0% 3, 4
ucd1-coy1	7.975 km	0.9 cm	6270	0.3%	100.0% 3, 4
ucd1-cod1	10.168 km	0.7 cm	2157	3.8%	100.0% 2
ucd1-p268	11.492 km	1.0 cm	57113	0.3%	100.0% 1, 3, 4
ucd1-sm08	12.915 km	1.0 cm	6361	2.5%	100.0% 1
p268-cod1	13.095 km	0.9 cm	7111	2.2%	100.0% 2, 3, 4
coy1-p268	13.651 km	0.9 cm	6310	0.3%	100.0% 3, 4
p271-ucd1	13.819 km	0.9 cm	56921	0.7%	98.8% 1, 3, 4

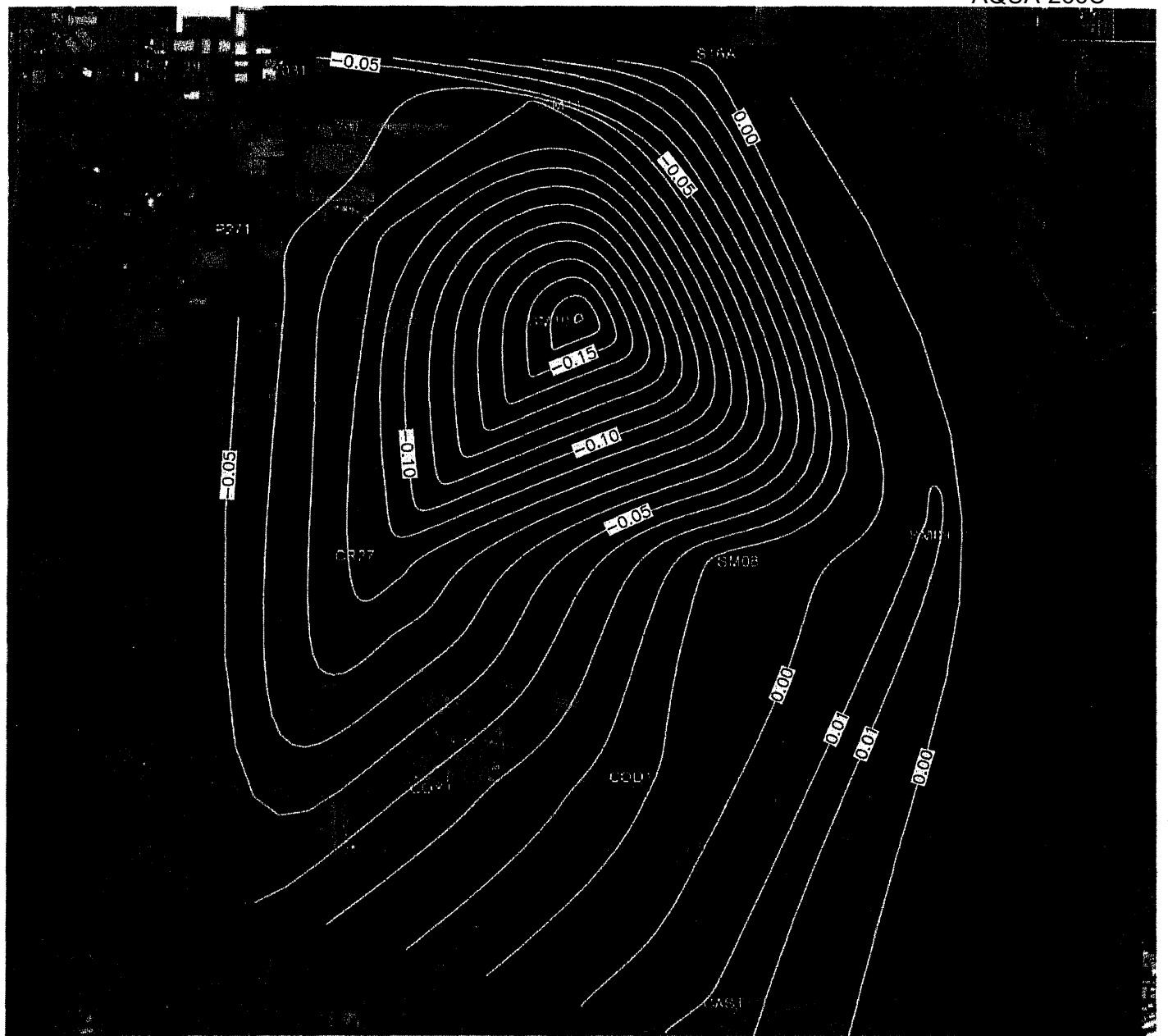

NOTES

1. SUBSIDENCE VALUES REPRESENT MOVEMENT DETECTED BETWEEN JUNE 10, 2014 AND SEPTEMBER 4, 2014.
2. CONTOUR LINES SHOWN WERE DERIVED FROM SPARSE DATA AND ARE INTENDED TO DEPICT APPROXIMATE SUBSIDENCE DISTRIBUTION ONLY EXCEPT IN THE IMMEDIATE VICINITY OF MONITORING STATIONS.
3. ABSOLUTE VALUES SMALLER THAN 0.02 METER ARE NOT CONSIDERED SIGNIFICANT DUE TO THE LIMITS OF THE MEASUREMENT TECHNOLOGY.



FRAME SURVEYING & MAPPING
 609 A STREET DAVIS, CA 95616
 530.756.8584 (v&f) jhframe@dcn.org
 1037-001

SUBSIDENCE CONTOURS
 CONAWAY RANCH SUBSIDENCE MONITORING EVENT
 SEPTEMBER, 2014 SCALE: 1" = 2000'
 SUBSIDENCE VALUES SHOWN IN METERS

APPENDIX B - OPUS PROJECTS NETWORK ADJUSTMENT REPORT

+++++
 UNCONSTRAINED MARKS
 +++++

MARK: 1031 (1031 1)

REF FRAME:	NAD_83(2011) (2010.0000)	IGS08 (2014.6730)
X:	-2620586.835 m 0.002 m	-2620587.718 m 0.002 m
Y:	-4241524.000 m 0.002 m	-4241522.693 m 0.002 m
Z:	3964397.371 m 0.002 m	3964397.344 m 0.002 m
LAT:	38 40 38.14700 0.001 m	38 40 38.15946 0.001 m
E LON:	238 17 25.92000 0.001 m	238 17 25.86048 0.001 m
W LON:	121 42 34.08000 0.001 m	121 42 34.13952 0.001 m
EL HGT:	-20.585 m 0.002 m	-21.108 m 0.002 m
ORTHO HGT:	10.113 m 0.022 m	(H = h - N WHERE N = GEOID12A HGT)

	UTM COORDINATES	STATE PLANE COORDINATES
	UTM (Zone 10)	SPC (0402 CA 2)
NORTHING (Y)	4281753.255 m	612222.319 m
EASTING (X)	612257.527 m	2025280.226 m
CONVERGENCE	0.80658090 deg	0.18317207 deg
POINT SCALE	0.99975518	0.99993980
COMBINED FACTOR	0.99975841	0.99994303

US NATIONAL GRID DESIGNATOR: 10SFH1225781753 (NAD 83)

+++++

MARK: casr (casr a 1)

REF FRAME:	NAD_83(2011) (2010.0000)	IGS08 (2014.6726)
X:	-2705828.432 m 0.001 m	-2705829.321 m 0.001 m
Y:	-4207167.175 m 0.002 m	-4207165.810 m 0.002 m
Z:	3943880.560 m 0.002 m	3943880.595 m 0.002 m
LAT:	38 26 26.41470 0.001 m	38 26 26.42904 0.001 m
E LON:	237 15 10.83511 0.001 m	237 15 10.77384 0.001 m
W LON:	122 44 49.16489 0.001 m	122 44 49.22616 0.001 m
EL HGT:	11.968 m 0.002 m	11.467 m 0.002 m
ORTHO HGT:	43.427 m 0.022 m	(H = h - N WHERE N = GEOID12A HGT)

	UTM COORDINATES	STATE PLANE COORDINATES
	UTM (Zone 10)	SPC (0402 CA 2)
NORTHING (Y)	4254740.503 m	586187.630 m
EASTING (X)	522080.014 m	1934786.767 m
CONVERGENCE	0.15729779 deg	-0.47095370 deg
POINT SCALE	0.99960600	0.99997739
COMBINED FACTOR	0.99960412	0.99997551

US NATIONAL GRID DESIGNATOR: 10SEH2208054740 (NAD 83)

APPENDIX B - OPUS PROJECTS NETWORK ADJUSTMENT REPORT

p268-sm08	16.027 km	1.1 cm	17523	3.3%	100.0%	1, 3, 4
ucd1-p267	18.412 km	1.0 cm	56766	1.0%	100.0%	1, 3, 4
p268-p267	18.585 km	0.9 cm	76118	0.8%	100.0%	1, 2, 3, 4
sacr-lnc2	21.262 km	1.5 cm	35562	3.2%	100.0%	1, 2
s16a-sacr	25.379 km	1.2 cm	1974	3.9%	100.0%	1
sm08-sacr	25.707 km	1.6 cm	11738	3.9%	88.9%	1, 2
lnc2-s16a	31.759 km	0.9 cm	4209	0.8%	100.0%	1, 4
p268-sacr	32.469 km	1.4 cm	17971	2.2%	94.3%	1
lnc2-sm10	35.312 km	1.1 cm	6534	2.5%	100.0%	3
lnc2-sm08	36.090 km	1.1 cm	11122	3.3%	100.0%	3, 4
p271-lnc2	37.975 km	0.9 cm	37938	0.8%	96.3%	3, 4
p267-p261	42.752 km	0.9 cm	37922	1.0%	100.0%	3, 4
p268-lnc2	48.759 km	0.9 cm	38122	0.3%	100.0%	3, 4
p261-ucd1	58.923 km	1.0 cm	37904	0.4%	100.0%	3, 4
lnc2-cho5	70.520 km	1.0 cm	18787	1.3%	96.6%	1
p271-p261	71.169 km	0.9 cm	38068	0.5%	98.2%	3, 4
p267-casr	80.959 km	1.1 cm	18714	1.6%	98.4%	1
p267-s300	82.582 km	0.9 cm	18896	0.7%	98.1%	1
1031-cho5	83.947 km	0.8 cm	1542	1.8%	100.0%	1
cho5-s16a	83.951 km	1.0 cm	2304	0.7%	100.0%	1
casr-ucd1	87.522 km	1.2 cm	18719	1.0%	95.1%	1
s300-p268	89.915 km	0.9 cm	18999	0.3%	100.0%	1
p271-casr	93.160 km	1.2 cm	18686	1.8%	100.0%	1
casr-1031	94.167 km	1.3 cm	1551	0.3%	100.0%	1
sacr-s300	111.173 km	1.4 cm	17897	1.9%	98.4%	1
casr-s300	135.166 km	1.2 cm	18823	0.4%	92.7%	1
cho5-casr	144.661 km	1.3 cm	18515	2.5%	95.7%	1

APPENDIX B - OPUS PROJECTS NETWORK ADJUSTMENT REPORT

+++++

MARK: coy1 (coy1 1)

REF FRAME:	NAD_83(2011) (2010.0000)	IGS08 (2014.6757)
X:	-2622442.280 m 0.001 m	-2622443.163 m 0.001 m
Y:	-4247392.981 m 0.002 m	-4247391.673 m 0.002 m
Z:	3956926.861 m 0.002 m	3956926.834 m 0.002 m
LAT:	38 35 28.05426 0.001 m	38 35 28.06670 0.001 m
E LON:	238 18 28.16354 0.001 m	238 18 28.10409 0.001 m
W LON:	121 41 31.83646 0.001 m	121 41 31.89591 0.001 m
EL HGT:	-22.598 m 0.002 m	-23.122 m 0.002 m
ORTHO HGT:	8.375 m 0.022 m	(H = h - N WHERE N = GEOID12A HGT)

	UTM COORDINATES	STATE PLANE COORDINATES
	UTM (Zone 10)	SPC (0402 CA 2)
NORTHING (Y)	4272215.915 m	602665.922 m
EASTING (X)	613897.797 m	2026817.053 m
CONVERGENCE	0.81585354 deg	0.19407278 deg
POINT SCALE	0.99975975	0.99995154
COMBINED FACTOR	0.99976329	0.99995509

US NATIONAL GRID DESIGNATOR: 10SFH1389772215 (NAD 83)

+++++

MARK: p261 (p261 a 4)

REF FRAME:	NAD_83(2011) (2010.0000)	IGS08 (2014.6753)
X:	-2677432.147 m 0.001 m	-2677433.022 m 0.001 m
Y:	-4248807.523 m 0.002 m	-4248806.186 m 0.002 m
Z:	3918882.060 m 0.002 m	3918882.053 m 0.002 m
LAT:	38 09 10.64359 0.001 m	38 09 10.65673 0.001 m
E LON:	237 46 56.91143 0.001 m	237 46 56.85175 0.001 m
W LON:	122 13 03.08857 0.001 m	122 13 03.14825 0.001 m
EL HGT:	118.692 m 0.002 m	118.166 m 0.002 m
ORTHO HGT:	150.561 m 0.022 m	(H = h - N WHERE N = GEOID12A HGT)

	UTM COORDINATES	STATE PLANE COORDINATES
	UTM (Zone 10)	SPC (0402 CA 2)
NORTHING (Y)	4223075.294 m	554005.247 m
EASTING (X)	568556.824 m	1980933.176 m
CONVERGENCE	0.48340313 deg	-0.13714237 deg
POINT SCALE	0.99965788	1.00004578
COMBINED FACTOR	0.99963926	1.00002716

US NATIONAL GRID DESIGNATOR: 10SEH6855623075 (NAD 83)

APPENDIX B - OPUS PROJECTS NETWORK ADJUSTMENT REPORT

+++++

MARK: cho5 (cho5 a 2)

REF FRAME:	NAD_83(2011) (2010.0000)		IGS08 (2014.6726)	
X:	-2589569.372 m	0.001 m	-2589570.258 m	0.001 m
Y:	-4198613.275 m	0.002 m	-4198611.980 m	0.002 m
Z:	4029540.481 m	0.002 m	4029540.456 m	0.002 m
LAT:	39 25 57.48598	0.001 m	39 25 57.49848	0.001 m
E LON:	238 20 06.18724	0.001 m	238 20 06.12729	0.001 m
W LON:	121 39 53.81276	0.001 m	121 39 53.87271	0.001 m
EL HGT:	17.098 m	0.002 m	16.590 m	0.002 m
ORTHO HGT:	45.334 m	0.022 m	(H = h - N WHERE N = GEOID12A HGT)	

	UTM COORDINATES	STATE PLANE COORDINATES
	UTM (Zone 10)	SPC (0402 CA 2)
NORTHING (Y)	4365638.688 m	696087.317 m
EASTING (X)	614899.215 m	2028844.773 m
CONVERGENCE	0.84807839 deg	0.21123968 deg
POINT SCALE	0.99976254	0.99993307
COMBINED FACTOR	0.99975986	0.99993039

US NATIONAL GRID DESIGNATOR: 10SFJ1489965638 (NAD 83)

+++++

MARK: cod1 (cod1 1)

REF FRAME:	NAD_83(2011) (2010.0000)		IGS08 (2014.6751)	
X:	-2619894.992 m	0.002 m	-2619895.875 m	0.002 m
Y:	-4248961.603 m	0.002 m	-4248960.295 m	0.002 m
Z:	3956927.160 m	0.002 m	3956927.132 m	0.002 m
LAT:	38 35 28.11487	0.001 m	38 35 28.12732	0.001 m
E LON:	238 20 31.77700	0.001 m	238 20 31.71758	0.001 m
W LON:	121 39 28.22300	0.001 m	121 39 28.28242	0.001 m
EL HGT:	-24.460 m	0.002 m	-24.986 m	0.002 m
ORTHO HGT:	6.463 m	0.022 m	(H = h - N WHERE N = GEOID12A HGT)	

	UTM COORDINATES	STATE PLANE COORDINATES
	UTM (Zone 10)	SPC (0402 CA 2)
NORTHING (Y)	4272260.928 m	602678.489 m
EASTING (X)	616888.293 m	2029808.422 m
CONVERGENCE	0.83727898 deg	0.21572122 deg
POINT SCALE	0.99976825	0.99995153
COMBINED FACTOR	0.99977209	0.99995537

US NATIONAL GRID DESIGNATOR: 10SFH1688872260 (NAD 83)

APPENDIX B - OPUS PROJECTS NETWORK ADJUSTMENT REPORT

+++++

MARK: s300 (s300 a 3)

REF FRAME:	NAD 83(2011) (2010.0000)		IGS08 (2014.6726)
X:	-2645886.543 m	0.001 m	-2645887.420 m 0.001 m
Y:	-4307856.961 m	0.002 m	-4307855.641 m 0.002 m
Z:	3876512.196 m	0.002 m	3876512.164 m 0.002 m
LAT:	37 39 59.41374	0.001 m	37 39 59.42610 0.001 m
E LON:	238 26 30.28629	0.001 m	238 26 30.22763 0.001 m
W LON:	121 33 29.71371	0.001 m	121 33 29.77237 0.001 m
EL HGT:	496.304 m	0.002 m	495.757 m 0.002 m
ORTHO HGT:	528.063 m	0.022 m	(H = h - N WHERE N = GEOID12A HGT)

	UTM COORDINATES	STATE PLANE COORDINATES
	UTM (Zone 10)	SPC (0403 CA 3)
NORTHING (Y)	4169791.690 m	629987.304 m
EASTING (X)	627155.978 m	1906640.117 m
CONVERGENCE	0.88111774 deg	-0.64789689 deg
POINT SCALE	0.99979915	0.99993026
COMBINED FACTOR	0.99972129	0.99985239

US NATIONAL GRID DESIGNATOR: 10SFG2715569791 (NAD 83)

+++++

MARK: sm08 (sm08 1)

REF FRAME:	NAD 83(2011) (2010.0000)		IGS08 (2014.6747)
X:	-2618019.472 m	0.001 m	-2618020.355 m 0.001 m
Y:	-4247940.539 m	0.002 m	-4247939.231 m 0.002 m
Z:	3959248.615 m	0.002 m	3959248.587 m 0.002 m
LAT:	38 37 04.45037	0.001 m	38 37 04.46284 0.001 m
E LON:	238 21 15.61592	0.001 m	238 21 15.55649 0.001 m
W LON:	121 38 44.38408	0.001 m	121 38 44.44351 0.001 m
EL HGT:	-24.366 m	0.002 m	-24.892 m 0.002 m
ORTHO HGT:	6.462 m	0.022 m	(H = h - N WHERE N = GEOID12A HGT)

	UTM COORDINATES	STATE PLANE COORDINATES
	UTM (Zone 10)	SPC (0402 CA 2)
NORTHING (Y)	4275246.053 m	605652.939 m
EASTING (X)	617905.065 m	2030857.717 m
CONVERGENCE	0.84537168 deg	0.22339874 deg
POINT SCALE	0.99977119	0.99994765
COMBINED FACTOR	0.99977501	0.99995147

US NATIONAL GRID DESIGNATOR: 10SFH1790575246 (NAD 83)

APPENDIX B - OPUS PROJECTS NETWORK ADJUSTMENT REPORT

+++++

MARK: p271 (p271 a 3)

REF FRAME:	NAD_83(2011) (2010.0000)		IGS08 (2014.6747)	
X:	-2621689.337 m	0.001 m	-2621690.215 m	0.001 m
Y:	-4242469.113 m	0.002 m	-4242467.793 m	0.002 m
Z:	3962672.872 m	0.002 m	3962672.829 m	0.002 m
LAT:	38 39 26.44791	0.001 m	38 39 26.46021	0.001 m
E LON:	238 17 07.67390	0.001 m	238 17 07.61429	0.001 m
W LON:	121 42 52.32610	0.001 m	121 42 52.38571	0.001 m
EL HGT:	-17.798 m	0.002 m	-18.342 m	0.002 m
ORTHO HGT:	12.977 m	0.022 m	(H = h - N WHERE N = GEOID12A HGT)	

	UTM COORDINATES	STATE PLANE COORDINATES
	UTM (Zone 10)	SPC (0402 CA 2)
NORTHING (Y)	4279536.917 m	610010.159 m
EASTING (X)	611847.624 m	2024846.158 m
CONVERGENCE	0.80306366 deg	0.17997663 deg
POINT SCALE	0.99975405	0.99994232
COMBINED FACTOR	0.99975684	0.99994511

US NATIONAL GRID DESIGNATOR: 10SFH1184779536 (NAD 83)

+++++

MARK: s16a (s16a 1)

REF FRAME:	NAD_83(2011) (2010.0000)		IGS08 (2014.6744)	
X:	-2615800.438 m	0.002 m	-2615801.321 m	0.002 m
Y:	-4244530.207 m	0.002 m	-4244528.900 m	0.002 m
Z:	3964338.733 m	0.002 m	3964338.706 m	0.002 m
LAT:	38 40 35.75313	0.001 m	38 40 35.76560	0.001 m
E LON:	238 21 19.74482	0.001 m	238 21 19.68534	0.001 m
W LON:	121 38 40.25518	0.001 m	121 38 40.31466	0.001 m
EL HGT:	-22.202 m	0.002 m	-22.726 m	0.002 m
ORTHO HGT:	8.450 m	0.022 m	(H = h - N WHERE N = GEOID12A HGT)	

	UTM COORDINATES	STATE PLANE COORDINATES
	UTM (Zone 10)	SPC (0402 CA 2)
NORTHING (Y)	4281761.009 m	612168.595 m
EASTING (X)	617908.663 m	2030932.110 m
CONVERGENCE	0.84717221 deg	0.22412183 deg
POINT SCALE	0.99977120	0.99993988
COMBINED FACTOR	0.99977468	0.99994336

US NATIONAL GRID DESIGNATOR: 10SFH1790881761 (NAD 83)

APPENDIX B - OPUS PROJECTS NETWORK ADJUSTMENT REPORT

+++++
 CONSTRAINED MARKS
 +++++

MARK: lnc2 (lnc2 a 2)
 CONSTRAIN: 3-D NORMAL
 ADJUST X: -0.007m (0.001m) Y: -0.008m (0.002m) Z: 0.008m (0.002m)
 ADJUST N: -0.000m (0.001m) E: -0.002m (0.001m) H: 0.013m (0.001m)

REF FRAME: NAD_83(2011) (2010.0000) IGS08 (2014.6744)
 X: -2587855.575 m 0.001 m -2587856.456 m 0.001 m
 Y: -4247830.084 m 0.002 m -4247828.780 m 0.002 m
 Z: 3979063.991 m 0.002 m 3979063.961 m 0.002 m
 LAT: 38 50 47.41586 0.001 m 38 50 47.42845 0.001 m
 E LON: 238 38 58.07306 0.001 m 238 38 58.01373 0.001 m
 W LON: 121 21 01.92694 0.001 m 121 21 01.98627 0.001 m
 EL HGT: 6.394 m 0.001 m 5.865 m 0.001 m
 ORTHO HGT: 36.400 m 0.022 m (H = h - N WHERE N = GEOID12A HGT)

	UTM COORDINATES	STATE PLANE COORDINATES
	UTM (Zone 10)	SPC (0402 CA 2)
NORTHING (Y)	4301035.814 m	631169.703 m
EASTING (X)	643142.392 m	2056377.344 m
CONVERGENCE	1.03477945 deg	0.40946695 deg
POINT SCALE	0.99985231	0.99992327
COMBINED FACTOR	0.99985131	0.99992227

US NATIONAL GRID DESIGNATOR: 10SFJ4314201035 (NAD 83)

+++++

MARK: p267 (p267 a 1)
 CONSTRAIN: 3-D NORMAL
 ADJUST X: 0.015m (0.001m) Y: 0.010m (0.002m) Z: -0.003m (0.002m)
 ADJUST N: 0.008m (0.001m) E: 0.007m (0.001m) H: -0.015m (0.001m)

REF FRAME: NAD_83(2011) (2010.0000) IGS08 (2014.6741)
 X: -2639830.530 m 0.001 m -2639831.415 m 0.001 m
 Y: -4253760.634 m 0.002 m -4253759.322 m 0.002 m
 Z: 3938614.254 m 0.002 m 3938614.228 m 0.002 m
 LAT: 38 22 49.19452 0.001 m 38 22 49.20691 0.001 m
 E LON: 238 10 36.40911 0.001 m 238 10 36.34962 0.001 m
 W LON: 121 49 23.59089 0.001 m 121 49 23.65038 0.001 m
 EL HGT: -16.983 m 0.001 m -17.508 m 0.001 m
 ORTHO HGT: 14.863 m 0.022 m (H = h - N WHERE N = GEOID12A HGT)

	UTM COORDINATES	STATE PLANE COORDINATES
	UTM (Zone 10)	SPC (0402 CA 2)
NORTHING (Y)	4248670.398 m	579236.868 m
EASTING (X)	602783.963 m	2015446.347 m
CONVERGENCE	0.73070178 deg	0.11145439 deg
POINT SCALE	0.99973010	0.99998968
COMBINED FACTOR	0.99973276	0.99999234

US NATIONAL GRID DESIGNATOR: 10SFH0278348670 (NAD 83)

APPENDIX B - OPUS PROJECTS NETWORK ADJUSTMENT REPORT

+++++

MARK: sm10 (sm10 1)

REF FRAME:	NAD_83(2011) (2010.0000)	IGS08 (2014.6754)
X:	-2618513.325 m 0.001 m	-2618514.209 m 0.001 m
Y:	-4245316.972 m 0.002 m	-4245315.665 m 0.002 m
Z:	3961723.467 m 0.002 m	3961723.439 m 0.002 m
LAT:	38 38 47.11448 0.001 m	38 38 47.12692 0.001 m
E LON:	238 20 01.30834 0.001 m	238 20 01.24887 0.001 m
W LON:	121 39 58.69166 0.001 m	121 39 58.75113 0.001 m
EL HGT:	-21.329 m 0.002 m	-21.853 m 0.002 m
ORTHO HGT:	9.429 m 0.022 m	(H = h - N WHERE N = GEOID12A HGT)

	UTM COORDINATES	STATE PLANE COORDINATES
	UTM (Zone 10)	SPC (0402 CA 2)
NORTHING (Y)	4278384.382 m	608811.659 m
EASTING (X)	616062.043 m	2029048.568 m
CONVERGENCE	0.83300330 deg	0.21038524 deg
POINT SCALE	0.99976588	0.99994375
COMBINED FACTOR	0.99976923	0.99994710

US NATIONAL GRID DESIGNATOR: 10SFH1606278384 (NAD 83)

+++++

MARK: ucd1 (ucd1 1)

REF FRAME:	NAD_83(2011) (2010.0000)	IGS08 (2014.6744)
X:	-2628825.708 m 0.001 m	-2628826.591 m 0.001 m
Y:	-4247933.423 m 0.002 m	-4247932.114 m 0.002 m
Z:	3952176.600 m 0.002 m	3952176.573 m 0.002 m
LAT:	38 32 10.44989 0.001 m	38 32 10.46230 0.001 m
E LON:	238 14 55.62017 0.001 m	238 14 55.56071 0.001 m
W LON:	121 45 04.37983 0.001 m	121 45 04.43929 0.001 m
EL HGT:	0.014 m 0.001 m	-0.510 m 0.001 m
ORTHO HGT:	31.276 m 0.022 m	(H = h - N WHERE N = GEOID12A HGT)

	UTM COORDINATES	STATE PLANE COORDINATES
	UTM (Zone 10)	SPC (0402 CA 2)
NORTHING (Y)	4266053.262 m	596557.268 m
EASTING (X)	608838.628 m	2021690.295 m
CONVERGENCE	0.77808018 deg	0.15685004 deg
POINT SCALE	0.99974588	0.99996018
COMBINED FACTOR	0.99974588	0.99996018

US NATIONAL GRID DESIGNATOR: 10SFH0883866053 (NAD 83)

APPENDIX C - MINIMALLY-CONSTRAINED GPS ADJUSTMENT REPORT

Project Information	Coordinate System
Name: C:\Projects\1037-001 \1037-001-201409.vce	Name: US State Plane 1983
Size: 902 KB	Datum: NAD 1983 (Conus)
Modified: 9/7/2014 5:44:03 PM (UTC:-7)	Zone: California Zone 2 0402
Time zone: Pacific Standard Time	Geoid: GEOID12A
Reference number:	Vertical datum:
Description:	

Network Adjustment Report

Adjustment Settings

Set-Up Errors

GNSS

Error in Height of Antenna: 0.000 m

Centering Error: 0.000 m

Covariance Display

Horizontal:

Propagated Linear Error [E]: U.S.

Constant Term [C]: 0.000 m

Scale on Linear Error [S]: 1.960

Three-Dimensional

Propagated Linear Error [E]: U.S.

Constant Term [C]: 0.000 m

Scale on Linear Error [S]: 1.960

Adjustment Statistics

Number of Iterations for Successful Adjustment: 2

Network Reference Factor: 1.00

Chi Square Test (95%): Passed

APPENDIX B - OPUS PROJECTS NETWORK ADJUSTMENT REPORT

+++++

MARK: p268 (p268 a 1)
 CONSTRAIN: 3-D NORMAL
 ADJUST X: -0.004m (0.001m) Y: 0.015m (0.002m) Z: -0.007m (0.002m)
 ADJUST N: 0.001m (0.001m) E: -0.011m (0.001m) H: -0.013m (0.001m)

REF FRAME: NAD_83(2011) (2010.0000) IGS08 (2014.6742)
 X: -2623314.307 m 0.001 m -2623315.190 m 0.001 m
 Y: -4256409.676 m 0.002 m -4256408.366 m 0.002 m
 Z: 3946714.191 m 0.002 m 3946714.163 m 0.002 m
 LAT: 38 28 24.68109 0.001 m 38 28 24.69352 0.001 m
 E LON: 238 21 12.97215 0.001 m 238 21 12.91279 0.001 m
 W LON: 121 38 47.02785 0.001 m 121 38 47.08721 0.001 m
 EL HGT: -23.431 m 0.001 m -23.958 m 0.001 m
 ORTHO HGT: 7.865 m 0.022 m (H = h - N WHERE N = GEOID12A HGT)

	UTM COORDINATES	STATE PLANE COORDINATES
	UTM (Zone 10)	SPC (0402 CA 2)
NORTHING (Y)	4259223.306 m	589626.265 m
EASTING (X)	618077.039 m	2030856.122 m
CONVERGENCE	0.84224552 deg	0.22293573 deg
POINT SCALE	0.99977170	0.99997117
COMBINED FACTOR	0.99977538	0.99997485

US NATIONAL GRID DESIGNATOR: 10SFH1807759223 (NAD 83)

+++++

MARK: sacr (sacr a 1)
 CONSTRAIN: 3-D NORMAL
 ADJUST X: 0.004m (0.001m) Y: -0.018m (0.002m) Z: 0.009m (0.002m)
 ADJUST N: -0.001m (0.001m) E: 0.013m (0.001m) H: 0.016m (0.002m)

REF FRAME: NAD_83(2011) (2010.0000) IGS08 (2014.6727)
 X: -2595053.373 m 0.001 m -2595054.254 m 0.001 m
 Y: -4259028.374 m 0.002 m -4259027.067 m 0.002 m
 Z: 3962484.552 m 0.002 m 3962484.523 m 0.002 m
 LAT: 38 39 17.97126 0.001 m 38 39 17.98386 0.001 m
 E LON: 238 38 44.80724 0.001 m 238 38 44.74800 0.001 m
 W LON: 121 21 15.19276 0.001 m 121 21 15.25200 0.001 m
 EL HGT: 7.491 m 0.002 m 6.960 m 0.002 m
 ORTHO HGT: 37.958 m 0.022 m (H = h - N WHERE N = GEOID12A HGT)

	UTM COORDINATES	STATE PLANE COORDINATES
	UTM (Zone 10)	SPC (0402 CA 2)
NORTHING (Y)	4279776.701 m	609909.476 m
EASTING (X)	643204.819 m	2056208.536 m
CONVERGENCE	1.02817703 deg	0.40714371 deg
POINT SCALE	0.99985254	0.99994262
COMBINED FACTOR	0.99985136	0.99994144

US NATIONAL GRID DESIGNATOR: 10SFH4320479776 (NAD 83)

ID	(Meter)	(Meter)	(Meter)	(Meter)	(Meter)	(Meter)	
<u>I031</u>	2025278.783	0.002	612222.692	0.002	9.603	0.012	
<u>CAST</u>	2031038.789	0.002	599682.330	0.003	4.670	0.015	
<u>COD1</u>	2029806.978	0.002	602678.863	0.002	5.965	0.013	
<u>COY1</u>	2026815.610	0.002	602666.297	0.002	7.865	0.011	
<u>CR27</u>	2026470.851	0.002	605718.258	0.002	8.521	0.019	
<u>P268</u>	2030854.677	0.003	589626.646	0.002	7.335	0.011	
<u>P271</u>	2024844.715	?	610010.534	?	12.433	?	LLh
<u>RIVE</u>	2037234.834	0.004	608949.583	0.004	11.464	0.026	
<u>S16A</u>	2030930.667	0.002	612168.968	0.002	7.933	0.013	
<u>SM08</u>	2030856.272	0.002	605653.314	0.002	5.959	0.010	
<u>SM09</u>	2034075.188	0.003	605988.111	0.003	5.125	0.017	
<u>SM10</u>	2029047.124	0.002	608812.032	0.002	8.913	0.008	
<u>SM11</u>	2028520.190	0.002	611638.181	0.002	6.534	0.013	
<u>UCD1</u>	2021688.853	0.002	596557.647	0.001	30.744	0.008	

Adjusted Geodetic Coordinates

Point ID	Latitude	Longitude	Height (Meter)	Height Error (Meter)	Constraint
<u>I031</u>	N38°40'38.15923"	W121°42'34.13964"	-21.096	0.012	
<u>CAST</u>	N38°33'50.79156"	W121°38'37.86615"	-26.319	0.015	
<u>COD1</u>	N38°35'28.12719"	W121°39'28.28263"	-24.958	0.013	

Precision Confidence Level: 95%

Degrees of Freedom: 141

Post Processed Vector Statistics

Reference Factor: 1.00

Redundancy Number: 141.00

A Priori Scalar: 1.57

Control Coordinate Comparisons

Values shown are control coordinates minus adjusted coordinates.

Point ID	Δ Easting (Meter)	Δ Northing (Meter)	Δ Elevation (Meter)	Δ Height (Meter)
I031	0.003	0.007	?	-0.012
COD1	0.005	0.004	?	-0.028
COY1	0.003	0.004	?	-0.014
S16A	0.004	0.006	?	-0.007
SM08	0.006	0.004	?	-0.023
SM10	0.004	0.006	?	-0.008
UCD1	0.000	0.000	?	0.008

Control Point Constraints

Point ID	Type	East σ (Meter)	North σ (Meter)	Height σ (Meter)	Elevation σ (Meter)
P271	Global	Fixed	Fixed	Fixed	
Fixed = 0.000001(Meter)					

Adjusted Grid Coordinates

Point	Easting	Easting Error	Northing	Northing Error	Elevation	Elevation Error	Constraint
-------	---------	---------------	----------	----------------	-----------	-----------------	------------

Error Ellipse Components

Point ID	Semi-major axis (Meter)	Semi-minor axis (Meter)	Azimuth
I031	0.003	0.002	2°
CAST	0.003	0.003	25°
COD1	0.003	0.003	46°
COY1	0.003	0.002	54°
CR27	0.003	0.003	50°
P268	0.004	0.002	85°
RIVE	0.006	0.004	50°
S16A	0.003	0.003	9°
SM08	0.003	0.002	49°
SM09	0.004	0.003	40°
SM10	0.002	0.002	29°
SM11	0.003	0.002	180°
UCD1	0.002	0.002	84°

Adjusted GPS Observations

Observation ID	Observation	A-posteriori Error	Residual	Standardized Residual	
P271 --> SM10 (PV45)	Az.	106°05'53"	0.078 sec	-0.053 sec	-0.374
	Δ Ht.	-3.503 m	0.008 m	-0.036 m	-4.824
	Ellip Dist.	4370.220 m	0.002 m	0.002 m	1.044
SM10 --> SM08 (PV22)	Az.	150°24'31"	0.099 sec	0.127 sec	1.269
	Δ Ht.	-3.024 m	0.009 m	-0.034 m	-4.145
	Ellip Dist.	3640.323 m	0.002 m	0.001 m	0.248
SM08 --> COY1 (PV11)	Az.	233°45'00"	0.068 sec	-0.037 sec	-0.480
	Δ Ht.	1.761 m	0.011 m	-0.032 m	-2.774
	Ellip Dist.	5025.113 m	0.002 m	0.003 m	1.025
SM10 --> SM08 (PV74)	Az.	150°24'31"	0.099 sec	-0.109 sec	-0.907
	Δ Ht.	-3.024 m	0.009 m	0.015 m	2.002

COY1	N38°35'28.06656"	W121°41'31.89604"	-23.108	0.011	
CR27	N38°37'07.08407"	W121°41'45.72062"	-22.363	0.019	
P268	N38°28'24.69364"	W121°38'47.08739"	-23.961	0.011	
P271	N38°39'26.46021"	W121°42'52.38571"	-18.342	?	LLh
RIVE	N38°38'50.47531"	W121°34'20.12486"	-19.269	0.026	
S16A	N38°40'35.76543"	W121°38'40.31483"	-22.719	0.013	
SM08	N38°37'04.46272"	W121°38'44.44375"	-24.869	0.010	
SM09	N38°37'14.89242"	W121°36'31.32010"	-25.676	0.017	
SM10	N38°38'47.12675"	W121°39'58.75130"	-21.845	0.008	
SM11	N38°40'18.84508"	W121°40'20.12109"	-24.146	0.013	
UCD1	N38°32'10.46230"	W121°45'04.43930"	-0.518	0.008	

Adjusted ECEF Coordinates

Point ID	X (Meter)	X Error (Meter)	Y (Meter)	Y Error (Meter)	Z (Meter)	Z Error (Meter)	3D Error (Meter)	Constraint
1031	-2620587.728	0.005	-4241522.703	0.008	3964397.346	0.008	0.013	
CAST	-2619838.599	0.007	-4251192.973	0.010	3954579.934	0.009	0.015	
COD1	-2619895.892	0.006	-4248960.313	0.009	3956927.146	0.009	0.014	
COY1	-2622443.173	0.005	-4247391.683	0.008	3956926.840	0.007	0.011	
CR27	-2621727.204	0.008	-4245595.486	0.013	3959313.317	0.012	0.019	
P268	-2623315.192	0.005	-4256408.360	0.008	3946714.164	0.007	0.012	
P271	-2621690.215	?	-4242467.792	?	3962672.829	?	?	LLh
RIVE	-2611508.416	0.011	-4249555.556	0.018	3961805.692	0.017	0.027	
S16A	-2615801.329	0.006	-4244528.905	0.009	3964338.705	0.009	0.014	
SM08	-2618020.370	0.005	-4247939.245	0.007	3959248.599	0.007	0.011	
SM09	-2615172.663	0.007	-4249456.549	0.011	3959499.368	0.011	0.017	
SM10	-2618514.217	0.004	-4245315.671	0.006	3961723.440	0.005	0.009	
SM11	-2618025.447	0.006	-4243539.221	0.008	3963930.476	0.008	0.013	
UCD1	-2628826.589	0.004	-4247932.109	0.005	3952176.568	0.005	0.008	

AQUA-266C

	ΔHt.	-3.024 m	0.009 m	-0.014 m	-1.617
	Ellip Dist.	3640.323 m	0.002 m	-0.002 m	-1.329
<u>COY1 --> CR27 (PV59)</u>	Az.	353°44'57"	0.164 sec	0.004 sec	0.029
	ΔHt.	0.744 m	0.018 m	0.012 m	0.620
	Ellip Dist.	3071.527 m	0.002 m	0.003 m	1.598
<u>P271 --> 1031 (PV55)</u>	Az.	11°16'53"	0.158 sec	-0.053 sec	-0.584
	ΔHt.	-2.754 m	0.012 m	0.016 m	1.588
	Ellip Dist.	2254.475 m	0.002 m	-0.001 m	-0.381
<u>UCD1 --> P268 (PV123)</u>	Az.	127°15'11"	0.033 sec	-0.004 sec	-0.207
	ΔHt.	-23.443 m	0.009 m	0.008 m	1.587
	Ellip Dist.	11491.744 m	0.002 m	0.000 m	0.300
<u>S16A --> RIVE (PV61)</u>	Az.	117°16'36"	0.122 sec	0.156 sec	1.374
	ΔHt.	3.451 m	0.025 m	-0.025 m	-1.137
	Ellip Dist.	7079.040 m	0.003 m	-0.006 m	-1.578
<u>P271 --> SM11 (PV44)</u>	Az.	66°17'40"	0.111 sec	-0.016 sec	-0.112
	ΔHt.	-5.804 m	0.013 m	0.031 m	1.566
	Ellip Dist.	4019.980 m	0.002 m	-0.002 m	-0.650
<u>UCD1 --> CAST (PV41)</u>	Az.	71°40'41"	0.050 sec	-0.016 sec	-0.298
	ΔHt.	-25.801 m	0.015 m	0.004 m	0.209
	Ellip Dist.	9858.657 m	0.002 m	0.005 m	1.543
<u>SM08 --> CAST (PV13)</u>	Az.	178°28'21"	0.075 sec	-0.006 sec	-0.057
	ΔHt.	-1.450 m	0.014 m	-0.026 m	-1.526
	Ellip Dist.	5974.062 m	0.002 m	0.003 m	0.939
<u>COY1 --> CR27 (PV4)</u>	Az.	353°44'57"	0.164 sec	-0.143 sec	-0.655
	ΔHt.	0.744 m	0.018 m	-0.029 m	-1.482
	Ellip Dist.	3071.527 m	0.002 m	0.001 m	0.443
<u>SM08 --> CR27 (PV10)</u>	Az.	271°04'18"	0.110 sec	-0.249 sec	-1.445
	ΔHt.	2.506 m	0.018 m	-0.007 m	-0.153
	Ellip Dist.	4386.131 m	0.002 m	0.001 m	0.225
<u>UCD1 --> COY1 (PV39)</u>	Az.	40°09'45"	0.051 sec	0.008 sec	0.151
	ΔHt.	-22.590 m	0.012 m	-0.002 m	-0.147
	Ellip Dist.	7975.266 m	0.002 m	0.005 m	1.418

	Ellip Dist.	3640.323 m	0.002 m	0.003 m	2.619
<u>P271 --> SM10 (PV46)</u>	Az.	106°05'53"	0.078 sec	-0.039 sec	-0.401
	ΔHt.	-3.503 m	0.008 m	-0.022 m	-2.389
	Ellip Dist.	4370.220 m	0.002 m	0.000 m	0.025
<u>P271 --> SM10 (PV87)</u>	Az.	106°05'53"	0.078 sec	0.052 sec	0.774
	ΔHt.	-3.503 m	0.008 m	0.018 m	2.326
	Ellip Dist.	4370.220 m	0.002 m	0.001 m	0.429
<u>SM10 --> S16A (PV19)</u>	Az.	29°30'24"	0.104 sec	-0.019 sec	-0.200
	ΔHt.	-0.874 m	0.012 m	-0.022 m	-2.170
	Ellip Dist.	3849.477 m	0.002 m	0.001 m	0.548
<u>UCD1 --> CAST (PV107)</u>	Az.	71°40'41"	0.050 sec	-0.075 sec	-0.914
	ΔHt.	-25.801 m	0.015 m	0.033 m	1.287
	Ellip Dist.	9858.657 m	0.002 m	-0.006 m	-2.101
<u>COY1 --> CAST (PV3)</u>	Az.	125°26'17"	0.096 sec	-0.018 sec	-0.152
	ΔHt.	-3.211 m	0.014 m	-0.022 m	-1.334
	Ellip Dist.	5171.245 m	0.002 m	0.006 m	2.021
<u>UCD1 --> P271 (PV97)</u>	Az.	13°21'33"	0.029 sec	-0.007 sec	-0.349
	ΔHt.	-17.824 m	0.008 m	-0.009 m	-1.988
	Ellip Dist.	13818.769 m	0.001 m	0.000 m	-0.446
<u>S16A --> 1031 (PV62)</u>	Az.	270°46'07"	0.098 sec	-0.004 sec	-0.032
	ΔHt.	1.624 m	0.015 m	-0.033 m	-1.938
	Ellip Dist.	5652.479 m	0.002 m	-0.002 m	-0.696
<u>P271 --> COY1 (PV93)</u>	Az.	165°09'29"	0.059 sec	0.032 sec	0.378
	ΔHt.	-4.766 m	0.011 m	0.028 m	1.795
	Ellip Dist.	7604.498 m	0.002 m	0.000 m	-0.158
<u>UCD1 --> COY1 (PV105)</u>	Az.	40°09'45"	0.051 sec	-0.013 sec	-0.201
	ΔHt.	-22.590 m	0.012 m	0.027 m	1.735
	Ellip Dist.	7975.266 m	0.002 m	0.001 m	0.335
<u>P268 --> CAST (PV120)</u>	Az.	1°16'19"	0.057 sec	0.003 sec	0.054
	ΔHt.	-2.358 m	0.016 m	0.045 m	1.701
	Ellip Dist.	10057.739 m	0.003 m	-0.003 m	-0.666
<u>SM10 --> SM08 (PV18)</u>	Az.	150°24'31"	0.099 sec	-0.085 sec	-0.981

AQUA-266C

	Ellip Dist.	2468.373 m	0.002 m	0.000 m	0.174
COY1 --> COD1 (PV57)	Az.	89°57'13"	0.136 sec	-0.029 sec	-0.253
	ΔHt.	-1.851 m	0.011 m	-0.009 m	-0.962
	Ellip Dist.	2991.539 m	0.002 m	0.001 m	0.394
SM08 --> SM09 (PV15)	Az.	84°17'08"	0.189 sec	0.019 sec	0.142
	ΔHt.	-0.807 m	0.014 m	0.022 m	0.961
	Ellip Dist.	3236.451 m	0.003 m	0.000 m	0.156
1031 --> SM11 (PV85)	Az.	100°24'19"	0.152 sec	0.045 sec	0.286
	ΔHt.	-3.051 m	0.014 m	-0.011 m	-0.920
	Ellip Dist.	3293.883 m	0.002 m	0.000 m	0.104
SM08 --> COD1 (PV12)	Az.	199°39'17"	0.117 sec	0.077 sec	0.919
	ΔHt.	-0.089 m	0.012 m	0.002 m	0.224
	Ellip Dist.	3154.264 m	0.002 m	0.001 m	0.775
COD1 --> CAST (PV1)	Az.	157°52'09"	0.142 sec	-0.073 sec	-0.541
	ΔHt.	-1.361 m	0.014 m	0.008 m	0.454
	Ellip Dist.	3239.991 m	0.002 m	0.002 m	0.901
SM10 --> SM11 (PV27)	Az.	349°38'56"	0.129 sec	0.026 sec	0.216
	ΔHt.	-2.301 m	0.012 m	0.014 m	0.889
	Ellip Dist.	2875.019 m	0.002 m	-0.002 m	-0.731
SM08 --> CR27 (PV65)	Az.	271°04'18"	0.110 sec	0.001 sec	0.006
	ΔHt.	2.506 m	0.018 m	-0.017 m	-0.872
	Ellip Dist.	4386.131 m	0.002 m	-0.002 m	-0.873
SM08 --> CAST (PV68)	Az.	178°28'21"	0.075 sec	0.018 sec	0.212
	ΔHt.	-1.450 m	0.014 m	0.002 m	0.075
	Ellip Dist.	5974.062 m	0.002 m	-0.003 m	-0.834
1031 --> SM11 (PV30)	Az.	100°24'19"	0.152 sec	-0.014 sec	-0.092
	ΔHt.	-3.051 m	0.014 m	0.014 m	0.826
	Ellip Dist.	3293.883 m	0.002 m	0.000 m	-0.263
S16A --> RIVE (PV6)	Az.	117°16'36"	0.122 sec	-0.019 sec	-0.158
	ΔHt.	3.451 m	0.025 m	0.023 m	0.787
	Ellip Dist.	7079.040 m	0.003 m	-0.002 m	-0.817
S16A --> 1031 (PV7)	Az.	270°46'07"	0.098 sec	-0.008 sec	-0.061

SM09 --> RIVE (PV17)	Az.	47°06'04"	0.132 sec	0.046 sec	0.457
	ΔHt.	6.408 m	0.024 m	-0.007 m	-0.274
	Ellip Dist.	4330.789 m	0.004 m	0.004 m	1.389
COD1 --> CAST (PV56)	Az.	157°52'09"	0.142 sec	0.002 sec	0.018
	ΔHt.	-1.361 m	0.014 m	-0.017 m	-1.304
	Ellip Dist.	3239.991 m	0.002 m	-0.001 m	-0.553
COY1 --> COD1 (PV2)	Az.	89°57'13"	0.136 sec	-0.045 sec	-0.383
	ΔHt.	-1.851 m	0.011 m	0.013 m	1.281
	Ellip Dist.	2991.539 m	0.002 m	0.001 m	0.775
SM08 --> COD1 (PV67)	Az.	199°39'17"	0.117 sec	-0.079 sec	-0.702
	ΔHt.	-0.089 m	0.012 m	-0.011 m	-1.172
	Ellip Dist.	3154.264 m	0.002 m	-0.001 m	-0.642
SM10 --> SM11 (PV82)	Az.	349°38'56"	0.129 sec	0.036 sec	0.260
	ΔHt.	-2.301 m	0.012 m	-0.014 m	-1.135
	Ellip Dist.	2875.019 m	0.002 m	0.000 m	-0.059
S16A --> SM09 (PV16)	Az.	153°15'34"	0.098 sec	0.001 sec	0.010
	ΔHt.	-2.957 m	0.018 m	-0.024 m	-1.129
	Ellip Dist.	6935.160 m	0.003 m	-0.001 m	-0.472
UCD1 --> P268 (PV109)	Az.	127°15'11"	0.033 sec	0.002 sec	0.091
	ΔHt.	-23.443 m	0.009 m	-0.005 m	-1.077
	Ellip Dist.	11491.744 m	0.002 m	0.000 m	0.244
SM10 --> S16A (PV75)	Az.	29°30'24"	0.104 sec	-0.012 sec	-0.115
	ΔHt.	-0.874 m	0.012 m	0.002 m	0.171
	Ellip Dist.	3849.477 m	0.002 m	0.003 m	1.030
SM10 --> CR27 (PV77)	Az.	219°59'43"	0.117 sec	-0.013 sec	-0.119
	ΔHt.	-0.518 m	0.019 m	0.022 m	0.977
	Ellip Dist.	4026.212 m	0.003 m	-0.001 m	-0.399
COY1 --> CAST (PV58)	Az.	125°26'17"	0.096 sec	0.010 sec	0.080
	ΔHt.	-3.211 m	0.014 m	0.011 m	0.474
	Ellip Dist.	5171.245 m	0.002 m	-0.003 m	-0.970
S16A --> SM11 (PV84)	Az.	257°48'20"	0.191 sec	0.025 sec	0.146
	ΔHt.	-1.427 m	0.013 m	-0.011 m	-0.963

P271 --> COY1 (PV52)	Az.	165°09'29"	0.059 sec	-0.031 sec	-0.376
	ΔHt.	-4.766 m	0.011 m	0.001 m	0.099
	Ellip Dist.	7604.498 m	0.002 m	0.000 m	0.028
P271 --> CR27 (PV92)	Az.	159°25'51"	0.110 sec	0.016 sec	0.175
	ΔHt.	-4.021 m	0.019 m	0.002 m	0.131
	Ellip Dist.	4590.237 m	0.002 m	0.001 m	0.260
SM10 --> SM09 (PV73)	Az.	119°31'50"	0.120 sec	0.007 sec	0.034
	ΔHt.	-3.831 m	0.016 m	0.002 m	0.043
	Ellip Dist.	5767.112 m	0.003 m	0.001 m	0.095

Covariance Terms

From Point	To Point	Components	A-posteriori Error	Horiz. Precision (Ratio)	3D Precision (Ratio)	
1031	P271	Az.	191°17'05"	0.157 sec	1 : 1057493	1 : 1057519
		ΔHt.	2.754 m	0.012 m		
		ΔElev.	2.830 m	0.012 m		
		Ellip Dist.	2254.475 m	0.002 m		
1031	S16A	Az.	90°43'41"	0.098 sec	1 : 2552733	1 : 2552187
		ΔHt.	-1.624 m	0.015 m		
		ΔElev.	-1.670 m	0.015 m		
		Ellip Dist.	5652.479 m	0.002 m		
1031	SM11	Az.	100°24'19"	0.153 sec	1 : 1653677	1 : 1651496
		ΔHt.	-3.051 m	0.014 m		
		ΔElev.	-3.069 m	0.014 m		
		Ellip Dist.	3293.883 m	0.002 m		
CAST	COD1	Az.	337°52'41"	0.142 sec	1 : 1340853	1 : 1339734
		ΔHt.	1.361 m	0.014 m		
		ΔElev.	1.294 m	0.014 m		
		Ellip Dist.	3239.991 m	0.002 m		
CAST	COY1	Az.	305°28'06"	0.096 sec	1 : 2395191	1 : 2392920
		ΔHt.	3.211 m	0.014 m		

	ΔHt.	1.624 m	0.015 m	-0.003 m	-0.119
	Ellip Dist.	5652.479 m	0.002 m	-0.002 m	-0.694
SM08 --> SM09 (PV70)	Az.	84°17'08"	0.189 sec	0.077 sec	0.364
	ΔHt.	-0.807 m	0.014 m	-0.001 m	-0.228
	Ellip Dist.	3236.451 m	0.003 m	0.002 m	0.693
P271 --> CR27 (PV51)	Az.	159°25'51"	0.110 sec	-0.014 sec	-0.067
	ΔHt.	-4.021 m	0.019 m	0.031 m	0.690
	Ellip Dist.	4590.237 m	0.002 m	0.001 m	0.213
P271 --> SM11 (PV86)	Az.	66°17'40"	0.111 sec	0.032 sec	0.211
	ΔHt.	-5.804 m	0.013 m	0.002 m	0.171
	Ellip Dist.	4019.980 m	0.002 m	-0.002 m	-0.657
UCD1 --> P271 (PV43)	Az.	13°21'33"	0.029 sec	0.004 sec	0.211
	ΔHt.	-17.824 m	0.008 m	0.003 m	0.608
	Ellip Dist.	13818.769 m	0.001 m	0.000 m	-0.437
SM08 --> COY1 (PV66)	Az.	233°45'00"	0.068 sec	-0.037 sec	-0.435
	ΔHt.	1.761 m	0.011 m	-0.006 m	-0.410
	Ellip Dist.	5025.113 m	0.002 m	-0.002 m	-0.583
SM09 --> RIVE (PV72)	Az.	47°06'04"	0.132 sec	0.047 sec	0.561
	ΔHt.	6.408 m	0.024 m	-0.005 m	-0.373
	Ellip Dist.	4330.789 m	0.004 m	-0.002 m	-0.560
S16A --> SM11 (PV29)	Az.	257°48'20"	0.191 sec	-0.032 sec	-0.195
	ΔHt.	-1.427 m	0.013 m	0.007 m	0.493
	Ellip Dist.	2468.373 m	0.002 m	-0.001 m	-0.382
P268 --> CAST (PV134)	Az.	1°16'19"	0.057 sec	0.030 sec	0.472
	ΔHt.	-2.358 m	0.016 m	-0.004 m	-0.218
	Ellip Dist.	10057.739 m	0.003 m	-0.001 m	-0.245
P271 --> 1031 (PV96)	Az.	11°16'53"	0.158 sec	-0.024 sec	-0.182
	ΔHt.	-2.754 m	0.012 m	-0.003 m	-0.349
	Ellip Dist.	2254.475 m	0.002 m	-0.001 m	-0.446
S16A --> SM09 (PV71)	Az.	153°15'34"	0.098 sec	0.091 sec	0.391
	ΔHt.	-2.957 m	0.018 m	-0.006 m	-0.122
	Ellip Dist.	6935.160 m	0.003 m	0.001 m	0.189

COY1	UCD1	Az.	220°11'58"	0.051 sec	1 : 3412861	1 : 3411619
		ΔHt.	22.590 m	0.012 m		
		ΔElev.	22.879 m	0.012 m		
		Ellip Dist.	7975.266 m	0.002 m		
CR27	P271	Az.	339°26'32"	0.110 sec	1 : 2014188	1 : 2015173
		ΔHt.	4.021 m	0.019 m		
		ΔElev.	3.912 m	0.019 m		
		Ellip Dist.	4590.237 m	0.002 m		
CR27	SM08	Az.	91°02'25"	0.110 sec	1 : 1837654	1 : 1839212
		ΔHt.	-2.506 m	0.018 m		
		ΔElev.	-2.562 m	0.018 m		
		Ellip Dist.	4386.131 m	0.002 m		
CR27	SM10	Az.	39°58'37"	0.117 sec	1 : 1578617	1 : 1578491
		ΔHt.	0.518 m	0.019 m		
		ΔElev.	0.392 m	0.019 m		
		Ellip Dist.	4026.212 m	0.003 m		
RIVE	S16A	Az.	297°19'18"	0.122 sec	1 : 2116031	1 : 2118405
		ΔHt.	-3.451 m	0.025 m		
		ΔElev.	-3.532 m	0.025 m		
		Ellip Dist.	7079.040 m	0.003 m		
RIVE	SM09	Az.	227°07'26"	0.132 sec	1 : 1055317	1 : 1054019
		ΔHt.	-6.408 m	0.024 m		
		ΔElev.	-6.339 m	0.024 m		
		Ellip Dist.	4330.789 m	0.004 m		
S16A	SM09	Az.	153°15'34"	0.098 sec	1 : 2574971	1 : 2573056
		ΔHt.	-2.957 m	0.018 m		
		ΔElev.	-2.807 m	0.018 m		
		Ellip Dist.	6935.160 m	0.003 m		
S16A	SM10	Az.	209°31'13"	0.103 sec	1 : 1726658	1 : 1727353
		ΔHt.	0.874 m	0.012 m		
		ΔElev.	0.980 m	0.012 m		
		Ellip Dist.	3849.477 m	0.002 m		
S16A	SM11	Az.	257°48'20"	0.191 sec	1 : 1312698	1 : 1313696
		ΔHt.	-1.427 m	0.013 m		

		ΔElev.	3.195 m	0.014 m		
		Ellip Dist.	5171.245 m	0.002 m		
<u>CAST</u>	<u>P268</u>	Az.	181°16'24"	0.057 sec	1 : 3773990	1 : 3772785
		ΔHt.	2.358 m	0.016 m		
		ΔElev.	2.665 m	0.016 m		
		Ellip Dist.	10057.739 m	0.003 m		
<u>CAST</u>	<u>SM08</u>	Az.	358°28'25"	0.075 sec	1 : 2408874	1 : 2408166
		ΔHt.	1.450 m	0.014 m		
		ΔElev.	1.289 m	0.014 m		
		Ellip Dist.	5974.062 m	0.002 m		
<u>CAST</u>	<u>UCD1</u>	Az.	251°44'42"	0.050 sec	1 : 4123090	1 : 4118443
		ΔHt.	25.801 m	0.015 m		
		ΔElev.	26.074 m	0.015 m		
		Ellip Dist.	9858.657 m	0.002 m		
<u>COD1</u>	<u>COY1</u>	Az.	269°58'30"	0.136 sec	1 : 1527228	1 : 1528903
		ΔHt.	1.851 m	0.011 m		
		ΔElev.	1.901 m	0.011 m		
		Ellip Dist.	2991.539 m	0.002 m		
<u>COD1</u>	<u>SM08</u>	Az.	19°38'49"	0.116 sec	1 : 1461741	1 : 1460875
		ΔHt.	0.089 m	0.012 m		
		ΔElev.	-0.006 m	0.012 m		
		Ellip Dist.	3154.264 m	0.002 m		
<u>COY1</u>	<u>CR27</u>	Az.	353°44'57"	0.163 sec	1 : 1317734	1 : 1317312
		ΔHt.	0.744 m	0.018 m		
		ΔElev.	0.656 m	0.018 m		
		Ellip Dist.	3071.527 m	0.002 m		
<u>COY1</u>	<u>P271</u>	Az.	345°10'19"	0.059 sec	1 : 4083332	1 : 4081238
		ΔHt.	4.766 m	0.011 m		
		ΔElev.	4.568 m	0.011 m		
		Ellip Dist.	7604.498 m	0.002 m		
<u>COY1</u>	<u>SM08</u>	Az.	53°43'15"	0.068 sec	1 : 2385709	1 : 2386218
		ΔHt.	-1.761 m	0.011 m		
		ΔElev.	-1.906 m	0.011 m		
		Ellip Dist.	5025.113 m	0.002 m		

Date: 9/7/2014 5:59:04 PM	Project: C:\Projects\1037-001 \1037-001-201409.vce	Trimble Business Center
---------------------------	---	-------------------------

		ΔElev.	-1.399 m	0.013 m		
		Ellip Dist.	2468.373 m	0.002 m		
<u>SM08</u>	<u>SM09</u>	Az.	84°17'08"	0.189 sec	1 : 1086141	1 : 1087567
		ΔHt.	-0.807 m	0.014 m		
		ΔElev.	-0.834 m	0.014 m		
		Ellip Dist.	3236.451 m	0.003 m		
<u>SM08</u>	<u>SM10</u>	Az.	330°25'17"	0.099 sec	1 : 2290748	1 : 2290777
		ΔHt.	3.024 m	0.009 m		
		ΔElev.	2.954 m	0.009 m		
		Ellip Dist.	3640.323 m	0.002 m		
<u>SM09</u>	<u>SM10</u>	Az.	299°33'59"	0.120 sec	1 : 2173531	1 : 2175731
		ΔHt.	3.831 m	0.016 m		
		ΔElev.	3.787 m	0.016 m		
		Ellip Dist.	5767.112 m	0.003 m		
<u>SM10</u>	<u>P271</u>	Az.	286°07'41"	0.078 sec	1 : 2798098	1 : 2798632
		ΔHt.	3.503 m	0.008 m		
		ΔElev.	3.520 m	0.008 m		
		Ellip Dist.	4370.220 m	0.002 m		
<u>SM10</u>	<u>SM11</u>	Az.	349°38'56"	0.129 sec	1 : 1335421	1 : 1335663
		ΔHt.	-2.301 m	0.012 m		
		ΔElev.	-2.379 m	0.012 m		
		Ellip Dist.	2875.019 m	0.002 m		
<u>SM11</u>	<u>P271</u>	Az.	246°19'15"	0.111 sec	1 : 2111126	1 : 2110872
		ΔHt.	5.804 m	0.013 m		
		ΔElev.	5.899 m	0.013 m		
		Ellip Dist.	4019.980 m	0.002 m		
<u>UCD1</u>	<u>P268</u>	Az.	127°15'11"	0.033 sec	1 : 5969252	1 : 5977614
		ΔHt.	-23.443 m	0.009 m		
		ΔElev.	-23.409 m	0.009 m		
		Ellip Dist.	11491.744 m	0.002 m		
<u>UCD1</u>	<u>P271</u>	Az.	13°21'33"	0.029 sec	1 : 9593411	1 : 9578680
		ΔHt.	-17.824 m	0.008 m		
		ΔElev.	-18.311 m	0.008 m		
		Ellip Dist.	13818.769 m	0.001 m		

APPENDIX D – STAR*NET NETWORK ADJUSTMENT REPORT

Summary of Unadjusted Input Observations
=====

Number of Entered Stations (Meters) = 10
(Elevations Marked with (*) are Ellipsoid Heights)

Partially Fixed	N StdErr	E StdErr	Elev StdErr	Description
15	608777.2764 0.0100	2029032.5965 0.0100	10.8178 FREE	CONTROL
16 MARK	608797.8742	2028884.0119	10.0000	CONTROL AZ
	FREE	FREE	FIXED	

Partially Fixed	Latitude N-StdErr	Longitude E-StdErr	Elev StdErr	Description
UCD1	38-32-10.449890 0.0010	121-45-04.379830 0.0010	0.0140* 0.0010	UCD1
P268	38-28-24.681090 0.0010	121-38-47.027850 0.0010	-23.4310* 0.0010	P268
P271	38-39-26.447910 0.0010	121-42-52.326100 0.0010	-17.7980* 0.0020	P271
COD1	38-35-28.114870 0.0010	121-39-28.223000 0.0010	-24.4600* 0.0020	COD1
COY1	38-35-28.054260 0.0010	121-41-31.836460 0.0010	-22.5980* 0.0020	COY1
S16A	38-40-35.753130 0.0010	121-38-40.255180 0.0010	-22.2020* 0.0020	S16A
SM08	38-37-04.450370 0.0010	121-38-44.384080 0.0010	-24.3660* 0.0020	SM08
SM10	38-38-47.114480 0.0010	121-39-58.691660 0.0010	-21.3290* 0.0020	SM10

Number of Measured Angle Observations (DMS) = 2

From	At	To	Angle	StdErr	t-T
16	15	EX11	0-00-01.00	4.76	-0.00
16	15	SM10	107-06-31.00	12.67	-0.02

Number of Measured Distance Observations (Meters) = 3

From	To	Distance	StdErr	HI	HT	Comb Grid	Type
15	16	121.9202	FIXED	0.000	0.000	0.9999470	S
15	EX11	89.6510	0.0031	1.524	2.121	0.9999472	S
15	SM10	37.9205	0.0030	1.524	2.121	0.9999470	S

Number of Zenith Observations (DMS) = 2

From	To	Zenith	StdErr	HI	HT
15	EX11	91-45-28.00	5.35	1.524	2.121
15	SM10	91-11-33.00	11.89	1.524	2.121

APPENDIX D – STAR*NET NETWORK ADJUSTMENT REPORT

Note: In order to effectively incorporate the trigonometric leveling data, approximate positions for the instrument and backsight stations were determined in order to provide the adjustment engine with adequate seed data. This pertains to stations 15 and 16 referenced in the adjustment report. These station were ephemeral and are not marked on the ground.

Summary of Files Used and Option Settings
 =====

Project Folder and Data Files

Project Name 1037-001-201409
 Project Folder C:\STAR
 Data File List 1. 1037-001-201409.dat
 2. 1037-001-201409.gps

Project Option Settings

STAR*NET Run Mode : Adjust with Error Propagation
 Type of Adjustment : 3D
 Project Units : Meters; DMS
 Coordinate System : Lambert NAD83; CA Zone 2 0402
 Geoid Height Model : GEOID12A-5.GHT
 Longitude Sign Convention : Positive West
 Input/Output Coordinate Order : North-East
 Angle Data Station Order : From-At-To
 Distance/Vertical Data Type : Slope/Zenith
 Convergence Limit; Max Iterations : 0.010000; 99
 Default Coefficient of Refraction : 0.070000
 Create Coordinate File : Yes
 Create Geodetic Position File : Yes
 Create Ground Scale Coordinate File : No
 Create Dump File : No
 GPS Vector Standard Error Factors : 1.9600
 GPS Vector Centering (Meters) : 0.00100
 GPS Vector Transformations : None

Company Library Instrument TCRA1102

Note: Leica TCRA1102plus Robot

Distances (Constant) : 0.002012 Meters
 Distances (PPM) : 2.000000
 Angles : 2.000000 Seconds
 Directions : 2.000000 Seconds
 Azimuths & Bearings : 2.000000 Seconds
 Zeniths : 2.000000 Seconds
 Elevation Differences (Constant) : 0.001524 Meters
 Elevation Differences (PPM) : 0.000000
 Differential Levels : 0.002403 Meters / Km
 Centering Error Instrument : 0.001524 Meters
 Centering Error Target : 0.001524 Meters
 Centering Error Vertical : 0.001524 Meters

APPENDIX D – STAR*NET NETWORK ADJUSTMENT REPORT

(V14 PostProcessed 03-SEP-2014 19:22:14.0 1037-001-201409.asc)			
COY1	2547.2854	0.0060	0.8504
COD1	-1568.6208	0.0097	-0.8142
	0.2983	0.0099	-0.9366
(V15 PostProcessed 04-SEP-2014 15:27:29.0 1037-001-201409.asc)			
COY1	2547.2770	0.0065	0.8404
COD1	-1568.6355	0.0092	-0.8049
	0.3121	0.0086	-0.9157
(V16 PostProcessed 04-SEP-2014 15:14:29.0 1037-001-201409.asc)			
COY1	2604.5800	0.0133	0.9524
CAST	-3801.2848	0.0202	-0.9250
	-2346.9131	0.0184	-0.9437
(V17 PostProcessed 03-SEP-2014 19:18:44.0 1037-001-201409.asc)			
COY1	2604.5616	0.0102	0.8826
CAST	-3801.2998	0.0140	-0.8777
	-2346.8893	0.0151	-0.9073
(V18 PostProcessed 04-SEP-2014 17:13:59.0 1037-001-201409.asc)			
COY1	715.9736	0.0121	0.9492
CR27	1796.2033	0.0180	-0.9334
	2386.4675	0.0168	-0.9689
(V19 PostProcessed 03-SEP-2014 21:14:44.0 1037-001-201409.asc)			
COY1	715.9592	0.0102	0.8935
CR27	1796.1763	0.0196	-0.8967
	2386.4945	0.0164	-0.9413
(V20 PostProcessed 03-SEP-2014 15:05:29.0 1037-001-201409.asc)			
1031	2562.2871	0.0102	0.9425
SM11	-2016.5094	0.0153	-0.9188
	-466.8788	0.0140	-0.9408
(V21 PostProcessed 04-SEP-2014 19:25:29.0 1037-001-201409.asc)			
1031	2562.2768	0.0079	0.8726
SM11	-2016.5252	0.0116	-0.8632
	-466.8624	0.0121	-0.8995
(V22 PostProcessed 04-SEP-2014 14:06:29.0 1037-001-201409.asc)			
SM10	493.8504	0.0050	0.6902
SM08	-2623.5621	0.0075	-0.7181
	-2474.8491	0.0070	-0.9094
(V23 PostProcessed 03-SEP-2014 18:54:29.0 1037-001-201409.asc)			
SM10	493.8347	0.0051	0.7938
SM08	-2623.5967	0.0086	-0.7315
	-2474.8189	0.0078	-0.7422
(V24 PostProcessed 03-SEP-2014 14:11:29.0 1037-001-201409.asc)			
SM10	493.8397	0.0060	0.8761
SM08	-2623.5852	0.0085	-0.8403
	-2474.8345	0.0078	-0.8801
(V25 PostProcessed 04-SEP-2014 21:01:44.0 1037-001-201409.asc)			
SM10	3341.5544	0.0190	0.9476
SM09	-4140.8760	0.0454	-0.9398
	-2224.0729	0.0390	-0.9803
(V26 PostProcessed 03-SEP-2014 15:05:29.0 1037-001-201409.asc)			
SM10	488.7758	0.0093	0.9400
SM11	1776.4598	0.0139	-0.9163
	2207.0288	0.0128	-0.9392
(V27 PostProcessed 04-SEP-2014 19:25:29.0 1037-001-201409.asc)			
SM10	488.7640	0.0078	0.8854
SM11	1776.4406	0.0111	-0.8866
	2207.0449	0.0120	-0.9117

APPENDIX D – STAR*NET NETWORK ADJUSTMENT REPORT

Number of GPS Vector Observations (Meters) = 60

From To	DeltaX DeltaY DeltaZ	StdErrX StdErrY StdErrZ	CorrelXY CorrelXZ CorrelYZ
(V1 PostProcessed 04-SEP-2014 14:32:59.0 1037-001-201409.asc)			
P271	-752.9454	0.0096	0.8572
COY1	-4923.8725	0.0144	-0.8403
	-5746.0067	0.0129	-0.9366
(V2 PostProcessed 03-SEP-2014 19:18:44.0 1037-001-201409.asc)			
P271	-752.9585	0.0077	0.8068
COY1	-4923.8892	0.0119	-0.7546
	-5745.9901	0.0119	-0.9140
(V3 PostProcessed 03-SEP-2014 21:14:44.0 1037-001-201409.asc)			
P271	-36.9762	0.0203	0.9595
CR27	-3127.6721	0.0414	-0.9651
	-3359.5302	0.0347	-0.9799
(V4 PostProcessed 04-SEP-2014 17:13:59.0 1037-001-201409.asc)			
P271	-36.9872	0.0109	0.9386
CR27	-3127.6915	0.0178	-0.9311
	-3359.5126	0.0164	-0.9652
(V5 PostProcessed 03-SEP-2014 14:32:29.0 1037-001-201409.asc)			
P271	1102.4947	0.0069	0.9266
1031	945.1001	0.0101	-0.8967
	1724.5077	0.0090	-0.9279
(V6 PostProcessed 04-SEP-2014 19:09:29.0 1037-001-201409.asc)			
P271	1102.4868	0.0059	0.8670
1031	945.0878	0.0086	-0.8554
	1724.5196	0.0089	-0.8984
(V7 PostProcessed 04-SEP-2014 13:46:59.0 1037-001-201409.asc)			
P271	3176.0059	0.0050	0.6951
SM10	-2847.8650	0.0080	-0.7264
	-949.3992	0.0073	-0.9107
(V8 PostProcessed 03-SEP-2014 18:54:29.0 1037-001-201409.asc)			
P271	3175.9814	0.0049	0.7317
SM10	-2847.9006	0.0080	-0.6591
	-949.3669	0.0074	-0.6651
(V9 PostProcessed 03-SEP-2014 14:11:29.0 1037-001-201409.asc)			
P271	3175.9888	0.0061	0.8707
SM10	-2847.8932	0.0088	-0.8237
	-949.3755	0.0081	-0.8704
(V10 PostProcessed 03-SEP-2014 15:05:29.0 1037-001-201409.asc)			
P271	3664.7827	0.0117	0.9458
SM11	-1071.4086	0.0175	-0.9222
	1257.6282	0.0161	-0.9429
(V11 PostProcessed 04-SEP-2014 19:25:29.0 1037-001-201409.asc)			
P271	3664.7711	0.0086	0.8781
SM11	-1071.4269	0.0128	-0.8669
	1257.6467	0.0133	-0.9039
(V12 PostProcessed 03-SEP-2014 23:59:44.0 1037-001-201409.asc)			
P271	-7136.3762	0.0041	0.7048
UCD1	-5464.3203	0.0058	-0.7371
	-10496.2575	0.0052	-0.8683
(V13 PostProcessed 02-SEP-2014 23:59:44.0 1037-001-201409.asc)			
P271	-7136.3806	0.0040	0.6686
UCD1	-5464.3285	0.0054	-0.7259
	-10496.2503	0.0049	-0.8473

APPENDIX D – STAR*NET NETWORK ADJUSTMENT REPORT

(V42 PostProcessed 03-SEP-2014 19:18:44.0 1037-001-201409.asc)			
SMO8	-4422.8140	0.0069	0.8125
COY1	547.5408	0.0108	-0.7640
	-2321.7369	0.0110	-0.9201
(V43 PostProcessed 03-SEP-2014 19:22:14.0 1037-001-201409.asc)			
SMO8	-1875.5191	0.0061	0.8700
COD1	-1021.0666	0.0098	-0.8321
	-2321.4527	0.0100	-0.9349
(V44 PostProcessed 04-SEP-2014 15:27:29.0 1037-001-201409.asc)			
SMO8	-1875.5279	0.0068	0.8490
COD1	-1021.0749	0.0096	-0.8110
	-2321.4456	0.0089	-0.9174
(V45 PostProcessed 04-SEP-2014 15:14:29.0 1037-001-201409.asc)			
SMO8	-1818.2287	0.0137	0.9509
CAST	-3253.7289	0.0210	-0.9212
	-4668.6679	0.0190	-0.9414
(V46 PostProcessed 03-SEP-2014 19:18:14.0 1037-001-201409.asc)			
SMO8	-1818.2387	0.0106	0.8813
CAST	-3253.7435	0.0145	-0.8756
	-4668.6457	0.0157	-0.9062
(V47 PostProcessed 03-SEP-2014 17:11:44.0 1037-001-201409.asc)			
SMO8	2847.7158	0.0133	0.9484
SMO9	-1517.2889	0.0198	-0.9268
	250.7560	0.0184	-0.9711
(V48 PostProcessed 04-SEP-2014 21:01:44.0 1037-001-201409.asc)			
SMO8	2847.7052	0.0056	0.6116
SMO9	-1517.3030	0.0080	-0.4736
	250.7710	0.0095	-0.7819
(V49 PostProcessed 03-SEP-2014 17:05:29.0 1037-001-201409.asc)			
S16A	4292.9231	0.0180	0.9434
RIVE	-5026.6381	0.0260	-0.9171
	-2533.0286	0.0243	-0.9685
(V50 PostProcessed 04-SEP-2014 21:14:44.0 1037-001-201409.asc)			
S16A	4292.9099	0.0114	0.8342
RIVE	-5026.6715	0.0230	-0.8259
	-2532.9959	0.0210	-0.9687
(V51 PostProcessed 03-SEP-2014 15:12:29.0 1037-001-201409.asc)			
S16A	-4786.4011	0.0139	0.9489
1031	3006.2012	0.0209	-0.9268
	58.6424	0.0192	-0.9429
(V52 PostProcessed 04-SEP-2014 19:21:29.0 1037-001-201409.asc)			
S16A	-4786.4137	0.0107	0.8819
1031	3006.1814	0.0146	-0.8793
	58.6612	0.0161	-0.9070
(V53 PostProcessed 04-SEP-2014 21:01:44.0 1037-001-201409.asc)			
S16A	628.6664	0.0203	0.9486
SMO9	-4927.6479	0.0486	-0.9408
	-4839.3318	0.0417	-0.9807
(V54 PostProcessed 03-SEP-2014 17:11:44.0 1037-001-201409.asc)			
S16A	628.6564	0.0116	0.9211
SMO9	-4927.6607	0.0201	-0.8980
	-4839.3232	0.0186	-0.9624
(V55 PostProcessed 04-SEP-2014 19:21:29.0 1037-001-201409.asc)			
S16A	-2712.8863	0.0072	0.8236
SM10	-786.7665	0.0125	-0.7790
	-2615.2619	0.0129	-0.9360

APPENDIX D – STAR*NET NETWORK ADJUSTMENT REPORT

(V28 PostProcessed 04-SEP-2014 17:13:59.0 1037-001-201409.asc)			
SM10	-3212.9788	0.0139	0.9485
CR27	-279.8002	0.0206	-0.9317
	-2410.1374	0.0194	-0.9685
(V29 PostProcessed 03-SEP-2014 15:12:29.0 1037-001-201409.asc)			
SM11	2224.1149	0.0087	0.9387
S16A	-989.6889	0.0130	-0.9162
	408.2336	0.0120	-0.9374
(V30 PostProcessed 04-SEP-2014 19:25:29.0 1037-001-201409.asc)			
SM11	2224.1034	0.0072	0.8861
S16A	-989.7031	0.0102	-0.8874
	408.2518	0.0110	-0.9131
(V31 PostProcessed 02-SEP-2014 23:59:44.0 1037-001-201409.asc)			
UCD1	5511.3999	0.0042	0.6963
P268	-8476.2458	0.0059	-0.7509
	-5462.4091	0.0053	-0.8662
(V32 PostProcessed 03-SEP-2014 23:59:44.0 1037-001-201409.asc)			
UCD1	5511.3951	0.0040	0.6703
P268	-8476.2542	0.0056	-0.7107
	-5462.4011	0.0050	-0.8494
(V33 PostProcessed 04-SEP-2014 14:32:59.0 1037-001-201409.asc)			
UCD1	6383.4259	0.0097	0.8587
COY1	540.4438	0.0145	-0.8420
	4750.2535	0.0130	-0.9373
(V34 PostProcessed 03-SEP-2014 19:18:44.0 1037-001-201409.asc)			
UCD1	6383.4106	0.0078	0.8154
COY1	540.4248	0.0123	-0.7643
	4750.2699	0.0125	-0.9217
(V35 PostProcessed 04-SEP-2014 15:14:29.0 1037-001-201409.asc)			
UCD1	8988.0084	0.0149	0.9521
CAST	-3260.8461	0.0229	-0.9223
	2403.3439	0.0208	-0.9421
(V36 PostProcessed 03-SEP-2014 19:18:14.0 1037-001-201409.asc)			
UCD1	8987.9863	0.0111	0.8819
CAST	-3260.8604	0.0156	-0.8757
	2403.3619	0.0153	-0.9377
(V37 PostProcessed 03-SEP-2014 19:22:14.0 1037-001-201409.asc)			
COD1	57.2949	0.0105	0.9256
CAST	-2232.6530	0.0150	-0.9247
	-2347.2158	0.0159	-0.9419
(V38 PostProcessed 04-SEP-2014 15:27:29.0 1037-001-201409.asc)			
COD1	57.2859	0.0083	0.9145
CAST	-2232.6724	0.0126	-0.8701
	-2347.2029	0.0117	-0.8995
(V39 PostProcessed 03-SEP-2014 21:14:44.0 1037-001-201409.asc)			
SM08	-3706.8335	0.0196	0.9591
CR27	2343.7568	0.0399	-0.9646
	64.7268	0.0334	-0.9796
(V40 PostProcessed 04-SEP-2014 17:13:59.0 1037-001-201409.asc)			
SM08	-3706.8425	0.0124	0.9315
CR27	2343.7488	0.0183	-0.9157
	64.7293	0.0167	-0.9674
(V41 PostProcessed 04-SEP-2014 14:32:59.0 1037-001-201409.asc)			
SM08	-4422.8070	0.0086	0.8601
COY1	547.5590	0.0128	-0.8409
	-2321.7556	0.0114	-0.9342

APPENDIX D – STAR*NET NETWORK ADJUSTMENT REPORT

Adjustment Statistical Summary

```

=====
Iterations                =      4
Number of Stations        =     17
Number of Observations    =    213
Number of Unknowns        =     50
Number of Redundant Obs   =    163

```

Observation	Count	Sum Squares of StdRes	Error Factor
Coordinates	26	21.798	1.047
Angles	2	0.000	0.000
Distances	3	0.000	0.006
Zeniths	2	0.000	0.000
GPS Deltas	180	154.960	1.061
Total	213	176.758	1.041

The Chi-Square Test at 5.00% Level Passed
Lower/Upper Bounds (0.891/1.108)

APPENDIX D – STAR*NET NETWORK ADJUSTMENT REPORT

(V56 PostProcessed 03-SEP-2014 15:12:29.0 1037-001-201409.asc)			
S16A	-2712.8948	0.0070	0.8909
SM10	-786.7763	0.0103	-0.8603
	-2615.2551	0.0095	-0.8868
(V57 PostProcessed 04-SEP-2014 15:14:29.0 1037-001-201409.asc)			
P268	3476.6114	0.0152	0.9531
CAST	5215.4185	0.0233	-0.9239
	7865.7445	0.0211	-0.9431
(V58 PostProcessed 03-SEP-2014 19:18:14.0 1037-001-201409.asc)			
P268	3476.5897	0.0119	0.8956
CAST	5215.3857	0.0169	-0.8890
	7865.7733	0.0163	-0.9442
(V59 PostProcessed 03-SEP-2014 17:11:44.0 1037-001-201409.asc)			
RIVE	-3664.2397	0.0159	0.9502
SM09	99.0115	0.0236	-0.9285
	-2306.3269	0.0220	-0.9724
(V60 PostProcessed 04-SEP-2014 21:14:44.0 1037-001-201409.asc)			
RIVE	-3664.2659	0.0095	0.8675
SM09	98.9699	0.0164	-0.8395
	-2306.2899	0.0156	-0.9609

APPENDIX D – STAR*NET NETWORK ADJUSTMENT REPORT

Convergence Angles (DMS) and Grid Factors at Stations
 (Grid Azimuth = Geodetic Azimuth - Convergence)
 (Elevation Factor Includes a Geoid Height Correction at Each Station)

Station	Convergence	----- Factors -----		
	Angle	Scale	x Elevation	= Combined
UCD1	0-09-24.66	0.99996018	1.00000000	0.99996018
P268	0-13-22.57	0.99997117	1.00000368	0.99997484
P271	0-10-47.92	0.99994232	1.00000279	0.99994511
COD1	0-12-56.60	0.99995153	1.00000384	0.99995537
COY1	0-11-38.66	0.99995154	1.00000355	0.99995508
S16A	0-13-26.84	0.99993988	1.00000348	0.99994337
SMO8	0-13-24.24	0.99994765	1.00000382	0.99995147
SM10	0-12-37.39	0.99994375	1.00000335	0.99994709
15	0-12-36.97	0.99994379	1.00000313	0.99994692
16	0-12-33.82	0.99994377	1.00000326	0.99994702
EX11	0-12-34.65	0.99994377	1.00000365	0.99994743
CR27	0-11-29.95	0.99994755	1.00000343	0.99995097
1031	0-10-59.42	0.99993980	1.00000323	0.99994303
SM11	0-12-23.91	0.99994047	1.00000371	0.99994418
CAST	0-13-28.38	0.99995568	1.00000405	0.99995973
SMO9	0-14-48.17	0.99994724	1.00000395	0.99995119
RIVE	0-16-10.88	0.99994362	1.00000295	0.99994657
Project Averages:	0-12-37.94	0.99994786	1.00000329	0.99995115

APPENDIX D – STAR*NET NETWORK ADJUSTMENT REPORT

Adjusted Station Information

Adjusted Coordinates (Meters)

Station	N	E	Elev	Description
UCD1	596557.2693	2021690.2957	31.2765	UCD1
P268	589626.2665	2030856.1207	7.8651	P268
P271	610010.1580	2024846.1584	12.9705	P271
COD1	602678.4883	2029808.4221	6.4637	COD1
COY1	602665.9217	2026817.0537	8.3753	COY1
S16A	612168.5942	2030932.1104	8.4498	S16A
SM08	605652.9391	2030857.7158	6.4636	SM08
SM10	608811.6582	2029048.5679	9.4302	SM10
15	608777.2764	2029032.5965	10.8179	CONTROL
16	608793.8378	2028911.8157	10.0000	CONTROL AZ MARK
EX11	608789.4494	2028943.8232	7.4716	EX11
CR27	605717.8829	2026472.2946	9.0378	
1031	612222.3164	2025280.2267	10.1305	
SM11	611637.8060	2028521.6330	7.0497	
CAST	599681.9537	2031040.2322	5.1830	
SM09	605987.7372	2034076.6317	5.6389	
RIVE	608949.2090	2037236.2768	11.9588	

Adjusted Positions and Ellipsoid Heights (Meters)

Station	Latitude	Longitude	Ellip Ht	Geoid Ht
UCD1	38-32-10.449924	121-45-04.379784	0.0144	-31.2621
P268	38-28-24.681149	121-38-47.027881	-23.4309	-31.2960
P271	38-39-26.447882	121-42-52.326075	-17.8044	-30.7749
COD1	38-35-28.114860	121-39-28.223014	-24.4590	-30.9227
COY1	38-35-28.054244	121-41-31.836450	-22.5974	-30.9728
S16A	38-40-35.753116	121-38-40.255181	-22.2021	-30.6520
SM08	38-37-04.450378	121-38-44.384113	-24.3643	-30.8279
SM10	38-38-47.114446	121-39-58.691662	-21.3277	-30.7579
15	38-38-46.001294	121-39-59.357372	-19.9412	-30.7590
16	38-38-46.552748	121-40-04.349716	-20.7598	-30.7598
EX11	38-38-46.406630	121-40-03.026719	-23.2880	-30.7596
CR27	38-37-07.071749	121-41-45.661002	-21.8468	-30.8845
1031	38-40-38.146911	121-42-34.079974	-20.5680	-30.6985
SM11	38-40-18.832764	121-40-20.061430	-23.6302	-30.6799
CAST	38-33-50.779180	121-38-37.806580	-25.8065	-30.9894
SM09	38-37-14.880094	121-36-31.260494	-25.1625	-30.8014
RIVE	38-38-50.462947	121-34-20.065279	-18.7741	-30.7330
			Average:	-30.8548

APPENDIX D – STAR*NET NETWORK ADJUSTMENT REPORT

Adjusted GPS Vector Observations (Meters)

From To	Component	Adj Value	Residual	StdErr	StdRes
(V1 PostProcessed 04-SEP-2014 14:32:59.0 1037-001-201409.asc)					
P271	Delta-N	-7350.7564	0.0002	0.0037	0.1
COY1	Delta-E	1947.9035	-0.0007	0.0043	0.2
	Delta-U	-9.3378	-0.0001	0.0208	0.0
	Length	7604.4747			
(V2 PostProcessed 03-SEP-2014 19:18:44.0 1037-001-201409.asc)					
P271	Delta-N	-7350.7564	0.0004	0.0040	0.1
COY1	Delta-E	1947.9035	0.0017	0.0040	0.4
	Delta-U	-9.3378	-0.0270	0.0176	1.5
	Length	7604.4747			
(V3 PostProcessed 03-SEP-2014 21:14:44.0 1037-001-201409.asc)					
P271	Delta-N	-4297.5852	-0.0005	0.0052	0.1
CR27	Delta-E	1612.7244	0.0012	0.0071	0.2
	Delta-U	-5.6979	0.0092	0.0570	0.2
	Length	4590.2234			
(V4 PostProcessed 04-SEP-2014 17:13:59.0 1037-001-201409.asc)					
P271	Delta-N	-4297.5852	-0.0003	0.0033	0.1
CR27	Delta-E	1612.7244	0.0004	0.0033	0.1
	Delta-U	-5.6979	-0.0192	0.0261	0.7
	Length	4590.2234			
(V5 PostProcessed 03-SEP-2014 14:32:29.0 1037-001-201409.asc)					
P271	Delta-N	2210.9071	0.0003	0.0027	0.1
1031	Delta-E	441.0401	-0.0004	0.0022	0.2
	Delta-U	-3.1631	0.0063	0.0148	0.4
	Length	2254.4703			
(V6 PostProcessed 04-SEP-2014 19:09:29.0 1037-001-201409.asc)					
P271	Delta-N	2210.9071	0.0001	0.0028	0.0
1031	Delta-E	441.0401	-0.0001	0.0025	0.1
	Delta-U	-3.1631	-0.0126	0.0131	1.0
	Length	2254.4703			
(V7 PostProcessed 04-SEP-2014 13:46:59.0 1037-001-201409.asc)					
P271	Delta-N	-1211.7696	0.0003	0.0023	0.1
SM10	Delta-E	4198.8460	0.0014	0.0033	0.4
	Delta-U	-5.0190	-0.0029	0.0112	0.3
	Length	4370.2080			
(V8 PostProcessed 03-SEP-2014 18:54:29.0 1037-001-201409.asc)					
P271	Delta-N	-1211.7696	0.0021	0.0044	0.5
SM10	Delta-E	4198.8460	0.0035	0.0031	1.1
	Delta-U	-5.0190	-0.0567	0.0107	5.3*
	Length	4370.2080			
(V9 PostProcessed 03-SEP-2014 14:11:29.0 1037-001-201409.asc)					
P271	Delta-N	-1211.7696	0.0024	0.0031	0.8
SM10	Delta-E	4198.8460	0.0011	0.0025	0.4
	Delta-U	-5.0190	-0.0434	0.0128	3.4*
	Length	4370.2080			
(V10 PostProcessed 03-SEP-2014 15:05:29.0 1037-001-201409.asc)					
P271	Delta-N	1616.1754	0.0009	0.0042	0.2
SM11	Delta-E	3680.7745	-0.0008	0.0032	0.2
	Delta-U	-7.0918	0.0088	0.0259	0.3
	Length	4019.9719			
(V11 PostProcessed 04-SEP-2014 19:25:29.0 1037-001-201409.asc)					
P271	Delta-N	1616.1754	-0.0000	0.0042	0.0
SM11	Delta-E	3680.7745	-0.0005	0.0035	0.1

APPENDIX D – STAR*NET NETWORK ADJUSTMENT REPORT

Adjusted Observations and Residuals

=====

Adjusted Coordinate Observations (Meters)
 (Stations with Partially Fixed Coordinate Components)
 (Elevations Marked with (*) are Ellipsoid Heights)

Station	Component	Adj Coordinate	Residual	StdErr	StdRes
UCD1	N	596557.2693	0.0011	0.0010	1.1
	E	2021690.2957	0.0011	0.0010	1.1
	Elev	0.0144*	0.0004	0.0010	0.4
P268	N	589626.2665	0.0018	0.0010	1.8
	E	2030856.1207	-0.0008	0.0010	0.8
	Elev	-23.4309*	0.0001	0.0010	0.1
P271	N	610010.1580	-0.0008	0.0010	0.8
	E	2024846.1584	0.0006	0.0010	0.6
	Elev	-17.8044*	-0.0064	0.0020	3.2*
COD1	N	602678.4883	-0.0003	0.0010	0.3
	E	2029808.4221	-0.0003	0.0010	0.3
	Elev	-24.4590*	0.0010	0.0020	0.5
COY1	N	602665.9217	-0.0005	0.0010	0.5
	E	2026817.0537	0.0002	0.0010	0.2
	Elev	-22.5974*	0.0006	0.0020	0.3
S16A	N	612168.5942	-0.0004	0.0010	0.4
	E	2030932.1104	-0.0000	0.0010	0.0
	Elev	-22.2021*	-0.0001	0.0020	0.1
SM08	N	605652.9391	0.0003	0.0010	0.3
	E	2030857.7158	-0.0008	0.0010	0.8
	Elev	-24.3643*	0.0017	0.0020	0.8
SM10	N	608811.6582	-0.0010	0.0010	1.0
	E	2029048.5679	-0.0000	0.0010	0.0
	Elev	-21.3277*	0.0013	0.0020	0.7
15	N	608777.2764	0.0000	0.0100	0.0
	E	2029032.5965	0.0000	0.0100	0.0

Adjusted Measured Angle Observations (DMS)

From	At	To	Angle	Residual	StdErr	StdRes
16	15	EX11	0-00-01.00	0-00-00.00	4.76	0.0
16	15	SM10	107-06-31.00	0-00-00.00	12.67	0.0

Adjusted Measured Distance Observations (Meters)

From	To	Distance	Residual	StdErr	StdRes
15	16	121.9202	-0.0000	FIXED	0.0
15	EX11	89.6510	0.0000	0.0031	0.0
15	SM10	37.9206	0.0000	0.0030	0.0

Adjusted Zenith Observations (DMS)

From	To	Zenith	Residual	StdErr	StdRes
15	EX11	91-45-28.00	0-00-00.00	5.35	0.0
15	SM10	91-11-33.00	-0-00-00.00	11.89	0.0

APPENDIX D – STAR*NET NETWORK ADJUSTMENT REPORT

(V23 PostProcessed	03-SEP-2014 18:54:29.0	1037-001-201409.asc)				
SM10	Delta-N	-3165.5026	-0.0029	0.0041	0.7	
SM08	Delta-E	1797.6244	-0.0008	0.0029	0.3	
	Delta-U	-4.0774	-0.0471	0.0117	4.0*	
	Length	3640.3127				
(V24 PostProcessed	03-SEP-2014 14:11:29.0	1037-001-201409.asc)				
SM10	Delta-N	-3165.5026	0.0015	0.0029	0.5	
SM08	Delta-E	1797.6244	0.0010	0.0025	0.4	
	Delta-U	-4.0774	-0.0277	0.0125	2.2	
	Length	3640.3127				
(V25 PostProcessed	04-SEP-2014 21:01:44.0	1037-001-201409.asc)				
SM10	Delta-N	-2842.5232	-0.0007	0.0060	0.1	
SM09	Delta-E	5017.9052	0.0008	0.0100	0.1	
	Delta-U	-6.4414	-0.0030	0.0617	0.0	
	Length	5767.0922				
(V26 PostProcessed	03-SEP-2014 15:05:29.0	1037-001-201409.asc)				
SM10	Delta-N	2828.2165	-0.0020	0.0034	0.6	
SM11	Delta-E	-516.5828	0.0005	0.0027	0.2	
	Delta-U	-2.9522	0.0126	0.0206	0.6	
	Length	2875.0087				
(V27 PostProcessed	04-SEP-2014 19:25:29.0	1037-001-201409.asc)				
SM10	Delta-N	2828.2165	-0.0005	0.0035	0.1	
SM11	Delta-E	-516.5828	0.0005	0.0031	0.2	
	Delta-U	-2.9522	-0.0150	0.0175	0.9	
	Length	2875.0087				
(V28 PostProcessed	04-SEP-2014 17:13:59.0	1037-001-201409.asc)				
SM10	Delta-N	-3084.4557	-0.0005	0.0039	0.1	
CR27	Delta-E	-2587.7428	0.0007	0.0038	0.2	
	Delta-U	-1.7913	0.0220	0.0311	0.7	
	Length	4026.1996				
(V29 PostProcessed	03-SEP-2014 15:12:29.0	1037-001-201409.asc)				
SM11	Delta-N	522.1173	0.0010	0.0032	0.3	
S16A	Delta-E	2412.5126	-0.0005	0.0025	0.2	
	Delta-U	0.9510	-0.0062	0.0192	0.3	
	Length	2468.3647				
(V30 PostProcessed	04-SEP-2014 19:25:29.0	1037-001-201409.asc)				
SM11	Delta-N	522.1173	-0.0019	0.0032	0.6	
S16A	Delta-E	2412.5126	0.0018	0.0028	0.6	
	Delta-U	0.9510	-0.0317	0.0161	2.0	
	Length	2468.3647				
(V31 PostProcessed	02-SEP-2014 23:59:44.0	1037-001-201409.asc)				
UCD1	Delta-N	-6956.3437	-0.0027	0.0020	1.4	
P268	Delta-E	9147.0438	0.0026	0.0026	1.0	
	Delta-U	-33.7999	0.0033	0.0083	0.4	
	Length	11491.7479				
(V32 PostProcessed	03-SEP-2014 23:59:44.0	1037-001-201409.asc)				
UCD1	Delta-N	-6956.3437	-0.0029	0.0020	1.5	
P268	Delta-E	9147.0438	0.0023	0.0026	0.9	
	Delta-U	-33.7999	-0.0093	0.0078	1.2	
	Length	11491.7479				
(V33 PostProcessed	04-SEP-2014 14:32:59.0	1037-001-201409.asc)				
UCD1	Delta-N	6094.8219	0.0042	0.0037	1.2	
COY1	Delta-E	5143.6920	0.0017	0.0043	0.4	
	Delta-U	-27.6034	0.0045	0.0210	0.2	
	Length	7975.2858				

APPENDIX D – STAR*NET NETWORK ADJUSTMENT REPORT

	Delta-U	-7.0918	-0.0197	0.0197	1.0
	Length	4019.9719			
(V12 PostProcessed	03-SEP-2014 23:59:44.0	1037-001-201409.asc)			
P271	Delta-N	-13443.5655	-0.0024	0.0020	1.2
UCD1	Delta-E	-3198.2322	-0.0003	0.0025	0.1
	Delta-U	2.8103	-0.0110	0.0082	1.3
	Length	13818.7608			
(V13 PostProcessed	02-SEP-2014 23:59:44.0	1037-001-201409.asc)			
P271	Delta-N	-13443.5655	-0.0022	0.0019	1.2
UCD1	Delta-E	-3198.2322	-0.0009	0.0026	0.3
	Delta-U	2.8103	-0.0228	0.0076	3.0
	Length	13818.7608			
(V14 PostProcessed	03-SEP-2014 19:22:14.0	1037-001-201409.asc)			
COY1	Delta-N	2.4283	0.0008	0.0028	0.3
COD1	Delta-E	2991.5273	0.0023	0.0028	0.8
	Delta-U	-2.5622	0.0013	0.0146	0.1
	Length	2991.5294			
(V15 PostProcessed	04-SEP-2014 15:27:29.0	1037-001-201409.asc)			
COY1	Delta-N	2.4283	0.0006	0.0028	0.2
COD1	Delta-E	2991.5273	0.0017	0.0030	0.6
	Delta-U	-2.5622	-0.0206	0.0136	1.5
	Length	2991.5294			
(V16 PostProcessed	04-SEP-2014 15:14:29.0	1037-001-201409.asc)			
COY1	Delta-N	-2998.3944	-0.0002	0.0048	0.0
CAST	Delta-E	4213.2164	-0.0018	0.0034	0.5
	Delta-U	-5.3056	0.0121	0.0299	0.4
	Length	5171.2271			
(V17 PostProcessed	03-SEP-2014 19:18:44.0	1037-001-201409.asc)			
COY1	Delta-N	-2998.3944	-0.0048	0.0046	1.0
CAST	Delta-E	4213.2164	0.0059	0.0041	1.5
	Delta-U	-5.3056	-0.0203	0.0221	0.9
	Length	5171.2271			
(V18 PostProcessed	04-SEP-2014 17:13:59.0	1037-001-201409.asc)			
COY1	Delta-N	3053.2549	0.0034	0.0033	1.0
CR27	Delta-E	-334.4359	-0.0003	0.0032	0.1
	Delta-U	0.0090	0.0187	0.0271	0.7
	Length	3071.5163			
(V19 PostProcessed	03-SEP-2014 21:14:44.0	1037-001-201409.asc)			
COY1	Delta-N	3053.2549	0.0014	0.0042	0.3
CR27	Delta-E	-334.4359	-0.0023	0.0047	0.5
	Delta-U	0.0090	-0.0220	0.0268	0.8
	Length	3071.5163			
(V20 PostProcessed	03-SEP-2014 15:05:29.0	1037-001-201409.asc)			
1031	Delta-N	-594.9093	0.0007	0.0037	0.2
SM11	Delta-E	3239.7019	0.0000	0.0029	0.0
	Delta-U	-3.9117	0.0013	0.0226	0.1
	Length	3293.8732			
(V21 PostProcessed	04-SEP-2014 19:25:29.0	1037-001-201409.asc)			
1031	Delta-N	-594.9093	-0.0003	0.0038	0.1
SM11	Delta-E	3239.7019	0.0005	0.0033	0.2
	Delta-U	-3.9117	-0.0237	0.0178	1.3
	Length	3293.8732			
(V22 PostProcessed	04-SEP-2014 14:06:29.0	1037-001-201409.asc)			
SM10	Delta-N	-3165.5026	-0.0028	0.0022	1.3
SM08	Delta-E	1797.6244	0.0040	0.0032	1.2
	Delta-U	-4.0774	0.0012	0.0107	0.1
	Length	3640.3127			

APPENDIX D – STAR*NET NETWORK ADJUSTMENT REPORT

(V45 PostProcessed	04-SEP-2014 15:14:29.0	1037-001-201409.asc)				
SM08	Delta-N	-5971.9156	0.0013	0.0051	0.3	
CAST	Delta-E	159.2403	-0.0012	0.0036	0.3	
	Delta-U	-4.2478	0.0094	0.0308	0.3	
	Length	5974.0398				
(V46 PostProcessed	03-SEP-2014 19:18:14.0	1037-001-201409.asc)				
SM08	Delta-N	-5971.9156	-0.0050	0.0048	1.0	
CAST	Delta-E	159.2403	-0.0004	0.0043	0.1	
	Delta-U	-4.2478	-0.0183	0.0230	0.8	
	Length	5974.0398				
(V47 PostProcessed	03-SEP-2014 17:11:44.0	1037-001-201409.asc)				
SM08	Delta-N	322.2540	0.0008	0.0037	0.2	
SM09	Delta-E	3220.3539	-0.0001	0.0036	0.0	
	Delta-U	-1.6183	0.0299	0.0297	1.0	
	Length	3236.4378				
(V48 PostProcessed	04-SEP-2014 21:01:44.0	1037-001-201409.asc)				
SM08	Delta-N	322.2540	0.0001	0.0049	0.0	
SM09	Delta-E	3220.3539	0.0016	0.0040	0.4	
	Delta-U	-1.6183	0.0068	0.0121	0.6	
	Length	3236.4378				
(V49 PostProcessed	03-SEP-2014 17:05:29.0	1037-001-201409.asc)				
S16A	Delta-N	-3244.2216	0.0009	0.0051	0.2	
RIVE	Delta-E	6291.8603	-0.0022	0.0051	0.4	
	Delta-U	-0.4987	-0.0019	0.0392	0.0	
	Length	7079.0169				
(V50 PostProcessed	04-SEP-2014 21:14:44.0	1037-001-201409.asc)				
S16A	Delta-N	-3244.2216	-0.0026	0.0043	0.6	
RIVE	Delta-E	6291.8603	-0.0085	0.0067	1.3	
	Delta-U	-0.4987	-0.0499	0.0322	1.6	
	Length	7079.0169				
(V51 PostProcessed	03-SEP-2014 15:12:29.0	1037-001-201409.asc)				
S16A	Delta-N	75.8166	-0.0014	0.0049	0.3	
1031	Delta-E	-5651.9516	0.0012	0.0038	0.3	
	Delta-U	-0.8673	0.0090	0.0310	0.3	
	Length	5652.4602				
(V52 PostProcessed	04-SEP-2014 19:21:29.0	1037-001-201409.asc)				
S16A	Delta-N	75.8166	-0.0014	0.0049	0.3	
1031	Delta-E	-5651.9516	0.0016	0.0043	0.4	
	Delta-U	-0.8673	-0.0211	0.0233	0.9	
	Length	5652.4602				
(V53 PostProcessed	04-SEP-2014 21:01:44.0	1037-001-201409.asc)				
S16A	Delta-N	-6193.4399	-0.0027	0.0064	0.4	
SM09	Delta-E	3120.4721	-0.0020	0.0106	0.2	
	Delta-U	-6.7382	-0.0112	0.0660	0.2	
	Length	6935.1344				
(V54 PostProcessed	03-SEP-2014 17:11:44.0	1037-001-201409.asc)				
S16A	Delta-N	-6193.4399	0.0006	0.0041	0.2	
SM09	Delta-E	3120.4721	-0.0002	0.0041	0.0	
	Delta-U	-6.7382	-0.0291	0.0292	1.0	
	Length	6935.1344				
(V55 PostProcessed	04-SEP-2014 19:21:29.0	1037-001-201409.asc)				
S16A	Delta-N	-3349.7281	-0.0032	0.0038	0.8	
SM10	Delta-E	-1896.7596	-0.0014	0.0038	0.4	
	Delta-U	-0.2893	-0.0020	0.0186	0.1	
	Length	3849.4643				

APPENDIX D – STAR*NET NETWORK ADJUSTMENT REPORT

(V34 PostProcessed	03-SEP-2014 19:18:44.0	1037-001-201409.asc)				
UCD1	Delta-N	6094.8219	0.0065	0.0040	1.6	
COY1	Delta-E	5143.6920	0.0047	0.0040	1.2	
	Delta-U	-27.6034	-0.0246	0.0183	1.3	
	Length	7975.2858				
(V35 PostProcessed	04-SEP-2014 15:14:29.0	1037-001-201409.asc)				
UCD1	Delta-N	3099.1291	0.0032	0.0055	0.6	
CAST	Delta-E	9358.8291	-0.0049	0.0039	1.3	
	Delta-U	-33.4332	0.0121	0.0337	0.4	
	Length	9858.6714				
(V36 PostProcessed	03-SEP-2014 19:18:14.0	1037-001-201409.asc)				
UCD1	Delta-N	3099.1291	0.0040	0.0040	1.0	
CAST	Delta-E	9358.8291	0.0063	0.0045	1.4	
	Delta-U	-33.4332	-0.0178	0.0238	0.7	
	Length	9858.6714				
(V37 PostProcessed	03-SEP-2014 19:22:14.0	1037-001-201409.asc)				
COD1	Delta-N	-3001.2791	-0.0035	0.0039	0.9	
CAST	Delta-E	1220.5684	0.0014	0.0034	0.4	
	Delta-U	-2.1722	0.0210	0.0237	0.9	
	Length	3239.9797				
(V38 PostProcessed	04-SEP-2014 15:27:29.0	1037-001-201409.asc)				
COD1	Delta-N	-3001.2791	-0.0004	0.0040	0.1	
CAST	Delta-E	1220.5684	-0.0011	0.0029	0.4	
	Delta-U	-2.1722	-0.0036	0.0185	0.2	
	Length	3239.9797				
(V39 PostProcessed	03-SEP-2014 21:14:44.0	1037-001-201409.asc)				
SMO8	Delta-N	82.0340	-0.0054	0.0051	1.1	
CR27	Delta-E	-4385.3494	-0.0023	0.0068	0.3	
	Delta-U	1.0114	0.0062	0.0549	0.1	
	Length	4386.1167				
(V40 PostProcessed	04-SEP-2014 17:13:59.0	1037-001-201409.asc)				
SMO8	Delta-N	82.0340	-0.0001	0.0035	0.0	
CR27	Delta-E	-4385.3494	0.0011	0.0038	0.3	
	Delta-U	1.0114	-0.0043	0.0272	0.2	
	Length	4386.1167				
(V41 PostProcessed	04-SEP-2014 14:32:59.0	1037-001-201409.asc)				
SMO8	Delta-N	-2971.3896	-0.0001	0.0033	0.0	
COY1	Delta-E	-4052.4597	0.0008	0.0038	0.2	
	Delta-U	-0.2129	0.0006	0.0185	0.0	
	Length	5025.0956				
(V42 PostProcessed	03-SEP-2014 19:18:44.0	1037-001-201409.asc)				
SMO8	Delta-N	-2971.3896	-0.0027	0.0035	0.8	
COY1	Delta-E	-4052.4597	-0.0028	0.0035	0.8	
	Delta-U	-0.2129	-0.0261	0.0161	1.6	
	Length	5025.0956				
(V43 PostProcessed	03-SEP-2014 19:22:14.0	1037-001-201409.asc)				
SMO8	Delta-N	-2970.4759	-0.0011	0.0029	0.4	
COD1	Delta-E	-1060.9306	-0.0016	0.0026	0.6	
	Delta-U	-0.8765	-0.0032	0.0147	0.2	
	Length	3154.2513				
(V44 PostProcessed	04-SEP-2014 15:27:29.0	1037-001-201409.asc)				
SMO8	Delta-N	-2970.4759	0.0006	0.0029	0.2	
COD1	Delta-E	-1060.9306	0.0016	0.0031	0.5	
	Delta-U	-0.8765	-0.0168	0.0142	1.2	
	Length	3154.2513				

APPENDIX D – STAR*NET NETWORK ADJUSTMENT REPORT

Adjusted Bearings (DMS) and Horizontal Distances (Meters)

=====

(Relative Confidence of Bearing is in Seconds)

From	To	Grid Bearing	Grid Dist Grnd Dist	95% RelConfidence		
				Brg	Dist	PPM
15	16	N82-11-32.53W	121.9110 121.9175	137.07	0.0000	0.3822
15	EX11	N82-11-31.54W	89.6041 89.6088	137.57	0.0075	83.9499
15	SM10	N24-54-58.45E	37.9103 37.9123	133.52	0.0070	185.6037
1031	P271	S11-06-05.39W	2254.3425 2254.4686	0.29	0.0036	1.6145
1031	S16A	S89-27-19.47E	5652.1390 5652.4599	0.14	0.0034	0.6095
1031	SM11	S79-46-40.53E	3293.6860 3293.8718	0.26	0.0035	1.0720
CAST	COD1	N22-20-47.39W	3239.8419 3239.9794	0.21	0.0037	1.1303
CAST	COY1	N54-45-22.14W	5171.0059 5171.2261	0.15	0.0034	0.6576
CAST	P268	S01-02-56.12W	10057.3726 10057.7026	0.07	0.0039	0.3829
CAST	SM08	N01-45-02.98W	5973.7742 5974.0396	0.11	0.0038	0.6324
CAST	UCD1	S71-31-14.62W	9858.2435 9858.6375	0.08	0.0034	0.3470
COD1	COY1	S89-45-33.50W	2991.3948 2991.5288	0.17	0.0024	0.8089
COD1	SM08	N19-25-52.52E	3154.1044 3154.2513	0.15	0.0025	0.7853
COY1	CR27	N06-26-41.96W	3071.3720 3071.5163	0.26	0.0037	1.2135
COY1	P271	N15-01-18.95W	7604.0933 7604.4731	0.07	0.0023	0.3024
COY1	SM08	N53-31-36.20E	5024.8605 5025.0953	0.09	0.0025	0.4882
COY1	UCD1	S40-00-19.61W	7974.9157 7975.2537	0.06	0.0025	0.3151
CR27	P271	N20-44-57.42W	4589.9831 4590.2216	0.17	0.0037	0.8041
CR27	SM08	S89-09-05.64E	4385.9021 4386.1160	0.18	0.0038	0.8756
CR27	SM10	N39-47-06.34E	4025.9943 4026.1995	0.19	0.0040	0.9924
P268	UCD1	N52-54-15.12W	11491.3510 11491.7240	0.04	0.0024	0.2103
P271	SM10	S74-04-55.91E	4369.9711 4370.2066	0.10	0.0021	0.4894
P271	SM11	N66-06-51.52E	4019.7452 4019.9677	0.17	0.0030	0.7536
P271	UCD1	S13-12-07.50W	13818.0926 13818.7493	0.03	0.0021	0.1550
RIVE	S16A	N62-56-51.72W	7078.6267 7079.0161	0.20	0.0055	0.7776
RIVE	SM09	S46-51-15.57W	4330.5511	0.22	0.0067	1.5371

APPENDIX D – STAR*NET NETWORK ADJUSTMENT REPORT

(V56 PostProcessed	03-SEP-2014 15:12:29.0	1037-001-201409.asc)			
S16A	Delta-N	-3349.7281	-0.0005	0.0034	0.1
SM10	Delta-E	-1896.7596	0.0007	0.0027	0.2
	Delta-U	-0.2893	-0.0163	0.0151	1.1
	Length	3849.4643			
(V57 PostProcessed	04-SEP-2014 15:14:29.0	1037-001-201409.asc)			
P268	Delta-N	10055.2196	0.0017	0.0055	0.3
CAST	Delta-E	223.2452	-0.0002	0.0039	0.1
	Delta-U	-10.3280	0.0278	0.0343	0.8
	Length	10057.7028			
(V58 PostProcessed	03-SEP-2014 19:18:14.0	1037-001-201409.asc)			
P268	Delta-N	10055.2196	0.0036	0.0041	0.9
CAST	Delta-E	223.2452	0.0011	0.0045	0.2
	Delta-U	-10.3280	-0.0209	0.0256	0.8
	Length	10057.7028			
(V59 PostProcessed	03-SEP-2014 17:11:44.0	1037-001-201409.asc)			
RIVE	Delta-N	-2946.7218	-0.0020	0.0043	0.5
SM09	Delta-E	-3173.7044	-0.0031	0.0043	0.7
	Delta-U	-7.8596	0.0267	0.0355	0.8
	Length	4330.7772			
(V60 PostProcessed	04-SEP-2014 21:14:44.0	1037-001-201409.asc)			
RIVE	Delta-N	-2946.7218	-0.0002	0.0037	0.0
SM09	Delta-E	-3173.7044	-0.0026	0.0043	0.6
	Delta-U	-7.8596	-0.0348	0.0239	1.5
	Length	4330.7772			

APPENDIX D – STAR*NET NETWORK ADJUSTMENT REPORT

Error Propagation

=====

Station Coordinate Standard Deviations (Meters)

Station	N	E	Elev
UCD1	0.000718	0.000771	0.000968
P268	0.000829	0.000867	0.000984
P271	0.000703	0.000721	0.001779
COD1	0.000809	0.000802	0.001914
COY1	0.000749	0.000756	0.001882
S16A	0.000850	0.000821	0.001937
SMO8	0.000731	0.000728	0.001844
SM10	0.000728	0.000716	0.001808
15	0.004991	0.009154	0.002838
16	0.036994	0.004977	0.000000
EX11	0.028416	0.006769	0.003668
CR27	0.001499	0.001520	0.011151
1031	0.001556	0.001354	0.007579
SM11	0.001393	0.001203	0.007017
CAST	0.001463	0.001255	0.007831
SMO9	0.001940	0.001902	0.009146
RIVE	0.002461	0.002671	0.015661

Station Coordinate Error Ellipses (Meters)
Confidence Region = 95%

Station	Semi-Major Axis	Semi-Minor Axis	Azimuth of Major Axis	Elev
UCD1	0.001891	0.001754	79-43	0.001898
P268	0.002122	0.002027	84-26	0.001929
P271	0.001770	0.001715	70-44	0.003487
COD1	0.002030	0.001912	40-17	0.003751
COY1	0.001913	0.001770	48-24	0.003688
S16A	0.002085	0.002005	13-58	0.003797
SMO8	0.001832	0.001737	42-42	0.003614
SM10	0.001786	0.001747	20-55	0.003544
15	0.024477	0.007223	114-55	0.005562
16	0.091157	0.006216	173-23	0.000000
EX11	0.070845	0.009660	168-56	0.007190
CR27	0.003825	0.003559	50-39	0.021856
1031	0.003809	0.003313	179-32	0.014854
SM11	0.003412	0.002942	174-53	0.013754
CAST	0.003581	0.003072	1-43	0.015349
SMO9	0.005241	0.004095	42-39	0.017925
RIVE	0.007201	0.005213	52-34	0.030694

APPENDIX D – STAR*NET NETWORK ADJUSTMENT REPORT

S16A	SM09	S26-57-53.25E	4330.7724 6934.7680	0.15	0.0042	0.6104
S16A	SM10	S29-17-46.82W	6935.1338 3849.2533	0.13	0.0025	0.6465
S16A	SM11	S77-34-53.86W	3849.4642 2468.2255	0.29	0.0030	1.2100
SM08	SM09	N84-03-43.34E	2468.3643 3236.2802	0.30	0.0047	1.4669
SM08	SM10	N29-48-06.51W	3236.4377 3640.1268	0.13	0.0022	0.5970
SM09	SM10	N60-40-48.16W	3640.3114 5766.7977	0.19	0.0043	0.7476
SM10	SM11	N10-33-41.47W	5767.0909 2874.8515	0.21	0.0035	1.2037
			2875.0078			

The OPUS Projects adjustment produced a SEUW of 0.500, which is in the middle of the acceptable range. The OPUS Projects adjustment report is attached as Appendix B.

Following the OPUS Projects adjustment, GPS data taken at 14 stations (including the CORS P268, P271 and UCD1) was processed in Trimble Business Center (TBC) v2.81 using precise orbits and NGS absolute antenna models. This was done primarily to produce vector data for use in a combined GPS-terrestrial adjustment using Star*Net v6.0. However, a minimally-constrained adjustment of the GPS data was performed in TBC to ensure data quality. This adjustment produced a SEUW of 1.96, indicating that the accuracy of the data is somewhat lower than predicted by the baseline processor. However, the Trimble baseline processor is known to be optimistic, and this value is acceptable for the project. (Note that the acceptable SEUW range for OPUS Projects is based on a different set of parameters and is not directly comparable to the SEUW value produced by TBC.) The minimally-constrained adjustment report is attached as Appendix C.

The adjusted positions from the OPUS Projects adjustment for the 8 stations closest to the project area were used as constraints in the Star*Net adjustment, using the standard errors for these station positions (latitude, longitude and ellipsoid height) as reported by OPUS Projects. This adjustment incorporated both GPS and terrestrial measurements, and produced a SEUW of 1.041 after scaling the GPS vector standard errors by the SEUW of the TBC adjustment (1.96).

A high-resolution hybrid geoid model (GEOID12A) produced by NGS was applied during the adjustment to produce NAVD88 orthometric heights (elevations).

The final positions from the Star*Net adjustment are shown in the tables below. Values are shown in geographic format with ellipsoid height in meters (Table C), California Coordinate System of 1983 (CCS83) meters (Table D) and CCS83 feet (Table E). The complete Star*Net adjustment report is attached as Appendix D. Note that there is no Table A or Table B so that table designations remain consistent between this report and the June report, and that Tables C, D and E do not include positions for LNC2, P267, PLSB and SACR, as these were not used in the Star*Net adjustment.

APPENDIX D – STAR*NET NETWORK ADJUSTMENT REPORT

Relative Error Ellipses (Meters)
Confidence Region = 95%

Stations From	To	Semi-Major Axis	Semi-Minor Axis	Azimuth of Major Axis	Vertical
15	16	0.081014	0.000047	7-48	0.005562
15	EX11	0.059760	0.007522	7-48	0.004557
15	SM10	0.024540	0.007036	114-55	0.004286
1031	P271	0.003658	0.003127	0-02	0.014715
1031	S16A	0.003973	0.003444	178-55	0.015068
1031	SM11	0.004163	0.003494	177-12	0.017284
CAST	COD1	0.003747	0.003223	2-13	0.015519
CAST	COY1	0.003764	0.003266	4-48	0.015591
CAST	P268	0.003852	0.003465	5-07	0.015433
CAST	SM08	0.003782	0.003276	3-48	0.015594
CAST	UCD1	0.003752	0.003350	5-44	0.015425
COD1	COY1	0.002545	0.002289	44-36	0.005147
COD1	SM08	0.002507	0.002280	41-18	0.005105
COY1	CR27	0.003926	0.003630	49-13	0.021921
COY1	P271	0.002457	0.002277	54-32	0.005017
COY1	SM08	0.002456	0.002228	46-59	0.005082
COY1	UCD1	0.002539	0.002325	60-40	0.004127
CR27	P271	0.003911	0.003669	52-06	0.021986
CR27	SM08	0.003958	0.003652	51-55	0.021996
CR27	SM10	0.004001	0.003713	47-39	0.022040
P268	UCD1	0.002540	0.002258	84-57	0.002665
P271	SM10	0.002185	0.002136	27-50	0.004761
P271	SM11	0.003456	0.002970	175-52	0.013864
P271	UCD1	0.002349	0.002109	81-59	0.003876
RIVE	S16A	0.007083	0.005049	53-13	0.030667
RIVE	SM09	0.006669	0.004690	51-44	0.029732
S16A	SM09	0.005229	0.004095	43-45	0.018131
S16A	SM10	0.002499	0.002356	13-38	0.005093
S16A	SM11	0.003473	0.002978	174-49	0.013871
SM08	SM09	0.005252	0.004060	41-40	0.017762
SM08	SM10	0.002247	0.002160	37-10	0.004856
SM09	SM10	0.005356	0.004249	42-15	0.018191
SM10	SM11	0.003465	0.002977	175-32	0.013910



Privileged & Confidential Attorney Work Product
Prepared at the Request of Counsel

T E C H N I C A L M E M O R A N D U M

TO: John Herrick, South Delta Water Agency
Dante Nomellini, Central Delta Water Agency

DATE: December 1, 2014

FROM: Jack Dahl, EIT
Nathan Jacobsen, PE
John Lambie, PE, PG, CEG

PROJ. NO. 0611-001-01

SUBJECT: __Review and Comments to Long-Term Water Transfers Environmental Impact Statement/Environmental Impact Report (EIS/EIR) - Public Draft

Executive Summary of Comments

The analysis in the EIS/EIR of Groundwater Substitution Measures considered within Alternatives 2 and 3 for Long-Term Water Transfers does not properly account the water available. The analysis of the Groundwater Substitution Measures in the EIS/EIR:

- improperly quantifies the groundwater depletions that would result from groundwater extraction;
- fails to properly account for the timing and quantity of groundwater flow that would have accreted to the rivers as baseflow absent the groundwater extraction;
- fails to accurately quantify the effects of exfiltration from the river to groundwater; and
- as a result significant quantities of water are being double counted as between available surface water and extracted groundwater.

The proposed mitigation measures are inadequate to offset the impacts, in some cases this is due to the inaccurate accounting of water and in other cases it is because the proposed mitigation is too ill-defined to provide substantive protection against impacts.

Groundwater Resources

The SACFEM 2013 groundwater model utilized for analysis in the EIS/EIR for Groundwater Substitution Measures does not properly account the losses of water in the rivers. This is true due to a number of deficiencies in the model's simulation code, MicroFEM and the SACFEM2013 model's construction.

- SACFEM2013 uses a river stage that does not vary over each time step which in effect makes the river an infinite source of water for each time step.

1

2

- SACFEM2013 does not accurately account the losses of water in the rivers because it does not contain a mathematical algorithm for accounting the flow or quantity of water in the rivers. 3
- SACFEM2013 does not accurately account the water because it treats flow between the river and aquifer as fully-saturated flow even when the model conditions recognize that hydraulically they are detached. 4
- SACFEM2013 has been configured such that extraction from Groundwater Substitution Measures are hydraulically isolated from the river (for example a vertical anisotropy of 500:1 in hydraulic conductivity at the wells in the model substantially isolates them from the rivers) 5
- SACFEM2013 does not represent accurately the depletions to groundwater that must be refilled by natural recharge or other sources due to its handling the rivers as infinite sources during each model time interval 6

SACFEM2013 is not well calibrated to actual conditions of groundwater elevation near rivers and streams. Due to its lack of calibration to actual groundwater elevation conditions, the predictive outcomes are not reliable as a basis for assessing the locations of impact and the degree of impact to Water Supply, Groundwater Resources, Water Quality, and Terrestrial Resource considerations. 7

Neither the quantity of water nor the timing of its removal from surface water is calculated correctly in SACFEM2013 due to the structural deficiencies identified in our review. One of the essential needs in an EIS/EIR on Groundwater Substitution Measures is accurate estimating of the timing of impacts to the flowing rivers and streams; SACFEM2013 does not provide accurate monthly estimates of when peak streamflow depletions will occur if Groundwater Substitution Measures are imposed in large part because of the hydraulic isolation of the pumping from the rivers configured into the model. 8

The magnitude of groundwater depletion is underestimated in SACFEM2013 due to its use of infinite river sources. 9

The Proposed Mitigation GW-1 for aquifer desaturation resulting from Groundwater Substitution Measures, GW-1, will not adequately mitigate the impacts to groundwater users in the Seller's Area. This is due in part to the improper accounting of the exchange of surface water and groundwater in SACFEM2013 which attributes too much of the groundwater elevation variability to seasonal recharge and discharge and does not attribute enough of the variability to long term desaturation. However, the Proposed Mitigation, GW-1, will not adequately mitigate for changes in groundwater storage due to the mitigation measure's reliance upon local groundwater-subbasin management-objectives; those objectives are insufficiently quantified and thereby cannot enable timely mitigation of project impacts from Groundwater Substitution Measures. 10

The mitigation proposed for decreases in groundwater saturation of the uppermost aquifer, GW-1, are inadequately considered. SACFEM2013 does not correctly calculate the drawdown of the unsaturated aquifer and its corresponding increase in the weight of the overburden on under consolidated lithologic layers. This will result in greater impacts from Groundwater Substitution Measures than are recognized in the EIS/EIR due to inelastic subsidence and the resulting permanent loss of aquifer storage in the Seller's Area. The proposed mitigation, GW-1, will only recognize or acknowledge inelastic subsidence 11

due to Groundwater Substitution Measures after it has occurred; thus it cannot restore or offset the permanent impact of subsidence.

11

Water Supply

The “post-processing tool” referred to under evaluations of Water Supply for Water Operations Assessment does not properly account for water as it uses SACFEM2013, CalSim II, and a spreadsheet model called the Transfer Operations Model (TOM). The potential impacts to Water Supply from Groundwater Substitution Measures do not properly account the water the sources available and depleted in the Water Operations Assessment.

12

The CalSim II model utilized for analysis in the EIS/EIR does not properly account the losses of water in the rivers nor the quantities of accretionary flow of groundwater to rivers within the area modeled. Calsim II provides limited useful information to assess potential surface water impacts as the model contains unfounded assumptions, errors, and outdated simulation codes. The very poor precision of the surface water delivery model (CalSim II) used for the baseline assessment on quantities of water moving in and around the CVP and SWP leads to problems in accounting for water losses due to existing groundwater extraction and proposed groundwater extraction as Groundwater Substitution Measures.

13

TOM is utilized in the EIS/EIR to assess Impacts to Water Supply from Groundwater Substitution Measures does not and by virtue of its underpinnings of SACFEM2013 and CalSim II cannot properly account the losses of water in the rivers induced by Groundwater Substitution Measures. TOM simulates water made available under each transfer mechanism, subject to various constraints. TOM uses an assumed priority for transfer mechanisms used to make water available under Project alternatives in the following order:

14

- Groundwater substitution – for alternatives that include this mechanism
- Reservoir release
- Conserved water
- Crop idling – for alternatives that include this mechanism

Priorities for transfer mechanisms are necessary to develop groundwater pumping inputs to SACFEM2013 and simulate all transfers in TOM. Thus TOM appears to bookkeep errors in available water derived in SACFEM2013 and CalSim II. It takes input from SACFEM2013 and CalSim II to bookkeep their inaccurate information but provides no feedback to those models

15

The methodology by which Groundwater Substitution Measures for Long-Term Water Transfers are being considered and analyzed within the EIS/EIR, improperly accounts quantities of water and as a result significant quantities of water are being double counted as between available surface water and extracted groundwater.

16

Due to the improper accounting of water in Water Supply, the proposed mitigation, WS-1, is inadequate to mitigate the impacts to water availability and water flows into and through the Delta during three important periods of time: (1) the period of Groundwater Substitution pumping, April thru September; (2) the Water Transfers window, July thru September; and, (3) the period following the Water Transfers window, October to April.

17

Due to the lack of a specific formulation for the proposed Water Supply mitigation, WS-1, it is unpredictable how the mitigation will be applied. The EIS/EIR references Draft documents on Technical Information for Preparing Water Transfer Proposals (October 2013).¹ Those documents identify the need for estimating the effects of transfer operations on streamflow and describe the use of a streamflow depletion factor; however they provide no basis for Project Agency approval nor for transfer proponents to submit site-specific technical analysis supporting a streamflow depletion factor. That document which is completely relied upon in establishing proposed mitigation, WS-1, states that:

“Project Agencies are developing tools to more accurately evaluate the impacts of groundwater substitution transfers on streamflow. These tools may be implemented in the near future and may include a site-specific analysis that could be applied to each transfer proposal.”²

This future action provides no established or predictable basis for the mitigation of streamflow depletions due to Groundwater Substitution Measures. Due to the improper accounting of water in both the groundwater and surface water supply models utilized for Water Supply analysis, reliance upon these models or the analysis in this EIS/EIR by the Project Agencies would result in inappropriate estimation of the streamflow depletion factors (SDF) utilized. Examples of appropriate methodologies for quantifying SDF for Water Supply are provided in Appendices A and B. They result in short-term SDF ranging from 8% to 22% of the Groundwater Substitution Measures after the onset of pumping proposed in the EIS/EIR and long-term cumulative SDF ranging from 34% to 108.5% of annual pumping based on evaluation of the 6-year drought from 1987 to 1992.

The mitigation proposed for loss of Water Supply, WS-1, due to Groundwater Substitution transfers is insufficient. It does not adequately account for the impact from the resulting reductions of water available in the rivers and groundwater due to the improper accounting of water in the EIS/EIR analyses. As detailed in our analysis the mitigation measure proposed has no basis in fact, and if it did the project proponents would find that mitigation of the impacts from Groundwater Substitution Measures are not likely to meet the Project Purpose and Need and the Project Objectives.

Water Quality

Groundwater Substitution Measures for Long-Term Water Transfers effects on Delta outflows and water quality are not properly considered in the EIR/EIS. The EIS/EIR rates the effects on Delta outflows and the impact to Delta Water Quality as Less Than Significant based on improper accounting of water. The effects and impacts are likely to be Significant and thus will require mitigation.

Reservoir Releases for meeting regulatory requirements and or deliveries to Project Contractors may be diminished by streamflow depletions from current and proposed pumping conditions in areas where groundwater saturation falls below the adjoining river stage. These depletions of water available for transfer via Reservoir Releases are not quantified in the EIS/EIR. The effect of these baseline conditions impacts the availability of water to be transferred down the Sacramento River and through the

¹ Department of Water Resources and Bureau of Reclamation, 2013. DRAFT Technical Information for Preparing Water Transfer Proposals – Information to Parties Interested in Making Water Available for Water Transfers in 2014, October.

² Ibid, at p. 33.

Sacramento San-Joaquin River Delta to the CVP and SWP pumping stations that pump water south via their respective aqueducts, the Delta-Mendota Canal, and the California Aqueduct.

19

Terrestrial Resources

Terrestrial Resource impacts are not properly accounted in the EIS/EIR due in part to the imprecision and inability of the models to assess dehydration of the soils and groundwater aquifer adjoining both small streams and large rivers.

The Proposed Mitigation, GW-1, for potential impacts to Terrestrial Resources is insufficient to mitigate the impacts since it too is not sufficiently quantified in the EIS/EIR nor in the Groundwater Management Plans (GWMPs) referenced. Existing GWMPs do not contain quantified year on year metrics for subbasin depletion and refill. These GWMPs do not identify acceptable ranges of groundwater elevations for short-term or long-term groundwater that will to sustain primary functions like support for natural riparian communities upon which several endangered species rely.

20

Summary of Impact Statements Addressed from the Review Performed of the EIS/EIR Analyses

The fundamental concept of water accounting errors in the models and conceptualizations applied to six specific evaluations made in the EIS/EIR are addressed herein under four topic headings Groundwater Resources, Water Supply, Water Quality and Terrestrial Resources.

Potential Impact Statements from Table ES-4	Related Alternative(s)	Significance to CEQA	Proposed Mitigation	Significance After Mitigation Pursuant to CEQA
Groundwater substitution transfers could cause a reduction in groundwater levels in the Seller Service Area.	2, 3	S	GW-1: Mitigation and Monitoring Plans	LTS
Groundwater substitution transfers could cause subsidence in the Seller Service Area.	2, 3	S	GW-1: Mitigation and Monitoring Plans	LTS
Groundwater substitution transfers could decrease flows in surface water bodies following a transfer while groundwater basins recharge, which could decrease pumping at Jones and Banks Pumping Plants and/or require additional water releases from upstream CVP reservoirs.	2, 3	S	WS-1: Streamflow Depletion Factor	LTS

Potential Impact Statements from Table ES-4	Related Alternative(s)	Significance to CEQA	Proposed Mitigation	Significance After Mitigation Pursuant to CEQA
Water transfers could change Delta outflows and could result in water quality impacts.	2, 3, 4	LTS	None	LTS
Groundwater substitution could reduce stream flows supporting natural communities in small streams	2, 3	S	GW-1	LTS
Transfer actions could alter flows in large rivers, altering habitat availability and suitability associated with these rivers	2, 3, 4	LTS	None	LTS



Detailed Comments to EIS/EIR Analyses

Groundwater Resources

The EIS/EIR evaluates at Section 3.3.2 on Environmental Consequences/Environmental Impacts on Groundwater Levels from the Long-Term Water Transfers lists: (1) increased groundwater pumping costs due to increased pumping depth (i.e. increased depth to water in an extraction well); (2) decreased yields from groundwater due to reduction in the saturated thickness of the aquifer; (3) lowered groundwater table elevation to a level below the vegetative root zone, which could result in environmental effects. It then sets out to evaluate Item (1) under Regional Economics and (3) under Vegetation and Wildlife. Further it states that for Environmental Consequences/Environmental Impacts on Land Subsidence that excessive groundwater extraction from confined and unconfined aquifers could lower groundwater levels and decrease pore-water pressure. It notes that compression of fine-grained deposits is largely permanent and lists various negative consequences that could result.

Our review finds the evaluation in the EIS/EIR of impacts to Groundwater Resources from Groundwater Substitution Measures does not properly account for water and as a result is either inaccurate or insufficient to evaluate the potential environmental impacts associated with Groundwater Substitution.

Potential Impact Statements from Table ES-4	Related Alternative(s)	Significance to CEQA	Proposed Mitigation	Significance After Mitigation Pursuant to CEQA
Groundwater substitution transfers could cause a reduction in groundwater levels in the Seller Service Area.	2, 3	S	GW-1: Mitigation and Monitoring Plans	LTS

The two assessment methods utilized for Groundwater Resources in the EIS/EIR are a numerical groundwater model, SACFEM2013, and a qualitative assessment for groundwater conditions in the Redding Area Groundwater Basin outside of the numerical groundwater limits.

The SACFEM 2013 groundwater model does not properly account water in an integrated groundwater to surface water system. This is due in part to the shortcomings in the underlying simulation code used, MicroFEM, to construct the SACFEM 2013 groundwater model.³ The MicroFEM simulation code selected for evaluation of the significance of potential impacts to groundwater lacks some essential mathematics for evaluation of the issues presented by Groundwater Substitution Measures. MicroFEM is a simulation code only for fully saturated groundwater systems whereas to evaluate the potential impacts and

³ The following terms, referenced herein, are typical of industry nomenclature: Algorithm - an operation or calculation (e.g., the Darcy equation); Simulation Code - a sequence of programming language commands that encapsulates one or more algorithms (e.g., California DWR's IWFM program); and, Model - an application of a simulation code to a site-specific question (e.g., in this EIS/EIR-evaluation the use of MicroFEM and its construction into the groundwater model SACFEM2013)

21

22

effects of groundwater extraction near rivers in the Sacramento River Basin it is necessary to properly formulate the discharge of water from the rivers when the river at the bottom of its streambed hydraulically detaches from the groundwater aquifer due to aquifer desaturation. While MicroFEM mathematically notes the transition from saturated to unsaturated it calculates the condition of discharge as if it is fully saturated. This is incorrect and produces substantive miscalculation of the rate and quantity of movement of surface water into groundwater and thus the magnitude of the resulting groundwater depletion.

As can be seen in the following illustration (Figure 1) aquifer desaturation and streamflow detachment, will influence the rate of change in groundwater elevations, groundwater flow, and groundwater interaction with surface water bodies, particularly rivers and streams. We address streamflow under Water Supply.

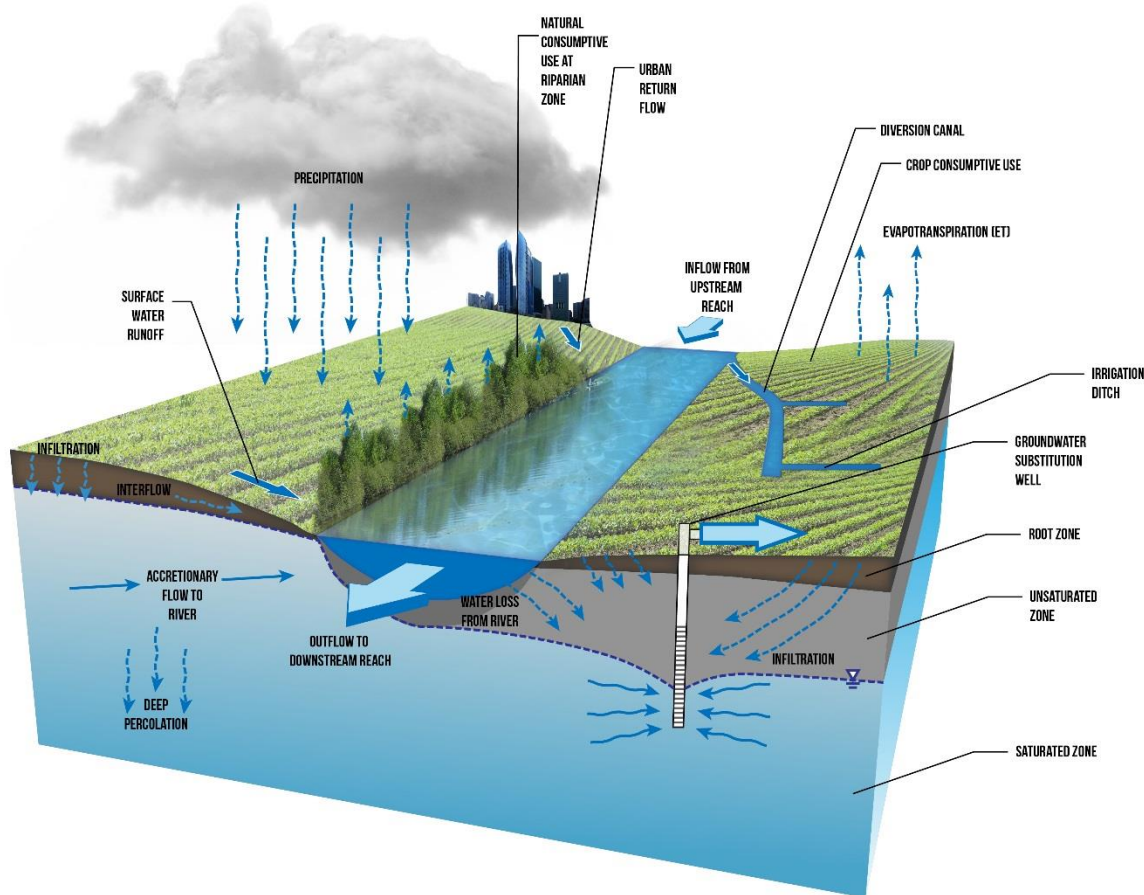

Figure 1 Groundwater Surface Water Interactions in the Hydrologic Cycle

The MicroFEM simulation code lacks the algorithm that would account the water loss from the river under unsaturated and partially saturated conditions. In order to properly account water in the groundwater system and represent the changes in the groundwater elevations as well as the streamflow depletion from the rivers and streams induced by Groundwater Substitution Measures, unsaturated or

partially saturated groundwater flow algorithms are essential components of the simulation code and/or the quantitative analysis. Since the MicroFEM simulation code does not have proper algorithms to represent streamflow detachment and the resulting flux to groundwater, then as a result neither does SACFEM2013 model, the model upon which Groundwater Resource evaluations are based.

22

As far as potential impacts to river stage heights induced by decreases in groundwater elevations from Groundwater Substitution Measures, MicroFEM has no algorithm to calculate a change in river stage height that governs the rate of accretion or depletion to the river. Thus calculation of fluxes into and out of a river are inaccurate. They are either overestimated or underestimated based on the relative head difference between groundwater and surface water. The flow into or out of the groundwater system (called groundwater surface-water flux hereinafter) is never correct in MicroFEM due to this missing algorithm and capability in the simulation code.

For each time step the SACFEM2013 model has a user-input river stage that is invariant for the monthly time step. This results in substantive problems in properly accounting the depletion of water in the groundwater aquifer and in the groundwater surface-water flux. First with regard to accounting the depletion of groundwater SACFEM2013 does not account for the origin of surface water flowing into the groundwater domain. Surface water flowing into the groundwater domain during each monthly time-step is treated as an infinite source of water; there is no formulation of river flow in the MicroFEM simulation code and hence the SACFEM2013 model has no river flow accounting to provide proper accounting of this lost surface water (That water loss accounting appears to be attempted later under the Transfer Operations Model which we address under Water Supply). A useful publication from the U.S. Geological Survey (USGS) from 1998, Ground Water and Surface Water A Single Resource, identifies that the hydrologic cycle demonstrates that groundwater surface-water flux behaves dynamically and that groundwater is not a source but rather the system of surface water and groundwater is a finite resource defined and governed by local and regional hydrologic and hydrogeologic conditions.⁴ This dynamic interaction of groundwater surface-water fluxes within the context that it is finite in quantity and temporally controlled is not the manner in which groundwater modeling has been done for use in the EIS/EIR. Since the source of surface water in SACFEM2013 that satisfies the model estimated drawdown is mathematically infinite, an improper accounting of water available in the system occurs. This results in the double counting of available water as between available groundwater for substitution transfer and available surface water to transfer. In summary the accounting of surface water available to recharge an aquifer in SACFEM2013 is not correct due to the fundamental construct of the model.

23

Due to the SACFEM2013 model requirement of groundwater surface-water flux being calculated as a fully saturated flow condition, groundwater surface-water flux where the model calculated head near a river reach is below the bottom of the streambed is not properly calculated in SACFEM2013. Rates of inflow to groundwater where this occurs within the model domain for a particular model stress period are overestimated due to both the incorrect mathematical formulation as fully saturated flow and the invariant stage height in that river reach for that stress period (or the following stress period if there were some model carryover of surface water depletions). Furthermore the underestimation of groundwater depletion from that same stress period is error that is carried over to the next stress

24

⁴ Winter, T.C., J.W. Harvey, O.L. Franke, and W.M. Alley 1998. Ground Water and Surface Water A Single Resource, USGS Circular 1139, pp. 79, p. 2.

period. This cumulative error in accounting the temporal depletion of groundwater in SACFEM2013 is significant because the model then subsequently does not have correct quantification of the amount of required refill water to replenish groundwater from both natural recharge and delivery and application of irrigation water. Thus there are problems in accounting water correctly in the connected groundwater and surface water system due to errors in SACFEM2013.

24

Unlike surface water depletions to groundwater, the accretionary flow of groundwater to the river is calculated in SACFEM 2013, but the calculation is inaccurate due to the invariant stage height during each monthly time step in the model.

25

SACFEM2013 contains an unusual model construction feature with respect to natural or crop consumptive use and evapotranspirational loss of water. It utilizes a calculation module in MicroFEM called Drains to simulate evapotranspirational losses and groundwater discharge to land surface outside of a recognized and model surface water course. Drains were set at land surface rather than at root zone depth. This is altogether an unusual construction and one that reduces the quantity of water removed by vegetation as constructed. Additional details on SACFEM2013 model review and issues noted are provided in Attachment C herein.

26

SACFEM2013 is not well calibrated to actual conditions of groundwater elevation near rivers and streams. There is almost no mention of model calibration in the EIS/EIR; those two words appear once at page D-13. There are a number of standard references on numerical groundwater modelling that emphasize the importance of model calibration.^{5,6,7} The lack of documentation in the EIS/EIR of model calibration such as how it was conducted and what the degree of precision achieved to which outcomes, is a significant omission. Through sources cited in the EIS/EIR we were able to locate calibration information for SACFEM.⁸ The peer review cited in the EIS/EIR stated:

27

“Review of the representative and other calibration hydrographs reveals that significant calibration issues exists in areas that rely mostly on surface water. This is mainly due to the issues of SacFEM’s estimation of stream-aquifer interaction. Calibration quality improves in areas that rely mostly on groundwater.”⁹

The model documentation we reviewed demonstrated local errors in predicting groundwater elevation heads that are greater than 65 feet (see Attachment C).¹⁰ Calibration errors of this magnitude signify that the groundwater elevations for the water table would fall below the bottom of the uppermost layer in SACFEM2013; the significance of this is that MicroFEM simulation code only calculates unconfined flow conditions in the uppermost layer of a particular model such as SACFEM2013. When actual

⁵ Reilly, T.E., and Harbaugh, A.W., 2004, Guidelines for evaluating ground-water flow models: U.S. Geological Survey Scientific Investigations Report 2004-5038, 30 p.

⁶ ASTM 2001, D 5981-96 (Reapproved 2002), “Standard Guide for Calibrating a Ground-Water Flow Model Application”. Published November 1996, 6 p.

⁷ ASTM 1994, D 5490-93, “Standard Guide for Comparing Ground-Water Flow Model Simulations to Site-Specific Information” Published January 1994, 7 p.

⁸ WRIME, 2011. Peer review of Sacramento valley Finite Element Groundwater Model (SACFEM2013), October.

⁹ Ibid, p. 16.

¹⁰ Lawson, Peter, 2009. Documentation of the SacFEM Groundwater Flow Model. CH2MHill Technical Memorandum. Prepared for Bob Niblack, California Department of Water Resources, February. This document is relied upon heavily in the peer review document cited for Section 3.3 of the EIS/EIR: WRIME, 2011.

groundwater elevations fall below the bottom of Layer 1 in a number of locations, the model is miscalculating the groundwater flux. This demonstrates that the SACFEM2013 model was improperly constructed as well as poorly calibrated. Due to its lack of calibration to actual groundwater elevation conditions, the predictive outcomes are not reliable as a basis for assessing the locations of impact and the degree of impact to Water Supply, Groundwater Resources, Water Quality, and Terrestrial Resource considerations. Attachment C herein highlights further critique of the SACFEM2013 based on information found in the EIS/EIR as to the model's construction and documentation that the EIS/EIR relies upon in regard to the model's construction and calibration.

27

Neither the quantity of water nor the timing of water's removal from surface water is calculated correctly in SACFEM2013 due to the structural deficiencies identified in our review. One of the essential needs in an EIS/EIR on Groundwater Substitution Measures is accurate estimating of the timing of impacts to the flowing rivers and streams; SACFEM2013 does not provide accurate monthly estimates of when peak streamflow depletions will occur if Groundwater Substitution Measures are imposed in large part because of the hydraulic isolation of the pumping from the rivers configured into the model.

28

Accurately quantifying the changes in groundwater storage and groundwater elevations associated with Groundwater Substitution Measures is foundational to defining the potential impacts and their magnitude, and the metrics for the proposed mitigation measure GW-1.

Qualitative Assessments for Groundwater Resources

In section 3.3.1.3.1 Redding Area Groundwater Basin the discussion of Groundwater Production, Levels and Storage does not quantify the quantity of current groundwater pumping or the basin safe-yield without mining out groundwater in any of the six subbasins recognized in DWR Bulletin 118. There is no identification of what impacts to base flows occur from current groundwater extractions for either current Municipal & Industrial (M&I) or applied irrigation. The EIS/EIR does not quantify those groundwater levels (i.e. drawdowns) associated with existing extractions in order to establish what the acceptable groundwater levels (i.e. drawdowns) associated with Groundwater Substitution Measures in this area might be. This is foundational to establish a basis for the proposed mitigation, GW-1, to avoid impacts to existing groundwater users and to avoid impacts to the seasonal base flows in the Sacramento River reaches in the Redding Area Groundwater Basin and those seasonal base flows of the 7 major tributaries to the Sacramento River within the basin. For example our review of the groundwater elevation contours on Figure 3.3-4 indicate that the Sacramento River are between 420 feet and 400 feet above Mean Sea Level between the Clear Creek join and the crossing of the I-5 freeway over the Sacramento at Anderson, CA; since the stream bottom profile of the Sacramento River is approximately 430 feet to 403 feet over this same reach the Sacramento River was losing water in this reach during the Spring of 2013. In addition our review finds that the Sacramento River streambed elevation is above the groundwater elevations of Spring 2013 depicted on Figure 3.3-4 at Colusa, California and southward to the edge of that figure; this means that the Sacramento River from Colusa, California and southward to perhaps Tyndall Landing, California is not only exfiltrating to groundwater, but it is also not gaining the accretionary flow of groundwater that historically occurred in these river reaches.

29

In Section 3.3.1.3.2 Sacramento Valley Groundwater Basin the discussion of Geology, Hydrogeology and Hydrology notes that it was estimated by the USGS that from 1962 to 2003 that streamflow leakage

30

(also called direct exfiltration) amounted to 19% of total basin recharge and equated to 2,527,000 acre-feet per year (AFY) or 3,490 cubic feet per second of surface-water flow. This quantity of water does not denote the entirety of the streamflow depletion from the basin which is the: denied accretionary groundwater flow to the rivers and streams within the basin. However, it is noted that this USGS estimated leakage-loss that discharges from the rivers and streams to groundwater is accounted in their CVHM model as surface water removed.¹¹

30

The impact from surface water leakage to support the groundwater elevations reviewed in Section 3.3 is not quantified and the available response of groundwater elevations to Groundwater Substitution Measures is not quantifiable as a result. In other words if one of the principal sources to groundwater is surface water leakage and that leakage has already reached its maximum rate then the impact from further groundwater extraction must take into account that removal from storage and upgradient flow must meet the demand from Groundwater Substitution Measures.

It appears that neither quantitative nor qualitative evaluation of inflow or outflow to rivers and streams has been done in the EIS/EIR using empirical groundwater and surface water elevation data. Our requests for the database of groundwater elevations used in the EIS/EIR did not yield the Spring 2013 groundwater elevation data used to generate Figure 3.3-4. Further neither the report nor the data provided to our request reveal groundwater elevation data for 2013 in the southerly portions of the Sacramento Valley beyond the extent of Figure 3.3-4. Comparison of empirical (actual) data to mathematical representations in models is essential to assess whether the models are adequately representing the physics of the real-life system being mathematically modeled. Evaluation of empirical data such as land surface, groundwater elevations, and stream stage heights and rated flow rates, enables assessment of the direction of flux and with more sophisticated tools the probable magnitude of flux.

31

Proposed Mitigation for Potential Effects on Groundwater Resources

The Proposed Mitigation GW-1 for groundwater pressure decreases (a.k.a. groundwater elevations) resulting from Groundwater Substitution Measures, GW-1, will not adequately mitigate the impacts to groundwater users in the Seller's Area. Proposed Mitigation GW-1 is not quantified or quantifiable as to what groundwater pressure decreases will constitute an impact to water users in the Seller's Area.

The groundwater elevations necessary to mitigate streamflow depletions under proposed mitigation, GW-1, as well as the stated impact of lowered groundwater levels for existing groundwater users must be quantifiable or else the proposed mitigation is insufficient to reduce the impacts from Groundwater Substitution Measures. For example in the Spring 2013, the Sacramento River streambed elevations are below groundwater elevations from Red Bluff, California to roughly Princeton, California (i.e. the Sacramento River is gaining flow from accretionary flows of groundwater in this lengthy reach) as depicted on Figure 3.3-4 of the EIS/EIR.

32

¹¹ Faunt, C.C., ed., 2009, Groundwater Availability of the Central Valley Aquifer, California: U.S. Geological Survey Professional Paper 1766, 225 p.

The proposed framework for GW-1 is based upon a draft application for preparing water transfer proposals for 2014 from DWR and U.S. Bureau of Reclamation and with the statement that this will be updated as appropriate.¹²

The framework provided for groundwater monitoring and the subsequent proposed mitigation in the EIS/EIR provides no substantive criteria for either monitoring or mitigation. With regard to groundwater monitoring for example at page 3.3-88 under Section 3.3.4.1.2 it states

“The monitoring program will incorporate a sufficient number of monitoring wells to accurately characterize groundwater levels and response in the area before, during, and after transfer pumping takes place.”

There is no attempt at defining the minimum number of wells, a spatial resolution laterally or vertically, nor a timeframe. The subsequent subsection on groundwater level measurement requires measurement of groundwater elevations until March of the year following the transfer; this would imply that impacts from one year’s transfer are not anticipated to carry over into the following year or it implies that this is the new baseline for the subsequent year’s transfer withdrawal. There is no discussion or mention of a multi-year monitoring program in the EIS/EIR with year over year metrics nor are in the draft application guidance for groundwater transfer proposals. A typical application of such a monitoring program using best available science and practice is to establish groundwater elevations in a base year and then metric changes as relative drawdown; in this manner groundwater depletion within a basin or subbasin can be assessed if it is occurring and this would encompass protections against injurious harm to Groundwater Resources if natural recharge is less than normal or slower than one seasonal cycle in providing recovery of the depletion from Groundwater Substitution Measures coupled with other groundwater uses or fluxes. With regard to proposed mitigation for example at Section 3.3.4.1.3, the EIS/EIR states:

“If the seller’s monitoring efforts indicate that the operation of wells for groundwater substitution pumping are causing substantial adverse impacts, the seller will be responsible for mitigating any significant environmental impacts that occur.”

There is no definition provided of what constitutes a substantial adverse impact. Looking back to Section 3.3.2.2 Significance Criteria one finds:

“A net reduction in groundwater levels that would result in adverse environmental effects or effects to non-transferring parties”

There is no benchmark criterion for mitigation and in fact the EIS/EIR at page 3.3-90 then states:

“To ensure that mitigation plans will be feasible, effective, and tailored to local conditions, the plan must include the following elements:

- *A procedure for the seller to receive reports of purported environmental or effects to non-transferring parties;*
- *A procedure for investigating any reported effect;*
- *Development of mitigation options, in cooperation with the affected parties, for legitimate significant effects; and*

¹² Department of Water Resources and Bureau of Reclamation, 2013. DRAFT Technical Information for Preparing Water Transfer Proposals – Information to Parties Interested in Making Water Available for Water Transfers in 2014, October

- *Assurances that adequate financial resources are available to cover reasonably anticipated mitigation needs.”*

This text is extremely unclear as to: technically what is the procedure for investigation of effects; what is the meaning of “legitimate significant effects” when a multitude of overlapping influences on groundwater will occur from natural to man-made; and who would be monitoring and reporting on adverse environmental effects if not the Seller’s and if so then who would be compensating for that monitoring. Our review finds the GW-1 does not provide adequate mitigation for groundwater decreases in the Seller Service Area as it relies upon poorly defined future actions with no established, reliable, or predictable basis for the monitoring and mitigation.

33

Potential Impact Statements from Table ES-4	Related Alternative(s)	Significance to CEQA	Proposed Mitigation	Significance After Mitigation Pursuant to CEQA
Groundwater substitution transfers could cause subsidence in the Seller Service Area.	2, 3	S	GW-1: Mitigation and Monitoring Plans	LTS

When long-term pumping lowers ground-water levels and raises stresses on the aquitards beyond the preconsolidation-stress thresholds, the aquitards compact and the land surface subsides permanently.

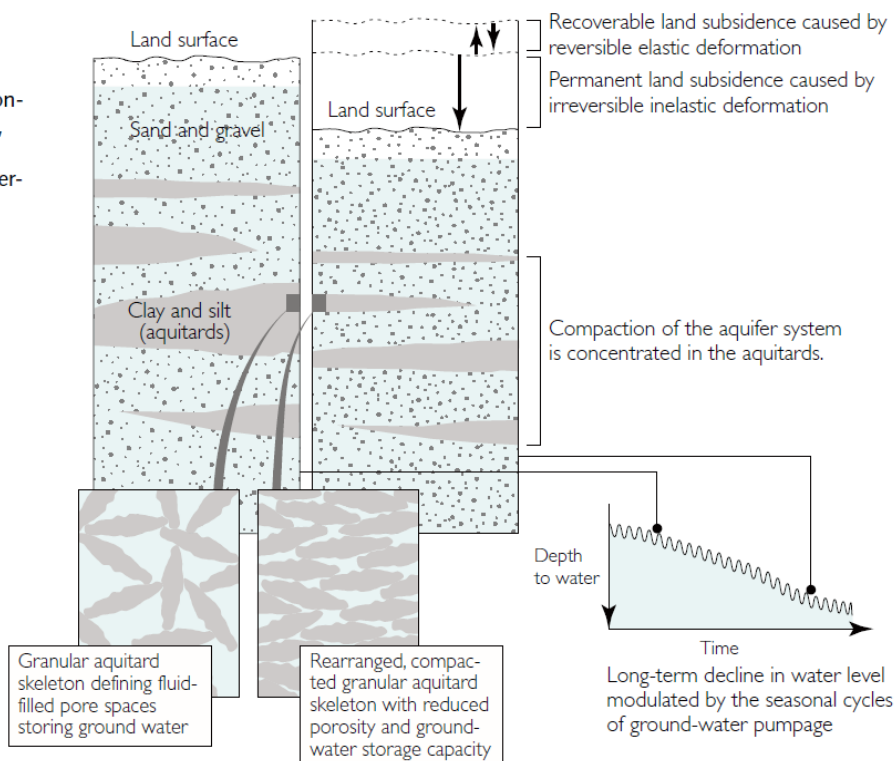

Figure 2 The mechanics of land subsidence due to changes in groundwater elevations, USGS Circular 1182

The groundwater formation in the Seller Service Area west of the Sacramento River is composed of the Tehama Formation.¹³ The Tehama Formation has exhibited subsidence in Yolo County. According to the EIS/EIR similar formational and hydrogeologic characteristics exist in the Redding Area Groundwater Basin.

Groundwater elevation changes due to long term pumping can increase the effective stress on subsurface materials that are under-consolidated. This is typical of some aquitards whose skeletal materials are typically composed of fine-grained sediments and when deposited by lower-energy hydraulic processes their ionic mineral boundaries keep them under-consolidated. When the effective stress of the soil column on these aquitards is increased due to dehydration of the aquifers above them, their skeletons compact. This is known as inelastic subsidence and it causes both a permanent loss of groundwater aquifer storage capacity and a depression at the land surface (Figure 2).

The groundwater elevations depicted on Figures 3.3-8 and 3.3-9 demonstrate that groundwater elevations in three of the eleven wells selected are at historic lows and under existing hydrogeologic and hydrologic conditions are on decadal declining trends. Specifically wells 11N05E32R001M, 21N03W33A004M, and 15N03W01N001M are all at historic lows at their last measurement discounting for seasonality. Each of these wells is in the western half of the Sacramento Valley Basin and thus would be expected to be overlying the Tehama Formation with its known under-consolidated units. Further groundwater extraction by Groundwater Substitution Measures will further lower groundwater elevations in both the Redding Area Groundwater Basin and the Sacramento Valley Basin. The assessment of changes in groundwater elevations reported at Table 3.3-5 is based on SACFEM2013 modeling and is incorrect due to the deficiencies and built-in errors noted for SACFEM2013 to accurately represent cumulative drawdown from Groundwater Substitution Measures. Moreover without specific well depth information and screened intervals for the handful of monitoring wells noted it is impossible in our review to assess whether they monitor the groundwater table portions of the aquifers; the unit where desaturation occurs and effective stresses that induce permanent land subsidence generally occur.

34

Proposed Mitigation

The mitigation proposed for the potential impacts of land subsidence due to decreases in groundwater saturation of the uppermost aquifer, GW-1, is inadequate. The monitoring measures for land subsidence in the EIS/EIR are stated at page 3.3-89 as:

“Subsidence monitoring will include determination of land surface elevation in strategic (determined by Reclamation) locations throughout the transfer area at the beginning and end of each transfer year. If the land surface elevation survey indicates an elevation decrease, then the area will require more extensive monitoring...”

Under this monitoring program approach, permanent inelastic subsidence will have occurred prior to detection. Mitigation is offered in the form of reimbursement for infrastructure (e.g. roadway) structural damage due to permanent subsidence (albeit elastic reversible subsidence would likely also cause infrastructural damage). No mitigation is offered for the permanent loss of aquifer storage capacity.

35

¹³ US Bureau of Reclamation, 2014. “Long-Term Water Transfers Environmental Impact Statement/Environmental Impact Report Public Draft, September, at p. 3.3-17.

Under this program of monitoring and mitigation it has to be noted at Section 3.3.5 Potentially Significant Unavoidable Impacts that this permanent impact of lost aquifer storage capacity is not mitigated by GW-1. Under Sections 3.3.6.1 and 3.3.6.2 for Cumulative Effects for Alternatives 2 and 3, respectively, which include Groundwater Substitution Measures the cumulative effects noted for land subsidence are stated as:

“The groundwater substitution pumping associated with the SWP transfers would occur in an area that is historically not subject to significant land subsidence. In the overall area of analysis, land subsidence is occurring in several areas, as described in Section 3.3.1.3.2.”

The statement is inaccurate. The juxtaposition of Seller locations next to historic subsidence in Yolo County makes the statement inaccurate. The EIS/EIR then goes on to say:

“...however, the existing subsidence along with future increases in groundwater pumping in the cumulative condition could cause potentially significant cumulative effects. The impacts of the Proposed Action would be reduced through Mitigation Measure GW-1 (Section 3.3.4.1) to less than significant. Therefore, with implementation of Mitigation Measure GW-1, the Proposed Action’s incremental contribution to subsidence impacts would not be cumulatively considerable.”

The analysis of changes to groundwater elevations leading to this statement is inaccurate and hence the impacts anticipated are underestimated. Perhaps more to the point the Mitigation Measure, GW-1, as defined will not adequately address the impacts of groundwater drawdown on inelastic subsidence and the resulting permanent loss of aquifer storage in the Seller’s Area. The proposed observation of subsidence as mitigation cannot restore or offset the impact of subsidence once it has already occurred.

It is however possible to define a monitoring and mitigation program for the risks and potential impacts of permanent Land Subsidence. Such a program of monitoring and mitigation would require evaluation of historic and current groundwater elevations in the upper groundwater aquifer units over a series of decades long cyclical hydrologic and land use conditions in each Seller Area to determine whether groundwater elevations are at historic lows. If so then mitigation for permanent land subsidence due to Groundwater Substitution Measures would require no Groundwater Substitution Measures for Long Term Water Transfers be approved until groundwater elevations increase above historic lows and within a range that accurate groundwater modeling could demonstrate would not create cumulative lowering of groundwater elevations during the period of approved water transfers.

Water Supply

At Section 3.1.2 on Environmental Consequences/Environmental Impacts on Water Supply the Assessment Methods states:

“Impacts to surface water supplies are analyzed by comparing the conditions in water bodies and surface supplies without implementing transfers to the expected conditions of supplies with implementation”

The quantitative tool to be used in assessing impacts to supplies but not water bodies from water transfers and exports from the Delta is referred to in the EIS/EIR as a “post-processing tool.” The “post-processing tool” referred to under evaluations of Water Supply for Water Operations Assessment consists of the use of the SACFEM2013 groundwater model, CalSim II, and a spreadsheet model called

the Transfer Operations Model (TOM). Our review will focus on these assessment tools to evaluate potential environmental impacts and consequences from the proposed Long-Term Water Transfers Alternatives.

Section 3.1.2.2 Significance Criteria states:

“Impacts on surface water supplies would be considered potentially significant if the long term transfers would:

- *Result in substantial long-term adverse effects to water supply for beneficial uses”*

Putting aside the substantive issue of why short-term adverse effects to water supply for beneficial uses is not considered as a criterion, our review finds the evaluation in the EIS/EIR of impacts to Water Supply from Groundwater Substitution Measures to this criterion is either inaccurate or insufficient to evaluate the potential environmental impacts associated with Groundwater Substitution as the methods of Assessment in the EIS/EIR do not properly account water and as a result cannot be relied upon to assess potential impacts and the means of mitigation or the timing of mitigation needs. Analysis of streamflow depletions due to Groundwater Substitution Measures is not analyzed accurately in the EIS/EIR and the loss of surface water to meet Water Supply needs is not properly accounted. This inaccurate accounting results in a fraction of the groundwater extracted being double counted as available surface water for transfer.

No Action Alternative Evaluations in EIS/EIR

It is notable that the No Action Alternative is to look at the Environmental Consequences/Environmental Impacts in water bodies (presumably rivers and reservoirs) and surface supplies while the evaluation for implementing Long-Term Water Transfers is to look at surface supplies with no mention of evaluating impacts to water bodies such as rivers or reservoirs.

The quantitative tool to be used to aid in assessing impacts to surface water supplies and water bodies is CalSim II for the No Action Alternative.

CalSim II works on a monthly time-step to assess SWP and CVP operations. CalSim II generates flows as a water system operational decision support tool. CalSim II is not a hydraulic model and does not include channel characteristics such as channel roughness or cross-section geometry to simulate the water routing. As a result of CalSim II’s limitations, the models inability to schedule reservoir releases on a daily basis creates water accounting inaccuracies of losses caused by routing and attenuation of upstream reservoir releases to phenomena such as streamflow depletions. Additionally, CalSim II uses simplified flow routing rules (on a monthly time-step) which result in inaccuracies associated with how the SWP and CVP operate in extreme hydrologic conditions, especially in the driest years (DWR and USBOR, 2004 & Ford et al., 2006).^{14,15}

¹⁴ Department of Water Resources and U.S. Bureau of Reclamation (DWR and USBOR, 2004). Peer Review Response: A Report by DWR/Reclamation in Reply to the Peer Review of the CalSim-II Model Sponsored by the CALFED Science Program in December 2003, August, 2004

¹⁵ Ford, D., Grober, L., Harmon, T., Lund, J.(Chair), McKinney, D. (Ford et al., 2006). Review Panel Report San Joaquin River Valley CalSim II Model Review. CALFED Science Program – California Water and Environment Modeling Forum. January 12, 2006.

CalSim II was developed over a decade ago to assess new storage and conveyance facilities in the CVP & SWP systems on a monthly time-step. Use of CalSim II has yielded significant scrutiny on its ability to provide relevant data to assess potential future impacts (Close, A. et al, 2003).¹⁶ The CalSim II model presented in the EIS was used for the baseline conditions (2014 planning horizon) and was not used to assess potential changes resulting in future land use and hydrologic/metrological conditions. The baseline assessment can only assess how the Long-Term Transfer Project would impact the environment if it was in-place from 1970-2003 and therefore cannot assess potential impacts of future conditions that are different than the baseline conditions such as various climate change scenarios.

37

Alternative 2 and 3 Evaluations in EIS/EIR

The EIS/EIR reaches the following conclusion with regard to Potential Impacts to Water Supply from Groundwater Substitution Measures.

Potential Impact Statements from Table ES-4	Related Alternative(s)	Significance to CEQA	Proposed Mitigation	Significance After Mitigation Pursuant to CEQA
Groundwater substitution transfers could decrease flows in surface water bodies following a transfer while groundwater basins recharge, which could decrease pumping at Jones and Banks Pumping Plants and/or require additional water releases from upstream CVP reservoirs.	2, 3	S	WS-1: Streamflow Depletion Factor	LTS

The analysis of Environmental Consequences/Environmental Impacts is not done accurately nor with a complete conceptual model of the interactive groundwater and surface water system that constitute the Water Supply. At page 3.1.5 in Section 3.1.2.4.1 the analysis states that groundwater basins are naturally recharged after drawdown by rainfall and surface water to groundwater flux, thereby depleting available in stream flow. It goes on to state that the accretionary flow of groundwater to surface water can be intercepted by groundwater extraction; however, it fails to note that this is a depletion of available surface water and water for other beneficial uses such as the health of the riparian and hyporheic zones. As detailed further in our review that follows a proper conceptual model of the hydrologic system for Water Supply demonstrates that the water deprived for the natural consumptive use, evapotranspiration and potentially evaporation via Groundwater Substitution Measures is the likely conserved-water available. The analysis of Water Supply is improperly conceptualized.

38

Additionally at page 3.1.6 in Section 3.1.2.4.1 the EIS/EIR states:

“Transfers would not affect whether the water flow and quality standards are met... but only Reclamation and DWR water supplies”

¹⁶ Close, A., Haneman, W.M., Labadie, J.W., Loucks D.P. (Chair), Lund, J.R., McKinney, D.C., and Stedinger, J.R. (Close, A. et al.). Strategic Review of CALSIM II and its Use for Water Planning, Management, and Operations in Central California. Submitted to the California Bay Delta Authority Science Program Association of Bay Governments. Oakland, California. December 4, 2003.

The EIS/EIR notes that it is the State and Federal projects responsibility to maintain water quality standards in the Sacramento River, its tributaries, and the Delta. It then anticipates hypothetically that if the streamflow depletion resulting from Groundwater Substitution Measures results in decreased river flows then USBOR and DWR would modify operations by decreasing Delta exports or release of additional water from reservoirs to meet Delta outflow and/or water quality standards; however as documented in Attachment D herein the Federal and State projects were unable to maintain these standards in 2013 due to dry year conditions and a lack of available in-stream flow and releases of water.

38

The quantitative tool used in assessing impacts to supplies but not water bodies from water transfers and exports from the Delta is referred to in the EIS/EIR as a post-processing tool. From Appendix B,

“The post-processing tool also includes changes in flows in waterways caused by streamflow depletion from groundwater substitution. Data for the post-processing tool was provided by the SACFEM2013 model, which includes highly variable hydrology (from very wet periods to very dry periods) was used as a basis for simulating groundwater substitution pumping.”

39

The EIS/EIR used two other models, CalSim II and a spreadsheet accounting model referred to as TOM, to attempt to properly account streamflow depletions. A general technical reference from the U.S. Geological Survey (USGS) published in 1998 entitled Ground Water and Surface Water - A Single Resource identifies that the hydrologic cycle demonstrates that groundwater is not a source of water but rather behaves as a reservoir, receiving and releasing water as governed by local and regional hydrologic and hydrogeologic conditions.¹⁷ The use of the combination of three models does not properly account for water and thus the evaluation of “*how long-term transfers could benefit or adversely affect water supplies*” does not accurately identify potential impacts to available-water for Water Supply.

¹⁷ Winter, T.C., J.W. Harvey, O.L. Franke, and W.M. Alley 1998. Ground Water and Surface Water A Single Resource, USGS Circular 1139, pp. 79, p. 2.

Figure 3 depicts the overall hydrologic cycle in Water Supply. The only source of true supply is precipitation in the form of rain, snow, or dew. Groundwater is not a source but an interactive reservoir.

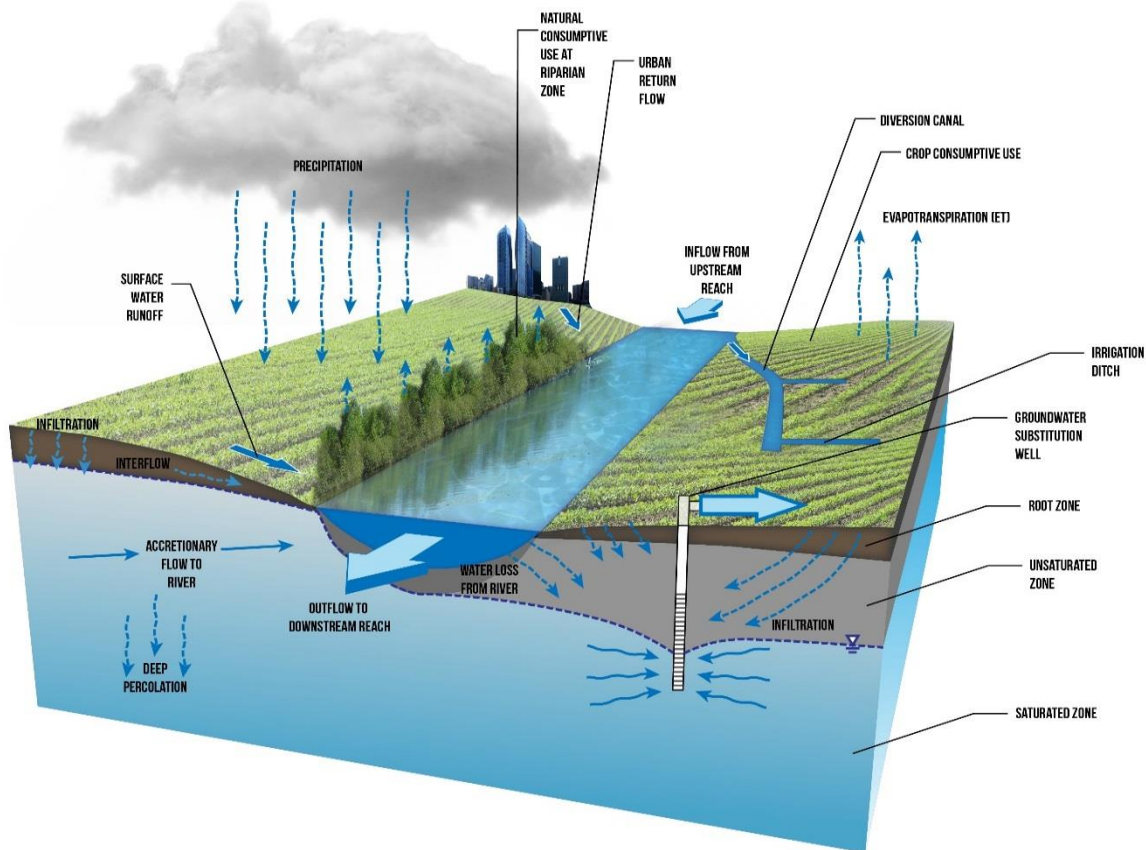

39

Figure 3 Hydrologic Cycle Overview with regard to Water Supply Evaluation

For groundwater in the wells near enough to a river to have the cone of depression reach the river within the hydraulic capture zone of the well the following statement applies:

“When pumping of a well near a river begins, water is drawn, at first, from the water table in the immediate neighborhood of the well. As the zone of influence widens, however, it begins to draw a part of its flow from the river and, ultimately, the river supplies the entire flow”

- Robert Glover and Glenn Balmer¹⁸

This clear statement on the depletion of a river flow by the same rate as that withdrawn from the well is the opening of Glover and Balmer’s 1954 paper on their mathematical analysis of river depletion by extraction from a nearby well. Glover and Balmer’s work followed upon the first analysis of the

¹⁸ Glover, R.E. and G.G Balmer. (1954). River depletion resulting from pumping a well near a river. *Transactions, American Geophysical Union*, v. 35

depletion of streamflow induced by an extraction well and its zone of capture done by C.V. Theis of the USGS in 1941.¹⁹

Dr. Theis commented in his 1941 paper on one aspect of the analysis of the overall effects of extraction in an alluvial river valley on the flow into and from a river:

"...the flux 'from the river' will be spoken of in the following treatment, the flux may be either an actual movement of water from the river or a decrease of the customary movement of water to the river"

- C.V. Theis

This customary movement of water is also commonly known as the accretionary flow of groundwater to the river; it is accretionary flow of groundwater to a river that provides the observable and measurable flow of water in a free-flowing stream during lengthy dry periods when no rain or snowmelt provides the baseflow in a river or stream (i.e. not an ephemeral stream or arroyo). In the illustration below (Figure 4) it can be seen that consistent with Dr. Theis observation on the flux "from the river" the impact to the river is due to loss of accretionary flow to the river and not as a result of direct streamflow

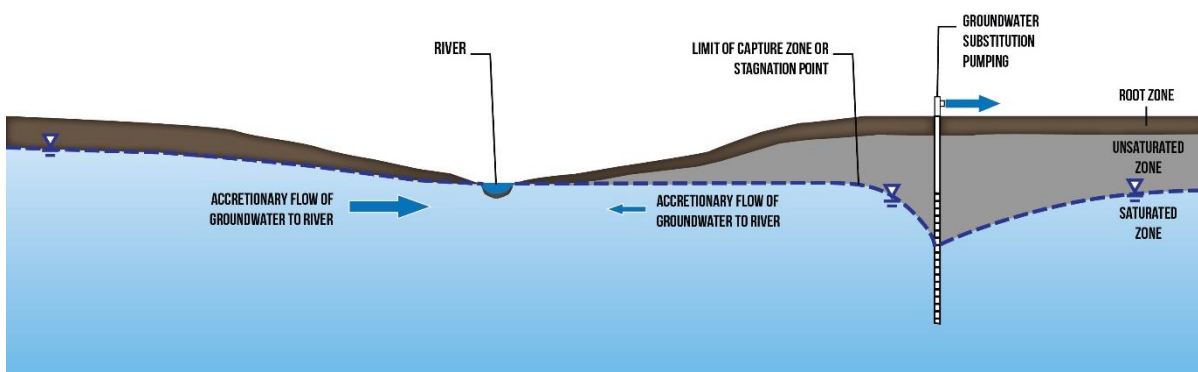

Figure 4 Cross-Sectional View of Extraction Well Depleting the Accretion of Flow to a River

depletion by way of river exfiltration. This phenomena from a well located some distance from the river results in streamflow depletion; the principal difference between this case and the one where the zone of capture to the well reaches the streambed of the river is the timing of the streamflow depletion.

L.K. Wenzel of the USGS in the peer-reviewed Discussion of this seminal paper by Dr. Theis from 1941 offered this observation:

"It is possible that in some localities all or a part of the water removed from the well may be obtained indirectly by reducing the amount of water that is transpired by plants from the zone of saturation. This is accomplished, of course, through the lowering of the water-table and capillary fringe to some depth below the roots of the plants."

- L.K. Wenzel²⁰

¹⁹ Theis, C.V., 1941, The effect of a well on the flow of a nearby stream: *Transactions, American Geophysical Union*, v. 22, part 3, p. 734-737.

²⁰ Wenzel, L.K., 1941, Discussion re: The effect of a well on the flow of a nearby stream: *Transactions, American Geophysical Union*, v. 22, part 3, p. 737-738.

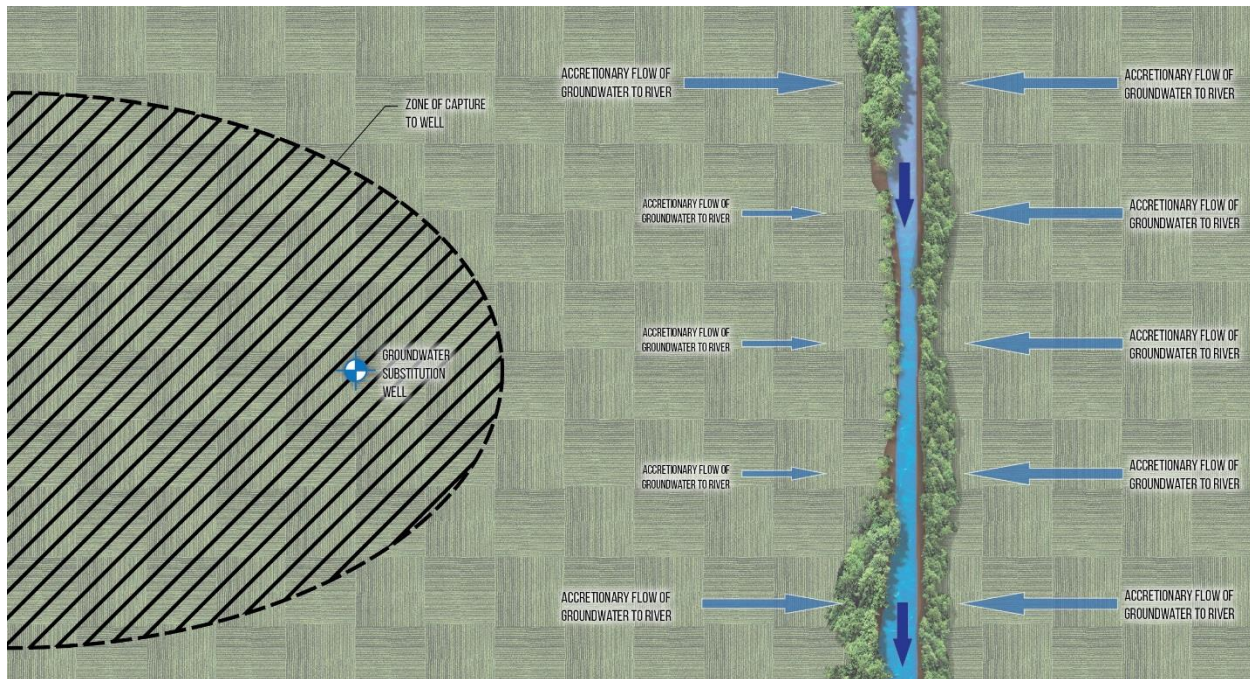

Figure 5 Plan View of Extraction of Groundwater via a Groundwater Substitution Well from which the Zone of Capture to the Well Does not reach the River

Figure 5 illustrates that extraction pumping far back from a river's edge (e.g. perhaps more than 1-mile) does not capture water directly from the river but instead results in a loss of accretionary flow of groundwater to the river as depicted by the reduced accretionary flow arrows and the diminished riparian zone flora (and in all likelihood impacts the hyporheic fauna near and beneath the riparian zone that supports the food chain for pelagic fish such as salmonids and the habitat for other threatened species). The deprivation of flow to the river from a groundwater extraction well located some distance from the river is ultimately equal to the quantity of extraction; if the flow to the well is drawn from storage then that storage will be replaced eventually by an equivalent quantity of groundwater via direct recharge and indirect groundwater recharge. As Dr. Wenzel's comment notes the only water not deprived to the river or stream is that water that would otherwise have been withdrawn for consumptive use and evapotranspiration by vegetation that is/was able to utilize water from the zone of saturation (i.e. the water table aquifer).

Evaluation of the timing of streamflow depletion due to groundwater extraction wells was made simpler by a further paper by Dr. Theis and his co-author in 1963. The following graphic (Figure 6) describes the timing of impact to a stream or river's quantity of flow based upon two primary criteria, the ratio of the aquifer storage coefficient to the aquifer transmissivity, S/T , and the distance between the extraction well and the river.²¹ The coefficients are as described in the Explanation in the chart with the X-axis denoting the time since pumping began.

²¹ Theis, C.V. and C.S Conover. 1963 "Chart for Determination of the Percentage of Pumped Water being Diverted from a Stream or Drain" *USGS Water Supply Paper 1545-C*. pp. C106-C109.

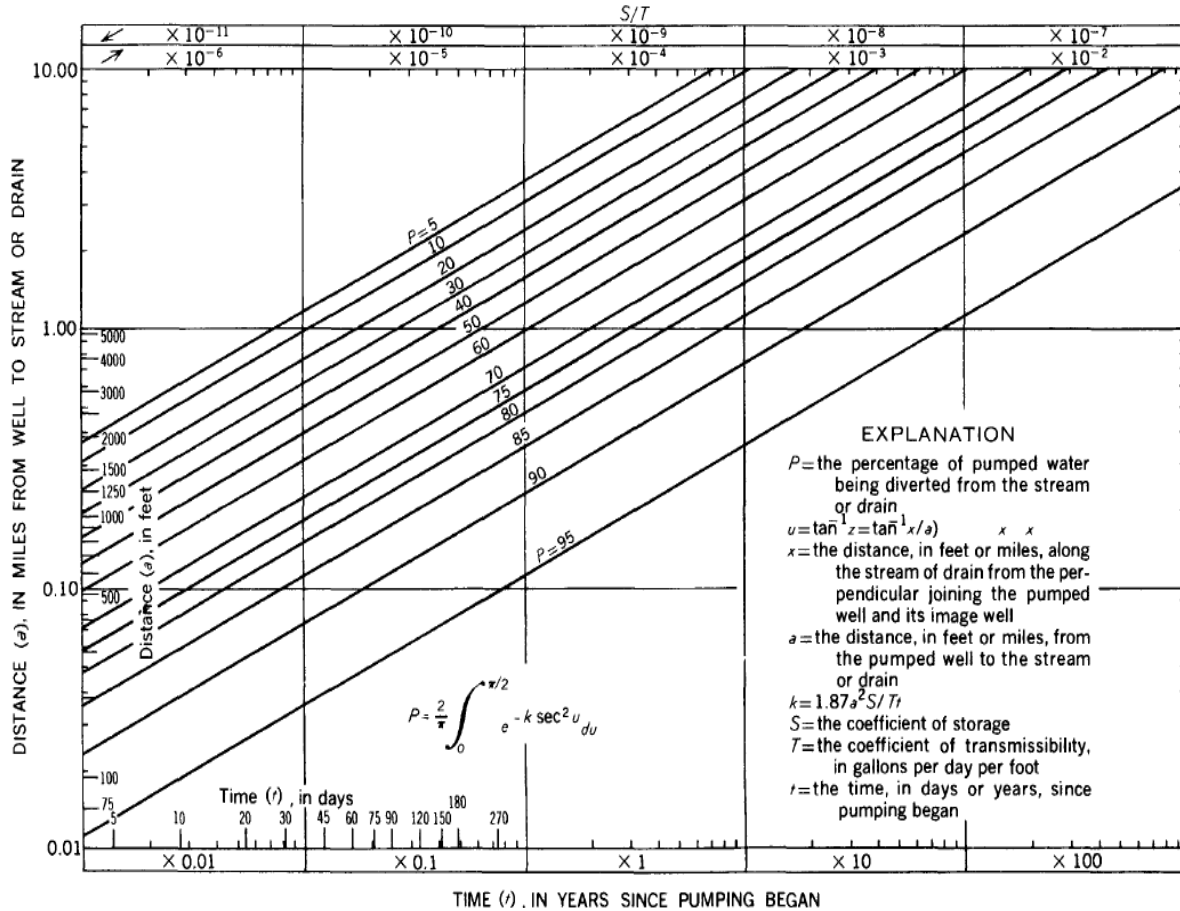

Figure 6 Theis' graphic describing transmissivity and the distance between extraction wells.

FIGURE 30.—Chart for determination of the percentage of pumped water being diverted from a stream or drain.

This method of analysis was then added to by Mahdi Hantush in 1965 by incorporating to the mathematical solution a simplified concept of streambed resistance laterally to groundwater flow by way of a vertical layer of impedance to flow.²²

This group of two general methods was improved upon further by Jenkins in 1968 in several ways but also in describing the residual effects of “streamflow depletion” (a phrase first coined in Jenkins paper) after pumping ceases.²³ Jenkins’ addition to the field of groundwater and surface-water interconnection at river boundaries, enabled season-to-season carryover of depletions of groundwater storage and the resulting streamflow depletion that can take place over more than one annual hydrologic cycle. Wallace et al. (1990) carried out a similar analysis for cyclic pumping of wells.²⁴

²² Hantush, M.S., 1965. Wells near streams with semi-pervious beds. *Journal of Geophysical Research*, v. 70, no. 12: pp2829-2838

²³ Jenkins, C.T., 1968. Techniques for computing rate and volume of stream depletion by wells. *Ground Water*, v. 6, no. 2: pp 37-46.

²⁴ Wallace, R.B., Y. Darama, and M.D. Annable, 1990. Stream Depletion by Cyclic Pumping. *Water Resources Research* v. 26, no. 6, 1263-1270.

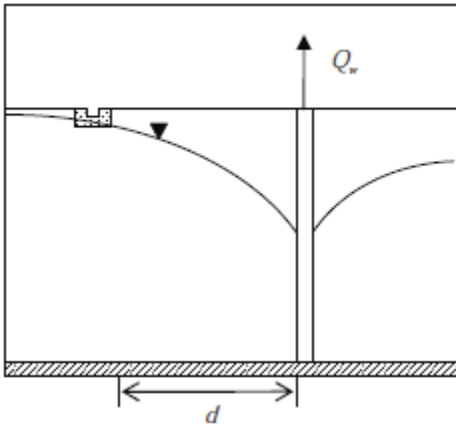

Figure 7 Definition Sketch for a partially penetrating well and a river with semi-pervious layer Hunt (1999)

Subsequently Bruce Hunt (1999) developed an analytical solution to the question of what is the response in a river that has a lower permeability streambed surrounding it than the permeability of the groundwater aquifer to which it is connected including the conceptualization of an extraction well which only partially penetrates the aquifer adjoining the stream.²⁵ While the bounding conditions of a homogeneous aquifer of infinite extent are applied to each of the aforementioned methods in order to solve the equations of unsteady flow in which a well or wells are actively extracting constitute an idealized case, the inclusion of a semi-pervious streambed fully to the solution provides an even more realistic estimate of the timing of impact on flow in a river or stream (Figure 7).

Lastly, Bruce Hunt (2003) developed an analytical solution to the case of a stream incised into a low permeability layer or formation over top of a more permeable aquifer (Figure 8).²⁶

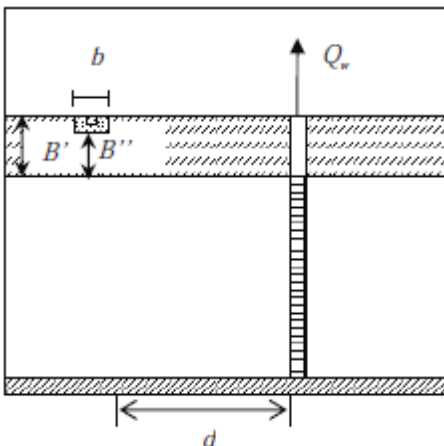

Figure 8 Definition Sketch for flow to well in semipermeable aquifer Hunt (2003)

Each of the four analytical mathematical solutions to the question of the impact of extraction well pumping on flow in a stream and the genesis of the water captured by an extraction well remain valid, particularly where the bounding assumptions are met well by the aquifer being pumped. Various mathematical solvers are available to look at streamflow depletion by the appropriate analytical method for each case including some provide by Dr. Bruce Hunt²⁷; the most recent set of solvers for each of these groundwater to surface-water analytical methods was developed by the USGS (2008).²⁸ The USGS program STRMDEPL08 enables a sequence of time varying pumping during an irrigation season and it allows for year on year carryover of aquifer depletion to be retained in a subsequent year. This program represents “best available science” for near field assessment of groundwater

extraction on the flow in nearby streams. Based upon the information provided in the EIS/EIR with regard to stream aquifer relationships our review determined that the conceptual model of Figure 7, Hunt (1999) best fits the conditions described for the Sacramento Valley. An evaluation of streamflow depletions for select wells near rivers was undertaken for the extended drought period of 1987 to 1992

²⁵ Hunt, B., 1999.. Unsteady stream depletion from ground water pumping. *Ground Water*, 37(1), pp. 98–102.

²⁶ Hunt, B. 2003. Unsteady Stream Depletion when Pumping from Semiconfined Aquifer. *Journal of Hydrologic Engineering*, Vol. 8, No. 1, pp. 12-19.

²⁷ <http://www.civil.canterbury.ac.nz/staff/bhunt.asp>

²⁸ Reeves, H.W., 2008, STRMDEPL08—An extended version of STRMDEPL with additional analytical solutions to calculate streamflow depletion by nearby pumping wells: U.S. Geological Survey Open-File Report 2008–1166, 22 p.

noted in the EIS/EIR was undertaken and the method and results are presented in Attachment A. These analyses result in a range of streamflow depletion factors (SDF) from in short-term SDF ranging from 8% to 22% by the end of a 1987 extraction scenario proffered in the EIS/EIR and long-term cumulative SDF ranging from 34% to 108.5% of annual pumping based on evaluation of the 6-year drought from 1987 to 1992 again following the extraction scenario proffered in the EIS/EIR due to the cumulative depletion of aquifer storage and the available accretionary flow of groundwater to the river as compared to stream flow from the river to satisfy the capture of water by a groundwater extraction well.

39

Assessment of SACFEM2013 Model for Water Supply Analysis in the Post Processing Tool

The SACFEM2013 model in the EIR/EIS does not account for the streamflow depletions induced by groundwater pumping along the lines of any of the analytical methods identified above from the literature. SACFEM2013 has no river flow accounting to account water flow depletions. As for potential impacts to surface water flow rates due to groundwater accretions or depletions SACFEM2013 does not account the quantity of water flowing within a river. There simply is no algorithm in the MicroFEM code to account for changing rates of streamflow and dynamically changing river stage associated with streamflow. Hence these potential impacts are not accounted in the SACFEM2103 model.²⁹ As a result of this missing algorithm in the model the outflow of surface water to groundwater in a river reach where Groundwater Substitution Measures lower the modeled head in the upper aquifer (ignoring the numerous errors in the formulation of well extractions and in the SACFEM2013 model hydraulic parameters)³⁰ below the river bottom water is not properly accounted in SACFEM2013. The loss of surface water flowing into the groundwater domain to satisfy the extraction well demand via streamflow depletion is not accounted. Thus the available Water Supply will not be properly accounted using SACFEM2013 with respect to both the magnitude of the impacts to Water Supply due to Groundwater Substitution pumping and the timing of such impacts to Water Supply and surface water flow in the rivers. This holds for extraction from any of the 327 groundwater extraction wells proposed as a part of Alternatives 2 and 3. This lack of water accounting affects the ability of the “post-processing tool” to properly evaluate water availability under Water Supply due to the shortcomings of the SACFEM2013 model to calculate changes in river flow.

40

Further as to the poor accounting of water available to the “post-processing tool,” the river outflow is not accounted properly in the SACFEM2013 groundwater model at the river nodes. As mentioned under Groundwater Resources SACFEM2013 sets each river reach’s stage height as invariant during a month, irrespective of the groundwater withdrawals. This river stage invariance means that SACFEM2013 calculates as though there is an infinite amount of water in the nearby river (i.e. no streamflow depletion impact on the predicted outflow of water).

41

²⁹ SACFEM2013’s agricultural groundwater extraction terms were reportedly developed using the Irrigation Demand Calculator (IDC) within the California Dept. of Water Resources, Integrated Water Flow Model (simulation code). The use of only a portion of the IWFEM, simulation code and the manner in which it was done leaves the soil moisture model and the groundwater model uncoupled with no feedback between the two models except that perhaps carried by the user from SACFEM back to the IDC model.

³⁰ SACFEM 2013 formulation places all extraction wells into Layers 2, 3, and 4 and then artificially imposes a vertical anisotropy of 500:1 at each flow layer.

The river inflow (i.e. gaining reaches) is calculated in SACFEM2013. However it is done inaccurately due to the invariant stage height during each monthly time step in the model. This imprecision results in an improper accounting of water. Not surprisingly the peer review for the model done in 2011 found:

“Review of the representative and other calibration hydrographs reveals that significant calibration issues exists in areas that rely mostly on surface water. This is mainly due to the issues of SacFEM’s estimation of stream-aquifer interaction. Calibration quality improves in areas that rely mostly on groundwater.”³¹

Using this mathematical formulation in the algorithm for groundwater to surface water flux, the degree of exfiltration in each month from the river to groundwater is too high if flow and stage in the river decrease due to Groundwater Substitution Measures or alternatively the degree of exfiltration is too low if Water Transfer flows increase river stage during the transfer period of July to September as more of that water would be depleted from the stream and not available to the Buyer’s Area. Thus inputs from SACFEM2013 to TOM for subsequent analysis of Water Supply, are inaccurate.

Review of SACFEM2013 by the aforementioned peer review found that SacFEM2013 deep percolation rates are not supported by the fundamental Irrigation Demand Calculation (IDC) module’s methodology (a subcomponent of DWR’s Integrated Water Flow Model, IWFM simulation code) and parameters. This results in a disconnection between SacFEM2013 and IDC. They recommended incorporating a feedback loop between the two models (IDC as constructed for SACFEM2013 input, and SACFEM2013) and subjecting them to convergence criteria. Their review states:

“SACFEM deep percolation rates are not consistent with other data sets and it should be ensured that they are supported by historical land use, crop mix, and agricultural practices.”

It is unknown whether these recommendations from 2011 to SACFEM2013 were incorporated to SACFEM2013 based on the documentation provided in the EIS/EIR and on the documents requested and received from the project proponents. Further review of SACFEM2013 is provided in Attachment C herein.

Lastly with regard to SACFEM2013 and Water Supply considerations we note that unlike Appendix B of the EIS/EIR on the uncertainties and limitations of TOM and CalSim II, there are no statements in Appendix D of the EIS/EIR or the main body of the EIS/EIR as to the uncertainties in the modeling assumptions or stated limitations on the utility and intended uses of the SACFEM2013 groundwater model.

Looking at “Best Available Science” for evaluation of potential impacts in the EIS/EIR there is a simulation code available from DWR, IWFM, which can better evaluate the time varying mass balance between surface water and groundwater inclusive of losses or gains in soil moisture to crop demand and precipitation. The IWFM simulation code’s capabilities are summarized in Attachment B herein and documented for the current release by DWR.³² However, the simulation code with these general capabilities was first publicly released in 2003. Further there is an existing model of the Central Valley in IWFM, C2VSim, which is calibrated for the period 1922 to 2009, which was initially released to the public in 2011. The C2VSim model can be run with either a coarse finite element grid (C2VSim-CG with 1,392

³¹ WRIME. 2011. Peer review of Sacramento valley Finite Element Groundwater Model (SACFEM2013), October at page 16

³² http://baydeltaoffice.water.ca.gov/modeling/hydrology/IWFM/IWFMv4_0/v4_0_331/downloadables/IWFMv4.0.331_TheoreticalDocumentation.pdf.

elements, run-time 6 minutes) or with a fine finite element grid (C2VSim-FG with over 35,000 elements, run-time 6 hours). For both versions, the elements are grouped into 21 water-budget sub-regions.³³ The C2VSim-CG model was utilized in our review to assess the cumulative impacts.³⁴ DWR notes that both C2VSim versions will also be useful tools for integrated regional water management plans, planning studies, groundwater storage investigations, assessing infrastructure improvements, evaluating ecosystem enhancement scenarios, conducting climate change studies, and assessing the impacts of changes to water operations. The results of our assessment of relative streamflow depletions in several river reaches brought about by projected use of available transfer volumes in the extended drought of suggest that streamflow depletions of 8% to 22% depending upon the year and the river reach will result from a mass balanced model. In our review the use of C2VSim-CG provides a reasonable estimate of what best available science would reveal. Use of C2VSim-FG would likely improve upon the accuracy of the estimated streamflow depletions resulting from Groundwater Substitution Measures on Water Supply.

44

Assessment of the CalSim II Model for Water Supply Analysis in the Post Processing Tool

As stated previously for the No Action Alternative, the use of CalSim II has yielded significant scrutiny on its ability to provide relevant data to assess potential future impacts (Close, A. et al, 2003).³⁵ The CalSim II model presented in the EIS was used for the baseline conditions (2014 planning horizon) and was not used to assess potential changes resulting in future land use and hydrologic/metrological conditions. The baseline assessment can only assess how the Long-Term Transfer Project would impact the environment if it was in-place from 1970-2003 and therefore cannot assess potential impacts of future conditions that are different than the baseline conditions such as various climate change scenarios.

45

CalSim II does not provide adequate loss factors to assess potential project impacts. The CalSim II model describes the physical system (e.g., reservoirs, channels, pumping plants), basic operational rules (e.g., flood-control diagrams, channel capacity, evaporation, minimum flows, salinity requirements), and priorities for allocating water to different uses (water quality, ecosystems, etc.). As a result of CalSim II's complexity, very important water loss characteristics such as stream reaches losses, deep groundwater percolation, and stream-aquifer interactions are generalized as basin "efficiencies" rather than losses for specific reaches or stream-aquifer interactions. The lack of specific loss characteristics within CalSim II yields inaccuracies specific to even seasonal and annual water accounting losses (e.g., stream-aquifer interactions) that have been identified as potential impacts from the proposed Long Term Water Transfers.

46

³³ As reported by the DWR at http://baydeltaoffice.water.ca.gov/modeling/hydrology/C2VSim/index_C2VSim.cfm on November 30, 2014

³⁴ Informal telephonic requests to DWR's Bay Delta Office for C2VSim-FG on November 13, 2014 revealed that they view the model as not ready yet for public release.

³⁵ Close, A., Haneman, W.M., Labadie, J.W., Loucks D.P. (Chair), Lund, J.R., McKinney, D.C., and Stedinger, J.R. (Close, A. et al.). Strategic Review of CALSIM II and its Use for Water Planning, Management, and Operations in Central California. Submitted to the California Bay Delta Authority Science Program Association of Bay Governments. Oakland, California. December 4, 2003.

Hydrology modeling within CalSim II uses a “depletion analysis” to estimate the historical and projected level flows (Ford 2006).³⁶ As a result of this, CalSim II requires a calculation to estimate the aggregate stream inflow for each sub-watershed. This calculation is identified as the “closure term” of the hydrologic mass balance and is also how the model encompasses errors resulting from over/under estimates of water losses. In recent documentation regarding future development of CalSim II into version III, DWR and Reclamation provided a graphic of “closure term” magnitudes.³⁷

In this graphic from Draper 2008 (Figure 9), the “closure term” represents a significant amount of error in CalSim that has to be accounted for to create a hydrologic mass balance. Note that this graph is in

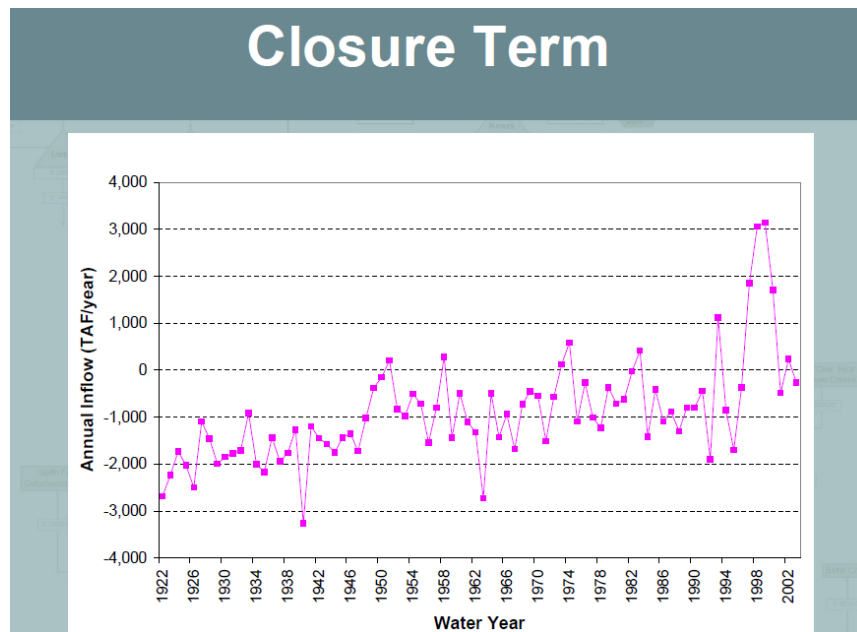

Figure 9 Closure Terms to Correct Accounting Problems in CalSim for Annual Quantities of Water

thousands of acre-feet/year. Thus the “closure term” necessary to correct for water budget errors in CalSim ranges from (2,000,000) AFY in deficit to 3,000,000 AFY in surplus. CalSim II does not account for water on an annual basis with precision.

CalSim II cannot assess how “Long-Term” water transfers would impact future water demands, water supplies, and required water quality and ecosystem management requirements. Hence the analysis of potential impacts to Water Supply based upon CalSim II is insufficient.

CalSim II does not provide adequate detail to assess project impacts. The very poor precision of the surface water delivery model (CalSim II) used for the baseline assessment on quantities of water moving in and around the CVP and SWP leads to problems in accounting for water losses due to existing and proposed groundwater extractions.

As noted in the review of CalSim II in Draper (2008) there is a version of CalSim referred to alternately as CalSim III or CalSim 3 that appears to have been in development and use since approximately 2006.

³⁶ Ford, D., Grober, L., Harmon, T., Lund, J.(Chair), McKinney, D. (Ford et al., 2006). Review Panel Report San Joaquin River Valley CalSim II Model Review. CALFED Science Program – California Water and Environment Modeling Forum. January 12, 2006.

³⁷ Draper, A. CalSim-III Hydrology Development Project, CalSim III Implementation, MWH Americas, California Water and Environmental Modeling Forum Annual Meeting, 2008

“The C2VSim-CG model is being used as the basis for the groundwater flow component of CalSim 3, and has also been used to investigate how Sacramento Valley water transfers may affect Delta flows and how an extended drought may impact groundwater levels.”³⁸

It would appear that CalSim III represents “Best Available Science” with its focus on improving the significant shortcomings in CalSim II identified in our review and that of others. However, CalSim III was not utilized for the EIS/EIR. An analysis of the outcomes for the project by way of CalSim III use would appear to represent something approaching best available science on the available windows of water for transfer prior to 2003 and post 2003 to present and beyond. The availability and uses of CalSim III by USBOR for the CVP could not be determined during our review.

48

Assessment of the Transfer Operations Model for Water Supply Analysis in the Post Processing Tool

TOM was developed to analyze effects of the Long-Term Water Transfer Project on the CVP, SWP, major rivers, and the Delta. TOM does not provide a specialized groundwater, hydrology, or hydraulic simulations of the Long-Term Water Transfer Project but rather provides water accounting based upon inputs from SACFEM2013 and CalSim II. As a result of the water accounting approach, the inaccuracies within CalSim II (e.g., water losses, closure term error, etc.) and SACFEM2013 (e.g., stream-aquifer interactions, groundwater elevation predictions, etc.) are carried over into TOM to quantify and assess potential impacts resulting from the Long-Term Water Transfer Project.

49

Our review of the TOM model provided by the project proponents at our request yielded a number of errors that were also included in the EIS text. Table 1 presents two examples water transfer volumes that were presented in the EIS/EIR Executive Summary Table 2, EIS/EIR descriptive text of each text from section 3.1.1.3, and TOM.

Transfer Description	Table ES-2 (AF)	EIS Section 3.1.1.3 (AF)	TOM (AF)
Anderson-Cottonwood Irrigation District (Maximum Groundwater Substitution Volume)	5,225	5,225	5,938
Garden Highway Mutual Water Company (Maximum Groundwater Substitution Volume)	14,000	12,287	14,000
Conaway Preservation Group (Maximum Cropland Idling or Crop Shifting Volume)	9,239	9,239	21,349

50

Upon review of Table 1, how specific transfer volumes of water are applied in TOM, CalSim II, and SACFEM2013 is neither understood nor constant. Additionally, specific model descriptions of how CalSim II, SACFEM2013 and TOM account for each water transfers are vague. The EIS states that there is a priority of transfer volumes (“...groundwater substitution and reservoir release are more likely transfer mechanisms than crop idling...”, Section B.4.3.1.2) but specifically how each transfer was applied to the

³⁸ As reported by the DWR at http://baydeltaoffice.water.ca.gov/modeling/hydrology/C2VSim/index_C2VSIM.cfm on November 30, 2014

time series and into each model are not documented. To understand how each transfer volume is applied in each model is essential to properly assess the validity of the analysis of potential impacts.

50

Within TOM, adjustments in delivered water through the Delta include a portion lost as carriage water which is defined as extra water needed to carry water across the Delta to export facilities. Carriage water is a critical part of the water modeling analyses because the additional water is needed to maintain Delta water quality. Because the majority of the transfer water is made available and diverted upstream of the Delta, TOM assumes carriage percentage adjustments based on the location of the transfer:

- Transfers from the Sacramento River assume a 20 percent carriage water adjustment;
- Transfers to Contra Costa Water District assume a 20 percent carriage water adjustment;
- Transfers from Merced Irrigation District assume a 10 percent carriage water adjustment for water flowing from the San Joaquin River into the Delta.

51

The use of a single carriage percentage based on location does not adequately address potential impacts to Delta water quality. The concept of carriage water is a complex concept that would require appropriate hydrodynamic models coupled with a hydrology and groundwater model to identify appropriate carriage water volumes over time. The EIS states that the initial estimates for carriage water should later be verified and adjusted and therefore water quality impacts cannot be assessed with the models presented in the EIS/EIR for Long-Term Water Transfers. Additionally, significant stream flow depletion associated with pumping will likely reduce water transfers to the Delta and result in significant water quality impacts and/or limited transfers to water buyers. Therefore, statements with the EIS/EIR claiming limited changes in Delta outflow as well as water quality impacts are unfounded.

Carryover of storage water within reservoirs is one of many factors within the EIS/EIR, TOM and CalSim II that lacks a description of application. In other words there is no detail provided on where each of the water volumes in TOM are derived (e.g. groundwater vs. stored water). As a result of streamflow depletion from Groundwater Substitution Measures, the EIS/EIR identifies that small decreases in water supplies to users could occur when the stored reservoir release transfers decrease carryover storage in reservoirs. These operational controls are very important to how storage facilities would operate during extended dry periods. These operational assumptions within the modeling are not described in the EIS/EIR text or models. Therefore, carryover along with other operational assumptions associated with the Long-Term Water Project is not properly assessed and the resulting operational Water Supply impacts could be significant; these potential and probable impacts to Water Supply are not analyzed in the EIS/EIR for Groundwater Substitution Measures.

52

Summary of Impact Assessment

Impacts to Water Supply from the Water Operations Assessment are not fully quantified. The improper accounting of water under Groundwater Substitution Measures results in insufficient control on water accounting such that water lost from river flow due to both the impairment of accretionary groundwater flow to support Project operations and the direct losses from river flow to groundwater extraction wells in the Groundwater Substitution program may be counted twice or more. Evaluation of the effects on Water Supply from the Groundwater Substitution Measures requires adequate and accurate analysis of what the sources of water in Water Supply and what appropriate streamflow depletions are for

53

Groundwater Substitution Measures on top of existing conditions to assess short-term and long-term effects on Water Supply from Long-Term Water Transfers. Further the use of Groundwater Substitution Measures has important impacts to Water Supply in regard to operational flexibility. These have been rated to be Less Than Significant in the EIS/EIR but given the substantive errors noted in assessing available water for Long-Term Water Transfers this likely deserves re-examination.

53

Proposed Mitigation

Due to the improper accounting of water in Water Supply, the proposed mitigation WS-1 is inadequate to mitigate the likely impacts to water availability and water flows into and through the Delta during three important periods of time: (1) the period of Groundwater Substitution pumping, April thru September; (2) the Water Transfers window, July thru September; and, (3) the period following the Water Transfers window, October to April.

54

The Proposed Mitigation WS-1 to address streamflow depletion resulting from Groundwater Substitution Measures is ill defined and will not adequately mitigate the impacts to Water Supply.

55

Due to the lack of a specific formulation for the proposed Water Supply mitigation, WS-1, it is unpredictable how the mitigation will be applied. The EIS/EIR references Draft documents on Technical Information for Preparing Water Transfer Proposals (October 2013).³⁹ Those documents identify the need for estimating the effects of transfer operations on streamflow and describe the use of a streamflow depletion factor; however they provide no basis for Project Agency approval nor for transfer proponents to submit site-specific technical analysis supporting a streamflow depletion factor. That document which is completely relied upon in establishing proposed mitigation, WS-1, states that:

56

“Project Agencies are developing tools to more accurately evaluate the impacts of groundwater substitution transfers on streamflow. These tools may be implemented in the near future and may include a site-specific analysis that could be applied to each transfer proposal.”⁴⁰

This future action provides no established or predictable basis for the mitigation of streamflow depletions due to Groundwater Substitution Measures. Due to the improper accounting of water in both the groundwater and surface water supply models utilized for Water Supply analysis, reliance upon these models or the analysis in this EIS/EIR by the Project Agencies would result in inappropriate estimation of the streamflow depletion factors utilized. Examples of best available science methodologies for quantifying streamflow depletion factors for Water Supply are provided in Attachment A . They result in short-term streamflow depletion factors ranging from in short-term SDF ranging from 8% to 22% of the Groundwater Substitution Measures proposed in the EIS/EIR and long-term cumulative SDF ranging from 34% to 108.5% of annual pumping based on evaluation of the 6-year drought from 1987 to 1992

57

The mitigation proposed for loss of Water Supply, WS-1, due to Groundwater Substitution transfers is insufficient. It does not adequately account for the impact from the resulting reductions of water available in the rivers and groundwater due to the improper accounting of water in the EIS/EIR analyses.

58

³⁹ Department of Water Resources and Bureau of Reclamation, 2013. DRAFT Technical Information for Preparing Water Transfer Proposals – Information to Parties Interested in Making Water Available for Water Transfers in 2014, October.

⁴⁰ Ibid, at p. 33.

As detailed in our analysis the mitigation measure proposed has no basis in fact, and if it did the project proponents would find that mitigation of the impacts from Groundwater Substitution Measures are not likely to meet the Project Purpose and Need and the Project Objectives.

58

Water Quality

Groundwater Substitution Measures for Long-Term Water Transfers effects on Delta outflows and water quality are not properly considered in the EIR/EIS. The EIS/EIR rates the effects on Delta outflows and the impact to Delta Water Quality as Less Than Significant based on improper accounting of water. The effects and impacts are likely to be Significant and thus will require mitigation.

59

Potential Impact Statements from Table ES-4	Related Alternative(s)	Significance to CEQA	Proposed Mitigation	Significance After Mitigation Pursuant to CEQA
Water transfers could change Delta outflows and could result in water quality impacts.	2, 3, 4	LTS	None	LTS

The analysis of Environmental Consequences/Environmental Impacts is not done accurately nor with a complete conceptual model of the interactive groundwater and surface water system depletions that would affect the Federal and State water projects, CVP and SWP, to meet Water Quality requirements. As noted previously the analysis of components for Water Supply is improperly conceptualized and yet finds that streamflow depletion of significance can occur and must be mitigated by application of an appropriately calculated SDF.

Again from page 3.1.6 in Section 3.1.2.4.1 the EIS/EIR states:

“Transfers would not affect whether the water flow and quality standards are met...” but only Reclamation and DWR water supplies”

60

The EIS/EIR anticipates hypothetically that if the streamflow depletion resulting from Groundwater Substitution Measures results in decreased river flows then USBOR and DWR would modify operations by decreasing Delta exports or release of additional water from reservoirs to meet Delta outflow and/or water quality standards; however as documented in Attachment D herein the Federal and State projects were unable to maintain these standards in 2013 due to dry year conditions and a lack of available in-stream flow and releases of water.

Under Assessment Methods at page 3.2-27 in Section 3.2.2.1.1 states that quantitative analysis relies on hydrologic modeling estimated changes in river flow rates and reservoir storage for the CVP and SWP reservoirs and the rivers they influence. The quantitative analysis is left to Appendix B but the main body states that:

“If the changes are small and within the normal range of fluctuations (similar to the No Action/No Project Alternative) for that time period, it is ... assumed that any water quality impacts would be less than significant”

61

According to the EIS/EIR:

*“CalSim II is the latest version of CalSim available for general use. It represents the Central Valley with a node and link structure to simulate natural and managed flows in rivers and canals. It generates monthly flows showing the effect of land use, potential climate change, and water operations on flows throughout the Central Valley.”*⁴¹

With Closure Terms to rectify storage and flow on the order of millions of acre-feet per year (as much as 3,000,000 AFY during the model periods simulated for the EIS/EIR), CalSim II is not an adequate tool for assessing whether flow and required storage changes under the proposed Groundwater Substitution Measures are small, normal or significant to enable the assumption of insignificant water quality impacts. Further CalSim II works on a coarse monthly time-step to assess SWP and CVP operations. However, water quality and ecosystem management decisions require a more detailed weekly or daily time-steps to properly account for potential water availability and timing impacts. CalSim II is not the appropriate modeling system to assess the Long-Term Transfer Project which will cause daily flow changes that require water quality and ecosystem management decisions to mitigate impacts before they occur and does not represent best available science (see earlier comment on CalSim III under Water Supply).

61

Contracted Reservoir Releases by the Sellers may be diminished by streamflow depletions from current pumping conditions in areas where groundwater saturation falls below the river stage adjoining under existing conditions. These depletions of water available for transfer via Reservoir Releases and are not quantified in the EIS/EIR. The effect of these baseline conditions impacts the availability of water to be transferred down the Sacramento River and through the Sacramento San-Joaquin Rivers Delta to the CVP and SWP pumping stations that pump water south via their respective aqueducts, the Delta-Mendota Canal, and the California Aqueduct.

62

The quantitative analysis of potential Water Quality impacts to the Sacramento-San Joaquin Delta is provided in Appendix C. Appendix C states at page C-2 that:

“The Delta Conditions analysis is performed with the Delta Simulation Model 2 (DSM2). DSM2 setup relies on the output of three additional tools for this Project: CalSim II, the Transfer Operations Model (TOM), and the Delta Island Consumptive Use model (DICU model). CalSim II outputs simulating California’s water delivery system to the Delta are used to supply inflow and export boundary conditions to DSM2.”

63

Use of a CalSim II model with monthly outputs that are crude approximations of actual system performance at best renders use of these outputs to create daily approximations that are supplied to DSM2 useless in assessing the potential for water quality impacts from proposed Groundwater Substitution Measures that will impair the actual timing of surface-water baseflow as a result of streamflow depletion and the quantity of water available to meet Delta Water Quality requirements.

Proposed Mitigation

Our review finds that the Less Than Significant assessment in the EIS/EIR lacks sufficiently accurate analysis as to available flows and storage of water in the Sacramento River watershed by virtue of the precision of the models used in the quantitative assessment. Mitigation is likely required to assure

64

⁴¹ EIS/EIR Public Draft Under Review at page C-5

sufficient baseflow and stored water availability for CVP and SWP operating requirements for Water Quality.

64

Terrestrial Resources

Potential Impact Statements from Table ES-4	Related Alternative(s)	Significance to CEQA	Proposed Mitigation	Significance After Mitigation Pursuant to CEQA
Groundwater substitution could reduce stream flows supporting natural communities in small streams	2, 3	S	GW-1	LTS

Assessment methods in the EIS/EIR for riparian, wetland, and natural in-stream community (e.g. fauna in the hyporheic zone such as Caddis fly larvae) impacts include SACFEM2013. Reportedly SACFEM2013 predicted changes in groundwater elevations over time were used to assess the potential impacts of groundwater depletion on stream flows in small tributaries and associated natural communities. However, it should be noted that in wetland and riparian habitats, groundwater typically ranges from eight feet to just below the ground surface Faunt (2009).⁴² As noted previously under the discussion of Groundwater Resources evaluations, SACFEM2013 contains an unusual model construction feature using model “Drains” with respect to riparian habitats consumptive use of water, its evapotranspiration of water, and groundwater discharge to land surface outside of a recognized and model surface water course. Drains were set at land surface rather than at root zone depth. Thus SACFEM2013 is highly imprecise in its ability to discern where and how much a riparian or riverine habitat is utilizing groundwater or residual soil moisture (see earlier commentary on the decoupling of the soil moisture model from the SACFEM2013 groundwater model)

65

The EIS/EIR notes that:

“...groundwater modeling results indicate that shallow groundwater is typically deeper than 15 feet in most locations under existing conditions, and often substantially deeper...”⁴³

Modeling is not the best available science for this analysis when empirical data are available to assess actual or anticipatable depth to a phreatic surface or the capillary fringe of water rising above the phreatic surface in native sediments and soils. For example groundwater elevations of Spring 2013 depicted on Figure 3.3-4 along the Sacramento River main stem from Red Bluff, California to roughly Princeton, California are above the streambed elevations. This indicates that the Sacramento River is gaining flow from accretionary flows of groundwater in this lengthy reach, and the phreatic surface of groundwater would be expected to be eight feet or less below ground surface along the riparian corridor of the river with possible wetlands. Similarly groundwater elevations depicted on Figure 3.3-4

⁴² Faunt, C.C., ed., 2009, Groundwater Availability of the Central Valley Aquifer, California: U.S. Geological Survey Professional Paper 1766, 225 p

⁴³ EIS/EIR Public Draft at page 3.8-32

along the Feather River from Oroville to Live Oak are above the streambed elevations. Conditions for the riparian corridor and potential wetlands may exist based on these data. The areas where groundwater elevations are below the elevation of the bottom of river courses was noted in the discussion of Groundwater Resources; yet an analysis of near river and stream course depths to groundwater or the capillary fringe can be reasonably estimated from the data. Data are better than models for current or historic conditions analysis.

65

Terrestrial Resource impacts are not properly accounted in the EIS/EIR due in part to the imprecision and inability of the models to assess dehydration of the soils and groundwater aquifer adjoining streams and large rivers.

Proposed Mitigation

Proposed Mitigation GW-1 is not quantified or quantifiable as to what groundwater pressure decreases will constitute an impact to natural communities in and near small streams in the Seller Service Area.

The groundwater elevation changes within a conceptual monitoring plan that would be necessary to mitigate stream flows supporting natural communities in small streams under proposed mitigation, GW-1, must be quantifiable or else the proposed mitigation is insufficient to reduce the impacts from Groundwater Substitution Measures. The proposed mitigation, GW-1, is not sufficiently quantified in the EIS/EIR nor in the Groundwater Management Plans (GWMPs) referenced. Existing GWMPs do not contain quantified year on year metrics for subbasin depletion and refill within acceptable ranges to sustain primary functions like support for natural communities.

66

Potential Impact Statements from Table ES-4	Related Alternative(s)	Significance to CEQA	Proposed Mitigation	Significance After Mitigation Pursuant to CEQA
Transfer actions could alter flows in large rivers, altering habitat availability and suitability associated with these rivers	2, 3, 4	LTS	None	LTS

Much of the discussion of small streams is applicable to large rivers. Additional considerations are noted in the following discussion that demonstrate a finding of Less Than Significant is apparently due to a faulty analysis of the type of impacts, and their foreseeable magnitude and likelihood of creating Significant impact to habitat supported by large rivers.

Water transfers would affect flows in the rivers and creeks adjacent to and downstream of the areas where transfer activities (of all kinds) would occur. Changes in stream flows that would result within the Seller Service Area may affect natural communities, such as riverine, riparian, seasonal wetland, and managed wetland natural communities, which are reliant on CVP and SWP operational outcomes with Water Transfers such as surface-water flow velocity, surface-water quality (in particular water temperature both released and exchanged with groundwater), and the accretion or depletion of

67

groundwater near surface. These operational outcomes and effects could propagate downstream of the areas/locations where pumping occurs.

67

The extraction scenarios proffered in the EIS/EIR will cumulatively over time and space reduce the available accretionary flow of groundwater to the large rivers in addition to the loss of water directly from the adjoining large river, where proximate to a well or wells, to satisfy the capture of water by groundwater extraction wells used for Long-Term Water Transfers as Groundwater Substitution Measures.

68

Releases of storage water within reservoirs is one of many factors within TOM and CalSim II that lack a sufficient description for the analyses required here for natural habitat flow requirements. An adequate form of model would incorporate anticipated timing of natural flow impacts and controlled releases for Water Transfers. Again the best available science would include implementation of the IWFM simulation code to an appropriately configured model. Due to the IWFM codes ability to account stream flows dynamically in the simulation code's algorithms the timing and magnitude of flows could be quantified. From this foundational quantification additional models on river flow velocities, bed scour, temperatures and other attributes of Seasonally Varying Flow (SVF) that has been found to be essential to riverine habitat.⁴⁴ In other words there is no detail provided on where each of the water volumes in TOM are derived (e.g. groundwater vs. stored water). As a result of streamflow depletion from Groundwater Substitution Measures, the EIS identifies that small decreases in water supplies to users could occur when the stored reservoir release transfers decrease carryover storage in reservoirs. These operational controls are very important to how storage facilities would operate during extended dry periods.

69

Proposed Mitigation

A reanalysis of the potential impacts of Water Transfers is required using best available science to ascertain the magnitude of potential impacts, system operational constraints on those impacts, and the method and implementation of mitigation, if needed.

70

Fisheries

The findings of Less Than Significant for Fisheries is not supported by the analytical tools based upon the preceding analyses of Groundwater Resources and Water Supply and should be revisited as to availability of water to support riparian and hyporheic zones along the waterways for habitat support for species of special interest identified in Section 3.7.1.2 and as to timing and quantity impacts of river flows due to streamflow depletions evaluated under Water Supply.

71

⁴⁴ Risley, John, Wallick, J.R., Waite, Ian, and Stonewall, Adam, 2010, Development of an environmental flow framework for the McKenzie River basin, Oregon: U.S. Geological Survey Scientific Investigations Report 2010-5016, 94 p.



ATTACHMENT A
STREAMFLOW DEPLETION CALCULATIONS USING USGS STRMDEPL08
FOR SELECT GROUNDWATER SUBSTITUTION TRANSFER WELLS

Development of Streamflow Depletion Factors for Select Wells

The USGS released in 2008 a numerical code, STRMDEPL08, that solves the analytical solutions of Theis, 1941, Hantush 1954, Hunt 1999, and Hunt 2003 for groundwater interaction with nearby streams. One of the key advantages to STRMDEPL08 is the ability to use time varying flow rates and shorter time steps down to one half of a calendar month.

Six wells in close proximity to streams based upon the input arrays provided for SACFEM2013. The distance to the nearest stream or river was calculated in GIS to the polylines for surface water bodies provided in response to the Delta Water Agency for model input datasets. This was generally found to be a greater distance than represented by the nodal structure of surface water nodes in SACFEM2013 vs. the groundwater extraction well nodes. Hence this is a conservative estimate of configuration with regard to expected streamflow impact (the distance of an extraction well from a stream is a key determinant in the timing and magnitude of the streamflow depletion)

Streambed thickness was set at 1 meter per the model documentation. Stream widths were as provided. Additionally the streambed vertical conductivity was as specified in the SACFEM2013 model dataset. These values were found to range from 1 meter/day to 0.1 meter/day which does not correspond to the Appendix D documentation but was used anyway.

The pumping stress was applied for the extended drought period of 1987 to 1992 for each well. The pumping rate applied for each well was derived from the information provided by the Bureau of Reclamation for their TOM operational analysis model. The total water available for extraction and transfer by the six entities (Sellers) for which a well was evaluated was used. The rate for the well was estimated by dividing the total quantity transferable by the number of wells owned (e.g. Pelger Mutual Water Company). It was then further modified by applying an estimate of Evapotranspiration on the average climatic zone of Yuba City. Groundwater extraction was thereby curved from April to September, the period of water demand for crops in that climate.

The results for 6 wells are depicted on the following pages, first by fraction of annual pumping per month, and then by cumulative extraction by pumping year. The carryover of depletions produces cumulative losses of more than 100% in certain years based upon the annual variability in pumping rates.

CHART A2: ConawayPG Node 12680
 Cumulative Streamflow Depletion as a Percentage of Yearly Pumping

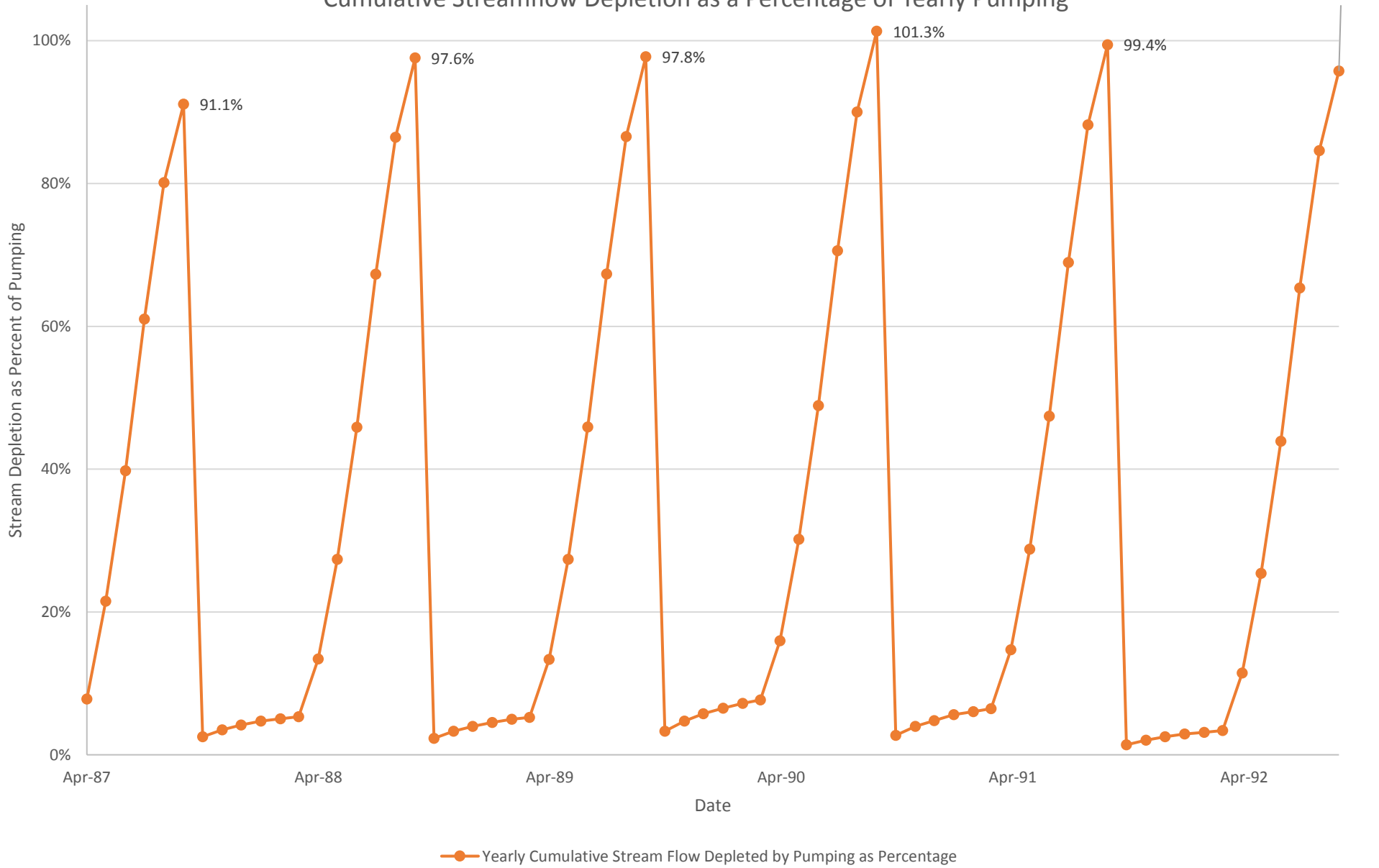

CHART A4: Cranmore Farms Node 86770 Cumulative Streamflow Depletion as a Percentage of Yearly Pumping

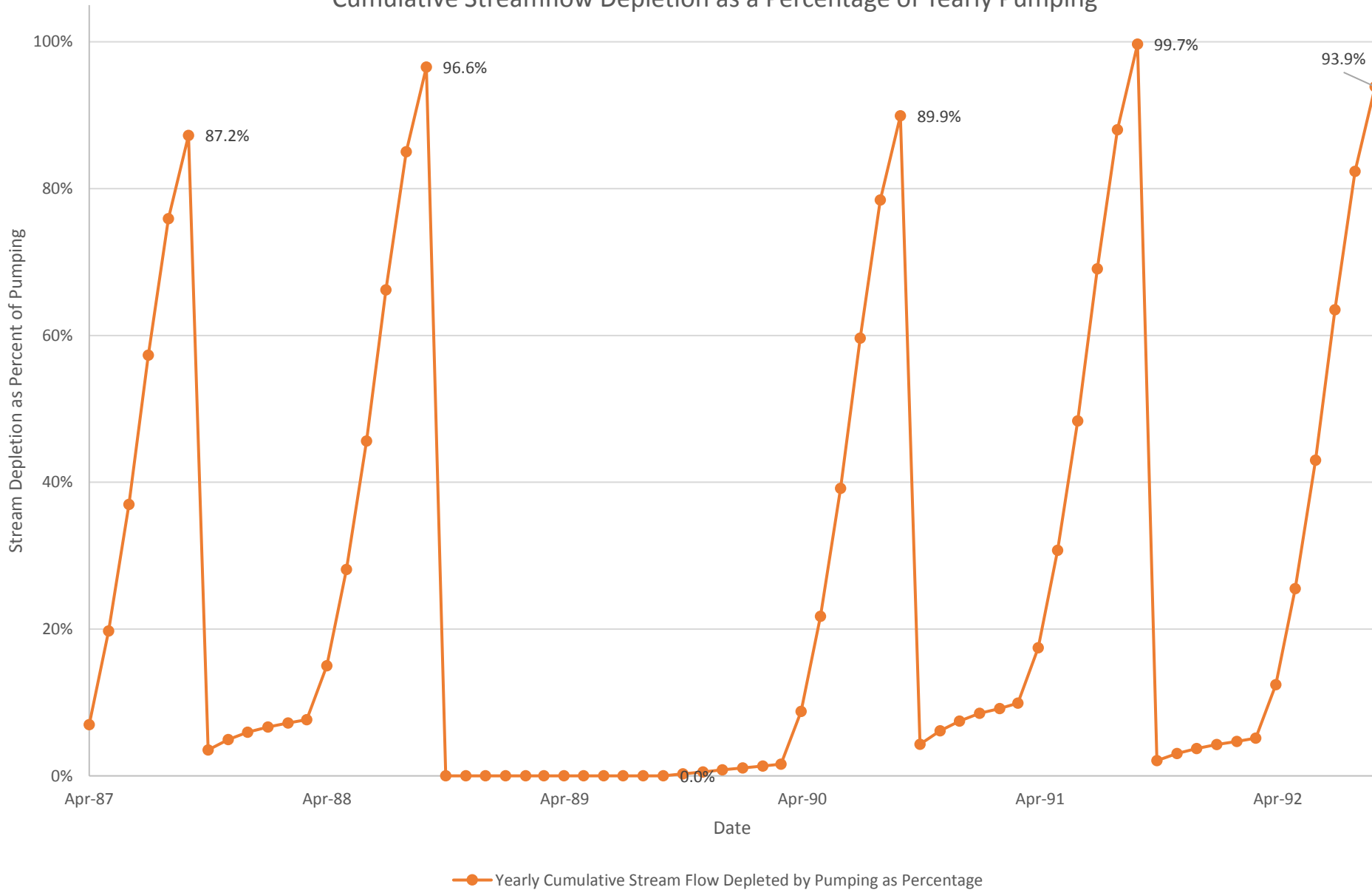

CHART A5: Garden Highway MWC Node 85452
Stream Depletion as Percentage of Pumping

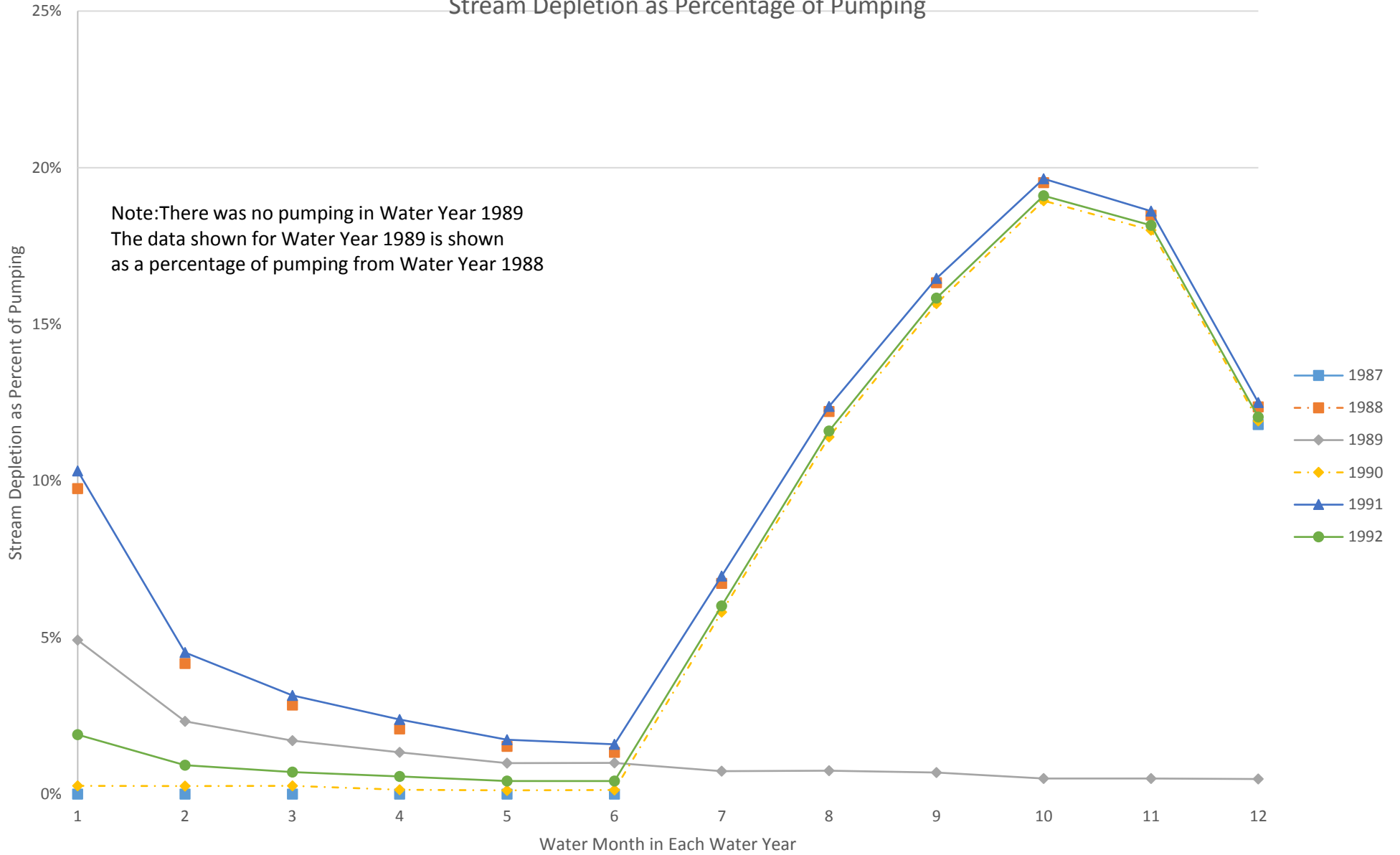

CHART A6: Garden Highway MWC Node 85452
Cumulative Streamflow Depletion as a Percentage of Yearly Pumping

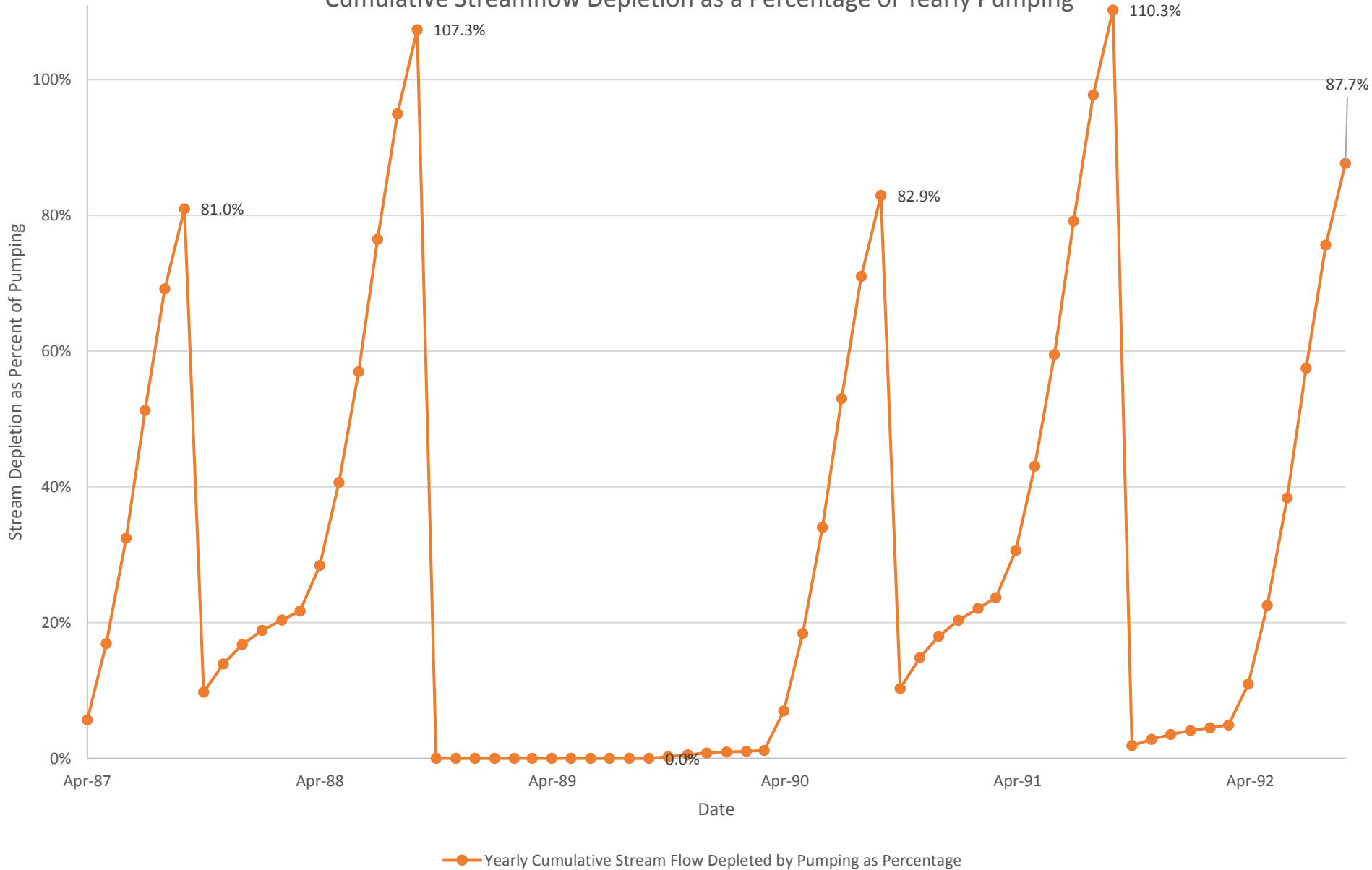

CHART A7: Pelger MWC Node 90539
Stream Depletion as Percentage of Pumping

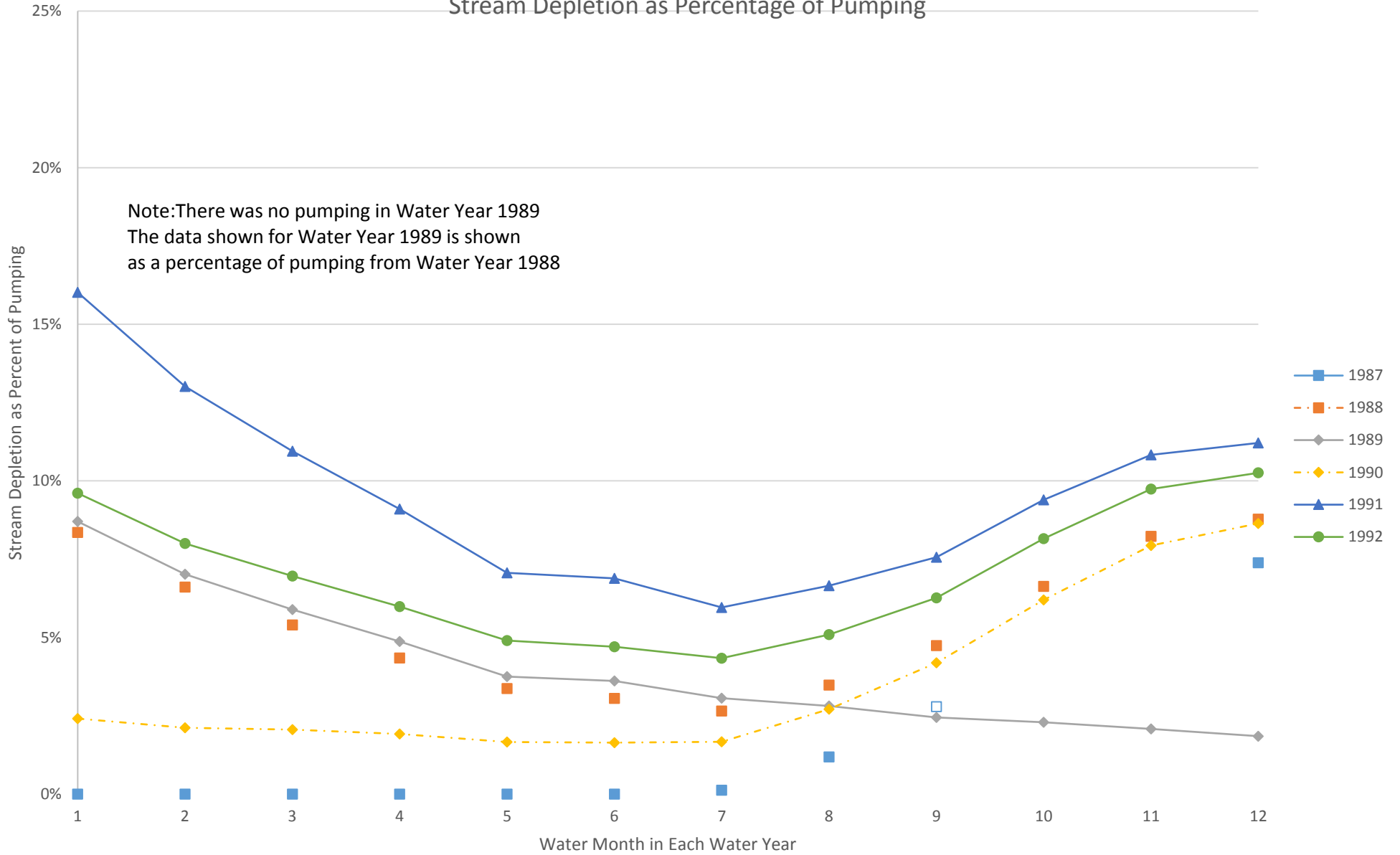

CHART A8: Pelger MWC Node 90539
Cumulative Streamflow Depletion as a Percentage of Yearly Pumping

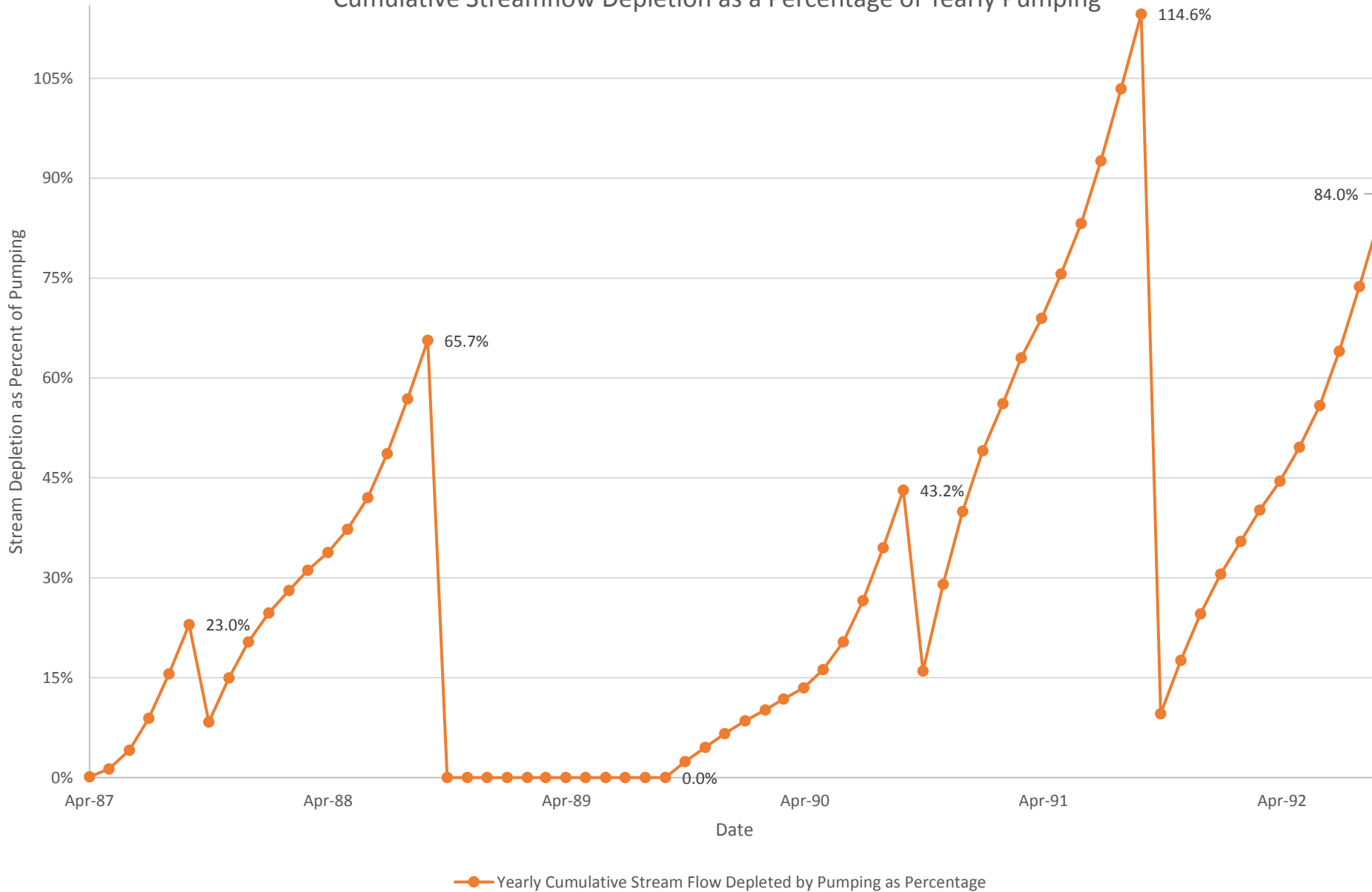

CHART A10: PGVMWC Node 134607
Cumulative Streamflow Depletion as a Percentage of Yearly Pumping

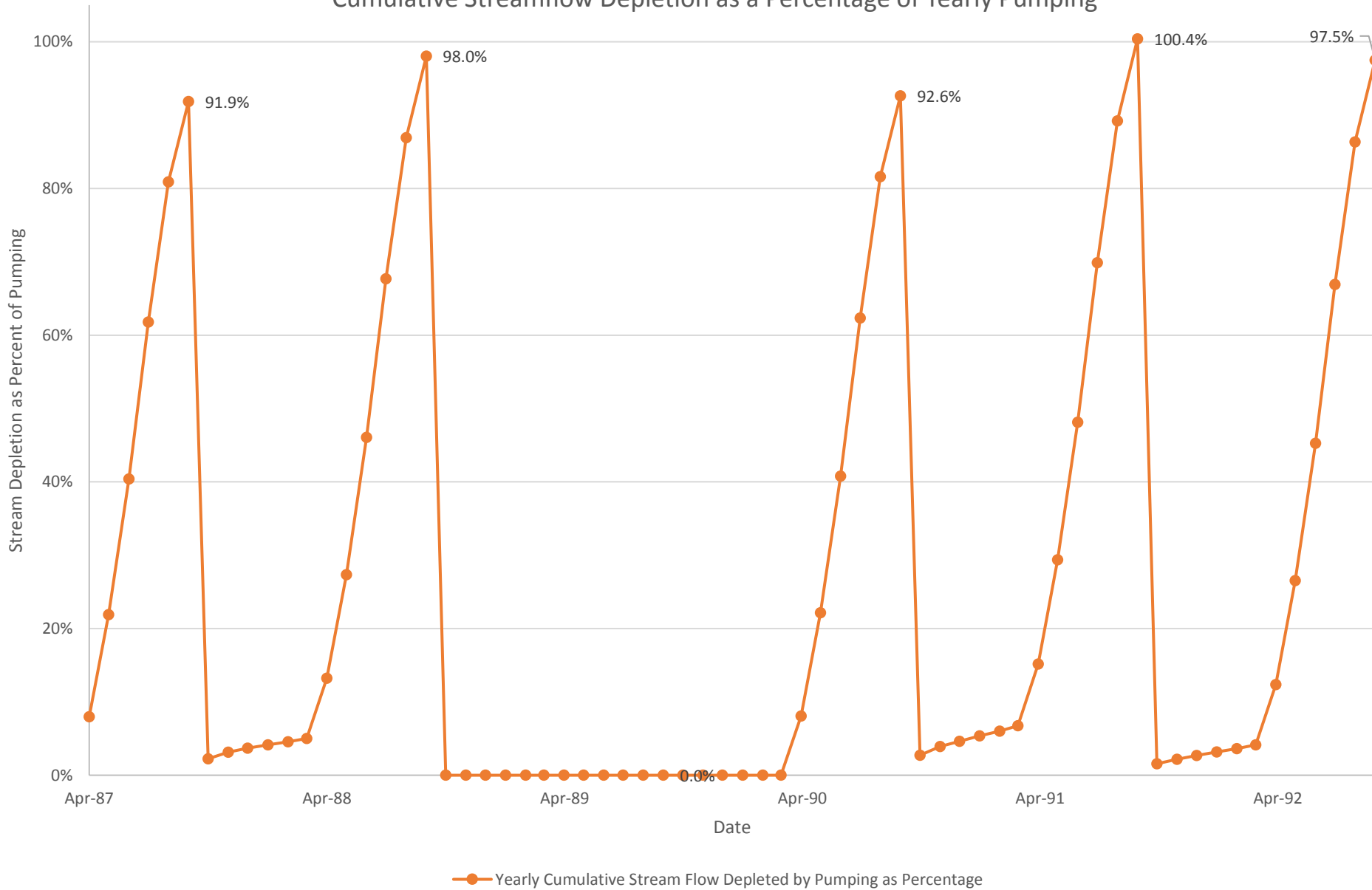

CHART A11: Sycamore Family Trust Node 66434
Stream Depletion as Percentage of Pumping

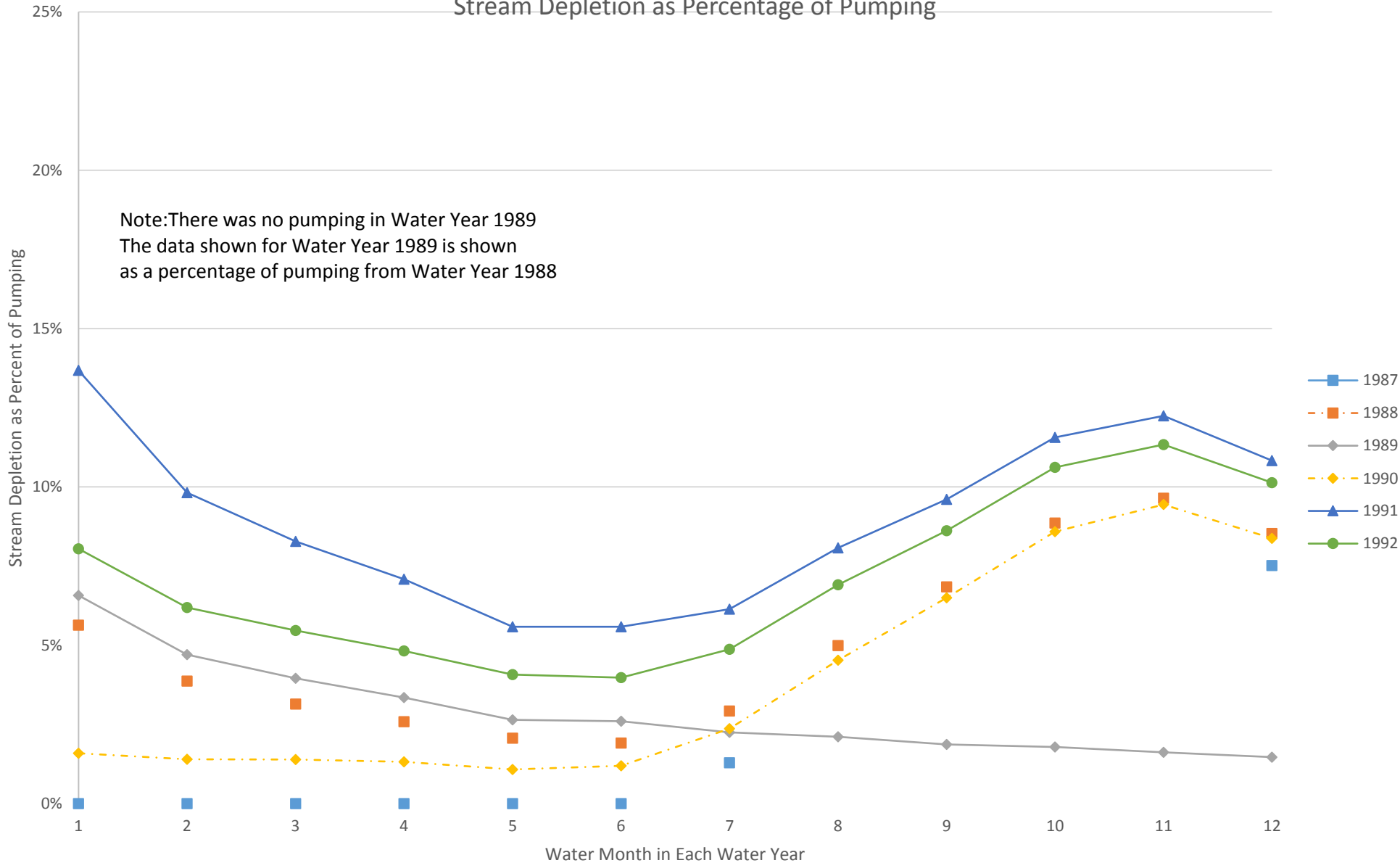
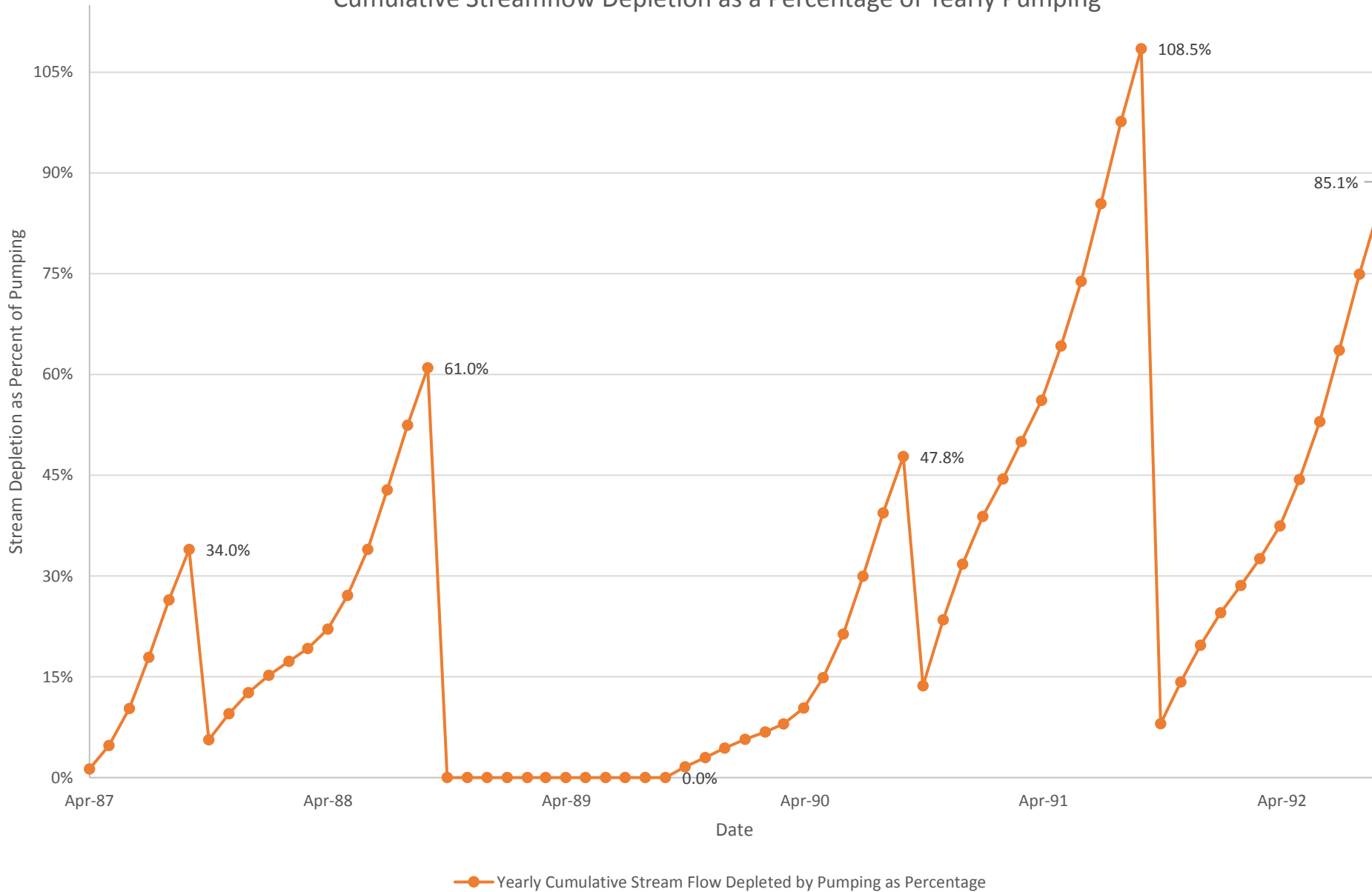

CHART A12: Sycamore Family Trust Node 66434
 Cumulative Streamflow Depletion as a Percentage of Yearly Pumping





ATTACHMENT B

**OVERVIEW OF IWFM SIMULATION CODE CAPABILITIES
AND C2VSIM-CG MODEL CONDITIONS ASSESSMENT FOR STREAMFLOWS**

Overview of IWFM

The Integrated Water Flow Model (IWFM) is a fully documented FORTRAN based computerized mathematical model that simulates ground water flow, stream flow, and surface water – ground water interactions. IWFM was developed by staff at the California Department of Water Resources (DWR). IWFM is GNU licensed software, and all the source codes, executables, documentation, and training material, are freely available on DWR's website.

The hydrological processes that are simulated in IWFM are the groundwater heads in a multi-layer aquifer system, stream flows, lakes (open water bodies), direct runoff of precipitation, return flow from irrigation water, infiltration, evapotranspiration, vertical moisture movement in the root zone and the unsaturated zone that lies between the root zone and the saturated groundwater system.

The interaction between the aquifer, streams and lakes as well as land subsidence, tile drainage, subsurface irrigation and the runoff from small watersheds adjacent to model domain are also modeled by IWFM.

IWFM is a water resources management and planning model that simulates groundwater, surface water, groundwater-surface water interaction, as well as other components of the hydrologic system. Preserving the non-linear aspects of the surface and subsurface flow processes and the interactions among them is an important aspect of the current version of IWFM.

Simulation of groundwater elevations in a multi-layer aquifer system and the flows among the aquifer layers lies in the core of IWFM. Galerkin finite element method is used to solve the conservation equation for the multi-layer aquifer system. Stream flows and lake storages are also modeled in IWFM. Their interaction with the aquifer system is simulated by solving the conservation equations for groundwater, streams and lakes simultaneously.

An important aspect of IWFM that differentiates it from the other models in its class is its capability to simulate the water demand as a function of different land use and crop types, and compare it to the historical or projected amount of water supply. The user can specify stream diversion and pumping locations for the source of water supply.

User-specified diversion and pumping amounts can be distributed over the modeled area for agricultural irrigation or urban municipal and industrial use. Based on the precipitation and irrigation rates, and the distribution of land use and crop types over the model domain, the infiltration, evapotranspiration and surface runoff can be computed. Vertical movement of the soil moisture through the root zone and the unsaturated zone that lies between the root zone and the saturated groundwater system can be simulated, and the recharge rates to the groundwater can be computed.

Overview of C2VSim- CG

C2VSim-CG Boundaries and Grid

The model encompasses approximately 20,000 square miles. The finite-element grid has 1393 nodes, 1392 elements.

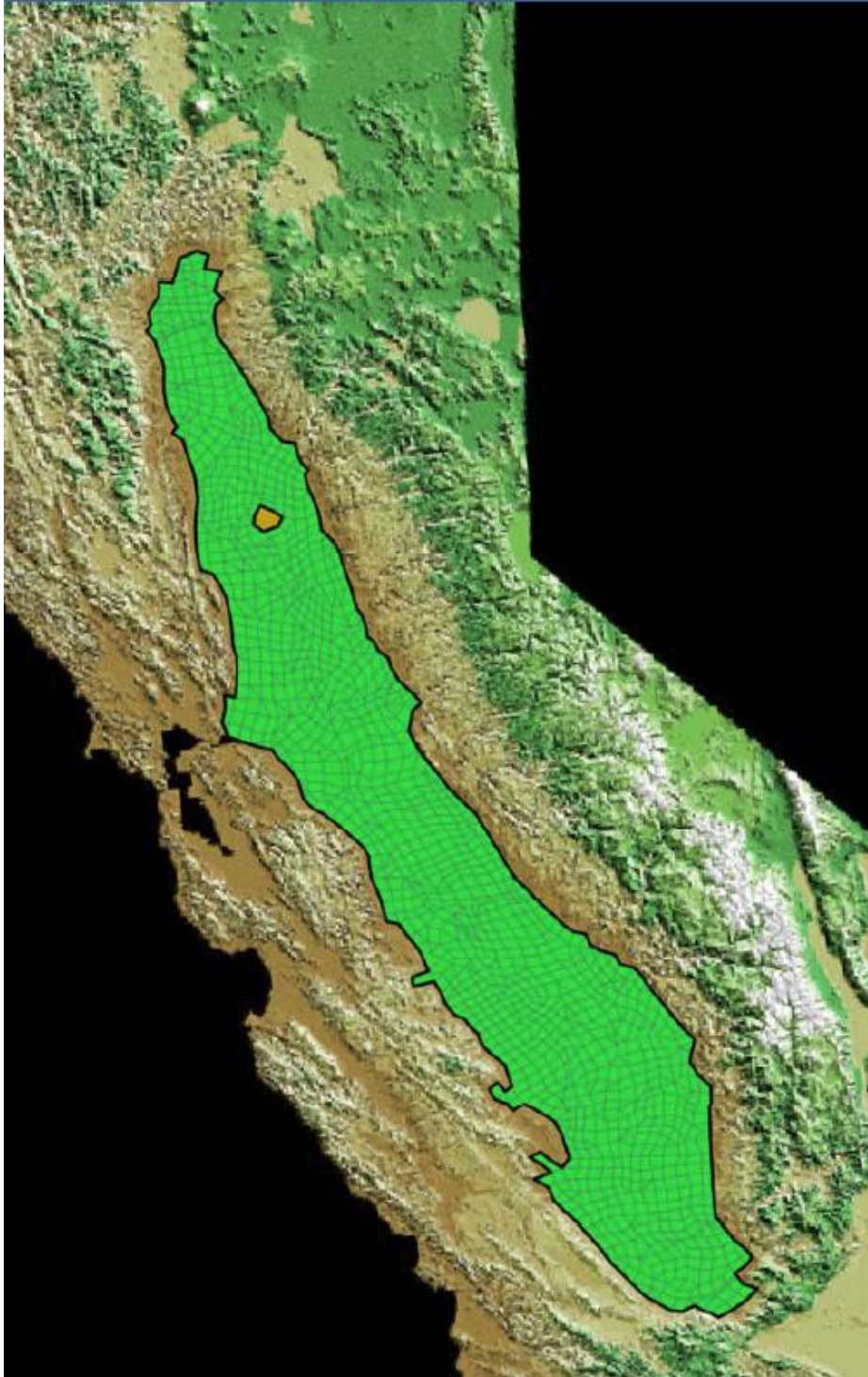

Model Layering

There are three explicit groundwater layers in C2VSim with two aquitards layers between the three layers. The bottom of layer 1 was specified to attempt to maintain a minimum saturated thickness of 100 ft except at the model lateral boundaries. The bottoms of layers 1 and 2 were set to incorporate the depth of most groundwater extraction well screens into one or both layers. The bottom of layer 3 was set at the base of fresh water

C2VSIM Land Use Process

For the land use process module C2VSIM defines 21 subregions that correspond to the Joint DWR-USBR Depletion Study Drainage Areas (DSAs)

The land use type modules that are simulated in the model are:

- Agriculture
- Urban
- Native
- Riparian

Watersheds and Streams

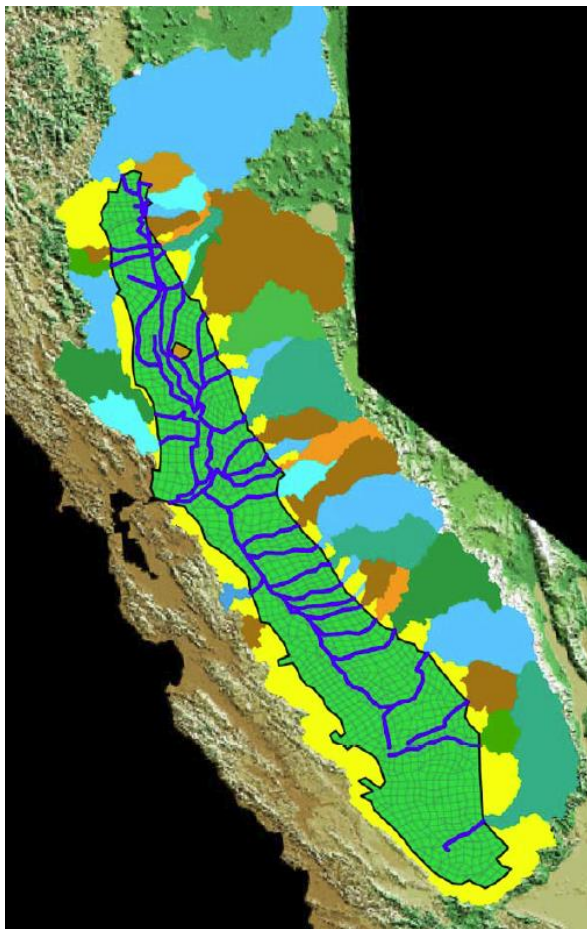

The model incorporates 72 stream reaches and 97 surface water diversion points. There are two lakes within the model domain. There are also

Major watersheds have gaged flows to C2VSIM streams. Minor watersheds are treated using IWFM Small Watersheds process module.

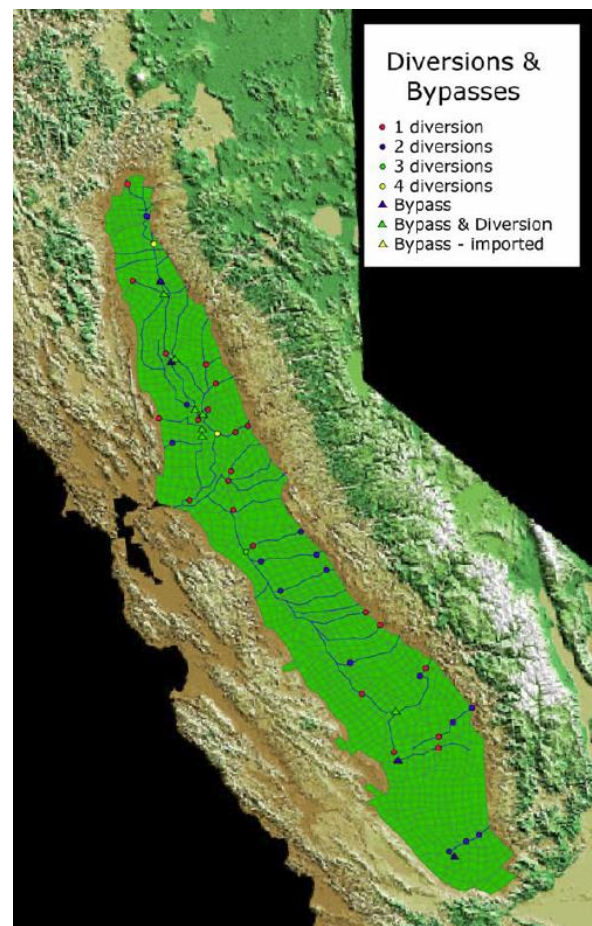

eight flood water bypass canals modeled as surface water diversions in the domain but with their own hydraulic characteristics to differentiate them from other diversion points.

Model Input Parameters

Precipitation Stations and Zones

The model inputs were derived from 32 precipitation stations. Monthly precipitation data from October 1921 to September 2009 were input to the model. Elemental multipliers were used to match the monthly precipitation arrays from the Precipitation Regression Inverse Slope Model (PRISM) 1971-2000 from Oregon State University

Hydraulic Parameters

Horizontal hydraulic conductivity

- 20 – 80 ft/day in layers 1 and 2
- 5 ft/day in layer 3

Vertical hydraulic conductivity

- 5×10^{-5} – 1×10^{-3} ft/day

Specific yield

- 0.12 – 0.18

Specific storage

- 2×10^{-5} ft⁻¹

C2VSIM calibration

C2VSIM calibration was done in an organized sequence of steps. The first step was to update the Conceptual Model for:

- Small watershed delineation
- Precipitation data and stations
- Model Layering and Thicknesses
- Initial heads
- Stream-bed elevations
- Rainfall Runoff Uniform Curve Numbers
- Agricultural root-zone process

The calibration data used included:

- 1976 water level maps for layers 1 & 2
- Head observations at 221 wells
- Single screen coincides with model layering
- Measurements before 1977 and after 1997
- No more than one well per model element
- Vertical head gradients at 9 locations
- Average stream accretions and depletions

Calibration was done using PEST with Pilot Points to do inverse parameter fitting to achieve best estimates of parameters to fit through observations (i.e. field data). The calibration sequence used was:

1. *Land use process*
 - Agricultural root-zone process
 - Curve numbers
2. *Groundwater flow system*
 - Hydraulic conductivity of layers 1 & 2
 - Vertical anisotropy
 - Specific yield in layer 1
3. *Surface water flow system*
 - Stream-bed conductivity

Calibration Results

Water Levels:

- Layer 1 generally good
- Layer 2 high beneath Corcoran Clay

Spatial correlation of head residuals

- Reasonable in Sacramento Valley (low on western edge)
- Low in western San Joaquin Valley
- High beneath Corcoran Clay
- Simulated water level trends match observed water level trends on a regional basis

Results - Heads

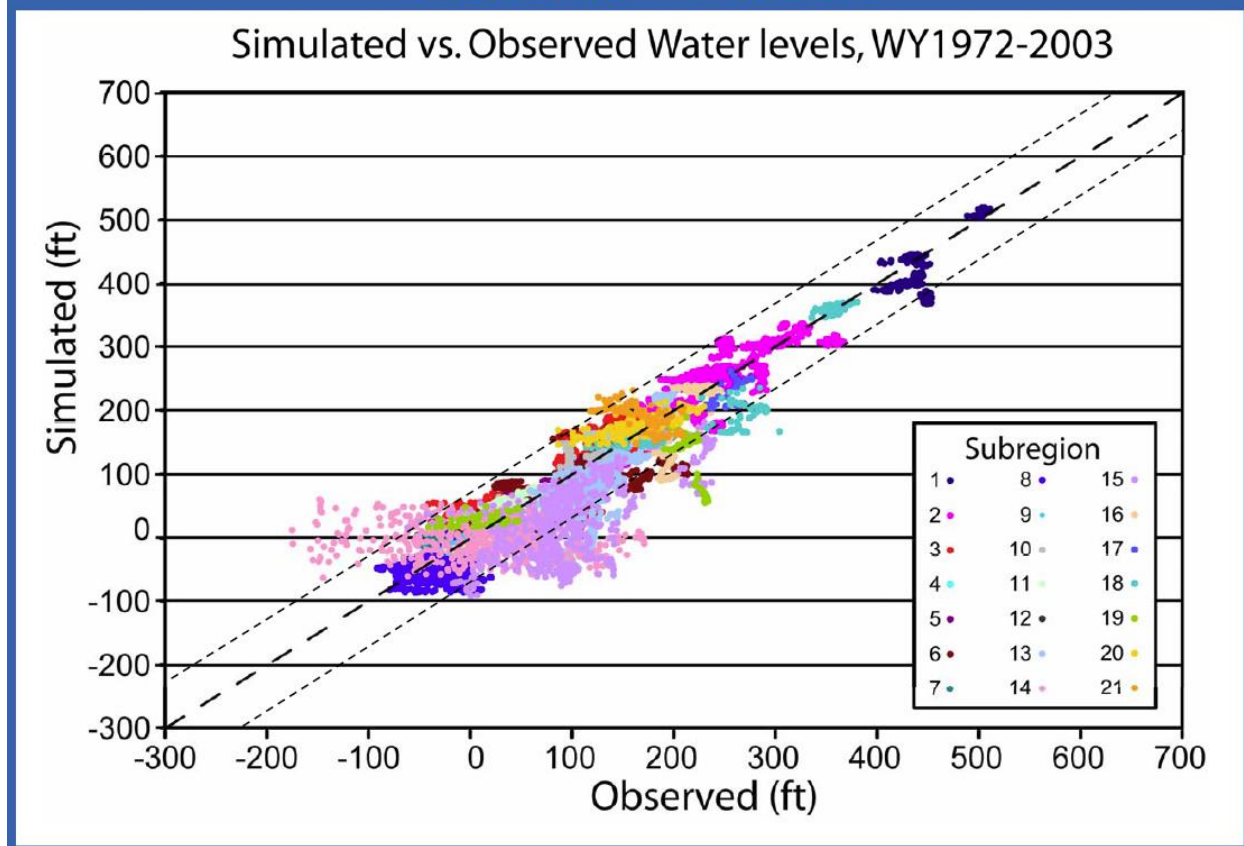

Hydraulic Conductivities

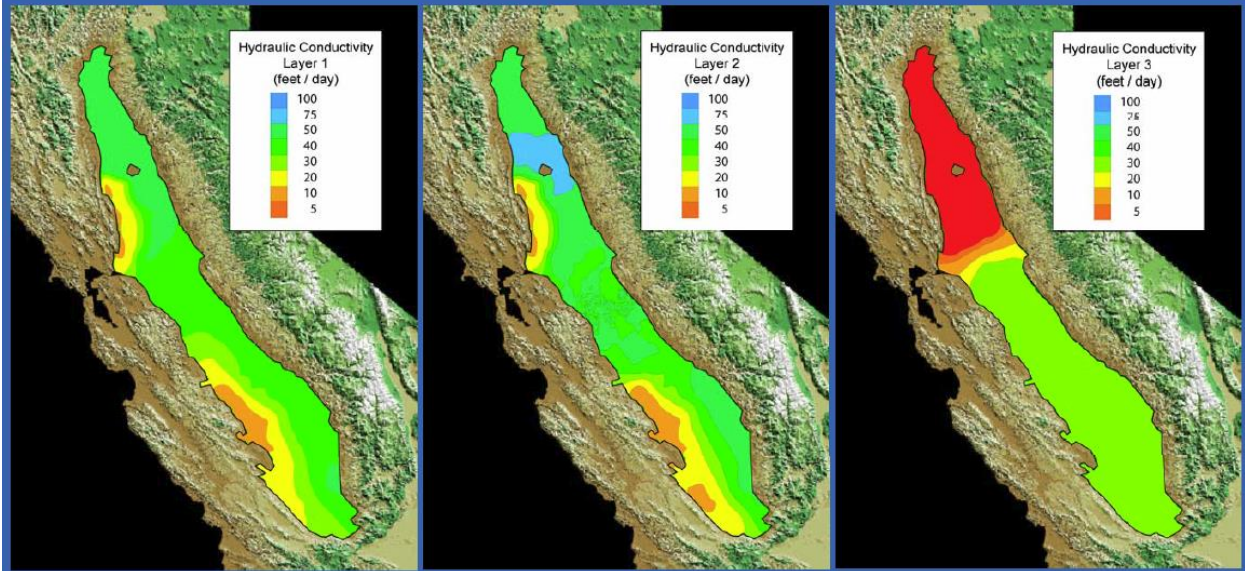

Water Budget Items

C2VSIM shows net groundwater discharge to streams. C2VSIM simulated stream accretions and depletions have same sign as observed, and magnitude is close

Results - Flows

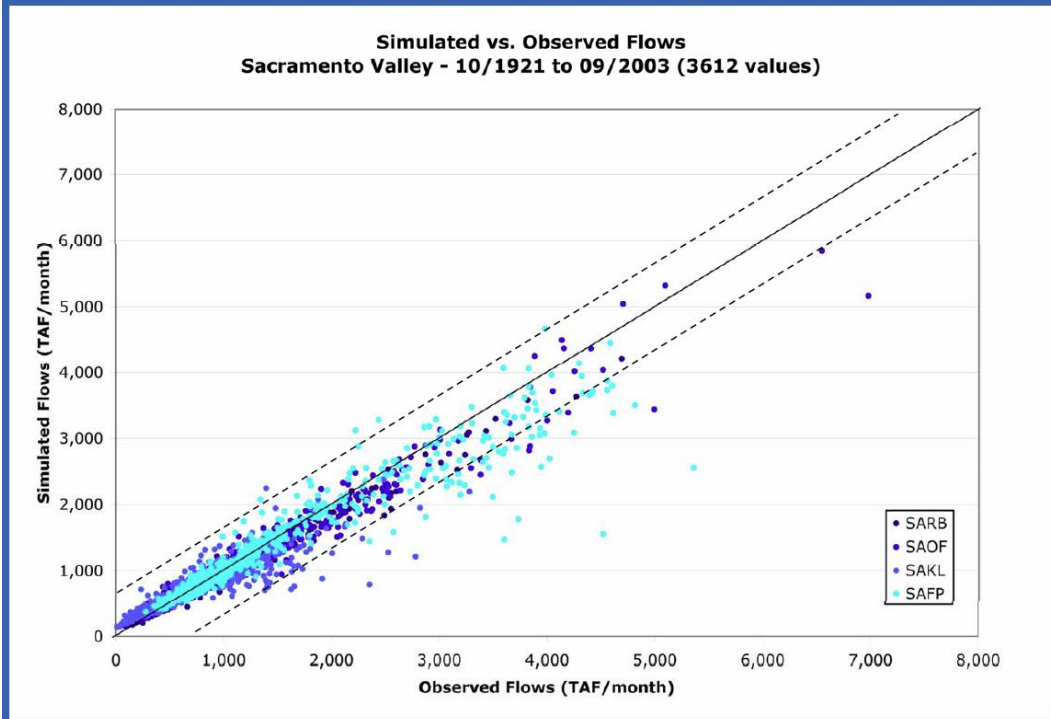

Results - Flows

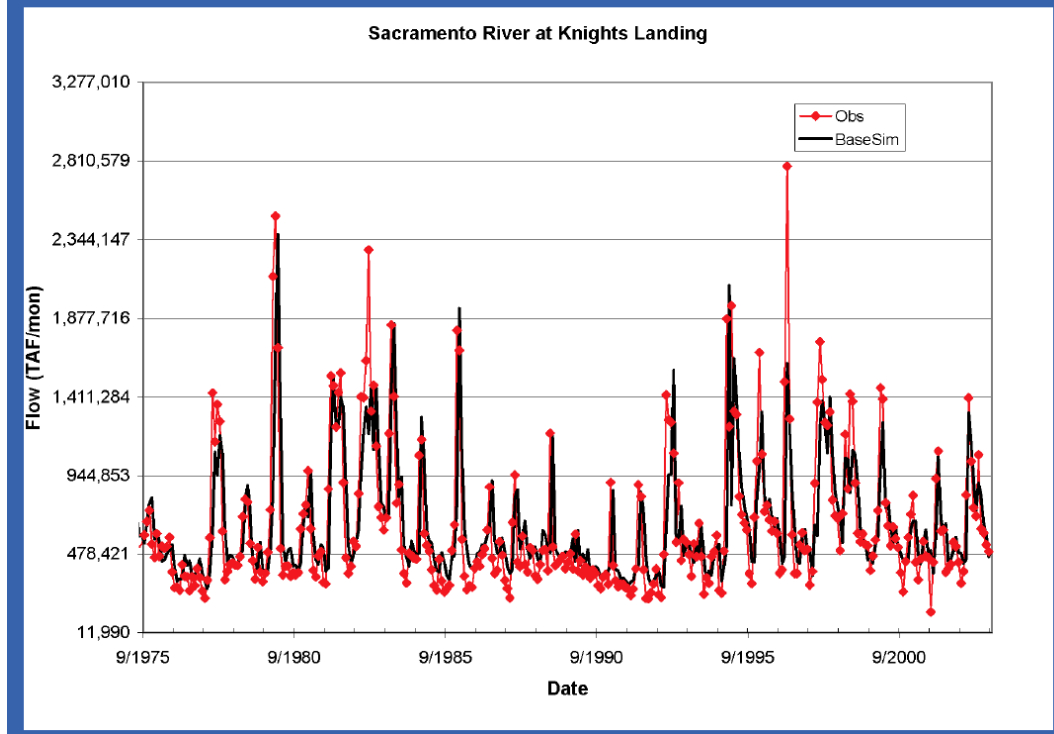



ATTACHMENT C
REVIEW OF SACFEM 2013 CONSTRUCTION AND CALIBRATION

SACFEM2013 Model Notations

SACFEM2013 is built using the MicroFEM simulation code. MicroFEM as a groundwater simulation code cannot accurately calculate some of the key physical processes in the water budget such as evapotranspiration within a shallow groundwater aquifer. It is unable to simulate the physical processes and fully account the changes in surface water flow and groundwater to surface water exchange. A proper basis for the selection of a proprietary model code, that has not been independently verified as to its numerical solution's accuracy, and that does not contain necessary algorithms and proper mathematical formulations to the questions at hand, is not provided in Appendix D.

72

The EIS/EIR in Appendix B states:

“SACFEM2013 is a full water budget based, transient groundwater flow model that incorporates all groundwater and surface water budget components on a monthly time-step over the period of simulation. SACFEM2013 provides very high resolution estimates of groundwater levels and stream flow effects due to groundwater pumping within the Sacramento Valley.”

This statement is not accurate and is notably not repeated in the text of Appendix D.

Review of Appendix D on SACFEM2013 Documentation

The documentation of SACFEM2013 is grossly inadequate. The documentation of SACFEM2013 is less than that found for SACFEM in 2011. There is no calibration data provided. No discussion of model residuals or fit to any type of observed data. There is no quantification of model uncertainty or limitations provided in Appendix D. In our review we have been unable to comprehend the model from its documentation. Instead it has required exploring primary data inputs through the GIS database from which it was constructed.

73

SACFEM2013 is built in Version 4.10 of MicroFEM. No documentation for this version of the code is cited or provided.

Vertical Structure goes to base of the freshwater aquifer and treats that boundary as a no-flow boundary.

Boundary Conditions

Head Dependent Boundaries

Surface Water fluxes

- 50 individual streams are simulated using the “wadi” package in the current version of SACFEM2013
- User specified stream stage
 - Transient monthly “varying distributions” of stream-stage height were developed for each reach with no documentation of how this was calculated)
 - User specified stream stage imposes error on model outcomes
- Model calculated head is driver on gradient vs. user specified stage.
- Streambed Conductance (from subformula)
 - D_r = streambed thickness = uniformly assumed to be 1 meter

74

- K_v = streambed conductivity (
 - Assumed to be 2 meters/day on the eastside, and
 - 5 meters/day on the westside, two exceptions on Eastside for Bear River and Big Chico Creek)
 - **Review and use of model input data K_v as found in the GIS files to the Delta Water Agencies found K_v values in the eastside ranging from 1 meter/day to 0.1 meter/day in the locations selected.**
- L = stream length represented by the model node
- A = nodal area
- W = “field width” of the reach represented by L
 - Wetted Stream width taken from aerial photographs at two locations

74

Appendix D comments that stream length is generally overestimated at river confluences. Manual adjustments were noted without description of how these were calculated.

Streambed elevations were developed from a DEM; there is an odd note of the DEM resolution being lower than stream node resolution when stream node resolution is reported to be on the order of 250 meters and conventional DEM resolution is on the order of 10 to 30 meters with a precision of plus/minus approximately 8 feet.

Drains

SACFEM2013 used the Drain package to simulate the upper land-surface groundwater boundary condition across the domain. Efflux nodes only that are head dependent. Elevation of drain set at land surface. Why were drains not set to the root zone depth to represent ET from the groundwater domain? Formulas provided for the drain stage are underdocumented

75

Specified Flux Boundaries

These denote boundaries where a influx or outflux of water occurs at a set rate per period that is user specified and not model calculated. Specified flux boundaries were set for:

- Deep Percolation
- Mountain Front Recharge
- Urban Pumping

Deep percolation of water

This was reportedly done by surface water budget approach

- Water budget estimated using spatial information
 - Land use
 - Cropping patterns
 - Source of Agricultural Water
 - Surface water availability in different year types and locations
 - Spatial distribution of precipitation
- Components
 - Deep percolation of applied water
 - Deep percolation of precipitation
 - Agricultural pumping
- Developed by intersecting

76

- GIS data developed by DWR (no citation) – Transient Condition on Land Use
- With SACFEM model grid
- Results in a land use for each groundwater model node
- GIS data on water district and non-district areas derived
- Water source information to the areas (where does this come from? – no citation or methodology described)

76

Methodology for Surface Water Budget

The methodology is underdocumented. Semi physically based soil moisture accounting model used; it is not clear if this is IDC

Historic precipitation data

Simulates root zone processes and calculates applied water demand and deep percolation past the root zone for each node.

Deep percolation was split between applied water and precipitation. Split was dependent on the season and availability of water from each source

Their calculated values for deep percolation were reportedly compared to DWR Estimated Values for the Year 2000 (no citation). They corresponded with DWR Northern District staff (no citation of who) They adjusted soil parameters in root zone model to reportedly match volumes of percolation to DWR (no citation of DWR data source nor provision of data).

77

Agricultural Pumping calculated from demand for applied water (**no mention found of crop typing or climatic drivers on water demand for applied water**) compared to source water availability from surface sources via GIS intersection of districts

- Split out of groundwater and surface water for certain areas
- Or all groundwater
- Mention of a “level of development simulation of CVP operations” was used to calculate availability of surface water
- Agricultural pumping applied to Layers 2, 3, and 4 only. **There is no clear basis for this placement of pumping.**

Mountain Front Recharge

Utilized an annual formula from Turner 1991 for a Mediterranean climate and converted the total deep percolation estimated per upper watershed into monthly quantities by looking at streamflows in “ungauged” sections of Deer Creek. Water inserted into Layer 1 at the model boundary.

78

Urban Pumping

Used groundwater use data from Urban Water Management Plans, for population centers above 5,000 people that rely on groundwater. For areas that did not have UWMPs used 271 gpd per person times census to get to groundwater use. Areas of North Sacramento County pumping/usage were stated as consistent with the local SacIGSM model (Note that SacIGSM is built in a predecessor code to IWFM)

79

No Flux Boundaries

Bottom of Layer 7, the freshwater interface.

80

Aquifer Properties

To develop hydraulic conductivity they reportedly used 1,000 wells within model domain with construction information and specific capacity data on Well Completion Reports. Shallow wells (<100 feet) and those with production below 100 gpm were eliminated for aquifer properties (except at the margins of the model domain where aquifers were presumed to be thin). Specific capacity data were converted to calculated transmissivity (T) using an empirical method that is not accurate. A specific capacity can be strongly influenced by turbulent head losses at the well if the pumping rate of the well is high relative to the length of well screen and the well screen open area. The calculated T value was reportedly divided by screen length to derive initial K_h .

They state there is not enough data to define depth dependent K_h . Cooper-Jacob confined aquifer method was assumed in their analysis of aquifer transmissivity.

81

Peer Review Comments

Deep Percolation

- IDC calculated deep percolation rates are excessive
 - Deep percolation reduction factors were created for IDC outputs before use in SacFEM
- SacFEM deep percolation rates are not supported by the fundamental IDC model methodology and parameters resulting in a disconnect between SacFEM and IDC.
 - Recommended incorporating a feedback loop between the 2 models and subjecting them to convergence criteria
 - SacFEM deep percolation rates are not consistent with other data sets and it should be ensured that they are supported by historical land use, crop mix, and agricultural practices

82

Stream Aquifer interaction

- The flow exchanged between streams and aquifers is a function of head difference between groundwater elevation and stream stage with impedance by streambed resistance.
- The assumption of constant stream stage results in stream-aquifer relationship dependent on streambed resistance and groundwater elevation
- Assumption of constant stage is not valid
- Recommended that SacFEM use time varied stream stage data

83

The 2011 peer review contained a primary statement of revisions to SACFEM from 2009 that:

“Documentation on SacFEM and the IDC Model – Model documentation, with appropriate level of detail on data collection, analysis, and input data preparation should be developed.”

Model Calibration Information

The following model calibration figures were obtained from the 2009 and 2011 SACFEM model documentation.

DOCUMENTATION OF THE SACFEM GROUNDWATER FLOW MODEL

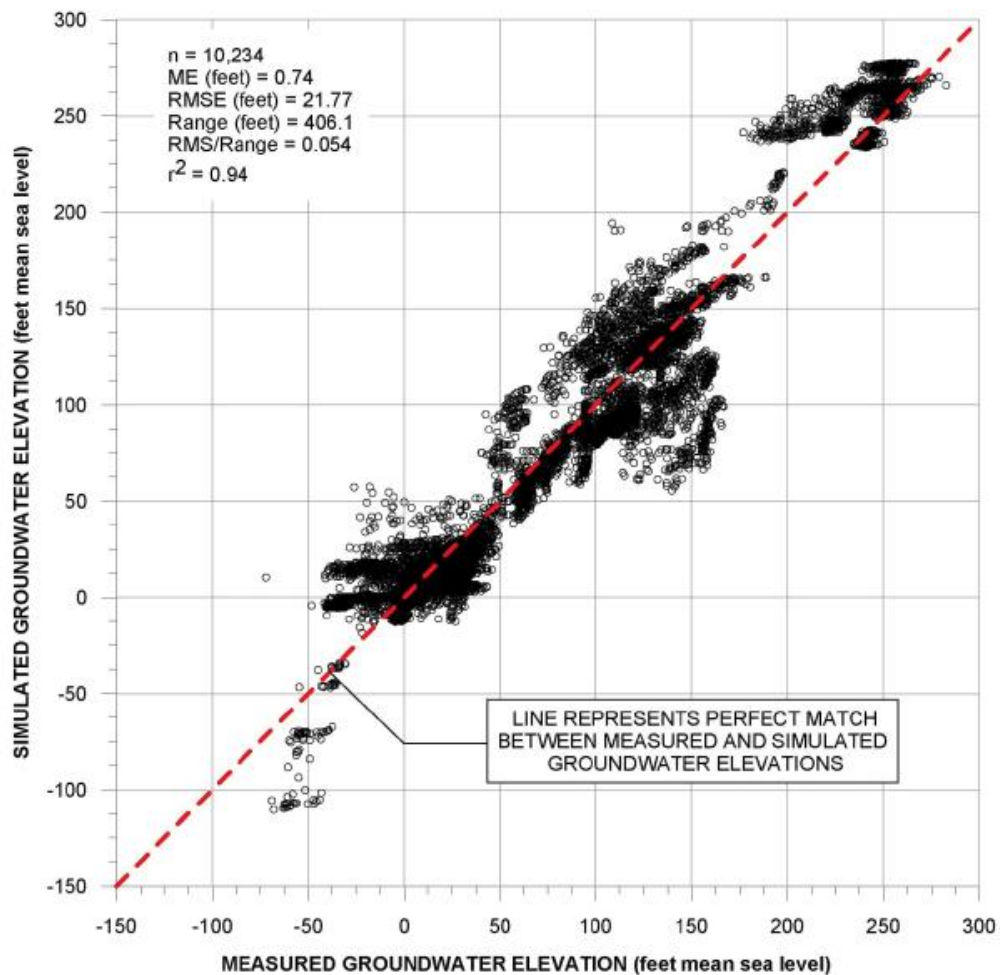
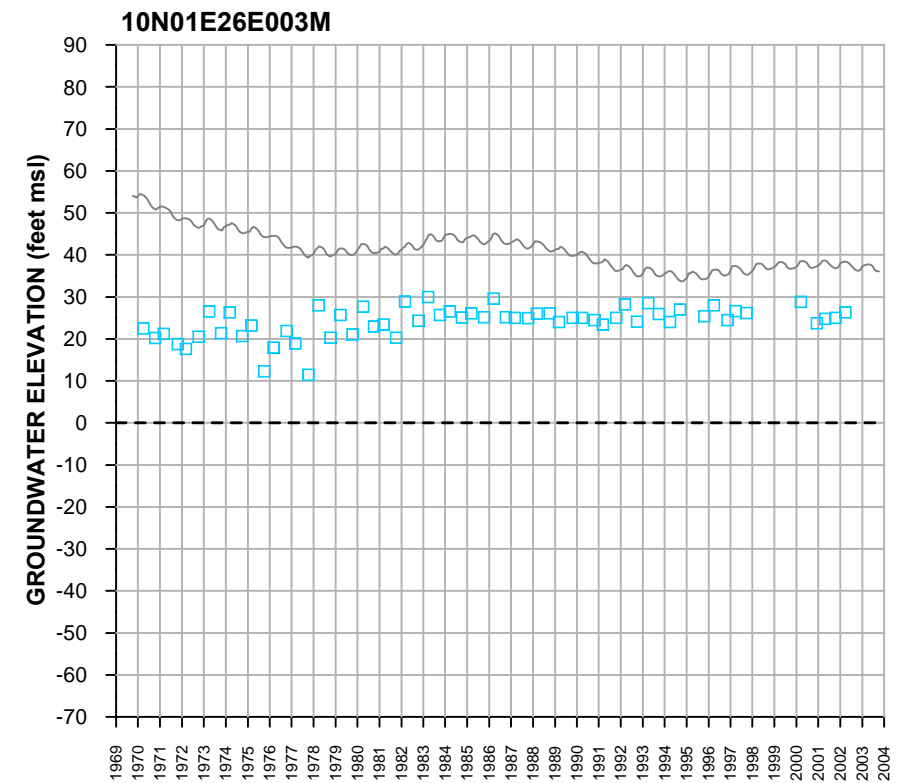
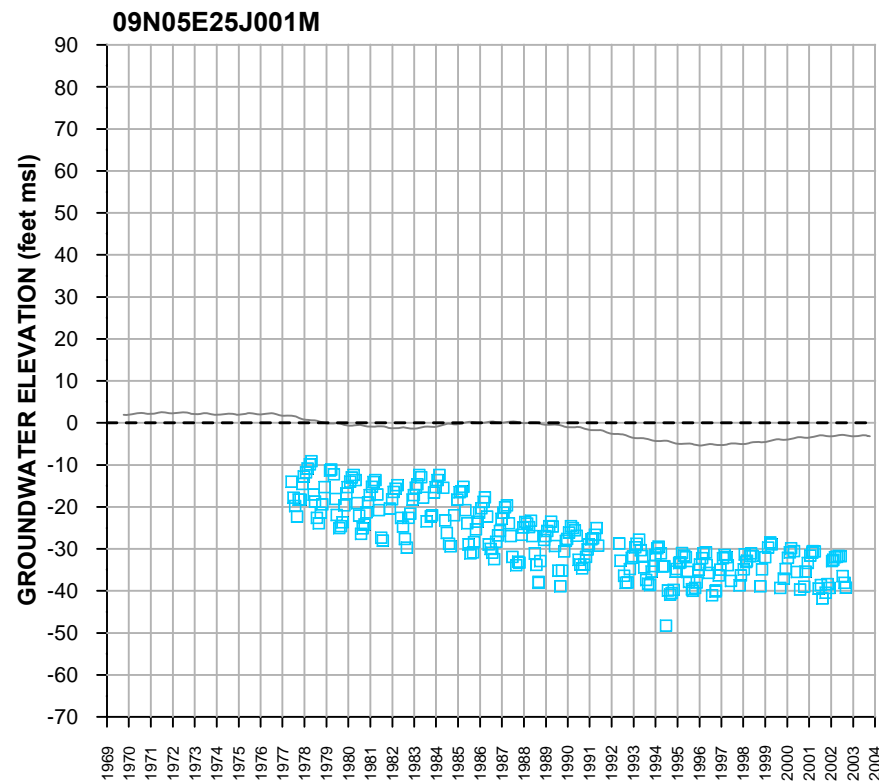
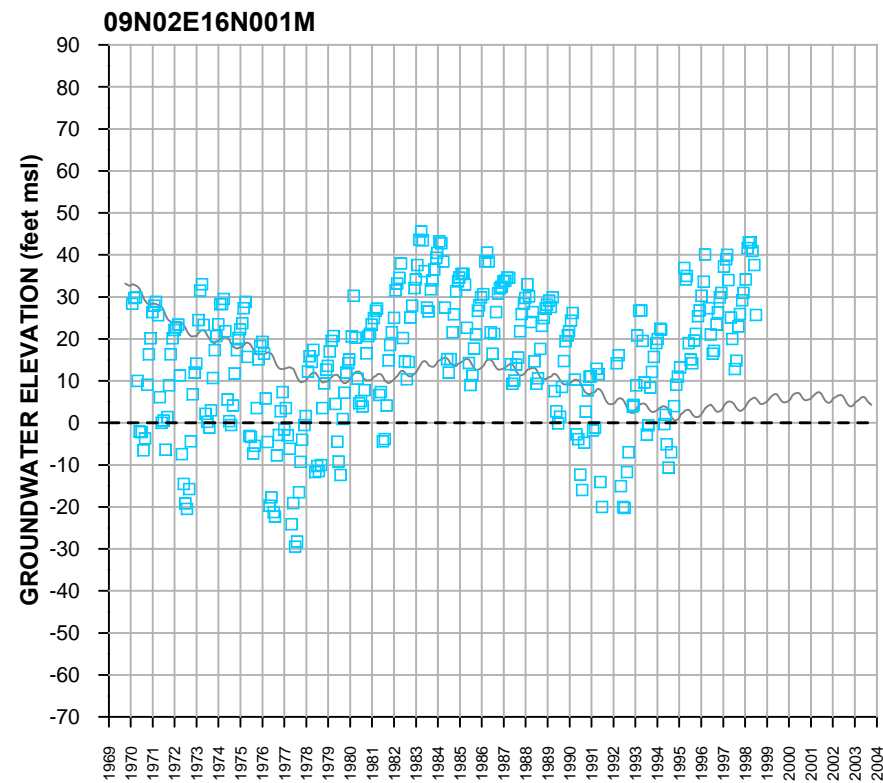
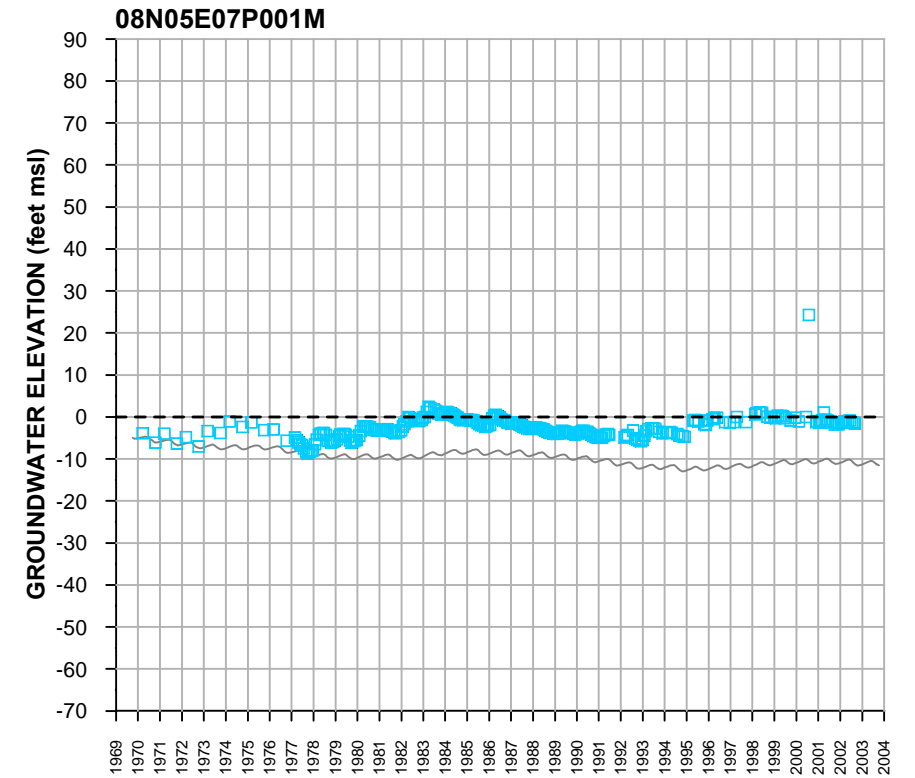
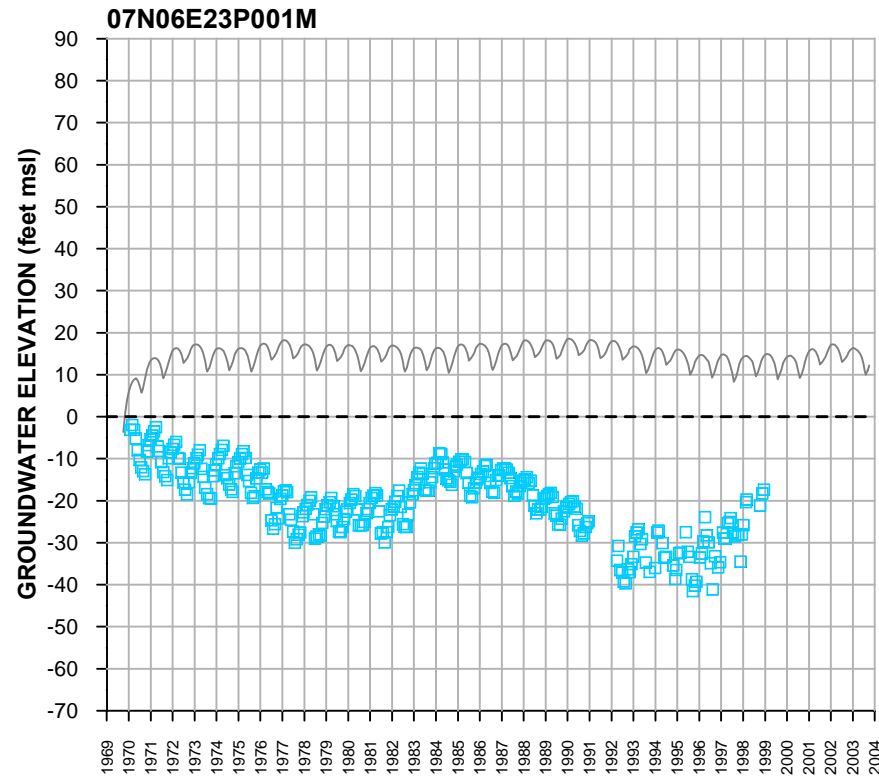
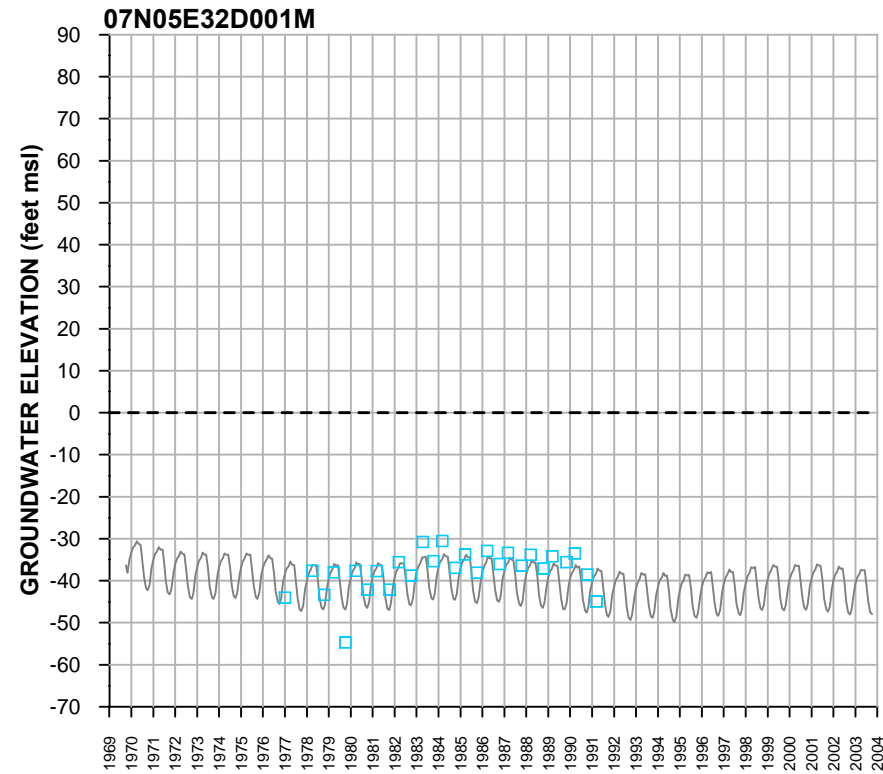

FIGURE B-9
Transient Calibration Scattergram

This model calibration demonstrates that in several areas model estimates exceed actual measured data by more than 65 feet, the thickness of Layer 1 in SACFEM2103. This is notable in the region around 150 feet MSL on the attached chart, B-9, found in the 2011 model documentation. Additional calibration figures by well are found on the pages that follow and demonstrate a lack of fit to trend or data at many wells.



LEGEND

- MEASURED GROUNDWATER ELEVATION (feet msl)
- SIMULATED MONTHLY GROUNDWATER ELEVATION (feet msl)
- - - MEAN SEA LEVEL (feet msl)

FIGURE B-10 (PAGE 2 of 11)
TRANSIENT CALIBRATION HYDROGRAPHS
 DOCUMENTATION OF THE SACFEM
 GROUNDWATER FLOW MODEL
 SACRAMENTO VALLEY GROUNDWATER BASIN
CH2MHILL

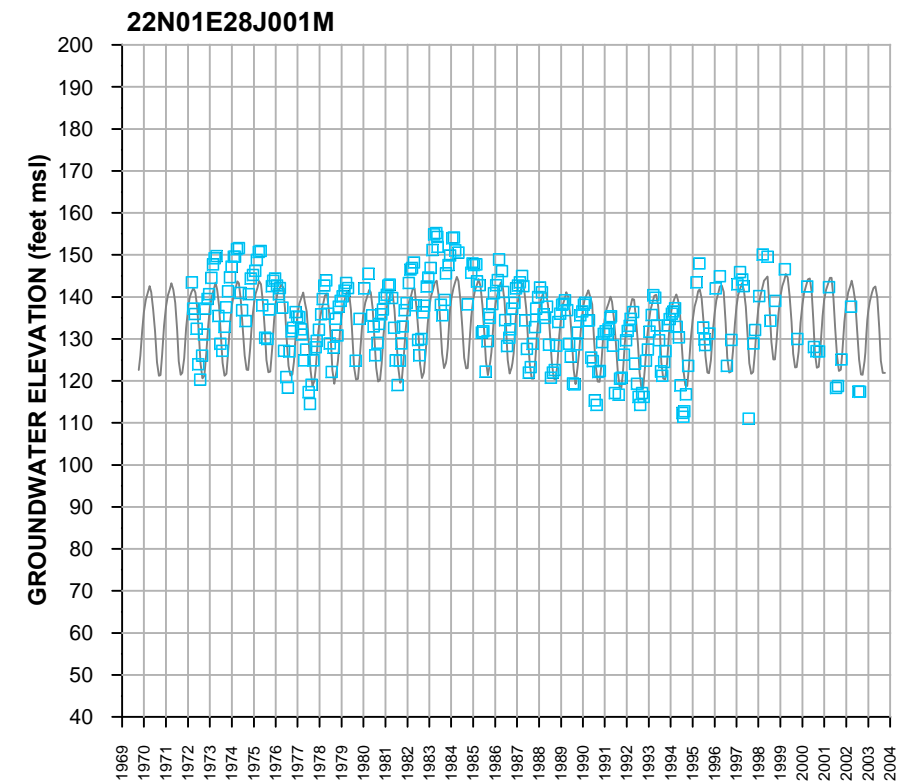
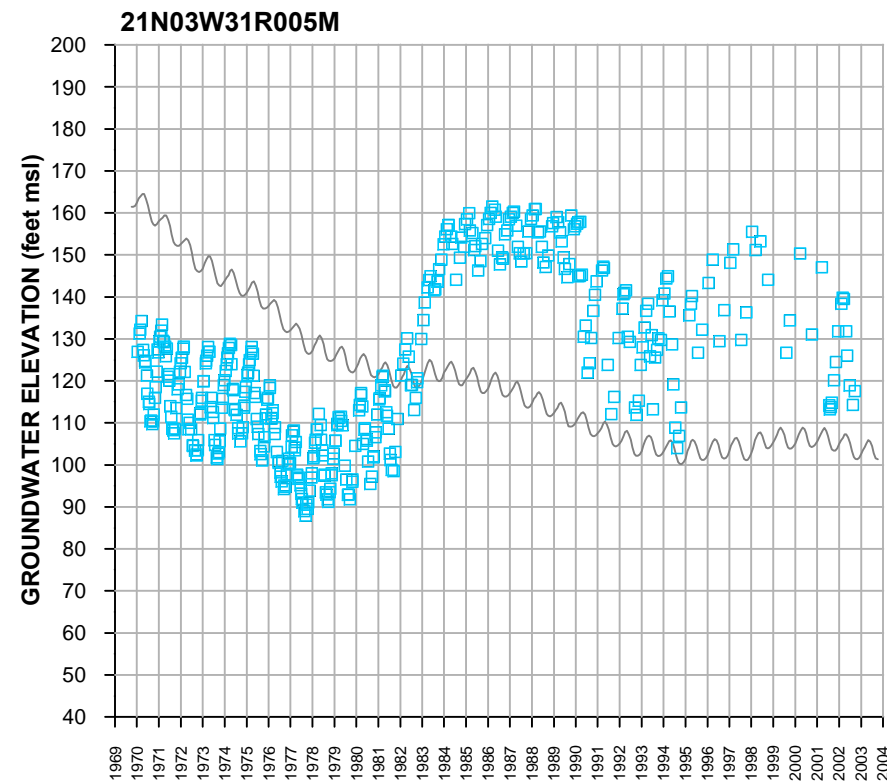
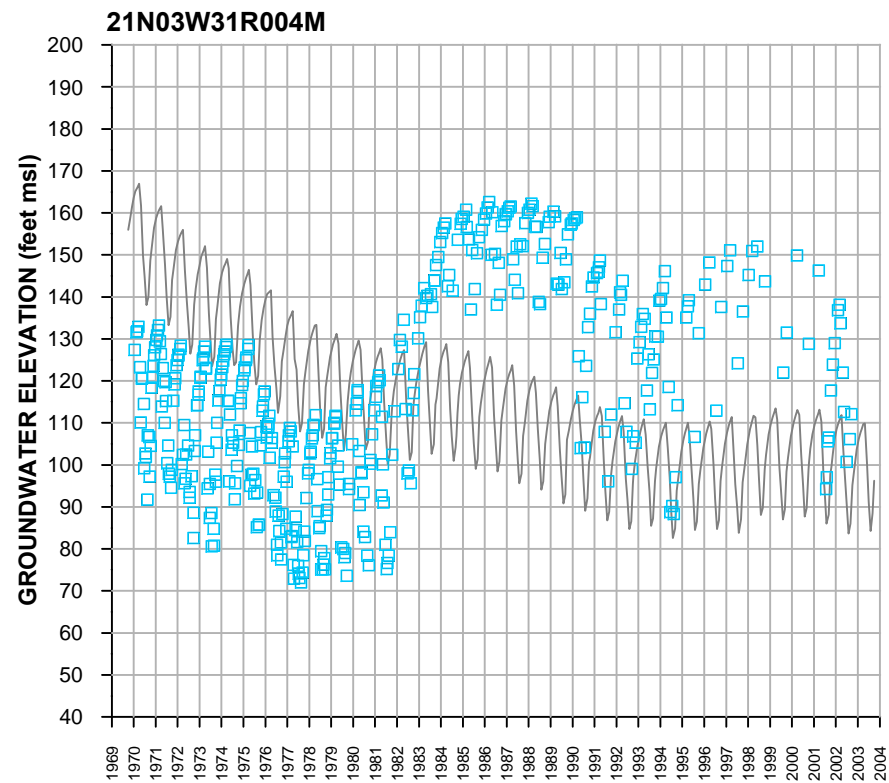
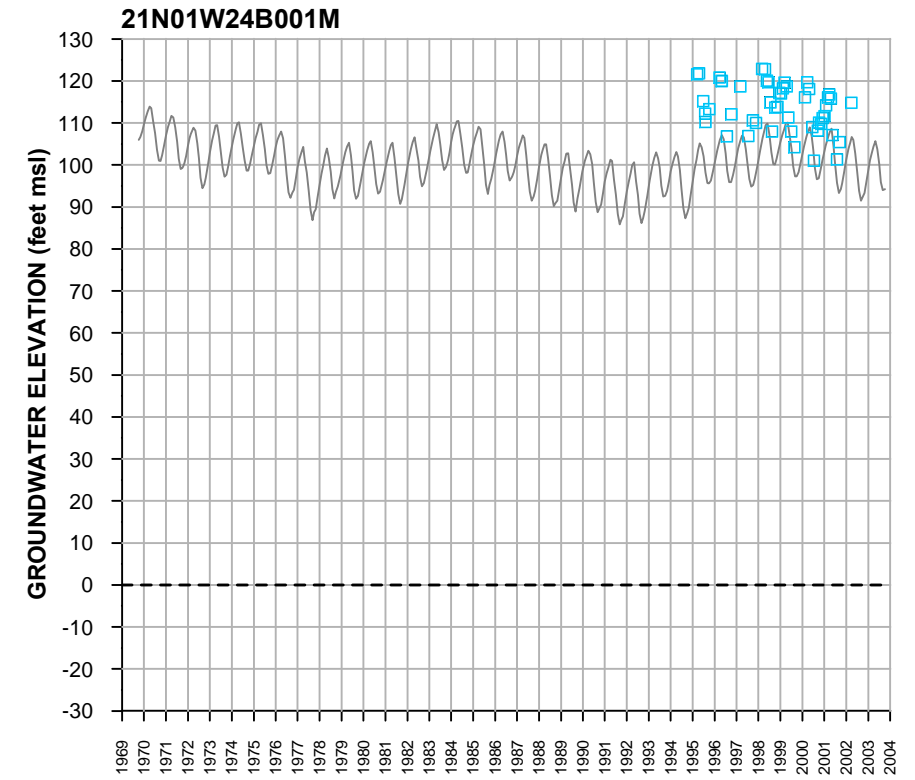
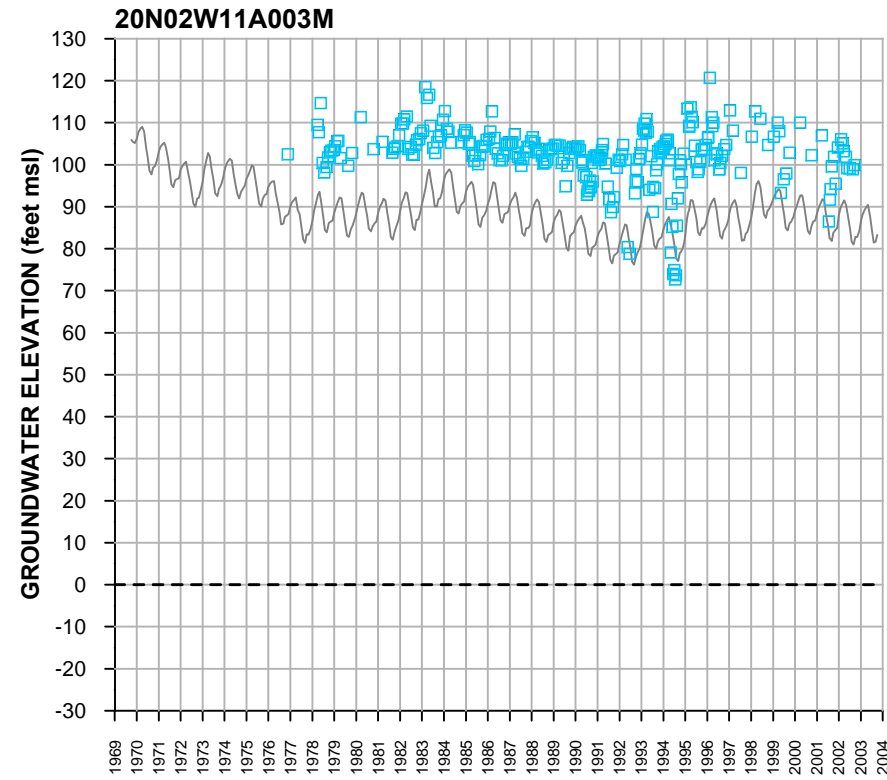
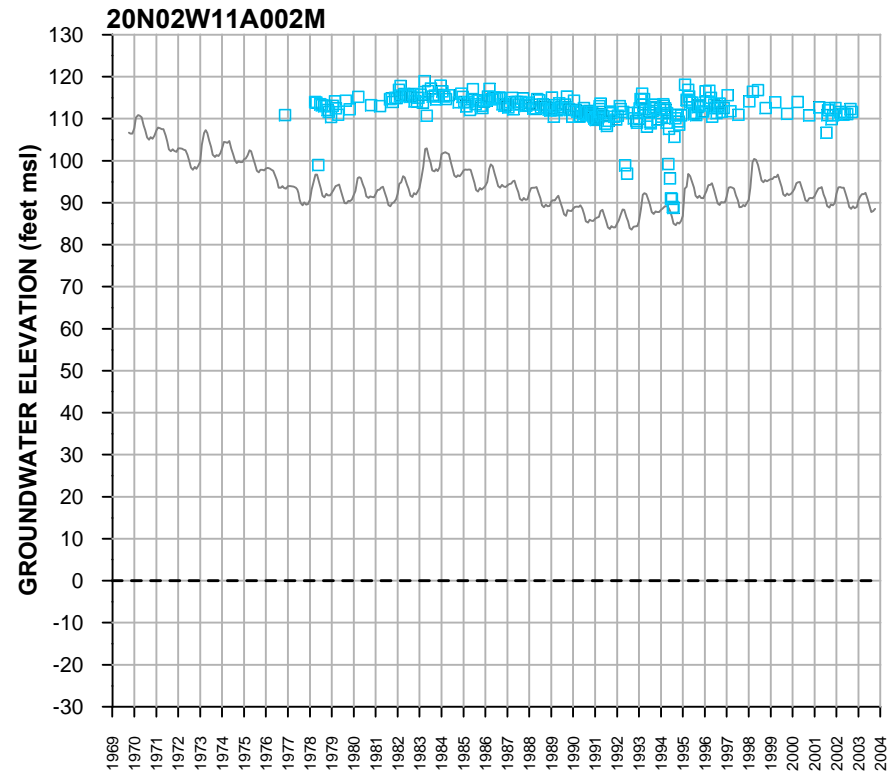

LEGEND

- MEASURED GROUNDWATER ELEVATION (feet msl)
- SIMULATED DAILY GROUNDWATER ELEVATION (feet msl)
- - - MEAN SEA LEVEL (feet msl)

FIGURE B-10 (PAGE 8 of 11)
TRANSIENT CALIBRATION HYDROGRAPHS
 DOCUMENTATION OF THE SACFEM
 GROUNDWATER FLOW MODEL
 SACRAMENTO VALLEY GROUNDWATER BASIN

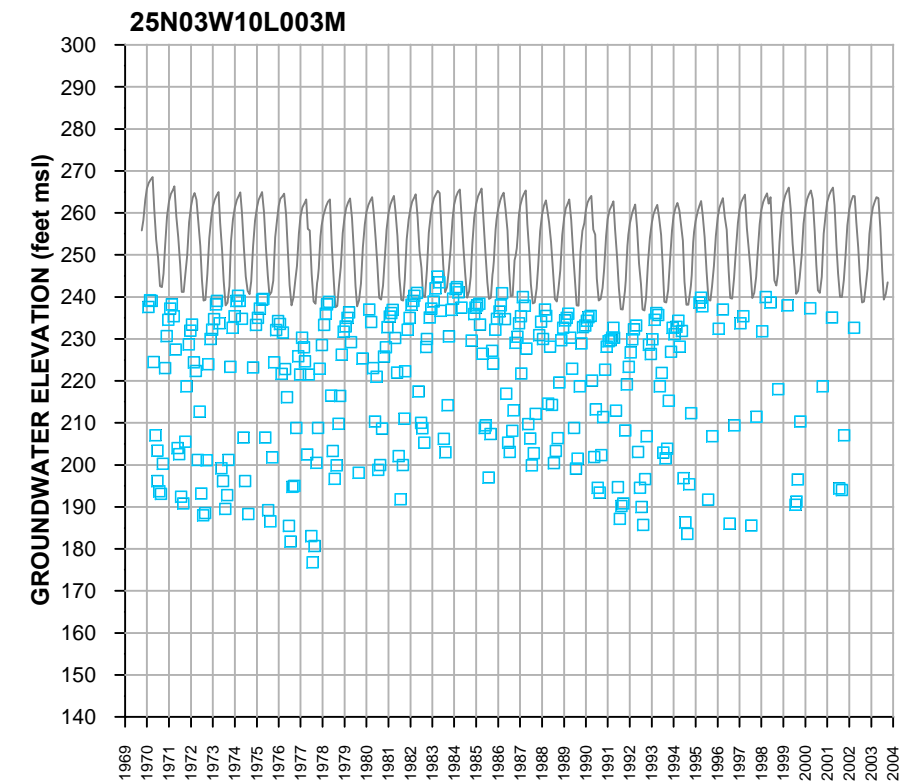
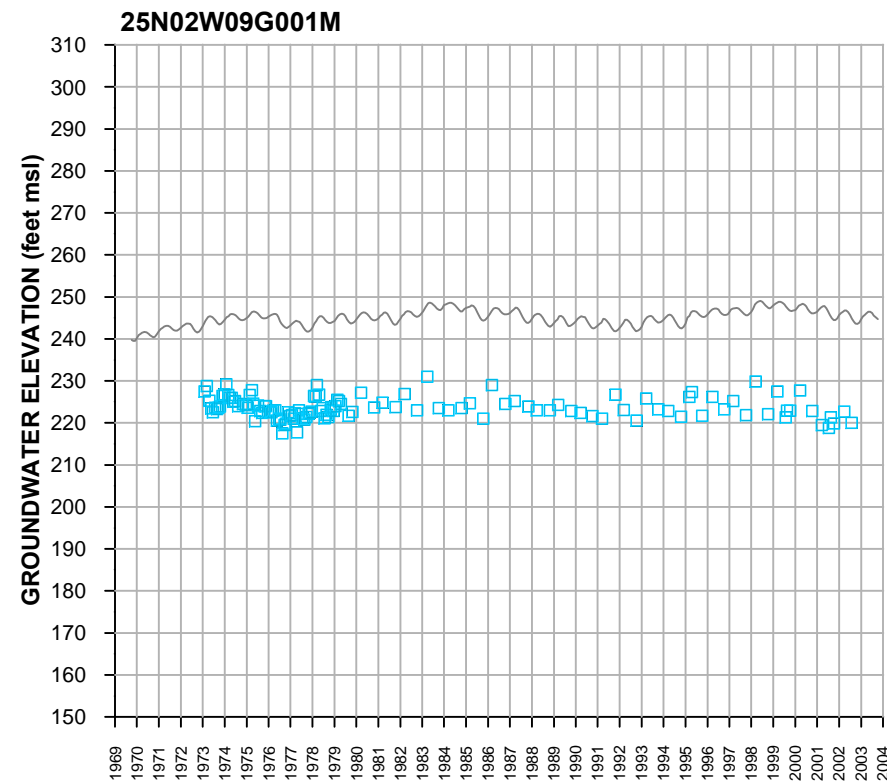
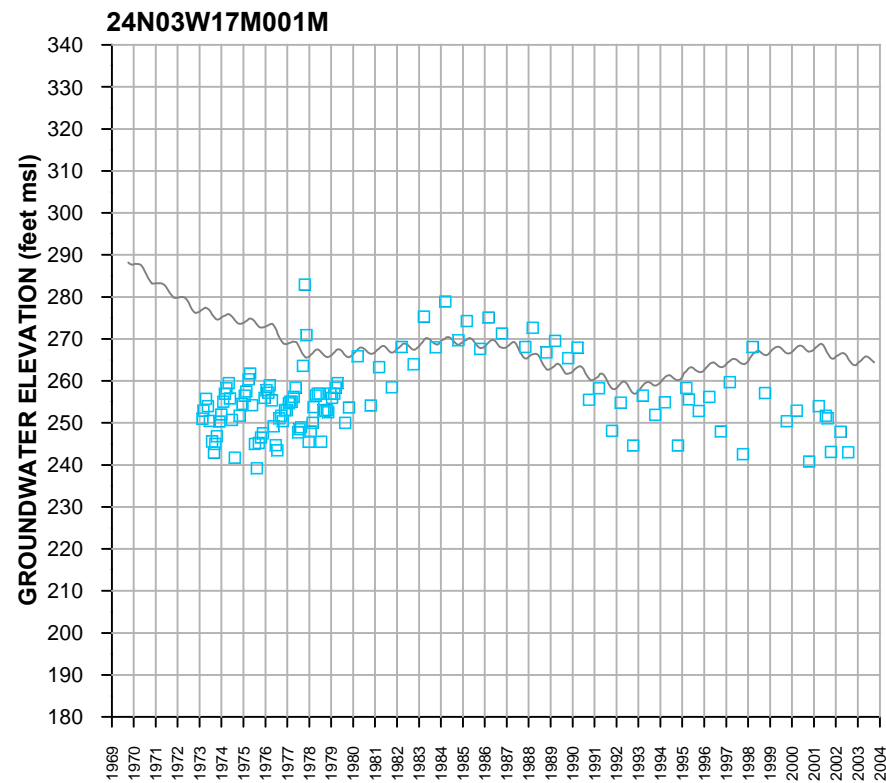
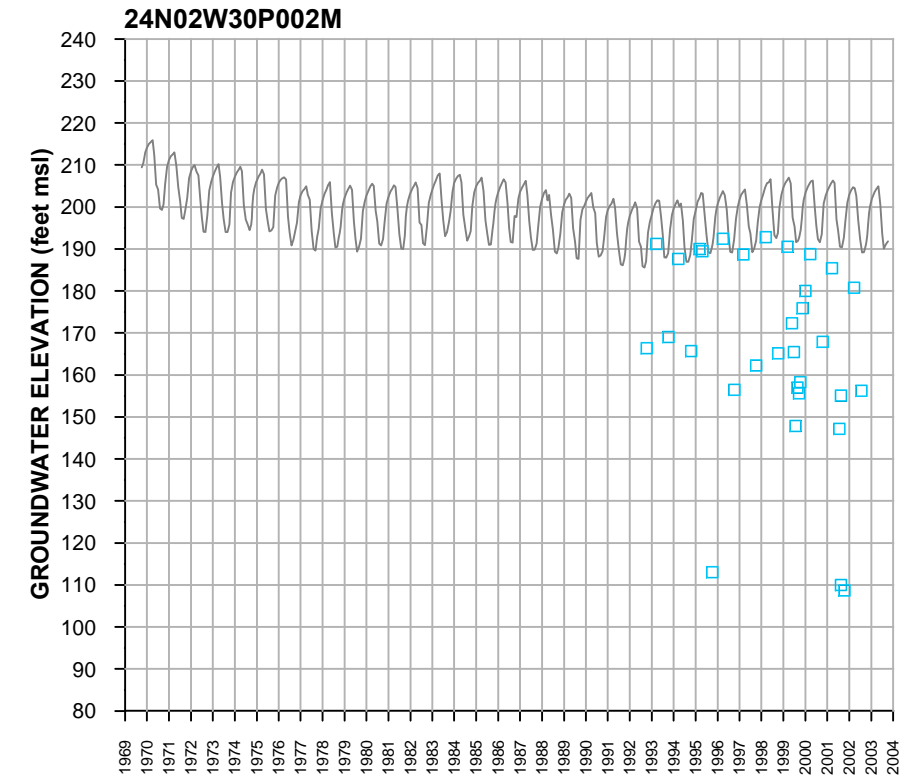
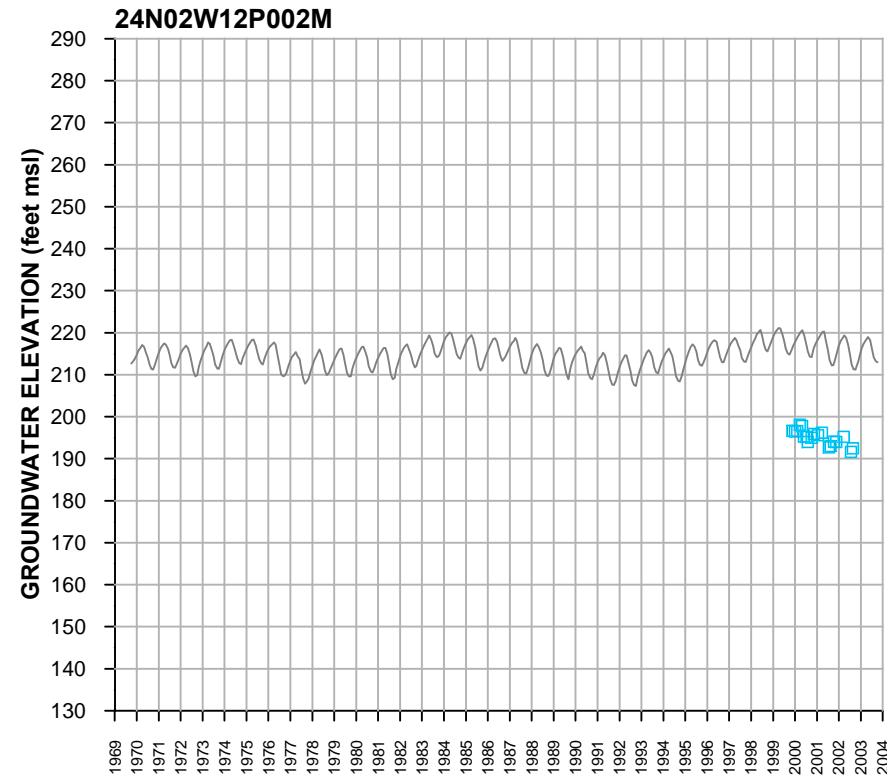
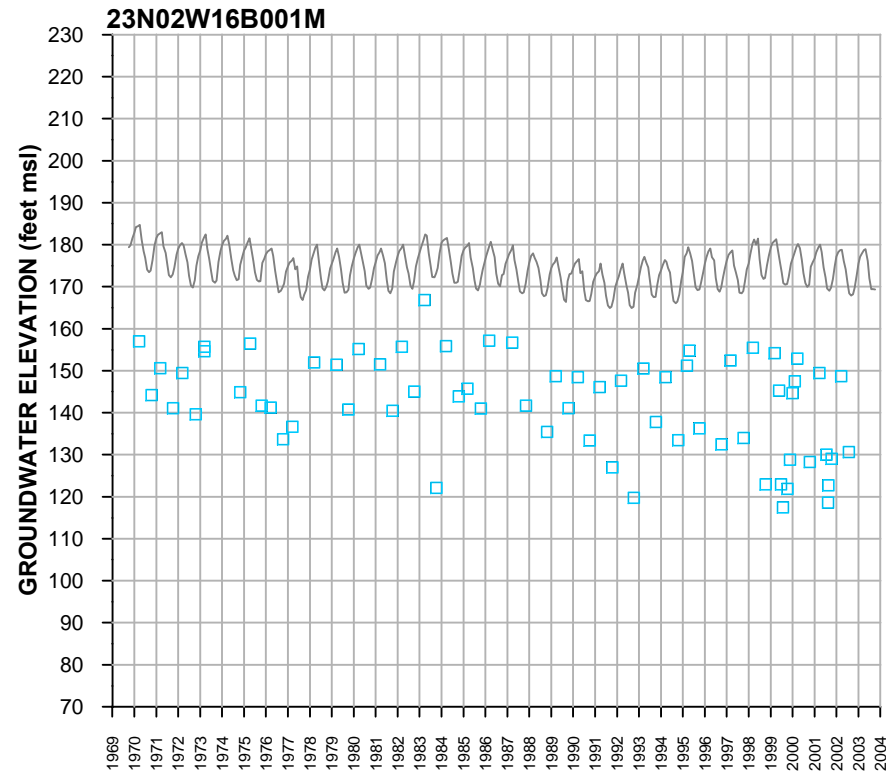

LEGEND

- MEASURED GROUNDWATER ELEVATION (feet msl)
- SIMULATED DAILY GROUNDWATER ELEVATION (feet msl)
- - - MEAN SEA LEVEL (feet msl)

FIGURE B-10 (PAGE 10 of 11)
TRANSIENT CALIBRATION HYDROGRAPHS
 DOCUMENTATION OF THE SACFEM
 GROUNDWATER FLOW MODEL
 SACRAMENTO VALLEY GROUNDWATER BASIN



ATTACHMENT D
Delta Water Quality Violations 2013



BUREAU OF RECLAMATION
 Central Valley Operation Office
 3310 El Camino Avenue, Suite 300
 Sacramento, California 95821



DEPARTMENT OF WATER RESOURCES
 Division of Operations and Maintenance
 3310 El Camino Avenue, Suite 300
 Sacramento, California 95821

MAY 24 2013

IN REPLY REFER TO:

CVO-100
 WTR-4.10

Thomas Howard
 Executive Director
 State Water Resources Control Board
 1001 I Street
 Sacramento, California 95814

Subject: April 2013 Exceedence of Salinity Objectives at Emmaton

Dear Mr. Howard:

On April 28, 2013, the Bureau of Reclamation and the Department of Water Resources (collectively the Projects) exceeded the D-1641 salinity objective at Emmaton. Project operations staff notified State Water Resource Control Board (SWRCB) staff of the exceedence by conference call on April 29, 2013, and by e-mail notification to the SWRCB. This letter provides formal notification of the exceedence and background information relevant to the circumstances.

Background information leading to exceedence conditions:

The exceedence of the 14-day running average of 0.45 EC salinity objective at Emmaton for a Sacramento Valley Dry Year type was caused by the interaction of two conditions: low river flows on the lower Sacramento River system culminating at Freeport, and increasing tides during the period of April 21, 2013, through April 25, 2013. Tidal trends and fluctuations are conditions generally anticipated by Project operators as part of salinity objective compliance; however, the low flow conditions on the lower Sacramento River system in late April 2013 was not anticipated by Project operators and is the main factor of the exceedences that have occurred at Emmaton.

Precipitation patterns for water year 2013 have been a scenario of extremes. The months of November and December produced significant rainfall and project reservoir storage correspondingly increased without any significant flood control releases from major project reservoirs. The calendar year precipitation, however, has been dismal. The accumulation of rainfall since January 1 for the long record of the Northern Sierra 8-Station Precipitation Index is

Subject: April 2013 Exceedence of Salinity Objectives at Emmaton

2

approximately 8.8 inches. Currently, this value represents the driest calendar year period in the long precipitation record—even drier than the very dry single years of 1977 and 1924. Creek and small stream flows that enter the Sacramento River system below major reservoirs are running at historically very low levels in response to this long, dry precipitation period. (Attach 8SI plot)

Historically, the initial diversion for rice cultivation and ponding has generally occurred from late April to early May, depending on farmer cultivation and preparation practices and soil moisture conditions, to allow farmers to prepare their fields. Generally, project operators have observed this diversion to rice fields occur over several weeks from late April to early May, and have monitored river conditions and increased reservoir releases as rice cultivation diversion rates increased. It now appears that in 2013, due to the very dry hydrologic conditions since the first of the year, a very large portion of rice fields were cultivated and ready to begin their initial field flooding on a simultaneous schedule during the third week of April. This diversion to rice cultivation, although expected to occur, was unanticipated by Project operators for the sheer size and magnitude of simultaneous initial diversion for rice cultivation that actually occurred valley-wide.

Project operators responded to the increasing diversion rates during this period; by increasing reservoir releases in an attempt to catch up to the lower Sacramento River flow conditions. Figures 1 and 2 illustrate the Projects' reservoir release response to flow conditions in the lower Sacramento River during this period of unprecedented diversions. The first illustration shows Keswick's releases in response to the flow pattern at the Wilkins Slough river gage location. This section of the Sacramento River Basin is controlled exclusively with Shasta/Keswick reservoir releases with an approximate lagged travel time of 2.5 days between Keswick and Wilkins Slough. The second illustration indicates the reservoir releases in response to the flow pattern at the Verona river gage location. Verona flow is influenced by reservoir releases from Keswick Reservoir as well as Oroville Reservoir's releases to the Feather River. The approximate lagged travel time from Keswick is 3.5 days and just over one day from Oroville. Both illustrations show the dramatic increases from project reservoirs in response to low flow conditions observed along the lower Sacramento River. The dramatic increase in overall depletion rates experienced over a period of about ten days was simply not anticipated by project operators and is extreme from a historical perspective. Reservoir release rates of 11,000 cfs from Keswick Reservoir and 5,250 from Oroville Reservoir are more typical of late May than late April even in a dry condition. Folsom Reservoir releases were increased from 1,000 cfs to 1,250 cfs on April 25, 2013, to also contribute to lower Sacramento River flows.

The result of this unusual condition and timing is that Freeport flows entering the Delta were very low for a period of a week to ten days. (See Operational Report). At the same time, pulse flows were entering the Delta from the San Joaquin River at Vernalis as part of the annual pulse flow management from the San Joaquin River Basin. Due to the low flow conditions at Freeport, salinity conditions in the vicinity of Collinsville and Emmaton along the extreme lower Sacramento River and western Delta increased dramatically as tidal conditions increased. (See Operational Report). Project operators responded to the changing conditions by reducing scheduled exports that were anticipated to be near a 1:1 ratio with Vernalis flow in order to

Subject: April 2013 Exceedence of Salinity Objectives at Emmaton

3

maintain Delta outflow conditions necessary to meet X2 objectives at Collinsville. Without adequate flows at Freeport to repel salinity conditions in the lower Sacramento River, salinity levels near Emmaton inevitably exceeded the dry year objective of the maximum 14-day running average of mean at 0.45 salinity. Project reservoir releases stabilized Freeport flows at greater than 10,000 cfs beginning April 28, 2013, and averaged above this rate until compliance of the 14-day 0.45 EC objective at Emmaton was re-established on May 19.

Challenges facing project operations for the remainder of year:

By D-1641 criteria, water year 2013 is classified as a "Dry" year as published in the last Bulletin 120 update for May 1st hydrologic conditions. As previously mentioned, water year 2013 has been a year of extremes with generally wet conditions in November and December and retention of storage in upstream reservoirs, followed by extreme and possibly record dry precipitation conditions since January 1. This pattern of hydrologic conditions will very likely bring challenges for the remainder of this water year. Reservoir storage in Shasta and Oroville is in reasonably good shape, but will be relied upon heavily under adverse hydrologic conditions to balance the goals of Sacramento Valley diversion/depletion, Delta objectives, water supply delivery, and coldwater management. Folsom Reservoir management will be challenged by the overall availability of water and limited coldwater availability. The hydrologic conditions of 2013 and the early advent of significant depletion rates in the Sacramento Valley may indicate that historic high levels of Sacramento Valley depletions are likely during this year's irrigation season. (Projecting seasonal Sacramento Valley depletions, as compared to projecting full natural river flows in Bulletin 120, could be a difficult extrapolation from historic values, and uncertainty in depletion values is always a challenge to project operations.)

If you have any questions or would like more information regarding this notification, please contact Mr. Paul Fujitani of Reclamation at 916-979-2197 or Mr. John Leahigh at 916-574-2722.

Sincerely,



Ronald Milligan, Operations Manager
Central Valley Operations Office
U.S. Bureau of Reclamation



David H. Roose, Chief
SWP Operations Control Office
Department of Water Resources

Attachment -2

cc: See next page.

Subject: April 2013 Exceedence of Salinity Objectives at Emmaton

4

<p>cc: Mr. John Herrick, Esq. South Delta Water Agency 4255 Pacific Avenue, Suite 2 Stockton, California 95207</p>	<p>Clifford W. Schulz Kronick, Moskovitz, Tiedemann & Girard 400 Capitol Mall, Suite 2700 Sacramento, California 95814</p>
<p>Mr. Craig M. Wilson, Delta Watermaster State Water Resources Control Board 1001 I Street Sacramento, California 95812</p>	<p>Carl Wilcox California Department of Fish and Wildlife 1416 9th Street Sacramento, California 95814</p>
<p>Ms. Christine Rico Office of the Delta Watermaster State Water Resources Control Board 1001 I Street Sacramento, California 95812</p>	<p>Tim O'Laughlin O'Laughlin and Paris LLP 117 Meyers Street, Suite 110 Chico, California 95928</p>
<p>Ms. Amy L. Aufdemberge Assistant Regional Solicitor Room B-1712 2800 Cottage Way Sacramento, California 95825</p>	<p>Jon D. Rubin San Luis-Delta Mendota Water Authority 1415 L Street, Suite 800 Sacramento, California 95814</p>
<p>Mr. Dante John Nomellini, Esq. Nomellini, Grilli and McDaniel Post Office Box 1461 Stockton, California 95201</p>	<p>Daniel Sodergren, City Attorney City of Tracy 333 Civic Center Plaza Tracy, California 95376</p>
<p>Mr. Carl P. A. Nelson Bold, Polisner, Maddew, Nelson and Judson 500 Ygnacio Valley Road, Suite 325 Walnut Creek, California 94596-3840</p>	<p>Patricia D. Fernandez Division of Water Rights 1001 I Street, 14th Floor Sacramento, California 95814</p>
<p>Thomas J. Shephard, Sr. Post Office Box 20 Stockton, California 95201</p>	<p>Carolee Krieger 808 Romero Canyon Road Santa Barbara, California 93108</p>
<p>Michael Jackson Post Office Box 207 429 West Main Street Quincy, California 95971 (w/encl to each)</p>	

FIGURE 1

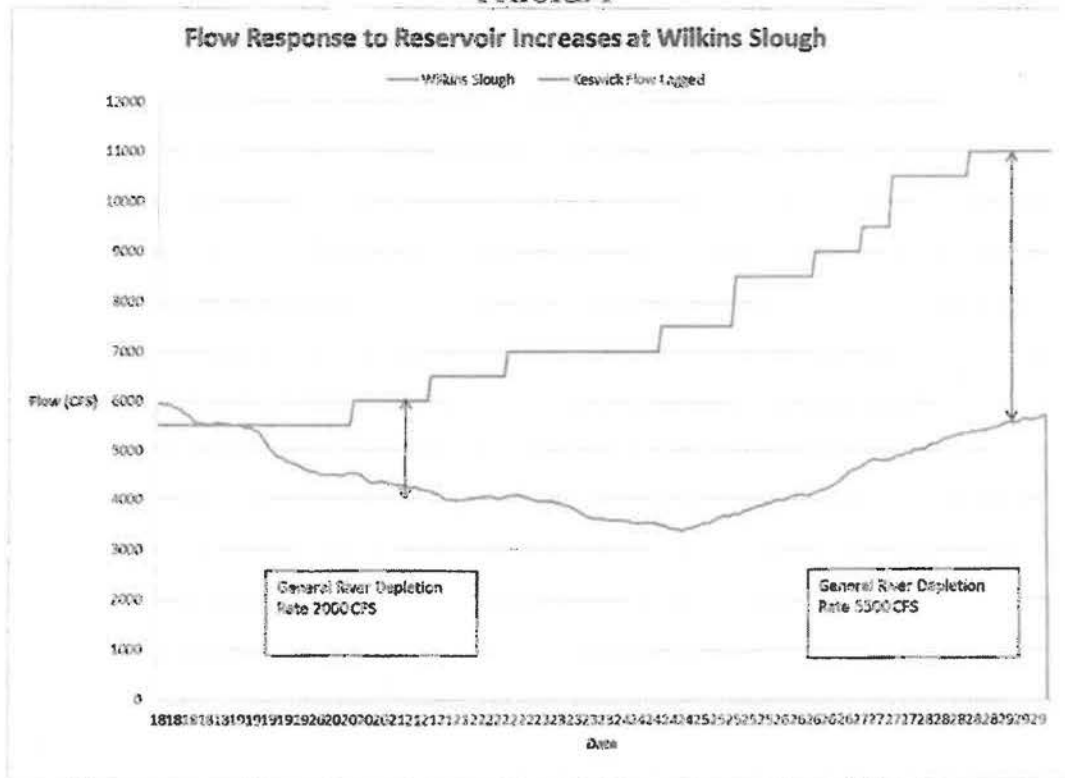
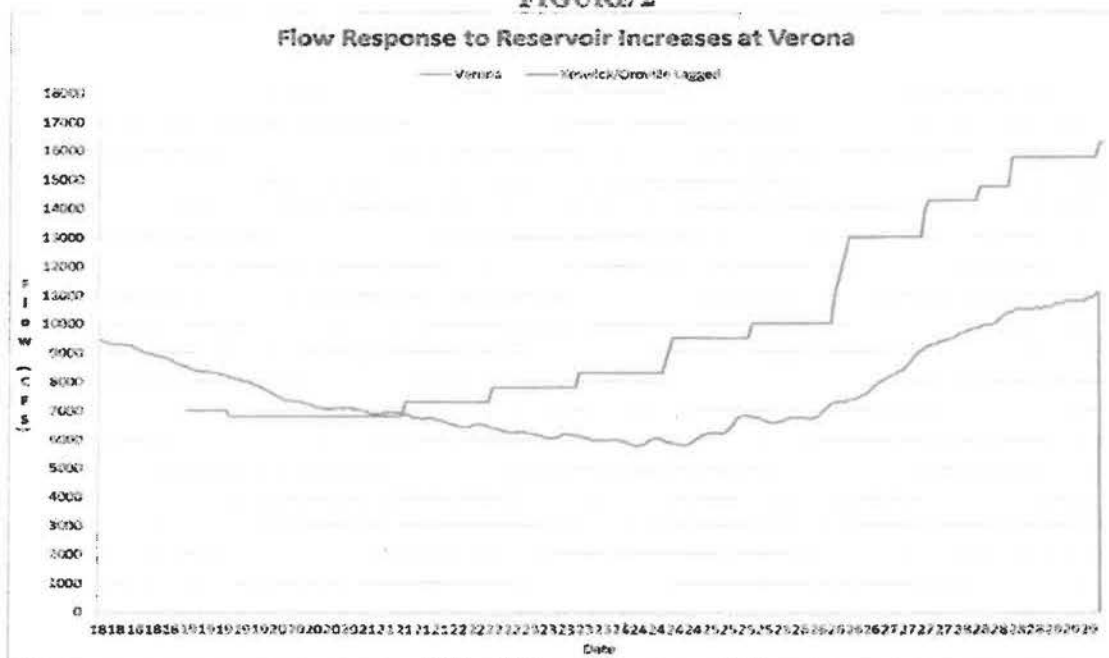
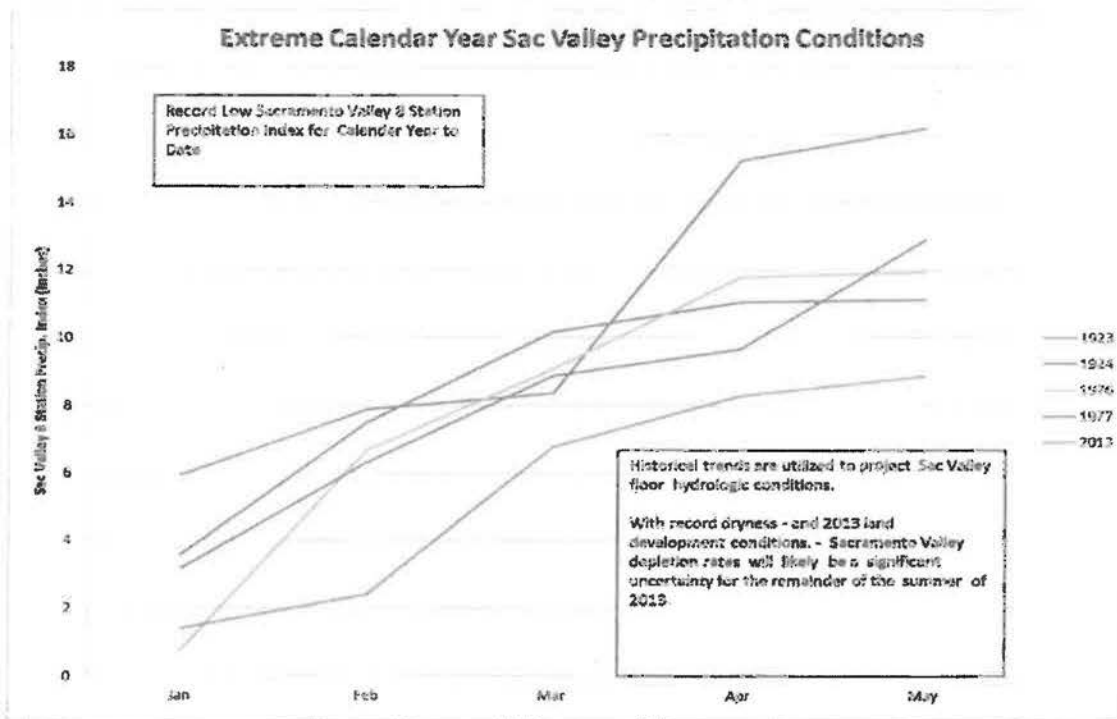
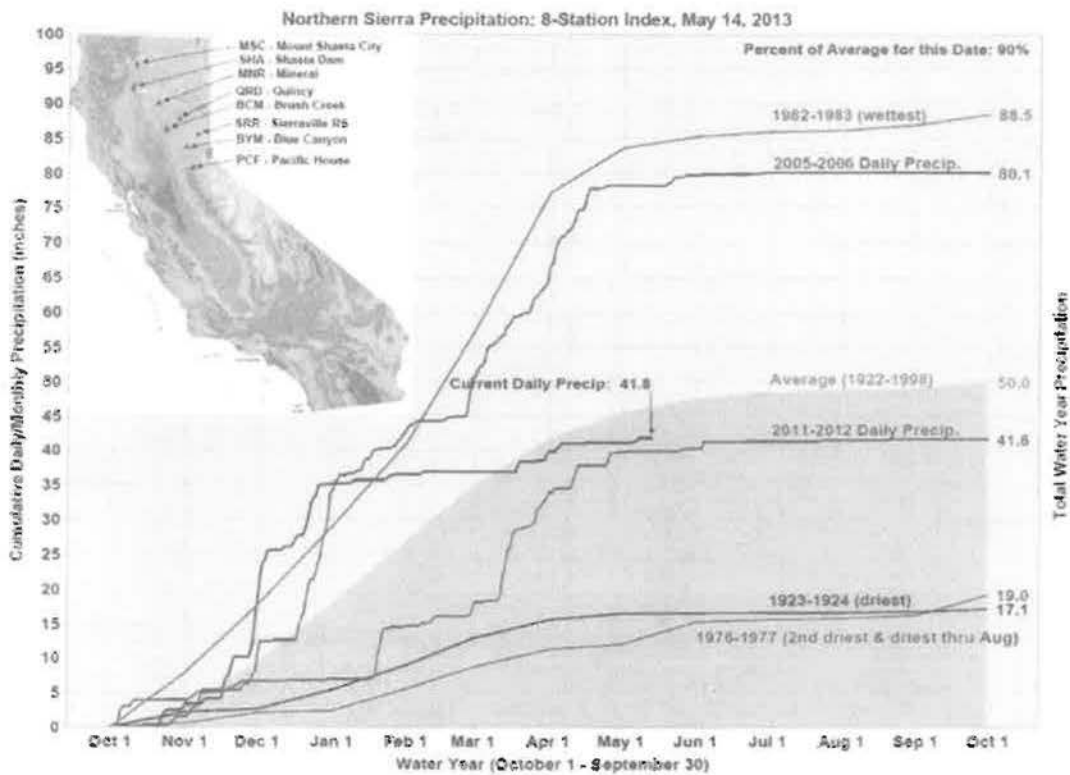

FIGURE 2



8SRI PLOT



State of California - Department of Water Resources - Division of Operations & Maintenance - Operations Control Office

Compliance Standards

for the Sacramento - San Joaquin Delta and Suisun Marsh
 Sunday, May 19, 2013

Criteria	Standard	Status
Flow/Operational		
% of inflow diverted	35 %	11 %
Habitat Protection, X2 / Flow		
* 20 days as carryover from April	1 days at Chipps Island 31 days at Collinsville	3 days 19 days
Water Quality		
Days @ CCWD PP#1 w/ chlorides <= 150 mg/l	155 days	139 days
Export Areas for SWP, CVP, CCWD, et al	<= 250 mg/l Cl	42 mg/l
14dm EC at Emmaton	<= 0.45 mS/cm	0.44 mS/cm
14dm EC at Jersey Point	<= 0.45 mS/cm	0.34 mS/cm
Maximum 30 day running average of mean daily EC at:		
Vernalis	<=0.7 mS/cm	0.3 mS/cm
Brandt Bridge	<= 0.7 mS/cm	0.3 mS/cm
Old River Near Tracy	<=0.7 mS/cm	0.4 mS/cm
Old River Near Middle River	<=0.7 mS/cm	mS/cm
SUISUN MARSH:		
Suisun Marsh Salinity Control Gates :	1 Open / 0 Closed / 2 Full Tide Open	
Flashboard Status :	In	
Boat Lock Status :	Open	

California Hydrologic Conditions: (California Cooperative Snow Surveys Forecast, May 1, 2013)

Previous Month's Index (PRI) for April: 2.023 MAF

Water Year Type: Dry

Sacramento valley water year type index (40/30/30) @ 50%: 5.8 MAF (Dry)

San Joaquin valley water year type index (60/20/20) @ 75%: 1.6 MAF (Critical)

Electrical Conductivity (EC) in millisiemens per Centimeter.
 Chlorides (Cl) in milligrams per liter
 mht - mean high tides
 md - mean daily
 14 dn - fourteen day running mean
 28 dn - twenty-eight day running mean
 NR - No Record
 NC - Average not computed due to insufficient data.
 BR - Below Rating
 e - estimated value

Montezuma Slough Gate Operation:
 Number of gates operating at either Open, Closed, or Full Tide Open
 Flashboard Status : In, Out, or Modified In
 Boat Lock Status : Open or Closed

Coordinated Operation Agreement Delta Status:
 e = excess Delta conditions
 b = balanced Delta cond. w/ no storage withdrawal
 s = balanced Delta cond. w/ storage withdrawal
 Excess Delta conditions with restrictions:
 f = fish concerns
 r = E/I ratio concerns

* NDOI, Rio Vista & Vernalis Flows:
 - Monthly average is progressive daily mean.
 - 7 day average is progressive daily mean for the first six days of the month.

State of California - Department of Water Resources - Division of Operations & Maintenance - Operations Control Office

Delta Water Quality Conditions

Date	Antioch Tides		Net Delta Outflow Index cfs	Martinez mdEC	Port Chicago		Mallard mdEC	Chippis Island		Collinsville	
	High	Half			mdEC	14dm		mdEC	14dm	mdEC	14dm
04/20/2013	4.93	3.50	8,211	18.80	11.88	7.15	4.52	3.99	1.84	1.85	0.55
04/21/2013	5.12	3.57	7,471	21.29	13.71	7.53	6.22	5.68	1.90	2.35	0.68
04/22/2013	5.33	3.66	7,059	22.73	15.38	8.08	6.75	6.22	2.20	3.03	0.85
04/23/2013	5.73	3.88	6,849	24.39	15.82	8.80	7.88	7.37	2.65	4.18	1.12
04/24/2013	6.07	4.19	6,605	25.78	18.18	9.65	9.84	9.43	3.23	5.31	1.47
04/25/2013	6.47	4.25	7,038	26.40	18.77	10.49	10.63	10.27	3.86	6.13	1.88
04/26/2013	6.32	4.08	7,896	25.52	17.32	11.21	9.19	8.74	4.38	5.33	2.22
04/27/2013	6.31	4.02	9,030	24.92	16.50	11.84	8.76	8.29	4.86	4.95	2.54
04/28/2013	6.36	4.08	10,396	24.58	15.95	12.44	8.30	7.81	5.31	4.65	2.84
04/29/2013	6.40	4.24	10,578	24.44	14.82	12.96	8.21	7.72	5.75	4.38	3.11
04/30/2013	6.24	4.15	10,798	23.98	13.59	13.56	7.92	7.42	6.21	4.37	3.40
05/01/2013	5.94	3.99	11,146	22.44	11.37	14.10	8.67	6.13	6.60	3.97	3.68
05/02/2013	5.30	3.75	11,614	21.84	12.15	14.52	6.15	5.91	6.93	2.99	3.85
05/03/2013	5.51	3.32	10,835	21.60	12.21	14.73	6.64	6.10	7.20	3.02	4.02
05/04/2013	6.13	4.17	9,608	22.78	12.34	14.84	7.67	7.16	7.42	3.97	4.19
05/05/2013	6.32	4.48	9,485	25.15	12.95	14.79	9.37	3.93	7.66	5.28	4.40
05/06/2013	6.15	4.19	9,388	24.14	11.38	14.50	8.18	7.89	7.76	4.51	4.50
05/07/2013	6.06	4.10	9,350	23.80	11.10	14.17	8.04	7.54	7.77	4.44	4.52
05/08/2013	6.01	4.07	9,129	24.07	10.98	13.65	8.21	7.71	7.65	4.37	4.46
05/09/2013	6.05	4.08	9,895	23.57	9.40	12.98	7.95	7.45	7.45	4.07	4.31
05/10/2013	6.06	4.08	10,994	22.85	8.69	12.37	7.50	6.98	7.32	3.91	4.21
05/11/2013	5.04	4.03	11,743	21.76	7.75	11.76	6.83	5.09	7.17	3.39	4.10
05/12/2013	5.98	4.06	11,661	20.78	7.95	11.23	6.40	5.87	7.03	3.28	4.00
05/13/2013	5.94	4.12	11,402	21.10	7.48	10.70	6.19	5.65	6.88	3.12	3.91
05/14/2013	5.80	4.16	11,153	21.37	6.97	10.23	6.22	5.88	6.76	2.89	3.80
05/15/2013	5.72	4.15	10,114	21.13	5.60	9.82	6.14	5.60	6.72	2.74	3.71
05/16/2013	5.26	4.02	9,550	21.54	2.97	9.16	5.75	5.21	6.89	2.87	3.70
05/17/2013	5.18	3.95	8,967	21.04	2.33	8.46	5.39	4.85	6.60	1.99	3.63
05/18/2013	5.07	3.63	9,399	18.61	2.09	7.69	4.55	4.02	6.38	1.69	3.47
05/19/2013	5.27	3.48	9,727	18.03	1.99	6.91	4.14	3.62	6.00	1.52	3.20

Antioch Tides measured in feet above mean sea level.
Net Delta Outflow Index calculated from equation as specified in D-1541, revised June 1995.
Chippis Island EC calculated from measurements recorded at Mallard Slough.
Electrical Conductivity (EC) units: milliSiemens per Centimeter
md : mean daily
14dm : fourteen day running mean
NR : No Record
NC : Average not computed due to insufficient data
BR : Below Rating
e - estimated value

State of California - Department of Water Resources - Division of Operations & Maintenance - Operations Control Office

Delta Water Quality Conditions

Date	Antioch		Jersey Point		Emmerton		Cache Slough	Good Year Slough	Sunrise Club	Volanti Slough	Belden Landing	Collinsville	
	mdEC	14mdEC	mdEC	14mdEC	mdEC	14mdEC	mdEC	mhtEC	mhtEC	mhtEC	mhtEC	mhtEC	
04/20/2013	0.39	0.42	0.23	0.25	0.20	0.20	0.39	5.83	5.06	5.62	5.55	2.04	
04/21/2013	0.61	0.42	0.24	0.25	0.22	0.20	0.40	5.92	5.40	6.19	5.60	3.56	
04/22/2013	0.87	0.44	0.24	0.25	0.25	0.20	0.42	6.13	5.97	6.77	5.93	4.39	
04/23/2013	1.16	0.49	0.25	0.25	0.29	0.21	0.42	6.94	7.31	8.39	7.40	5.37	
04/24/2013	1.93	0.60	0.30	0.25	0.71	0.25	0.42	8.71	8.59	10.03	9.00	6.92	
04/25/2013	2.36	0.74	0.36	0.26	1.28	0.32	0.43	9.73	8.79	10.32	9.24	7.42	
04/26/2013	1.91	0.85	0.33	0.26	1.06	0.39	0.43	10.74	9.36	10.77	9.23	6.54	
04/27/2013	1.87	0.95	0.34	0.27	1.00	0.44	0.42	11.60	9.71	11.16	9.59	5.86	
04/28/2013	1.93	1.05	0.35	0.27	0.89	0.49	0.43	11.74	9.83	10.73	10.02	5.61	
04/29/2013	2.04	1.17	0.38	0.28	0.75	0.53	0.45	11.84	10.00	11.33	10.34	5.73	
04/30/2013	1.90	1.28	0.37	0.29	0.64	0.56	0.46	11.91	9.92	11.63	10.50	5.40	
05/01/2013	1.33	1.35	0.35	0.30	0.35	0.57	0.51	11.90	9.76	11.44	10.86	4.69	
05/02/2013	1.28	1.42	0.32	0.31	0.35	0.58	0.46	11.85	9.95	11.16	10.86	3.35	
05/03/2013	1.29	1.49	0.33	0.31	0.38	0.60	0.46	11.87	9.85	11.30	9.99	4.36	
05/04/2013	1.55	1.57	0.36	0.32	0.44	0.61	0.48	11.74	10.13	10.74	9.79	5.88	
05/05/2013	2.21	1.89	0.44	0.34	0.76	0.65	0.42	11.59	9.35	10.94	9.73	6.92	
05/06/2013	1.87	1.76	0.39	0.35	0.67	0.68	0.42	11.57	9.68	10.53	8.64	5.54	
05/07/2013	1.71	1.80	0.37	0.36	0.62	0.71	0.43	11.61	9.25	9.83	7.57	5.72	
05/08/2013	1.86	1.73	0.36	0.36	0.63	0.70	0.45	11.84	8.67	9.42	7.11	5.77	
05/09/2013	1.63	1.73	0.36	0.36	0.61	0.65	0.48	11.79	8.12	9.21	6.63	5.27	
05/10/2013	1.48	1.70	0.35	0.36	0.57	0.62	0.50	11.99	7.76	8.60	8.49	5.24	
05/11/2013	1.32	1.65	0.34	0.36	0.46	0.58	0.48	12.11	7.49	8.22	6.05	4.24	
05/12/2013	1.32	1.61	0.34	0.36	0.41	0.54	0.45	11.82	7.10	7.63	5.50	4.49	
05/13/2013	1.18	1.55	0.34	0.36	0.37	0.52	0.45	11.36	6.59	7.07	4.94	3.93	
05/14/2013	1.12	1.50	0.34	0.36	0.34	0.50	0.43	11.33	6.13	6.45	4.24	4.30	
05/15/2013	1.11	1.48	0.33	0.35	0.37	0.50	0.42	11.16	5.72	5.97	3.88	3.56	
05/16/2013	1.03	1.46	0.32	0.35	0.32	0.50	0.40	10.60	5.18	5.67	3.68		
05/17/2013	0.91	1.44	0.31	0.35	0.29	0.49		NR	10.25	5.10	5.62	3.53	3.14
05/18/2013	0.74	1.36	0.30	0.35	0.25	0.48		NR	10.12	5.04	5.56	3.31	2.43
05/19/2013	0.70	1.27	0.29	0.34	0.23	0.44		NR	9.95	4.98	5.51	2.97	2.33

Electrical Conductivity (EC) units: milliSiemens per Centimeter
 Chloride (Cl) units: milligrams per liter
 mht : mean high tides
 md : mean daily
 NR : No Record
 NC : Average not computed due to insufficient data
 BR : Below Rating
 e : estimated value

State of California - Department of Water Resources - Division of Operations & Maintenance - Operations Control Office

Delta Water Quality Conditions

Date	Bathel Island mdEC	Farrar Park mdEC	Holland Tract mdEC	Bacon Island mdEC	Contra Costa mdEC	Clifton Court mdEC	Tracy Pumping Plant mdEC	Antioch mdCl	Bacon Island mdCl	Contra Costa mdCl	Delta Status
04/20/2013	0.25	0.29	0.26	0.27	0.34	0.57	0.75	54	33	37	f
04/21/2013	0.25	0.29	0.25	0.27	0.32	0.51	0.68	124	32	36	f
04/22/2013	0.24	0.29	0.25	0.27	0.33	0.46	0.60	206	32	37	f
04/23/2013	0.24	0.29	0.25	0.27	0.33	0.43	0.50	288	31	37	f
04/24/2013	0.25	0.26	0.25	0.27	0.32	0.40	0.49	545	31	37	f
04/25/2013	0.26	0.27	0.25	0.26	0.32	0.38	0.42	683	31	36	s
04/26/2013	0.26	0.29	0.26	0.27	0.31	0.35	0.43	537	32	36	s
04/27/2013	0.25	0.29	0.26	0.26	0.32	0.32	0.40	524	34	36	s
04/28/2013	0.26	0.29	0.26	0.28	0.32	0.32	0.35	544	35	36	s
04/29/2013	0.26	0.30	0.26	0.28	0.29	0.31	0.32	681	35	36	s
04/30/2013	0.28	0.30	0.26	0.28	0.31	0.34	0.33	535	34	36	s
05/01/2013	0.27	0.29	0.26	0.27	0.30	0.32	0.33	352	32	36	s
05/02/2013	0.28	0.29	0.21	0.27	0.31	0.33	0.32	337	32	34	s
05/03/2013	0.28	0.29	0.23	0.27	0.31	0.33	0.31	341	32	35	s
05/04/2013	0.28	0.30	0.27	0.27	0.30	0.32	0.31	424	32	35 e	s
05/05/2013	0.29	0.31	0.28	0.28	0.29	0.30	0.28	635	34	35 e	s
05/06/2013	0.29	0.31	0.28	0.28	0.29	0.25	0.28	525	35	33	s
05/07/2013	0.29	0.32	0.28	0.29	0.29	0.24	NR	475	37	33	s
05/08/2013	0.30	0.33	0.29	0.29	0.23	0.24	NR	458	38	33	s
05/09/2013	0.30	0.33	0.29	0.30	0.30	0.25	NR	448	40	34	s
05/10/2013	0.31	0.34	0.30	0.30	0.30	0.26	NR	400	41	35	s
05/11/2013	0.31	0.33	0.30	0.31	0.29	0.28	NR	351	42	35 e	s
05/12/2013	0.31	0.34	0.30	0.31	0.31	0.29	NR	351	43	35 e	s
05/13/2013	0.31	0.33	0.31	0.32	0.32	0.31	NR	307	44	37	s
05/14/2013	0.31	0.33	0.31	0.32	0.32	0.30	NR	288	45	39	s
05/15/2013	0.31	0.34	0.31	0.32	0.32	0.32	NR	283	45	36	s
05/16/2013	0.31	0.34	0.31	0.32	NR	0.34	NR	257	45	40	s
05/17/2013	0.31	0.34	0.31	0.32	NR	0.35	NR	220	46	42	s
05/18/2013	0.31	0.34	0.31	0.33	NR	0.36	NR	166	47	42 e	s
05/19/2013	0.31	0.34	0.31	0.33	NR	0.39	NR	151	47	42 e	s

Electrical Conductivity (EC) units: milliSiemens per Centimeter
 Chloride (Cl) units: milligrams per liter
 rrd : mean daily
 NR : No Record
 NC : Average not computed due to insufficient data
 BR : Below Rating
 e : estimated value
 Antioch and Bacon Island mdCl are calculated from the respective mdEC values.

Coordinated Operation Agreement Delta Status:
 c = excess Delta conditions
 b = balanced Delta cond. w/ no storage withdrawal
 s = balanced Delta cond. w/ storage withdrawal
 Excess Delta conditions with restrictions:
 f = fish concerns
 r = R/r ratio concerns

State of California - Department of Water Resources - Division of Operations & Maintenance - Operations Control Office

Delta Water Quality Conditions

South Delta Stations

Date	Vernalis		Brandt Bridge		Old River Near Tracy		Old River Near Middle River	
	md EC	30 day avg	md EC	30 day avg	md EC	30 day avg	md EC	30 day avg
04/20/2013	0.39	0.79	0.52	0.88	0.90	1.10	0.40	0.87
04/21/2013	0.30	0.77	0.41	0.86	0.76	1.09	0.43	0.85
04/22/2013	0.30	0.75	0.42	0.84	0.64	1.08	0.33	0.84
04/23/2013	0.27	0.72	0.32	0.82	0.62	1.07	0.31	0.81
04/24/2013	0.25	0.70	0.30	0.80	0.47	1.05	0.26	0.79
04/25/2013	0.24	0.68	0.24	0.78	0.41	1.02	0.22	0.77
04/26/2013	0.24	0.65	0.22	0.76	0.34	1.00	0.21	0.74
04/27/2013	0.23	0.62	0.21	0.73	0.38	0.97	0.21	0.72
04/28/2013	0.23	0.60	0.21	0.71	0.38	0.94	0.21	0.69
04/29/2013	0.22	0.58	0.21	0.68	0.37	0.91	0.20	0.66
04/30/2013	0.22	0.56	0.20	0.66	0.35	0.88	0.20	0.64
05/01/2013	0.21	0.54	0.20	0.64	0.32	0.85	0.20	0.61
05/02/2013	0.21	0.52	0.20	0.61	0.36	0.82	0.19	0.59
05/03/2013	0.20	0.50	0.20	0.59	0.36	0.80	0.20	0.57
05/04/2013	0.19	0.47	0.19	0.57	0.31	0.77	0.18	0.55
05/05/2013	0.18	0.45	0.18	0.55	0.27	0.74	0.17	0.52
05/06/2013	0.19	0.43	0.17	0.52	0.25	0.72	0.17	0.50
05/07/2013	0.20	0.41	0.18	0.50	0.28	0.69	0.18	0.48
05/08/2013	0.20	0.39	0.20	0.48	0.31	0.67	0.20	0.45
05/09/2013	0.22	0.37	0.20	0.45	0.30	0.64	0.21	0.43
05/10/2013	0.22	0.35	0.22	0.43	0.29	0.62	NR	NC
05/11/2013	0.21	0.33	0.23	0.41	0.29	0.59	NR	NC
05/12/2013	0.21	0.31	0.22	0.38	0.29	0.56	NR	NC
05/13/2013	0.22	0.29	0.22	0.36	0.30	0.53	0.23	NC
05/14/2013	0.26	0.28	0.24	0.34	0.30	0.50	0.25	NC
05/15/2013	0.33	0.27	0.27	0.32	0.31	0.48	0.29	NC
05/16/2013	0.38	0.26	0.32	0.30	0.36	0.45	0.37	NC
05/17/2013	0.40	0.26	0.37	0.29	0.43	0.43	0.44	NC
05/18/2013	0.44	0.26	0.44	0.27	0.47	0.42	0.47	NC
05/19/2013	0.48	0.26	0.47	0.27	0.54	0.40	0.51	NC

Electrical Conductivity (EC) units: millisiemens per Centimeter
 md : mean daily
 NR : No Record
 NC : Average not computed due to insufficient data
 BR : Below Rating
 e : estimated value

State of California - Department of Water Resources - Division of Operations & Maintenance - Operations Control Office

Delta Hydrology Conditions

Date	Sacramento River at Frearport + SRWTP cfs	Yolo Bypass cfs	East Side Streams cfs	San Joaquin River at Vernalis cfs	Rainfall inches	Clifton Court Forebay Intake cfs	Tracy Pumping Plant cfs	CCWD Pumping Plants cfs	Barker Slough Pumping Plant cfs	BBID Diversion cfs
4/20/2013	8,441	395	591	2,334	0.00	1,193	807	25	56	0
4/21/2013	7,858	398	548	2,545	0.00	1,494	810	25	62	0
4/22/2013	7,845 e	410	519	2,678	0.00	1,694	810	25	62	200
4/23/2013	7,194	439	529	2,935	0.00	1,690	813	25	48	73
4/24/2013	6,360	495	559	3,414	0.00	1,695	821	26	72	72
4/25/2013	7,006	530	570	3,582	0.00	990	817	25	70	57
4/26/2013	8,078	529	542	3,675	0.00	991	815	25	65	53
4/27/2013	9,423	585	502	3,765	0.00	995	814	24	78	66
4/28/2013	10,870	594	509	3,893	0.00	963	815	24	77	0
4/29/2013	11,478	602	512	4,130	0.00	2,421	915	26	83	66
4/30/2013	12,147	616	500	4,064	0.00	2,998	817	27	83	0
5/1/2013	12,415	623	479	3,954	0.00	3,193	814	152	88	66
5/2/2013	11,495	629	463	3,952	0.00	494	3,155	176	94	63
5/3/2013	10,056	623	466	4,043	0.00	494	3,082	226	117	67
5/4/2013	9,028	660	478	4,176	0.00	1,492	1,353	240	96	0
5/5/2013	8,414	665	456	4,105	0.00	1,490	937	245	94	0
5/8/2013	8,445	648	445	3,970	0.00	993	982	245	91	159
5/7/2013	8,390	616	456	3,838	0.00	793	980	243	84	91
5/6/2013	9,212	557	479	3,689	0.00	792	979	243	84	77
5/9/2013	10,884	510	484	3,581	0.00	793	978	257	84	70
5/10/2013	11,824	486	468	3,549	0.00	999	978	261	98	72
5/11/2013	12,068	450	478	3,509	0.00	993	983	258	101	0
5/12/2013	11,480	448	479	3,439	0.00	993	982	260	109	0
5/13/2013	11,425	500	451	3,370	0.00	993	980	268	110	206
5/14/2013	10,886	553	416	2,828	0.00	993	980	252	99	76
5/15/2013	10,928	603	400	2,090	0.00	992	979	236	97	86
5/16/2013	10,409	579	410	1,978	0.00	993	863	207	92	84
5/17/2013	11,073	605	445	1,521	0.00	688	811	190	103	65
5/18/2013	11,534	643	439	1,423	0.00	689	808	185	112	0
5/19/2013	11,854	618	418	1,309	0.00	699	808	202	103	0

SRWTP : Sacramento Regional Water Treatment Plant effluent.

Yolo Bypass : combined measurements of Cache Creek at Rumsey and Fremont Weir.

East Side Streams : combined stream flows of Cosumnes River at Michigan Bar, Mokelumne River at Woodbridge, miscellaneous streams estimated from Dry Creek at Galt (discontinued since Dec. 1997), and Calaveras River based on releases from New Hogan Dam.

Rainfall : incremental daily precipitation measured at Stockton Fire Station 44.

CCWD Pumping Plants : combined pumping at the Old River, Rock Slough and Middle River Plants.

State of California - Department of Water Resources - Division of Operations & Maintenance - Operations Control Office

Delta Hydrology Conditions

Date	Banks Pumping Plant cfs	Delta Gross Channel Depletions cfs	Rio Vista Flow cfs	QWEST cfs	Net Delta Outflow Index cfs	Percent of Inflow Diverted		Delta Status
						3 day	14 day	
4/20/2013	1,161	1,900	7,029	1,372	8,211	13.3%	10.4%	f
4/21/2013	1,504	1,900	6,352	1,313	7,471	16.4%	12.6%	f
4/22/2013	1,504	1,900	5,950	1,404	7,059	18.7%	14.2%	f
4/23/2013	1,779	1,900	5,677	1,353	6,849	20.5%	15.7%	f
4/24/2013	1,504	1,950	5,301	1,512	6,605	21.3%	16.7%	f
4/25/2013	810	1,950	4,635	2,609	7,038	20.0%	16.0%	s
4/26/2013	895	1,950	5,229	2,868	7,893	17.7%	14.8%	s
4/27/2013	587	1,950	6,158	3,087	9,030	14.8%	13.4%	s
4/28/2013	995	2,000	7,366	3,247	10,396	13.0%	13.7%	s
4/29/2013	1,684	2,000	8,619	2,181	10,578	15.6%	17.3%	s
4/30/2013	2,348	2,000	9,164	1,856	10,798	18.7%	22.5%	s
5/1/2013	3,279	2,000	9,758	1,616	11,146	21.3%	27.7%	s
5/2/2013	1,123	2,000	9,998	1,850	11,614	22.0%	28.2%	s
5/3/2013	1,034	2,050	9,192	1,704	10,635	21.5%	26.9%	s
5/4/2013	1,054	2,100	7,925	2,226	9,906	20.2%	23.9%	s
5/5/2013	2,095	2,100	7,070	2,646	9,485	19.1%	20.8%	s
5/6/2013	590	2,100	6,543	3,083	9,388	16.4%	16.6%	s
5/7/2013	0	2,150	6,539	3,045	9,350	14.3%	13.7%	s
5/8/2013	0	2,150	6,459	2,905	9,129	12.8%	11.9%	s
5/9/2013	138	2,200	7,099	2,835	9,695	12.5%	11.5%	s
5/10/2013	1,101	2,200	8,501	2,745	10,994	12.4%	11.8%	s
5/11/2013	1,101	2,250	9,278	2,723	11,743	12.2%	12.2%	s
5/12/2013	1,101	2,300	9,440	2,891	11,861	12.1%	12.6%	s
5/13/2013	1,101	2,300	9,928	2,746	11,402	11.7%	12.3%	s
5/14/2013	1,015	2,350	8,918	2,498	11,153	11.7%	12.2%	s
5/15/2013	1,101	2,350	8,504	1,872	10,114	12.0%	12.2%	s
5/16/2013	930	2,400	8,577	1,233	9,550	12.5%	12.4%	s
5/17/2013	732	2,450	8,167	1,095	8,987	12.2%	11.6%	s
5/18/2013	732	2,450	8,690	992	9,399	11.5%	10.8%	s
5/19/2013	732	2,500	9,114	892	9,727	10.9%	10.2%	s

Delta Gross Channel Depletions from Dayflow Table 3.
Rio Vista Flow calculated from Dayflow equation.
QWEST calculated from Dayflow equation.
Net Delta Outflow Index calculated from equation as specified in D-1641, revised June 1995.

Coordinated Operation Agreement Delta Status:

- c = excess Delta conditions
 - b = balanced Delta cond. w/ no storage withdrawal
 - s = balanced Delta cond. w/ storage withdrawal
- Excess Delta conditions with restrictions:
- f = fish concerns
 - r = E/I ratio concerns

Nomellini, Grilli McDaniel PLCs

From: Grober, Les@Waterboards [Les.Grober@waterboards.ca.gov]
Sent: Wednesday, May 29, 2013 8:40 AM
To: ngmplcs@pacbell.net
Subject: FW: USBR and DWR request re delta standards

Attachments: Milligan,R. -2013-05_SWRCB Water Right Decision 1641 Water Year Classification.pdf; CDFW concurrence with proposed changes to Delta WQ standards requested by DWR and Reclamation; NMFS support for change petition to D-1641; FWS concurrence with proposed changes to Delta WQ standards, as requested by Reclamation and DWR; RE: NMFS support for change petition to D-1641



Milligan,R. CDFW NMFS support FWS RE: NMFS
 3-05_SWRCB Wrence with propo change petiti.ence with propoort for change

Dante,

Here is the email I sent Melinda yesterday. The last attachment is the email response from Tom.

Les

From: Grober, Les@Waterboards
Sent: Tuesday, May 28, 2013 4:35 PM
To: 'Melinda Terry (melinda@northdw.com)'
Cc: Riddle, Diane@Waterboards
Subject: USBR and DWR request re delta standards

Melinda,

It was nice chatting with you. As we discussed, attached are the following emails/letters: the USBR/DWR request, emails from three fishery agencies, and Tom Howard's 5/24 response to the emails we had received at that point from NMFS and CDFW, as we had not yet gotten a request from USBR/DWR.

I'll send you a copy of the follow-up letter from Craig Wilson, the Delta Watermaster, tomorrow.

Please call or email if you have questions.

Les

Leslie F. Grober, Assistant Deputy Director Hearings and Special Programs Branch Division
 of Water Rights State Water Resources Control Board
 1001 I Street
 Sacramento, CA 95814

Telephone: (916) 341-5428

Fax: (916) 341-5400

E-mail: lgrober@waterboards.ca.gov<mailto:lgrober@waterboards.ca.gov>



BUREAU OF RECLAMATION
 Central Valley Operation Office
 3310 El Camino Avenue, Suite 300
 Sacramento, California 95821



DEPARTMENT OF WATER RESOURCES
 Division of Operations and Maintenance
 3310 El Camino Avenue, Suite 300
 Sacramento, California 95821

MAY 24 2013

IN REPLY REFER TO:

CVO-100
 WTR-4.10

Thomas Howard
 Executive Director
 State Water Resources Control Board
 1001 I Street
 Sacramento, California 95814

Subject: State Water Resources Control Board Water Right Decision 1641 Water Year
 Classification

Dear Mr. Howard:

The Department of Water Resources (DWR) and the United States Bureau of Reclamation (Reclamation) request that the State Water Resources Control Board (SWRCB) acknowledge that the water year classification for the Sacramento Valley based on the equation provided in Attachment 1, page 188 of Revised Water Rights Decision 1641 (D-1641) does not accurately reflect the unprecedented dry conditions experienced in 2013. Instead, the hydrologic conditions experienced between January and the present are characteristic of a "Critical" water year type. The current miscategorization in water year classification is projected to affect the storage of cold water pool for fisheries purposes due to controlling D-1641 Delta objectives in the May through August period. These objectives are:

- 1) EC parameters for Sacramento River at Emmaton (Interagency Station Number D-22), San Joaquin River at Jersey Point (Interagency Station Number D-15), South Fork Mokelumne River at Terminous (Interagency Station Number C-13), and San Joaquin River at San Andreas (interagency Station Number C-4) as defined in Table 2 on page 182
- 2) Delta Outflow, as defined on Table 3 on Page 184.

Subject: SWRCB Water Right Decision 1641 Water Year Classification

2

Water year classification also affects other objectives listed in D-1641 to a lesser degree, but it is not anticipated that those objectives will significantly control Delta operations in 2013.

Summary of Relevant Facts:

D-1641 imposes water quality objectives on the Central Valley Project (CVP) and State Water Project (SWP). Several of the objectives are dependent on the water year type as determined by the May 1, Sacramento Valley Index and the San Joaquin Valley Index. Although the January through April period during 2013 was the driest on record, the November and December precipitation was sufficient to result in a Sacramento Valley classification of “Dry” for water year 2013. The “Dry” water year classification is not representative of the extreme hydrological conditions in Northern California this calendar year and the water quality objectives based on this water year type could result in significant adverse impacts to the cold water pool operations at Shasta Reservoir. In fact, Governor Brown’s recent executive order B-21-13 recognizes that, “much of California experienced record dry conditions in January through March 2013, registering historic lows on the Northern Sierra” and “record dry and warm conditions resulted in a snowpack substantially below average, with estimated May water content in the statewide snowpack being only 17 percent of average.”

The 2013 water year has been particularly challenging with double the normal precipitation in November and December and historically low values from January into May. The current Northern Sierra 8 Station Precipitation Index from January 1, 2013 through May 15 is about 8.8 inches. Without additional measurable precipitation in May, this figure will represent the driest Northern Sierra 8-Station Precipitation Index for the January through May period on record. Attachment 1 shows the accumulated 8-station precipitation values from January through May for some of the extremely dry years including 1924, 1976, and 1977. The nearly 80 percent of this year’s precipitation occurred in the first three months of the water year, and an abnormally large portion of this fell as rain rather than snow as a result of warmer than normal conditions for that time of year. This combined with critically dry conditions in the months since the first of the year has resulted in minimal snow pack in the Sierra Nevada in the critical spring months. The Northern Sierra snowpack was only about 48% of the historical April 1 value and about 17% of normal as of May 1, 2013. Creek and small stream flows that enter the Sacramento River system below major reservoirs are running at historically low levels in response to the extended dry period. DWR’s May 1, 2013 Bulletin 120 forecasts an April to July runoff 48% of normal for the Sacramento Valley. Hydrological conditions are not likely to improve and the National Oceanic and Atmospheric Administration has indicated that California is in severe to extreme drought that is likely to persist or intensify into the summer (Attachment 2).

Additionally, unusually high depletions in the Sacramento Valley are adding to the operational challenges the CVP and SWP (collectively, Projects) are facing in meeting the 2013 water year type requirements. Typically, extremely dry years with low Northern Sierra 8-Station Precipitation Index values trigger the Shasta inflow shortage criteria included in water rights settlement contracts that would reduce water supplies for the senior water rights diverters in the Sacramento Valley. Yet, this year the wetter conditions in the fall months were sufficient to require full allocations to the Sacramento Valley and Feather River settlement contractors,

Subject: SWRCB Water Right Decision 1641 Water Year Classification

3

increasing demands on Shasta and Oroville storage. Therefore, it is expected that depletions will continue to run at a high rate into the summer. DWR and Reclamation are required to make releases in order to satisfy the senior water rights of the Sacramento River and Feather River settlement contractors, and the Exchange Contractors. These contracts specify the amount of water the Projects must deliver – for the Sacramento River and Exchange Contractors, Reclamation is required to deliver 100% of the contract total in any year where the forecasted inflow to Shasta Reservoir exceeds 3.2 million acre feet (af). This target was met in 2013 – thus Reclamation is mandated to deliver 100% of the contract total, and has no discretion under the contract to reduce these deliveries.

The unusually high stream depletions (Attachment 3) were a major cause of the exceedence of the Emmaton objective that occurred in April and May. This is described in further detail in DWR and Reclamation's letter to SWRCB dated May 24, 2013. The CVP and SWP reservoir systems were in a near normal condition in January, but Reclamation and DWR have drawn heavily on the storage since then due to the extended dry period, low unregulated flow entering the system, and high depletions in the Central Valley. Reservoir releases are currently well above average for this date.

In order to meet the Dry year water quality objectives rather than the Critical objectives, DWR and Reclamation have released significant volumes of water from Oroville, Shasta, and Folsom Reservoirs. The low reservoir inflow and increased storage withdrawal is depleting the cold water pool in the reservoirs that is important to provide adequate instream fishery habitat for anadromous fish in the rivers through the summer and fall.

SWRCB Water Rights Order 90-05 requires that Reclamation operate Shasta Reservoir to meet a daily average temperature of 56 degrees Fahrenheit in the Sacramento River at a location and through periods when higher temperatures will be detrimental to the fishery. Typically, through coordination with the Sacramento River Temperature Task Group (SRTTG), the location selected is between Balls Ferry and Bend Bridge on the Sacramento River. Without recognition of the Sacramento Valley water year type actually experienced in 2013, the projected low reservoir storage and limited cold water pool this year may result in the objective occurring well upstream of Balls Ferry and Reclamation is concerned whether the 56 degree objective can be maintained at any location in the Sacramento River through the fall. The cold water pool is vital to providing adequate habitat to salmon present in the Sacramento River through the summer and into the fall for both the winter-run Chinook salmon and fall-run Chinook salmon. The SRTTG has recommended an initial temperature compliance point of Airport Road located upstream of Balls Ferry due to the limited cold water resources this year.

Due to the unprecedented hydrologic conditions discussed above including the record dry January through May period, extremely low snowpack, and unusually high Sacramento valley depletions, conditions continue to deteriorate and it is clear that meeting the dry year objectives could jeopardize the ability to meet other fisheries objectives later in the year. The reservoir storage that accumulated in the wet fall, which was originally projected to be sufficient to meet the dry year objectives, is falling rapidly due to the abnormally large valley demands and

Subject: SWRCB Water Right Decision 1641 Water Year Classification

4

Reclamation is projecting CVP September carryover storages only about 63% of average.

There is a significant difference between the volume of Delta inflow needed to achieve the Dry and Critical water quality objectives for Jersey Point and Emmaton through June 15. If Reclamation and DWR are able to begin operating to the Critical year water quality objectives in May it may be possible to achieve 100,000 to 200,000 af, of cold water benefits in the upstream reservoirs. This savings in cold water storage would improve the chances of meeting the temperature objective at Airport Road. This cold water benefit will help avoid temperature related fish losses in the Sacramento River.

The greatest benefits to the Project's reservoir storage would occur in the May to August 15 period. The compliance locations in the Western Delta and Interior Delta shown in Table 3 on Page 182 (Sacramento River at Emmaton (Interagency Station Number D-22), San Joaquin River at Jersey Point (Interagency Station Number D-15), South Fork Mokelumne River at Terminous (Interagency Station Number C-13), and San Joaquin River at San Andreas Landing (Interagency Station Number C-4) would most likely be the objectives controlling the Project operations during the May to June 15 period and changes at these locations would have the greatest impact on improving upstream storage in the immediate future. The objectives of the Delta outflow compliance location in Table 3 on page 184 often can control Project operations through the summer and operating to a critical year with respect to Delta outflow will also assist in preserving cold water pool.

Currently, DWR and Reclamation are maintaining a Net Delta Outflow well over 9,000 cubic feet per second (cfs) in order to achieve the Dry year objectives for Jersey Point and Emmaton. If the Dry classification is changed to Critical, the controlling D-1641 objective through June would be the Net Delta Outflow Index of at least 7,100 cfs in Table 3, or the export to inflow ratio of 35% in Table 3. From July through August 15, the controlling criteria for either water year classification would most likely shift among the minimum Net Delta Outflow objectives in Table 3, the salinity objectives for Jersey Point and Emmaton in Table 2, the Export to Inflow ratio of 65% in Table 3, or the Contra Costa 250 chloride objective in Table 1.

Table 2 of D-1641 requires an electrical conductivity (EC) no greater than 0.45 mmhos/cm for both Emmaton and Jersey point locations from April 1 to June 15, and 1.67 mmhos/cm for Emmaton and 1.35 mmhos/cm for Jersey Point from June 15 to August 15 under a Dry Year classification. For a Critical year these objectives are 2.78 mmhos/cm from April 1 to August 15 for Jersey Point and Emmaton. Since the X2 outflow objective of 7,100 cfs, which is not linked to the year type designation would probably control in May, and June, there would only be a gradual increase in salinity at Jersey Point and Emmaton through June that is reflective of a Critical year. Water quality at Jersey Point and Emmaton would fluctuate with the tidal and meteorological conditions potentially moving towards a 1.0 to 2.0 mmhos/cm EC range in July. Compliance with the water quality objectives at the Jersey Point and Emmaton locations typically achieves the objectives at Terminous and San Andreas Landing. This gradual increase in salinity levels would be commensurate with those experienced in years with similar hydrologic conditions as those observed in recent months.

Subject: SWRCB Water Right Decision 1641 Water Year Classification

5

Reclamation estimates that from May through August 15 a change in the water year classification from Dry to Critical in the Western Delta and Interior Delta locations in Table 2 could result in a gain of about 115,000 af, in upstream reservoir carryover storage at the end of September. Including the Delta outflow compliance in Table 3 for the same period would increase the gain in reservoir carryover storage to about 185,000 af. There could be reductions in the release from Keswick Reservoir up to about 1,000 cubic feet second in late May and June under a Critical year classification.

D-1641 requires that the number of days less than or equal to 150 mg/l chloride at Contra Costa Pumping Plant be greater than 165 days for a Dry year and 155 days for a Critical year. DWR and Reclamation do not anticipate that this objective would be a controlling criteria for the Projects under either year classification and both objectives would be met. The minimum Net Delta Outflow required from February through June (Collinsville X2 at 7,100 cfs) should be adequate to achieve the Contra Costa objective under either the Dry or Critical classification.

SWRCB recognition of the change in water year type is in the public interest. The change will provide for a water year classification reflective of the extremely dry hydrologic conditions in 2013 and allow the projects to operate in a manner that will provide the maximum benefit to critical beneficial users without unreasonably affecting other designated beneficial uses. As noted above there will be no significant impacts to agricultural or municipal uses, and the change will provide significant benefit to fisheries resources. State and federal agencies have been focused on the protection and improvement of fishery conditions in the Delta watershed, and are in the process of analyzing options for balancing project operations for the numerous different beneficial uses. Approval of the following request would result in water quality conditions in the North Delta that are consistent with the hydrology we are currently experiencing, while preserving cold water storage critical to salmon survival.

Requested Action:

Reclamation and DWR request that the SWRCB recognize the change in year classification need and act immediately. Delaying such recognition to even June 1 will significantly impair Reclamation's ability to meet cold water temperature objectives on the Sacramento River. At present, the controlling D-1641 Delta water quality objectives for the Projects that are linked to the Sacramento Valley Index are Jersey Point in Table 2, Emmaton in Table 2. In addition, Delta Outflow in Table 3, may become a controlling standard and will also impact cold water pool storage starting in the middle of June.

We believe the SWRCB may balance protection of the beneficial uses in light of the critical water year type experienced on the Sacramento River in 2013. Immediate benefits to cold water pool storage can be achieved through the Projects meeting critical water year standards for the Interior and Western Delta salinity standards in Table 2. The compliance points at issue are Sacramento River at Emmaton (Interagency Station Number D-22), San Joaquin River at Jersey

Subject: SWRCB Water Right Decision 1641 Water Year Classification

6

Point (Interagency Station Number D-15), South Fork Mokelumne River at Terminous (Interagency Station Number C-13), and San Joaquin River at San Andreas Landing (Interagency Station Number C-4).

Additional cold water pool benefits can be achieved in July through September with recognition of the critical water year type in Table 3, Water Quality Objectives for Fish and Wildlife Beneficial Uses. As noted above; Delta outflow objectives will likely control project operations in July through September, where agricultural objectives are met under a critical water year designation. A Delta outflow standard reflective of the critical water year type may produce an additional 70,000 af of cold water pool storage.

If you have any questions or would like more information regarding this notification, please contact Mr. Paul Fujitani of Reclamation at 916-979-2197 or Mr. John Leahigh at 916-574-2722.

Sincerely,



Ronald Milligan, Operations Manager
Central Valley Operations Office
U.S. Bureau of Reclamation



David H. Roose, Chief
SWP Operations Control Office
Department of Water Resources

Attachment -4

cc: Mr. Craig M. Wilson, Delta Watermaster
State Water Resources Control Board
1001 I Street
Sacramento, California 95812

Carl Wilcox
California Department of Fish and Wildlife
1416 9th Street
Sacramento, California 95814

Ms. Maria Rae
Central Valley Office Supervisor
National Marine Fisheries Service
650 Capitol Mall, Suite 5-100
Sacramento, California 95814

Ms. Kim Turner
Assistant Field Supervisor
Bay-Delta Fish & Wildlife Office
U.S. Fish & Wildlife Service
650 Capitol Mall, Suite 8-300
Sacramento, California 95814

Mr. Les Grober
State Water Resources Control Board
Division of Water Rights
1001 I Street
Sacramento, California 95812
(w/encl to each)

Attachment 1

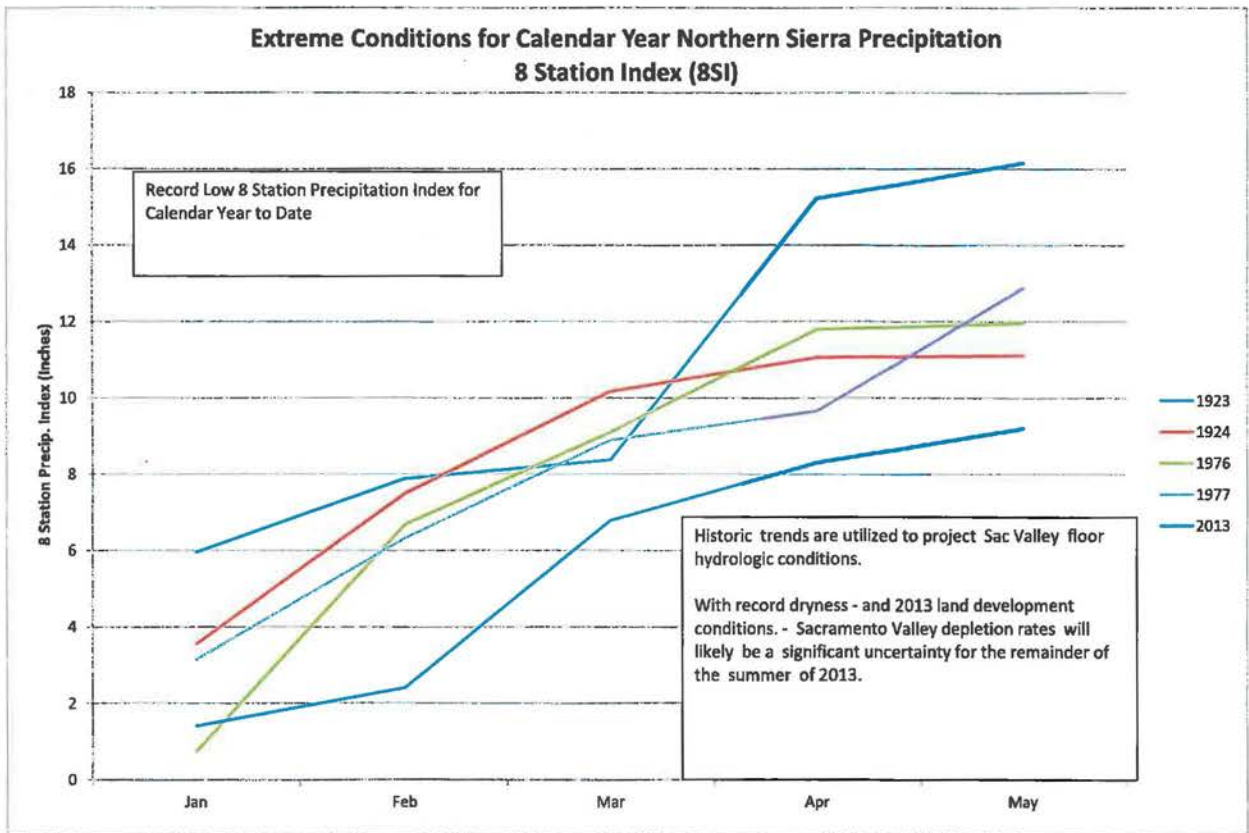

Attachment 2

Drought Severity Index by Division
Weekly Value for Period Ending MAY 18, 2013
Long Term Palmer

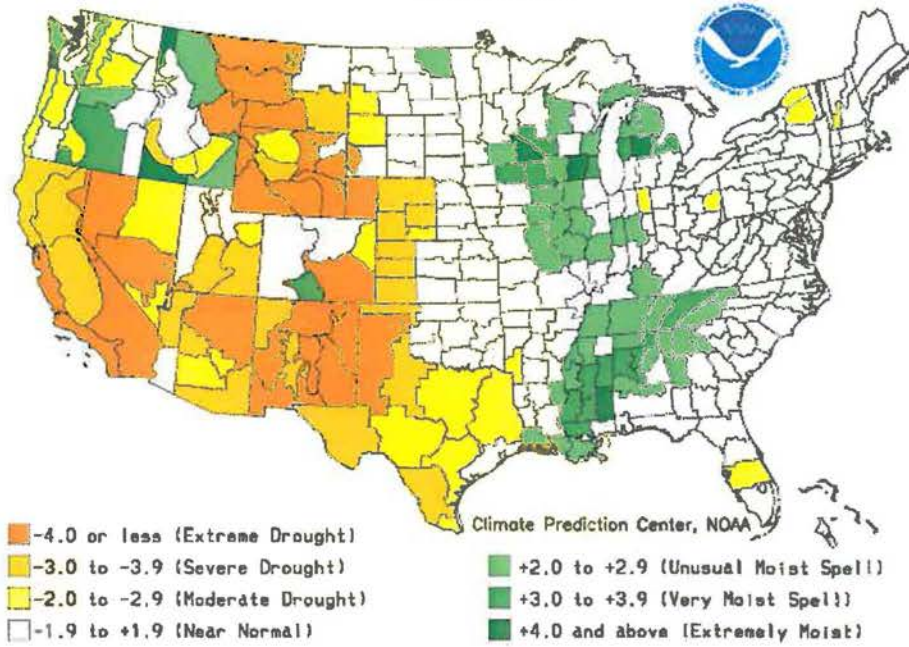

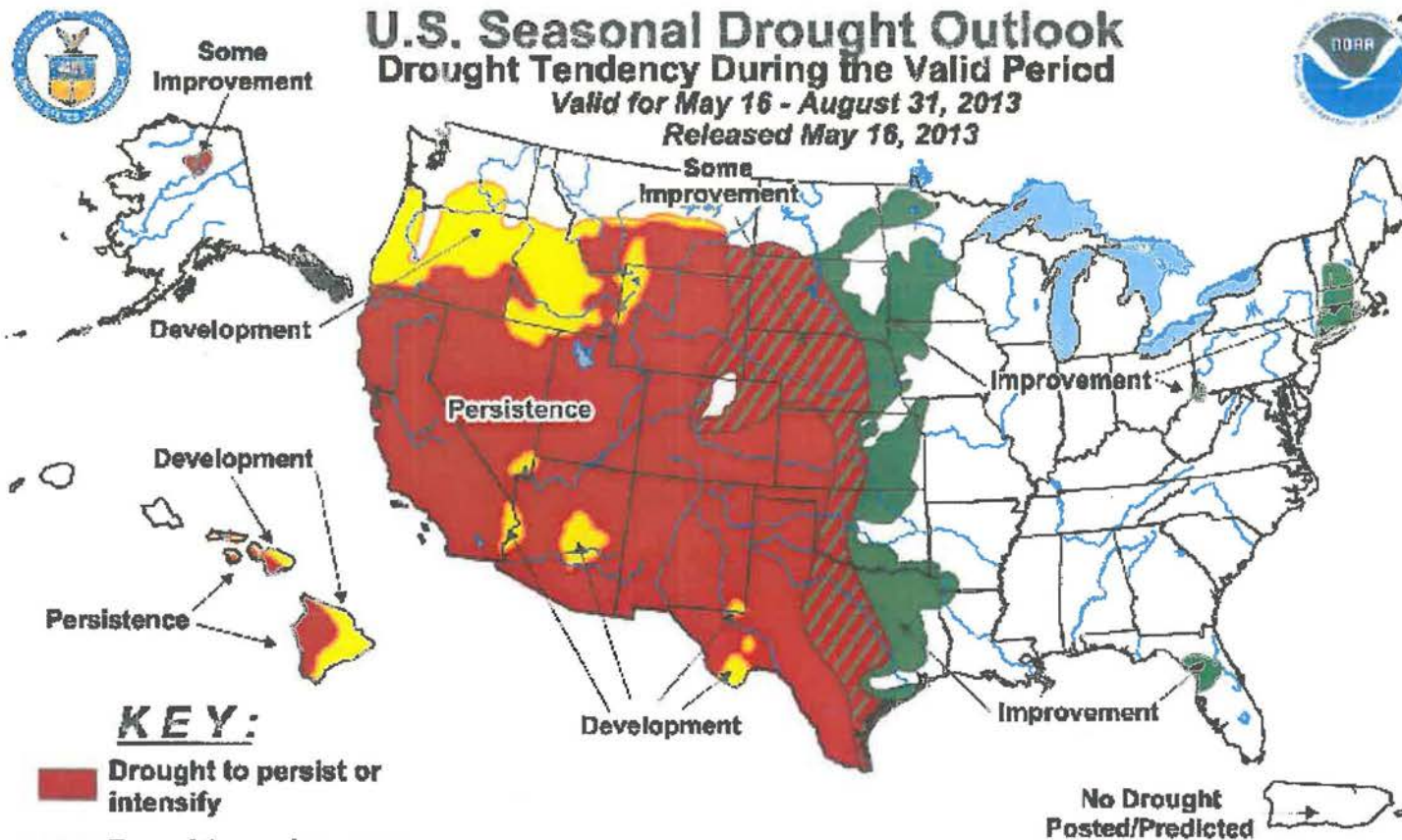

KEY:

- Drought to persist or intensify
- Drought ongoing, some improvement
- Drought likely to improve, impacts ease
- Drought development likely

Depicts large-scale trends based on subjectively derived probabilities guided by short- and long-range statistical and dynamical forecasts. Short-term events -- such as individual storms -- cannot be accurately forecast more than a few days in advance. Use caution for applications -- such as crops -- that can be affected by such events. "Ongoing" drought areas are approximated from the Drought Monitor (D1 to D4 intensity). For weekly drought updates, see the latest U.S. Drought Monitor. NOTE: the green improvement areas imply at least a 1-category improvement in the Drought Monitor intensity levels, but do not necessarily imply drought elimination.

Attachment 3

Attachment 4

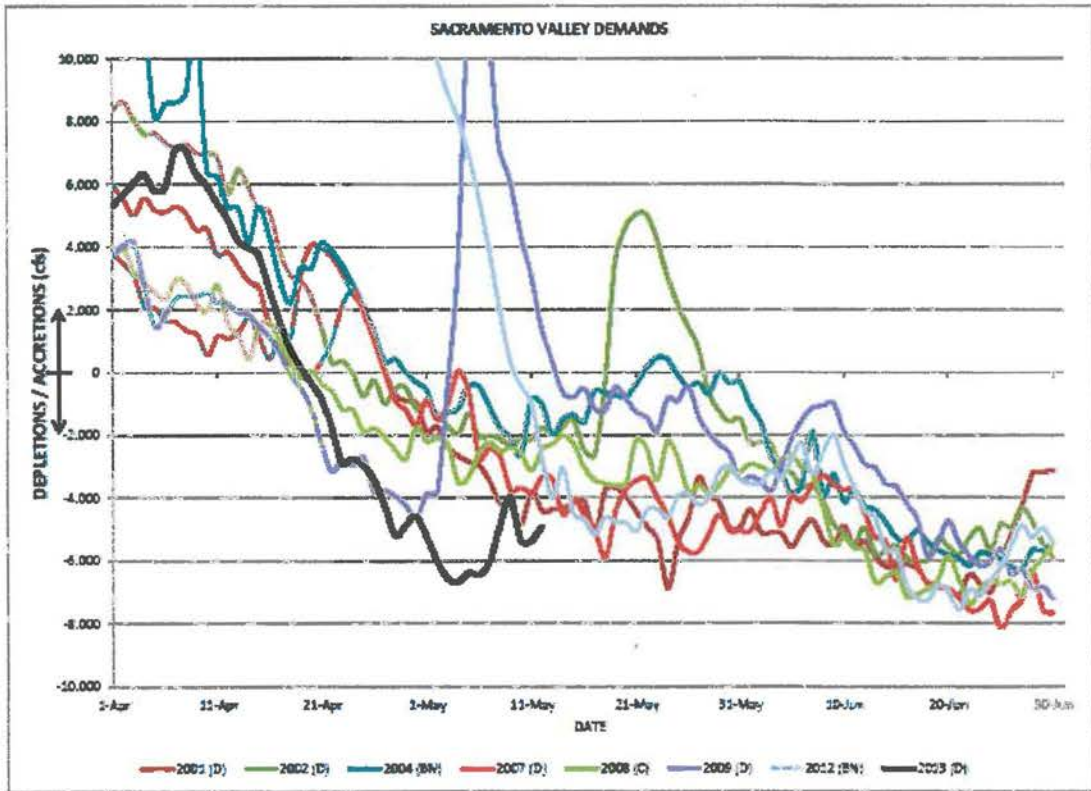

Nomellini, Grilli McDaniel PLCs

From: Wilcox, Carl@Wildlife [Carl.Wilcox@wildlife.ca.gov]
Sent: Friday, May 24, 2013 4:04 PM
To: Marcus, Felicia@Waterboards; Howard, Tom@Waterboards; Wilson, Craig@Waterboards; Grober, Les@Waterboards
Cc: Riddle, Diane@Waterboards; Leahigh, John@DWR; pfujitani@usbr.gov; Dibble, Chad@Wildlife; Maria Rea - NOAA Federal; Garwin.Yip@noaa.gov; Jennifer_norris@fws.gov; Kim_S_Turner@fws.gov
Subject: CDFW concurrence with proposed changes to Delta WQ standards requested by DWR and Reclamation

Board Chair Marcus,

This e-mail is to provide California Department of Fish & Wildlife (CDFW) support/concurrence regarding the U.S. Bureau of Reclamation's (Reclamation) and California Department of Water Resources' (DWR) proposal that the SWRCB change the Sacramento Valley Water Year Hydrologic Classification Index (40-30-30) water year type from "dry" to "critical" as it pertains to the Water Quality Objectives for Agricultural Beneficial Uses under D-1641 at the following Western Delta and Interior Delta monitoring stations:

- * Sacramento River at Emmaton, Station D-22;
- * San Joaquin River at Jersey Point, Station D-15;
- * South Fork Mokelumne River at Terminus, Station C-13; and
- * San Joaquin River at San Andreas Landing, Station C-4.

This request is to support applying the new water year classification as soon as possible, through August 15, 2013. The biggest benefit to changing the water year type for the specific water quality stations is increased storage in (or conversely, reducing the rate of drawdown of) Shasta Reservoir. This will likely benefit the life history needs of the 2013 cohorts of Chinook salmon, in addition to providing higher carryover storage (than otherwise would be realized) to begin water year 2014.

The proposal was discussed on a conference call today, Friday, May 24, among members of the SWRCB, Reclamation, DWR, U.S. Fish and Wildlife Service (USFWS), CDFW, and National Marine Fisheries Service (NMFS). In addition, the fish agencies conferred on the proposal and concur. The USFWS and NMFS will send separate e-mails expressing their support for the proposal. It is our understanding that a letter making the subject request will be forthcoming this afternoon. CDFW is providing this email concurrence to allow for a timely decision to maximize protection of Shasta storage to protect Chinook salmon. Any change in the formal submission by DWR and Reclamation to the SWRCB this afternoon from what is described above, will require re-evaluation by the CDFW before we could provide our concurrence.

Carl Wilcox
 Policy Advisor to the Director for the Delta California Department of Fish and Wildlife
 7329 Silverado Trail
 Napa, CA 94558
 Cell 707-738-4134
 Office 707-944-5584
 Carl.Wilcox@wildlife.ca.gov

Nomellini, Grilli & McDaniel PLCs

From: Maria Rea - NOAA Federal [maria.rea@noaa.gov]
Sent: Friday, May 24, 2013 4:50 PM
To: Marcus, Felicia@Waterboards; Howard, Tom@Waterboards; Wilson, Craig@Waterboards; Grober, Les@Waterboards; Riddle, Diane@Waterboards
Cc: Garwin.Yip@noaa.gov; RMILLIGAN@usbr.gov; pfujitani@usbr.gov; Leahigh, John@DWR; Dan_Castleberry@r1. Gov; Wilcox, Carl@Wildlife
Subject: NMFS support for change petition to D-1641

Dear Felicia and Tom:

This e-mail is to provide NOAA's National Marine Fisheries Service's (NMFS) support/concurrence regarding the U.S. Bureau of Reclamation's (Reclamation) and California Department of Water Resources' (DWR) proposal. As I understand it, and as discussed on a conference call this morning among members of the SWRCB, Reclamation, DWR, U.S. Fish and Wildlife Service (USFWS), California Department of Fish and Wildlife (CDFW), and NMFS, Reclamation and DWR will request that the SWRCB change the Sacramento Valley Water Year Hydrologic Classification Index (40-30-30) water year type from "dry" to "critical" as it pertains to the Water Quality Objectives for Agricultural Beneficial Uses under D-1641 at the following Western Delta and Interior Delta monitoring stations:

- Sacramento River at Emmaton, Station D-22;
- San Joaquin River at Jersey Point, Station D-15;
- South Fork Mokelumne River at Terminus, Station C-13; and
- San Joaquin River at San Andreas Landing, Station C-4.

This request is to support applying the new water year classification as soon as possible, through August 15, 2013. The biggest benefit to changing the water year type for the specific water quality stations is increased storage in (or conversely, reducing the rate of drawdown of) Shasta Reservoir. This will likely benefit the life history needs of the 2013 cohorts of Chinook salmon, in addition to providing higher carryover storage (than otherwise would be realized) to begin water year 2014. For example, Reclamation is currently releasing 13,000 cfs from Keswick Dam partly as a result of the Delta Cross Channel being open over the Memorial Day weekend and partly because of the spring tide, but largely to maintain compliance with the Emmaton water quality standard. In addition, the May forecast at the 90% exceedance hydrology indicates that the projected end of September (EOS) carryover storage at Shasta Reservoir is 1.527 million acre feet (MAF). The NMFS biological opinion on the long-term operations of the Central Valley Project and State Water Project does not have a minimum EOS carryover storage requirement in Shasta Reservoir. However, although the requirements in Action I.2.3.C pertain to the February forecast, it does acknowledge and provide for drought exception procedures if a Clear Creek Temperature Compliance Point or 1.9 MAF EOS storage is not achievable, indicating that the forecasted carryover storage of 1.527 MAF is very low.

In addition, the fish agencies conferred on the proposal as discussed this morning, and also concur. The USFWS and CDFW will send separate e-mails expressing their support for the proposal.

Please let me know if you have any questions or need more information. My cell phone number is (916) 799-2359.

- Maria

Maria Rea
Supervisor, Central Valley Office, NOAA Fisheries

Nomellini, Grilli & McDaniel PLCs

From: michael_chotkowski@fws.gov
Sent: Tuesday, May 28, 2013 2:08 PM
To: Marcus, Felicia@Waterboards; Howard, Tom@Waterboards; Wilson, Craig@Waterboards; Grober, Les@Waterboards
Cc: Riddle, Diane@Waterboards; Leahigh, John@DWR; pfujitani@usbr.gov; Dibble, Chad@Wildlife; Maria Rea - NOAA Federal; Garwin.Yip@noaa.gov; Jennifer_norris@fws.gov; Kim_S_Turner@fws.gov
Subject: FWS concurrence with proposed changes to Delta WQ standards, as requested by Reclamation and DWR

Board Chair Marcus,

This email expresses the U.S. Fish and Wildlife Service's (Service) support for the State Water Board's proposal to implement the U.S. Bureau of Reclamation (Reclamation) and California Department of Water Resources (DWR) request to change the 40-30-30 Sacramento Valley water year type from "dry" to "critical," specifically as it pertains to relaxing the D-1641 water quality objectives for agricultural beneficial uses at four stations in the western Delta:

- * Sacramento River at Emmaton, Station D-22;
- * San Joaquin River at Jersey Point, Station D-15;
- * South Fork Mokelumne River at Terminus, Station C-13; and
- * San Joaquin River at San Andreas Landing, Station C-4.

The proposed change to the water year type for the specific water quality stations would reduce drawdown of Shasta Reservoir. This will likely benefit the early life history needs of the 2013 cohorts of Chinook salmon, in addition to providing higher carryover storage (than otherwise would be realized) to begin water year 2014. In this unusual year, the biological benefits to imperiled salmon appear large enough to outweigh our concern about the potentially adverse effects of the concomitant reduction in Delta outflow during these months.

The change in EC standard at these stations would occur immediately and last through August 15, 2013. The Service supports implementation of the proposal on a one-time basis that reflects unusual winter-run Chinook concerns this year, so long as implementation does not affect management of OMR flow to protect juvenile delta smelt in accordance with the Service's 2008 OCAP Biological Opinion.

The Service will continue to work cooperatively with its Federal and State partners to ensure that the CVP and SWP operations provide adequate protection for Threatened and Endangered species while delivering water that benefits 25 million agricultural and urban water users throughout California.

Mike Chotkowski
Field Supervisor, Bay-Delta Fish and Wildlife Office
650 Capitol Mall
Sacramento, CA 95814
(916) 930-5632

Nomellini, Grilli & McDaniel PLCs

From: Howard, Tom@Waterboards [Tom.Howard@waterboards.ca.gov]
Sent: Friday, May 24, 2013 5:56 PM
To: Maria Rea - NOAA Federal; Marcus, Felicia@Waterboards; Wilson, Craig@Waterboards; Grober, Les@Waterboards; Riddle, Diane@Waterboards
Cc: Garwin.Yip@noaa.gov; RMILLIGAN@usbr.gov; pfujitani@usbr.gov; Leahigh, John@DWR; Dan_Castleberry@r1. Gov; Wilcox, Carl@Wildlife
Subject: RE: NMFS support for change petition to D-1641

In the interest of making the best use of limited water supplies, and maintaining cold water pool storage in Shasta Reservoir, I want to provide a timely initial response to emails from the National Marine Fisheries Service and the California Department of Fish and Wildlife (fish agencies). The fish agencies support a change in the Sacramento Valley Water Year Hydrologic Classification Index (40-30-30) water year type from "dry" to "critical" as it pertains to the Water Quality Objectives for Agricultural Beneficial Uses under D-1641 at the following Western Delta and Interior Delta monitoring stations:

- Sacramento River at Emmaton, Station D-22;
- San Joaquin River at Jersey Point, Station D-15;
- South Fork Mokelumne River at Terminus, Station C-13; and
- San Joaquin River at San Andreas Landing, Station C-4.

The State Water Board staff will not recommend any action if the projects operate to meet the critically dry year objectives for Western and Central Delta agricultural objectives, instead of operating to meet dry year objectives through August 15, 2013. Our intent to not take any action is conditioned on submittal of a temperature management plan pursuant to State Water Board Order 90-5 within one week of May 28, operation in accordance with the plan, and any further conditions determined by the Executive Director of the State Water Board. Furthermore, the Projects will be required to include an accounting of operations under the change in water year classification.

I will follow-up with an expanded response on Tuesday May 28 after receipt of any requests related to these Delta operations from the Department of Water resources and the United States Bureau of Reclamation.

I believe in the future that more timely exchange of information regarding operational issues will alleviate situations of this nature.

From: Maria Rea - NOAA Federal [mailto:maria.rea@noaa.gov]
Sent: Friday, May 24, 2013 4:50 PM
To: Marcus, Felicia@Waterboards; Howard, Tom@Waterboards; Wilson, Craig@Waterboards; Grober, Les@Waterboards; Riddle, Diane@Waterboards
Cc: Garwin.Yip@noaa.gov; RMILLIGAN@usbr.gov; pfujitani@usbr.gov; Leahigh, John@DWR; Dan_Castleberry@r1. Gov; Wilcox, Carl@Wildlife
Subject: NMFS support for change petition to D-1641

Dear Felicia and Tom:

This e-mail is to provide NOAA's National Marine Fisheries Service's (NMFS) support/concurrence regarding the U.S. Bureau of Reclamation's (Reclamation) and California Department of Water Resources' (DWR) proposal. As I understand it, and as discussed on a conference call this morning among members of the SWRCB, Reclamation, DWR, U.S. Fish and Wildlife Service (USFWS), California Department of Fish and Wildlife (CDFW), and NMFS, Reclamation and DWR will request that the SWRCB change the Sacramento Valley Water Year Hydrologic Classification Index (40-30-30)

water year type from “dry” to “critical” as it pertains to the Water Quality Objectives for Agricultural Beneficial Uses under D-1641 at the following Western Delta and Interior Delta monitoring stations:

- Sacramento River at Emmaton, Station D-22;
- San Joaquin River at Jersey Point, Station D-15;
- South Fork Mokelumne River at Terminus, Station C-13; and
- San Joaquin River at San Andreas Landing, Station C-4.

This request is to support applying the new water year classification as soon as possible, through August 15, 2013. The biggest benefit to changing the water year type for the specific water quality stations is increased storage in (or conversely, reducing the rate of drawdown of) Shasta Reservoir. This will likely benefit the life history needs of the 2013 cohorts of Chinook salmon, in addition to providing higher carryover storage (than otherwise would be realized) to begin water year 2014. For example, Reclamation is currently releasing 13,000 cfs from Keswick Dam partly as a result of the Delta Cross Channel being open over the Memorial Day weekend and partly because of the spring tide, but largely to maintain compliance with the Emmaton water quality standard. In addition, the May forecast at the 90% exceedance hydrology indicates that the projected end of September (EOS) carryover storage at Shasta Reservoir is 1.527 million acre feet (MAF). The NMFS biological opinion on the long-term operations of the Central Valley Project and State Water Project does not have a minimum EOS carryover storage requirement in Shasta Reservoir. However, although the requirements in Action I.2.3.C pertain to the February forecast, it does acknowledge and provide for drought exception procedures if a Clear Creek Temperature Compliance Point or 1.9 MAF EOS storage is not achievable, indicating that the forecasted carryover storage of 1.527 MAF is very low.

In addition, the fish agencies conferred on the proposal as discussed this morning, and also concur. The USFWS and CDFW will send separate e-mails expressing their support for the proposal.

Please let me know if you have any questions or need more information. My cell phone number is (916) 799-2359.

- Maria

Maria Rea
Supervisor, Central Valley Office, NOAA Fisheries

Nomellini, Grilli_McDaniel PLCs

From: Grober, Les@Waterboards [Les.Grober@waterboards.ca.gov]
Sent: Thursday, May 30, 2013 10:16 AM
To: Terry, Melinda @northdw.com; ngmplcs@pacbell.net
Subject: FW: May 29 2013 Letter to USBR and DWR on Actions to Conserve Cold Water Pool

Attachments: signed response letter 5-29-13.pdf; Milligan,R. -2013-05_SWRCB Water Right Decision 1641 Water Year Classification.pdf



signed



Milligan,R.

signed response letter 5-29-13.pdf; Milligan,R. -2013-05_SWRCB W

Here is the follow-up letter.

From: Saechao, Dramey@Waterboards
Sent: Wednesday, May 29, 2013 5:12 PM
To: Roose, David@DWR; RMILLIGAN@usbr.gov
Cc: Howard, Tom@Waterboards; maria.rea@noaa.gov; Wilcox, Carl@Wildlife;
Kim_S_Turner@fws.gov; Foresman.Erin@epamail.epa.gov; Terry, Melinda @northdw.com;
ngmplcs@pacbell.net; pfujitani@usbr.gov; Leahigh, John@DWR
Subject: May 29 2013 Letter to USBR and DWR on Actions to Conserve Cold Water Pool

Please see the attached May 29, 2013 letter from Craig Wilson, the Delta Watermaster, to the U.S. Bureau of Reclamation and California Department of Water Resources regarding actions to conserve cold water pool in Shasta Reservoir for fishery resources. The letter from the Bureau and Department is also attached.

Questions regarding this matter should be directed to Craig Wilson at cwilson@waterboards.ca.gov<mailto:cwilson@waterboards.ca.gov> or 916-445-5962.



EDMUND G. BROWN JR.
GOVERNOR



MATTHEW RODRIGUEZ
SECRETARY FOR
ENVIRONMENTAL PROTECTION

State Water Resources Control Board

Ronald Milligan, Operations Manager
Central Valley Operations Office
U.S. Bureau of Reclamation
3310 El Camino Avenue, Suite 300
Sacramento, CA 95821

David H. Roose, Chief
SWP Operations Control Office
California Department of Water Resources
Division of Operations and Maintenance
3310 El Camino Avenue, Suite 300
Sacramento, CA 95821

Dear Messrs. Milligan and Rosse:

ACTIONS TO CONSERVE COLD WATER POOL IN SHASTA RESERVOIR FOR FISHERY RESOURCES

This letter responds to your May 24, 2013 letter to Thomas Howard, Executive Director for the State Water Resources Control Board (State Water Board) regarding unprecedented dry conditions in the Sacramento Valley and needed actions to protect cold water pool (CWP) resources for fisheries purposes. In your letter you request that the State Water Board acknowledge that the water year classification for the Sacramento Valley contained in State Water Board Decision 1641 (D-1641, Figure 1, page 188) does not accurately reflect the unprecedented dry conditions that have occurred since January of this year, which are characteristic of a critically dry year determination. Specifically, you propose that the Bureau and Department comply with critically dry water year requirements for certain Delta water quality objectives instead of dry year requirements in order to conserve CWP resources in Shasta Reservoir needed to protect Chinook salmon this season.

Background

The State Water Board was first contacted regarding this matter on May 17, 2013, by Maria Rea, Supervisor of the Central Valley Office of the National Marine Fisheries Service (NOAA Fisheries). Ms. Rea emailed Mr. Howard expressing concerns that planned Shasta Reservoir releases to meet Delta water quality objectives required by D-1641 would impact winter-run Chinook salmon by depleting already low Shasta Reservoir CWP resources. Ms. Rea requested that the agencies meet as soon as possible to discuss this matter.

In the midst of these discussions, on May 20, 2013, Governor Edmund G. Brown Jr. issued an Executive Order (B-21-13) outlining California's exceptionally dry water year conditions and ordering that the Department and the State Water Board expedite the review of water transfers to address the dry conditions and water delivery limitations. As outlined in Executive Order B-21-13:

- much of California experienced record dry conditions in January through March 2013, registering historic lows on the Northern Sierra and the San Joaquin precipitation indices; and

FELICIA MARCUS, CHAIR | THOMAS HOWARD, EXECUTIVE DIRECTOR

1001 I Street, Sacramento, CA 95814 | Mailing Address: P.O. Box 100, Sacramento, Ca 95812-0100 | www.waterboards.ca.gov

Mr. Ronald Milligan
Mr. David H. Roose

- 2 -

- record dry and warm conditions resulted in a snowpack substantially below average, with estimated May water content in the statewide snowpack being only 17 percent of average and with the spring snowmelt season now being well underway.

On May 22, 2013, State Water Board staff met with staff from the Bureau and Department to discuss possible Shasta Reservoir CWP actions. On May 24, 2013, State Water Board staff again met with staff from the Department and Bureau as well as staff from NOAA Fisheries, the U.S. Fish and Wildlife Service (USFWS), and the California Department of Fish and Wildlife (CDFW) (collectively fisheries agencies) to discuss Shasta Reservoir CWP actions. The fisheries agencies agreed on the need to take actions to conserve CWP resources in Shasta Reservoir and concurred with a proposal that the Department and Bureau operate to meet critically dry year requirements for the Western and Interior Delta water quality objectives for the protection of agriculture included in Table 2 of D-1641 (page 182), which include the following stations:

- Sacramento River at Emmaton, Station D-22;
- San Joaquin River at Jersey Point, Station D-15;
- South Fork Mokelumne River at Terminus, Station C-13; and
- San Joaquin River at San Andreas Landing, Station C-4.

The fisheries agencies requested additional time and discussion to consider any further actions related to Delta outflow or other requirements due to potential fisheries related impacts. On May 24, 2013, Carl Wilcox of the CDFW and Maria Rea of NOAA Fisheries sent emails to State Water Board staff in support of the proposal that the Bureau and Department operate to meet critically dry year conditions for the above mentioned Western and Interior Delta compliance stations through August 15, 2013 (attached). On May 28, 2013, Michael Chotkowski with the USFWS also submitted an email of support for the changes mentioned above (attached).

Prior to receipt of your letter on May 24, 2013, Mr. Howard sent an initial response regarding this matter indicating that, in the interest of making the best use of limited water supplies and maintaining cold water pool storage in Shasta Reservoir, the State Water Board staff will not recommend taking any action if the projects operate to meet the critically dry year objectives for the Western and Interior Delta agricultural objectives, instead of operating to meet dry year objectives through August 15, 2013. Mr. Howard indicated that the intent to not take any action was conditioned on submittal of a temperature management plan pursuant to State Water Board Order 90-5 within one week of May 28, 2013, and operation in accordance with the plan, and any further conditions determined by the Executive Director of the State Water Board. Mr. Howard also indicated that the Bureau and Department will be required to include a water accounting under the change in operations. Mr. Howard indicated that we would follow up after receipt of a specific request from the Bureau and Department.

Proposal

In your letter you propose to meet critically dry year requirements pursuant to D-1641 for the Sacramento Valley, including requirements included in Table 3 for the protection of fish and wildlife, in order to conserve CWP resources. In your letter, you state that, although the January through April period during 2013 was the driest on record, the November and December

Mr. Ronald Milligan
Mr. David H. Roose

- 3 -

precipitation was sufficient to result in a Sacramento Valley classification of "dry" for water year 2013. Your letter further states that nearly 80 percent of this water year's precipitation occurred in October, November and December 2012, and an abnormally large portion of this fell as rain rather than snow as a result of warmer than normal conditions for that time of year. This combined with critically dry conditions in the months since the first of the year has resulted in minimal snow pack in the Sierra Nevada in the critical spring months. As of May 1, 2013, the Northern Sierra snowpack was only about 48 percent of the historical April 1 value and about 17 percent of normal. Further, you point out that unusually high stream depletions in the Sacramento Valley have also contributed to reduced storage levels.

Your letter explains that meeting dry year objectives could jeopardize the Bureau and Department's ability to meet objectives designed to protect fisheries later in the year. In particular, the Bureau has expressed concern that it may not be able meet the temperature requirement necessary to protect salmon present in the Sacramento River during the summer and fall if the CWP in Shasta Reservoir continues to be depleted. You state that operating to meet critically dry water year requirements for the Western and Interior Delta from May through August 15 of this year could result in a gain of approximately 115 thousand acre-feet (TAF) of water in upstream reservoirs at the end of September. You indicate that including the Delta outflow requirement (included in Table 3 of D-1641) for the same period would increase the gain in reservoir carryover storage to approximately 185 TAF. You further indicate that compliance with critically dry conditions will result in water quality conditions in the North Delta that are consistent with the current hydrology.

Response to Proposal

Article X, section 2 of the California Constitution sets forth a directive to maximize the reasonable and beneficial use of the State's waters. As such, this constitutional mandate provides an important consideration where statutory water rights provisions vest discretion in the State Water Board. We have reviewed the unique factors of your request and the recommendations of the fisheries agencies. As the person delegated by the State Water Board to act on water right permit terms that apply to conditions in the Delta, I will not object or take any action if the Bureau and Department operate to meet critically dry year objectives for Western and Interior Delta agricultural beneficial uses included in Table 2 of D-1641 instead of operating to meet dry year objectives through August 15, 2013. This conclusion is conditioned as specified in the above mentioned email from the State Water Board's Executive Director Thomas Howard. Specifically, the Bureau and Department shall submit a temperature management plan pursuant to State Water Board Order 90-5 by **June 4, 2013**, and shall operate in accordance with the approved plan to maximize temperature benefits to fisheries resources. The Bureau and Department shall consult with the fisheries agencies concerning temperature management decisions and shall immediately inform the State Water Board regarding any fisheries agencies concerns and proposed resolution of those concerns. The Bureau and Department shall implement additional actions as determined by me or the Executive Director of the State Water Board. The Bureau and Department shall also submit a water accounting to the State Water Board under the change in operations by **August 22, 2013**.

I understand that Delta outflow requirements are not currently controlling operational decisions related to releases from Shasta Reservoir, but likely will be in the next several weeks. In order to determine whether any additional changes to operations to meet Delta outflow or other objectives required by D-1641 should be made to protect CWP resources, the Bureau and Department should immediately consult with the fisheries agencies and State Water Board staff.

Mr. Ronald Milligan
Mr. David H. Roose

- 4 -

I will consider additional actions to conserve CWP resources upon receipt of input from the fisheries agencies on those matters.

In the future, the State Water Board staff and I expect discussions regarding compliance matters to begin as soon as potential issues are identified in order to allow the greatest flexibility to address these issues. The State Water Board will consider whether appropriate coordination took place in a timely manner when considering future enforcement action.

If you have any questions, please contact me at cwilson@waterboards.ca.gov or 916-445-5962. Written correspondence should be addressed as follows:

State Water Resources Control Board
Office of Delta Watermaster
Attn: Craig Wilson
P.O. Box 100
Sacramento, CA 95812

Sincerely,

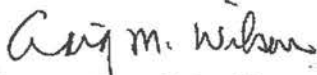

Craig Wilson, Delta Watermaster
State Water Resources Control Board

Enclosures

cc: Thomas Howard, Executive Director
State Water Resources Control Board
1001 I Street
Sacramento, CA 95812

Maria Rea, Central Valley Office Supervisor
National Marine Fisheries Service
650 Capitol Mall, Suite 5-100
Sacramento, CA 95814

Carl Wilcox
California Department of Fish and Wildlife
1416 9th Street
Sacramento, CA 95814

Kim Turner, Assistant Field Supervisor
U.S. Fish & Wildlife Service
650 Capitol Mall, Suite 8-300
Sacramento, CA 95814

cc: Continues on next page.

Mr. Ronald Milligan
Mr. David H. Roose

- 5 -

cc: Erin Foresman
USEPA Region 9
C/O NMFS 650 Capitol Mall
Sacramento, CA 95814

Melinda Terry, Manager
North Delta Water Agency
910 K Street, Suite 310
Sacramento, CA 95814

Dante Nomellini Jr.
Central Delta Water Agency
P.O. Box 1461
Stockton, CA 95201

Paul Fujitani
U.S. Bureau of Reclamation
3310 El Camino Avenue, Suite 300
Sacramento, California 95821

John Leahigh
California Department of Water Resources
3310 El Camino Avenue, Suite 300
Sacramento, California 95821

From: Wilcox, Carl@Wildlife [<mailto:Carl.Wilcox@wildlife.ca.gov>]
Sent: Friday, May 24, 2013 4:04 PM
To: Marcus, Felicia@Waterboards; Howard, Tom@Waterboards; Wilson, Craig@Waterboards; Grober, Les@Waterboards
Cc: Riddle, Diane@Waterboards; Leahigh, John@DWR; pfujitani@usbr.gov; Dibble, Chad@Wildlife; Maria Rea - NOAA Federal; Garwin.Yip@noaa.gov; Jennifer_norris@fws.gov; Kim_S_Turner@fws.gov
Subject: CDFW concurrence with proposed changes to Delta WQ standards requested by DWR and Reclamation

Board Chair Marcus,

This e-mail is to provide California Department of Fish & Wildlife (CDFW) support/concurrence regarding the U.S. Bureau of Reclamation's (Reclamation) and California Department of Water Resources' (DWR) proposal that the SWRCB change the Sacramento Valley Water Year Hydrologic Classification Index (40-30-30) water year type from "dry" to "critical" as it pertains to the Water Quality Objectives for Agricultural Beneficial Uses under D-1641 at the following Western Delta and Interior Delta monitoring stations:

- * Sacramento River at Emmaton, Station D-22;
- * San Joaquin River at Jersey Point, Station D-15;
- * South Fork Mokelumne River at Terminus, Station C-13; and
- * San Joaquin River at San Andreas Landing, Station C-4.

This request is to support applying the new water year classification as soon as possible, through August 15, 2013. The biggest benefit to changing the water year type for the specific water quality stations is increased storage in (or conversely, reducing the rate of drawdown of) Shasta Reservoir. This will likely benefit the life history needs of the 2013 cohorts of Chinook salmon, in addition to providing higher carryover storage (than otherwise would be realized) to begin water year 2014.

The proposal was discussed on a conference call today, Friday, May 24, among members of the SWRCB, Reclamation, DWR, U.S. Fish and Wildlife Service (USFWS), CDFW, and National Marine Fisheries Service (NMFS). In addition, the fish agencies conferred on the proposal and concur. The USFWS and NMFS will send separate e-mails expressing their support for the proposal. It is our understanding that a letter making the subject request will be forthcoming this afternoon. CDFW is providing this email concurrence to allow for a timely decision to maximize protection of Shasta storage to protect Chinook salmon. Any change in the formal submission by DWR and Reclamation to the SWRCB this afternoon from what is described above, will require re-evaluation by the CDFW before we could provide our concurrence.

Carl Wilcox
Policy Advisor to the Director for the Delta California Department of Fish and Wildlife
7329 Silverado Trail
Napa, CA 94558
Cell 707-738-4134
Office 707-944-5584
Carl.Wilcox@wildlife.ca.gov

From: Maria Rea - NOAA Federal [mailto:maria.rea@noaa.gov]

Sent: Friday, May 24, 2013 4:50 PM

To: Marcus, Felicia@Waterboards; Howard, Tom@Waterboards; Wilson, Craig@Waterboards; Grober, Les@Waterboards; Riddle, Diane@Waterboards

Cc: Garwin.Yip@noaa.gov; RMILLIGAN@usbr.gov; pfujitani@usbr.gov; Leahigh, John@DWR; Dan_Castleberry@r1.Gov; Wilcox, Carl@Wildlife

Subject: NMFS support for change petition to D-1641

Dear Felicia and Tom:

This e-mail is to provide NOAA's National Marine Fisheries Service's (NMFS) support/concurrence regarding the U.S. Bureau of Reclamation's (Reclamation) and California Department of Water Resources' (DWR) proposal. As I understand it, and as discussed on a conference call this morning among members of the SWRCB, Reclamation, DWR, U.S. Fish and Wildlife Service (USFWS), California Department of Fish and Wildlife (CDFW), and NMFS, Reclamation and DWR will request that the SWRCB change the Sacramento Valley Water Year Hydrologic Classification Index (40-30-30) water year type from "dry" to "critical" as it pertains to the Water Quality Objectives for Agricultural Beneficial Uses under D-1641 at the following Western Delta and Interior Delta monitoring stations:

- Sacramento River at Emmaton, Station D-22;
- San Joaquin River at Jersey Point, Station D-15;
- South Fork Mokelumne River at Terminus, Station C-13; and
- San Joaquin River at San Andreas Landing, Station C-4.

This request is to support applying the new water year classification as soon as possible, through August 15, 2013. The biggest benefit to changing the water year type for the specific water quality stations is increased storage in (or conversely, reducing the rate of drawdown of) Shasta Reservoir. This will likely benefit the life history needs of the 2013 cohorts of Chinook salmon, in addition to providing higher carryover storage (than otherwise would be realized) to begin water year 2014. For example, Reclamation is currently releasing 13,000 cfs from Keswick Dam partly as a result of the Delta Cross Channel being open over the Memorial Day weekend and partly because of the spring tide, but largely to maintain compliance with the Emmaton water quality standard. In addition, the May forecast at the 90% exceedance hydrology indicates that the projected end of September (EOS) carryover storage at Shasta Reservoir is 1.527 million acre feet (MAF). The NMFS biological opinion on the long-term operations of the Central Valley Project and State Water Project does not have a minimum EOS carryover storage requirement in Shasta Reservoir. However, although the requirements in Action 1.2.3.C pertain to the February forecast, it does acknowledge and provide for drought exception procedures if a Clear Creek Temperature Compliance Point or 1.9 MAF EOS storage is not achievable, indicating that the forecasted carryover storage of 1.527 MAF is very low.

In addition, the fish agencies conferred on the proposal as discussed this morning, and also concur. The USFWS and CDFW will send separate e-mails expressing their support for the proposal.

Please let me know if you have any questions or need more information. My cell phone number is (916) 799-2359.

- Maria

Maria Rea

Supervisor, Central Valley Office, NOAA Fisheries

From: "Chotkowski, Michael" <michael_chotkowski@fws.gov>
Date: May 28, 2013 6:21:50 PM PDT
To: <Felicia.Marcus@waterboards.ca.gov>, <Tom.Howard@waterboards.ca.gov>, <Craig.Wilson@waterboards.ca.gov>, <Les.Grober@waterboards.ca.gov>
Cc: <Diane.Riddle@waterboards.ca.gov>, "Leahigh, John@DWR" <John.Leahigh@water.ca.gov>, PAUL FUJITANI <PFujitani@usbr.gov>, "Dibble, Chad@Wildlife" <Chad.Dibble@wildlife.ca.gov>, Maria Rea - NOAA Federal <maria.rea@noaa.gov>, Garwin Yip - NOAA Federal <garwin.yip@noaa.gov>, "Jen Norris" <jennifer_norris@fws.gov>, Kim <kim_s_turner@fws.gov>, Roger Guinee <roger_guinee@fws.gov>
Subject: Update to: FWS concurrence with proposed changes to Delta WQ standards, as requested by Reclamation and DWR

Board Chair Marcus,

Note: This email supersedes one I sent earlier today, which reflected a misunderstanding on my part. Apologies. Please discard the earlier email and substitute this one.

This email expresses the U.S. Fish and Wildlife Service's (Service) support for the State Water Board's proposal to implement the U.S. Bureau of Reclamation (Reclamation) and California Department of Water Resources (DWR) request to change the 40-30-30 Sacramento Valley water year type from "dry" to "critical," specifically as it pertains to relaxing the D-1641 water quality objectives for agricultural beneficial uses at four stations in the western Delta:

- * Sacramento River at Emmaton, Station D-22;
- * San Joaquin River at Jersey Point, Station D-15;
- * South Fork Mokelumne River at Terminus, Station C-13; and
- * San Joaquin River at San Andreas Landing, Station C-4.

The proposed change to the water year type for the specific water quality stations would reduce drawdown of Shasta Reservoir. This will likely benefit the early life history needs of the 2013 cohorts of Chinook salmon, in addition to providing higher carryover storage (than otherwise would be realized) to begin water year 2014.

The change in EC standard at these stations would occur immediately and last through August 15, 2013. The Service supports implementation of the proposal on a one-time basis, so long as implementation does not affect management of OMR flow to protect juvenile delta smelt in accordance with the Service's 2008 OCAP Biological Opinion.

It is our understanding that some discussions related to possible changes in Delta outflow have yet to occur. We will evaluate proposals related to deviations from the D-1641 Delta outflow standards when/if they are proposed.

The Service will continue to work cooperatively with its Federal and State partners to ensure that the CVP and SWP operations provide adequate protection for Threatened and Endangered species while delivering water that benefits 25 million agricultural and urban water users throughout California.

--
Mike Chotkowski
Field Supervisor, Bay-Delta Fish and Wildlife Office
650 Capitol Mall, Suite 8-300
Sacramento CA 95814
(916) 930-5632 Office
(916) 812-0155 Cell



BUREAU OF RECLAMATION
 Central Valley Operation Office
 3310 El Camino Avenue, Suite 300
 Sacramento, California 95821



DEPARTMENT OF WATER RESOURCES
 Division of Operations and Maintenance
 3310 El Camino Avenue, Suite 300
 Sacramento, California 95821

MAY 24 2013

IN REPLY REFER TO:

CVO-100
 WTR-4.10

Thomas Howard
 Executive Director
 State Water Resources Control Board
 1001 I Street
 Sacramento, California 95814

Subject: State Water Resources Control Board Water Right Decision 1641 Water Year
 Classification

Dear Mr. Howard:

The Department of Water Resources (DWR) and the United States Bureau of Reclamation (Reclamation) request that the State Water Resources Control Board (SWRCB) acknowledge that the water year classification for the Sacramento Valley based on the equation provided in Attachment 1, page 188 of Revised Water Rights Decision 1641 (D-1641) does not accurately reflect the unprecedented dry conditions experienced in 2013. Instead, the hydrologic conditions experienced between January and the present are characteristic of a "Critical" water year type. The current miscategorization in water year classification is projected to affect the storage of cold water pool for fisheries purposes due to controlling D-1641 Delta objectives in the May through August period. These objectives are:

- 1) EC parameters for Sacramento River at Emmaton (Interagency Station Number D-22), San Joaquin River at Jersey Point (Interagency Station Number D-15), South Fork Mokelumne River at Terminous (Interagency Station Number C-13), and San Joaquin River at San Andreas (interagency Station Number C-4) as defined in Table 2 on page 182
- 2) Delta Outflow, as defined on Table 3 on Page 184.

Subject: SWRCB Water Right Decision 1641 Water Year Classification

2

Water year classification also affects other objectives listed in D-1641 to a lesser degree, but it is not anticipated that those objectives will significantly control Delta operations in 2013.

Summary of Relevant Facts:

D-1641 imposes water quality objectives on the Central Valley Project (CVP) and State Water Project (SWP). Several of the objectives are dependent on the water year type as determined by the May 1, Sacramento Valley Index and the San Joaquin Valley Index. Although the January through April period during 2013 was the driest on record, the November and December precipitation was sufficient to result in a Sacramento Valley classification of "Dry" for water year 2013. The "Dry" water year classification is not representative of the extreme hydrological conditions in Northern California this calendar year and the water quality objectives based on this water year type could result in significant adverse impacts to the cold water pool operations at Shasta Reservoir. In fact, Governor Brown's recent executive order B-21-13 recognizes that, "much of California experienced record dry conditions in January through March 2013, registering historic lows on the Northern Sierra" and "record dry and warm conditions resulted in a snowpack substantially below average, with estimated May water content in the statewide snowpack being only 17 percent of average."

The 2013 water year has been particularly challenging with double the normal precipitation in November and December and historically low values from January into May. The current Northern Sierra 8 Station Precipitation Index from January 1, 2013 through May 15 is about 8.8 inches. Without additional measurable precipitation in May, this figure will represent the driest Northern Sierra 8-Station Precipitation Index for the January through May period on record. Attachment 1 shows the accumulated 8-station precipitation values from January through May for some of the extremely dry years including 1924, 1976, and 1977. The nearly 80 percent of this year's precipitation occurred in the first three months of the water year, and an abnormally large portion of this fell as rain rather than snow as a result of warmer than normal conditions for that time of year. This combined with critically dry conditions in the months since the first of the year has resulted in minimal snow pack in the Sierra Nevada in the critical spring months. The Northern Sierra snowpack was only about 48% of the historical April 1 value and about 17% of normal as of May 1, 2013. Creek and small stream flows that enter the Sacramento River system below major reservoirs are running at historically low levels in response to the extended dry period. DWR's May 1, 2013 Bulletin 120 forecasts an April to July runoff 48% of normal for the Sacramento Valley. Hydrological conditions are not likely to improve and the National Oceanic and Atmospheric Administration has indicated that California is in severe to extreme drought that is likely to persist or intensify into the summer (Attachment 2).

Additionally, unusually high depletions in the Sacramento Valley are adding to the operational challenges the CVP and SWP (collectively, Projects) are facing in meeting the 2013 water year type requirements. Typically, extremely dry years with low Northern Sierra 8-Station Precipitation Index values trigger the Shasta inflow shortage criteria included in water rights settlement contracts that would reduce water supplies for the senior water rights diverters in the Sacramento Valley. Yet, this year the wetter conditions in the fall months were sufficient to require full allocations to the Sacramento Valley and Feather River settlement contractors,

Subject: SWRCB Water Right Decision 1641 Water Year Classification

3

increasing demands on Shasta and Oroville storage. Therefore, it is expected that depletions will continue to run at a high rate into the summer. DWR and Reclamation are required to make releases in order to satisfy the senior water rights of the Sacramento River and Feather River settlement contractors, and the Exchange Contractors. These contracts specify the amount of water the Projects must deliver – for the Sacramento River and Exchange Contractors, Reclamation is required to deliver 100% of the contract total in any year where the forecasted inflow to Shasta Reservoir exceeds 3.2 million acre feet (af). This target was met in 2013 – thus Reclamation is mandated to deliver 100% of the contract total, and has no discretion under the contract to reduce these deliveries.

The unusually high stream depletions (Attachment 3) were a major cause of the exceedence of the Emmaton objective that occurred in April and May. This is described in further detail in DWR and Reclamation's letter to SWRCB dated May 24, 2013. The CVP and SWP reservoir systems were in a near normal condition in January, but Reclamation and DWR have drawn heavily on the storage since then due to the extended dry period, low unregulated flow entering the system, and high depletions in the Central Valley. Reservoir releases are currently well above average for this date.

In order to meet the Dry year water quality objectives rather than the Critical objectives, DWR and Reclamation have released significant volumes of water from Oroville, Shasta, and Folsom Reservoirs. The low reservoir inflow and increased storage withdrawal is depleting the cold water pool in the reservoirs that is important to provide adequate instream fishery habitat for anadromous fish in the rivers through the summer and fall.

SWRCB Water Rights Order 90-05 requires that Reclamation operate Shasta Reservoir to meet a daily average temperature of 56 degrees Fahrenheit in the Sacramento River at a location and through periods when higher temperatures will be detrimental to the fishery. Typically, through coordination with the Sacramento River Temperature Task Group (SRTTG), the location selected is between Balls Ferry and Bend Bridge on the Sacramento River. Without recognition of the Sacramento Valley water year type actually experienced in 2013, the projected low reservoir storage and limited cold water pool this year may result in the objective occurring well upstream of Balls Ferry and Reclamation is concerned whether the 56 degree objective can be maintained at any location in the Sacramento River through the fall. The cold water pool is vital to providing adequate habitat to salmon present in the Sacramento River through the summer and into the fall for both the winter-run Chinook salmon and fall-run Chinook salmon. The SRTTG has recommended an initial temperature compliance point of Airport Road located upstream of Balls Ferry due to the limited cold water resources this year.

Due to the unprecedented hydrologic conditions discussed above including the record dry January through May period, extremely low snowpack, and unusually high Sacramento valley depletions, conditions continue to deteriorate and it is clear that meeting the dry year objectives could jeopardize the ability to meet other fisheries objectives later in the year. The reservoir storage that accumulated in the wet fall, which was originally projected to be sufficient to meet the dry year objectives, is falling rapidly due to the abnormally large valley demands and

Subject: SWRCB Water Right Decision 1641 Water Year Classification

4

Reclamation is projecting CVP September carryover storages only about 63% of average.

There is a significant difference between the volume of Delta inflow needed to achieve the Dry and Critical water quality objectives for Jersey Point and Emmaton through June 15. If Reclamation and DWR are able to begin operating to the Critical year water quality objectives in May it may be possible to achieve 100,000 to 200,000 af, of cold water benefits in the upstream reservoirs. This savings in cold water storage would improve the chances of meeting the temperature objective at Airport Road. This cold water benefit will help avoid temperature related fish losses in the Sacramento River.

The greatest benefits to the Project's reservoir storage would occur in the May to August 15 period. The compliance locations in the Western Delta and Interior Delta shown in Table 3 on Page 182 (Sacramento River at Emmaton (Interagency Station Number D-22), San Joaquin River at Jersey Point (Interagency Station Number D-15), South Fork Mokelumne River at Terminous (Interagency Station Number C-13), and San Joaquin River at San Andreas Landing (Interagency Station Number C-4) would most likely be the objectives controlling the Project operations during the May to June 15 period and changes at these locations would have the greatest impact on improving upstream storage in the immediate future. The objectives of the Delta outflow compliance location in Table 3 on page 184 often can control Project operations through the summer and operating to a critical year with respect to Delta outflow will also assist in preserving cold water pool.

Currently, DWR and Reclamation are maintaining a Net Delta Outflow well over 9,000 cubic feet per second (cfs) in order to achieve the Dry year objectives for Jersey Point and Emmaton. If the Dry classification is changed to Critical, the controlling D-1641 objective through June would be the Net Delta Outflow Index of at least 7,100 cfs in Table 3, or the export to inflow ratio of 35% in Table 3. From July through August 15, the controlling criteria for either water year classification would most likely shift among the minimum Net Delta Outflow objectives in Table 3, the salinity objectives for Jersey Point and Emmaton in Table 2, the Export to Inflow ratio of 65% in Table 3, or the Contra Costa 250 chloride objective in Table 1.

Table 2 of D-1641 requires an electrical conductivity (EC) no greater than 0.45 mmhos/cm for both Emmaton and Jersey point locations from April 1 to June 15, and 1.67 mmhos/cm for Emmaton and 1.35 mmhos/cm for Jersey Point from June 15 to August 15 under a Dry Year classification. For a Critical year these objectives are 2.78 mmhos/cm from April 1 to August 15 for Jersey Point and Emmaton. Since the X2 outflow objective of 7,100 cfs, which is not linked to the year type designation would probably control in May, and June, there would only be a gradual increase in salinity at Jersey Point and Emmaton through June that is reflective of a Critical year. Water quality at Jersey Point and Emmaton would fluctuate with the tidal and meteorological conditions potentially moving towards a 1.0 to 2.0 mmhos/cm EC range in July. Compliance with the water quality objectives at the Jersey Point and Emmaton locations typically achieves the objectives at Terminous and San Andreas Landing. This gradual increase in salinity levels would be commensurate with those experienced in years with similar hydrologic conditions as those observed in recent months.

Subject: SWRCB Water Right Decision 1641 Water Year Classification

5

Reclamation estimates that from May through August 15 a change in the water year classification from Dry to Critical in the Western Delta and Interior Delta locations in Table 2 could result in a gain of about 115,000 af, in upstream reservoir carryover storage at the end of September. Including the Delta outflow compliance in Table 3 for the same period would increase the gain in reservoir carryover storage to about 185,000 af. There could be reductions in the release from Keswick Reservoir up to about 1,000 cubic feet second in late May and June under a Critical year classification.

D-1641 requires that the number of days less than or equal to 150 mg/l chloride at Contra Costa Pumping Plant be greater than 165 days for a Dry year and 155 days for a Critical year. DWR and Reclamation do not anticipate that this objective would be a controlling criteria for the Projects under either year classification and both objectives would be met. The minimum Net Delta Outflow required from February through June (Collinsville X2 at 7,100 cfs) should be adequate to achieve the Contra Costa objective under either the Dry or Critical classification.

SWRCB recognition of the change in water year type is in the public interest. The change will provide for a water year classification reflective of the extremely dry hydrologic conditions in 2013 and allow the projects to operate in a manner that will provide the maximum benefit to critical beneficial users without unreasonably affecting other designated beneficial uses. As noted above there will be no significant impacts to agricultural or municipal uses, and the change will provide significant benefit to fisheries resources. State and federal agencies have been focused on the protection and improvement of fishery conditions in the Delta watershed, and are in the process of analyzing options for balancing project operations for the numerous different beneficial uses. Approval of the following request would result in water quality conditions in the North Delta that are consistent with the hydrology we are currently experiencing, while preserving cold water storage critical to salmon survival.

Requested Action:

Reclamation and DWR request that the SWRCB recognize the change in year classification need and act immediately. Delaying such recognition to even June 1 will significantly impair Reclamation's ability to meet cold water temperature objectives on the Sacramento River. At present, the controlling D-1641 Delta water quality objectives for the Projects that are linked to the Sacramento Valley Index are Jersey Point in Table 2, Emmaton in Table 2. In addition, Delta Outflow in Table 3, may become a controlling standard and will also impact cold water pool storage starting in the middle of June.

We believe the SWRCB may balance protection of the beneficial uses in light of the critical water year type experienced on the Sacramento River in 2013. Immediate benefits to cold water pool storage can be achieved through the Projects meeting critical water year standards for the Interior and Western Delta salinity standards in Table 2. The compliance points at issue are Sacramento River at Emmaton (Interagency Station Number D-22), San Joaquin River at Jersey

Subject: SWRCB Water Right Decision 1641 Water Year Classification

6

Point (Interagency Station Number D-15), South Fork Mokelumne River at Terminous (Interagency Station Number C-13), and San Joaquin River at San Andreas Landing (Interagency Station Number C-4).

Additional cold water pool benefits can be achieved in July through September with recognition of the critical water year type in Table 3, Water Quality Objectives for Fish and Wildlife Beneficial Uses. As noted above; Delta outflow objectives will likely control project operations in July through September, where agricultural objectives are met under a critical water year designation. A Delta outflow standard reflective of the critical water year type may produce an additional 70,000 af of cold water pool storage.

If you have any questions or would like more information regarding this notification, please contact Mr. Paul Fujitani of Reclamation at 916-979-2197 or Mr. John Leahigh at 916-574-2722.

Sincerely,

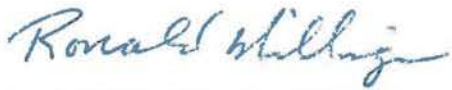

Ronald Milligan, Operations Manager
Central Valley Operations Office
U.S. Bureau of Reclamation



David H. Roose, Chief
SWP Operations Control Office
Department of Water Resources

Attachment -4

cc: Mr. Craig M. Wilson, Delta Watermaster
State Water Resources Control Board
1001 I Street
Sacramento, California 95812

Carl Wilcox
California Department of Fish and Wildlife
1416 9th Street
Sacramento, California 95814

Ms. Maria Rae
Central Valley Office Supervisor
National Marine Fisheries Service
650 Capitol Mall, Suite 5-100
Sacramento, California 95814

Ms. Kim Turner
Assistant Field Supervisor
Bay-Delta Fish & Wildlife Office
U.S. Fish & Wildlife Service
650 Capitol Mall, Suite 8-300
Sacramento, California 95814

Mr. Les Grober
State Water Resources Control Board
Division of Water Rights
1001 I Street
Sacramento, California 95812
(w/encl to each)

Attachment 1

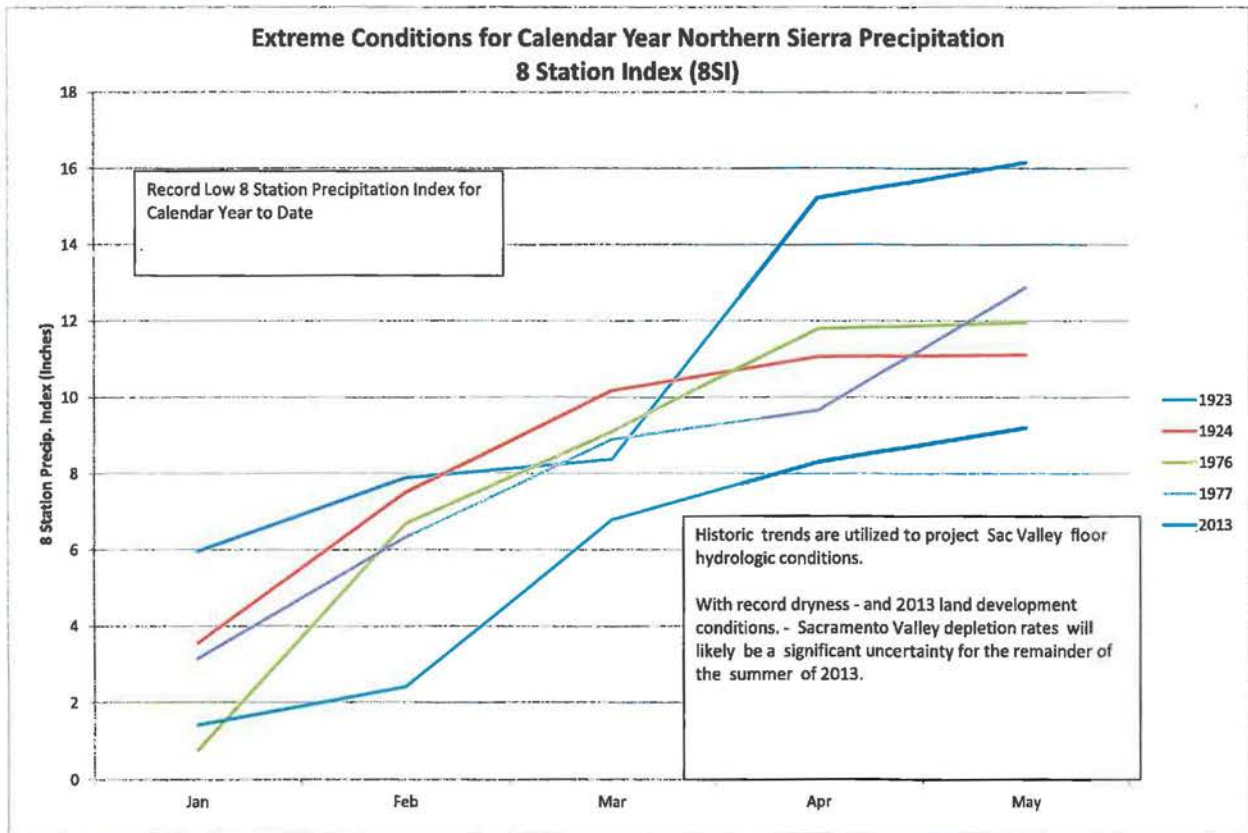

Attachment 2

Drought Severity Index by Division
Weekly Value for Period Ending MAY 18, 2013
Long Term Palmer

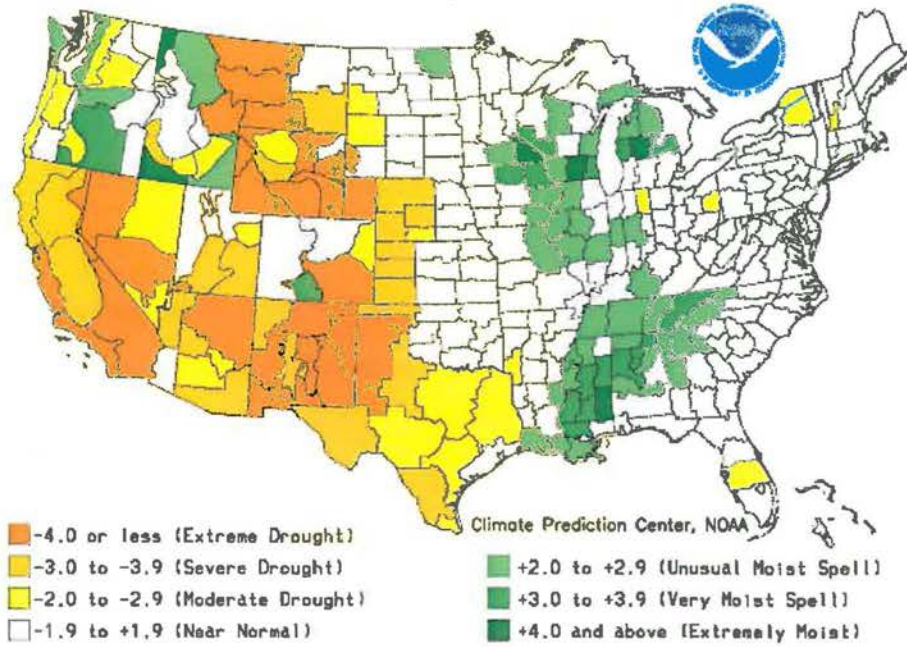

Attachment 3

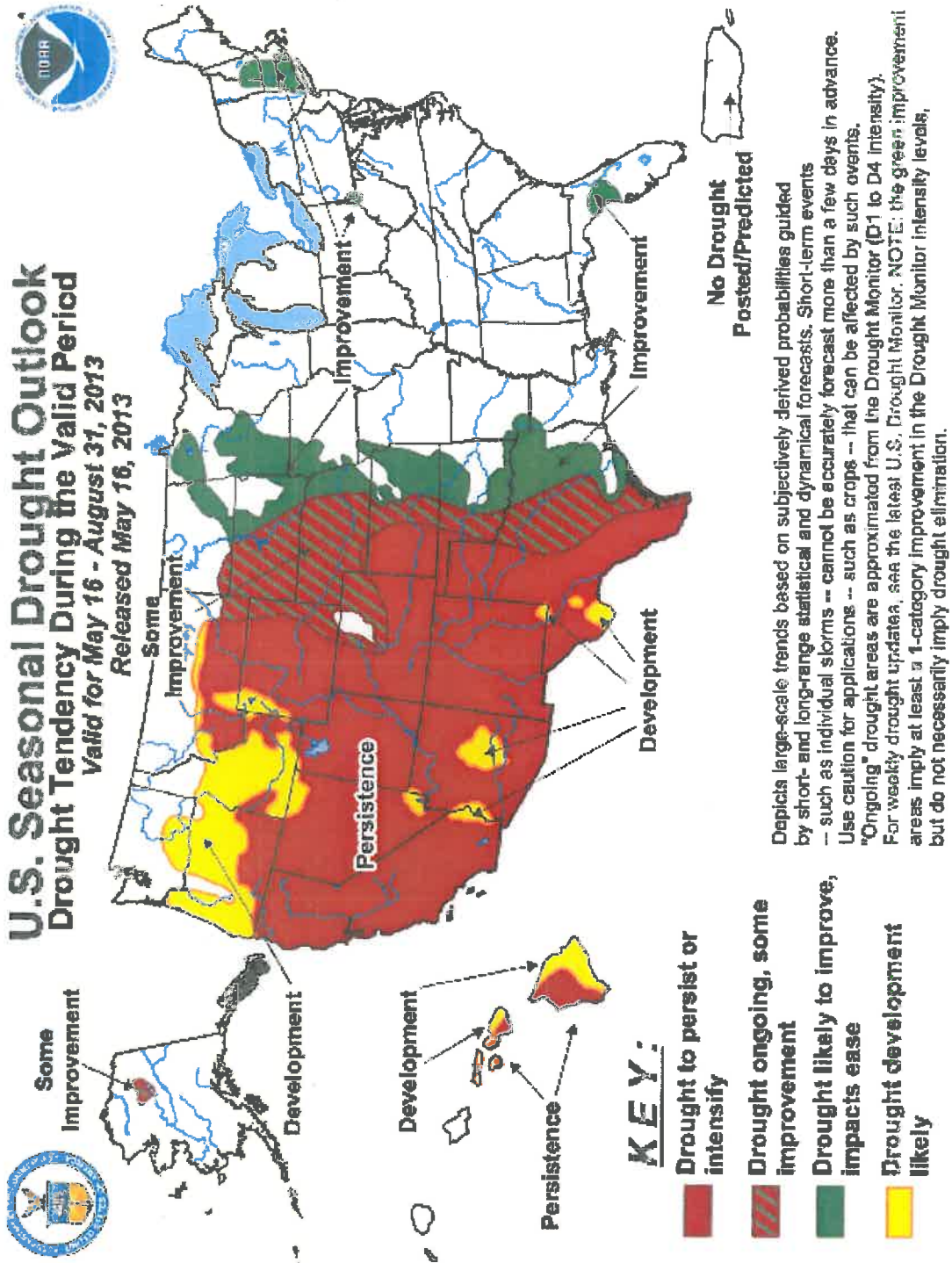

Attachment 4

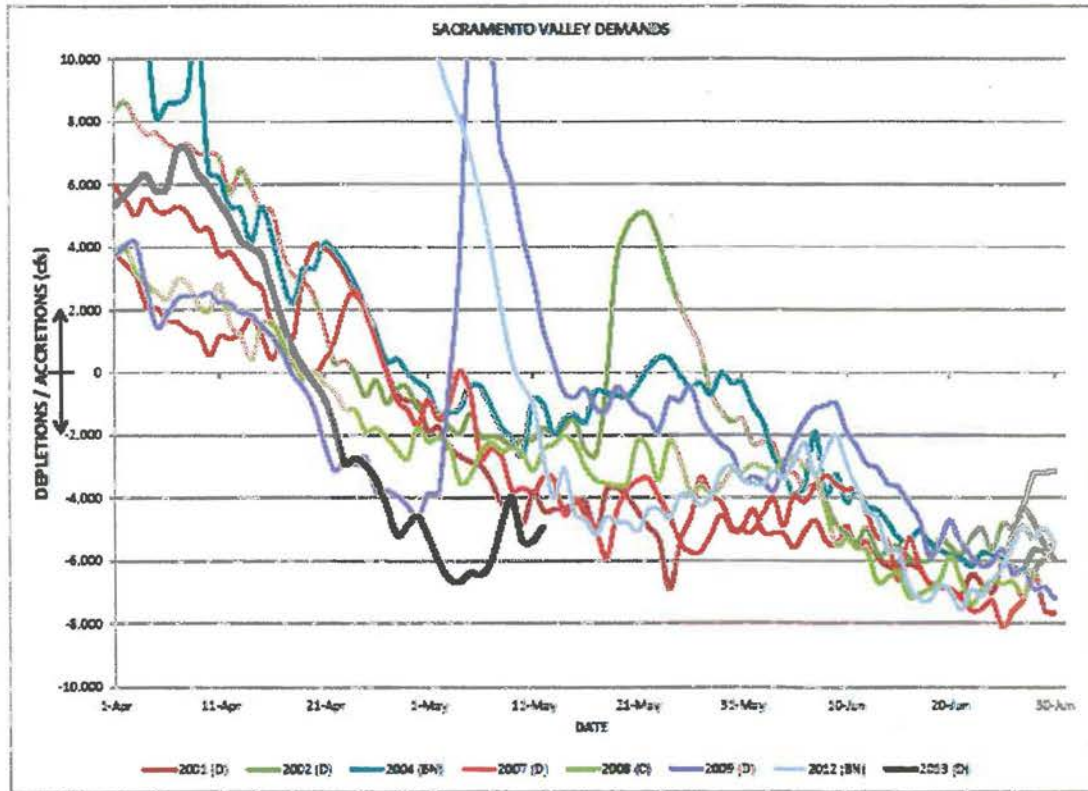

November 25, 2014

To: Barbara Vlavis
Executive Director
AquAlliance
P.O. Box 4024
Chico, CA 95927

From: Kit H. Custis 
CA PG 3942, CEG 1219, CHG 254
P.O. Box 337
Fair Oaks, CA 95628

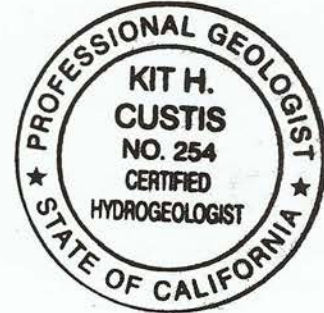
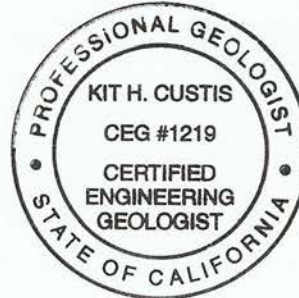

RE: Comments and Recommendations on U.S. Bureau of Reclamation and San Luis & Delta-Mendota Water Authority Draft Long-Term Water Transfer DRAFT EIS/EIR, dated September 2014

This letter provides comments and recommendations on the information provided in the September 2014 Draft Long-Term Water Transfer Environmental Impact Statement/Environmental Impact Report (Draft EIS/EIR) prepared by the U.S. Bureau of Reclamation (BoR) and San Luis & Delta-Mendota Water Authority (SLDMWA). This document evaluates the potential impacts of alternatives over a 10-year period, 2015 through 2024, for transferring Central Valley Project (CVP) and non-CVP water from north of the Sacramento-San Joaquin Delta (Delta) to CVP contractors south of the Delta. These transfers require the use of CVP and State Water Project (SWP) facilities. This Draft EIS/EIR evaluated impacts of alternatives for water transfers made available through groundwater substitution, cropland idling, crop shifting, reservoir release, and conservation. 1

This letter focuses mostly on the groundwater substitution element of the transfers for the Sacramento Valley groundwater basin and provides comments and recommendations regarding the potential impacts, technical information submitted, and monitoring and mitigation measures. Comments and recommendations are also provided regarding the biological resources, crop idling/crop shifting when those resources or activities impact or are impacted by the groundwater substitution transfers. This letter has two parts. The first part comments on the Draft Long-Term Water Transfer Draft EIS/EIR. The second part provides additional technical information on surface water-groundwater interactions that are relevant to the evaluation of potential impacts from the proposed water transfers, monitoring during the transfers and designing and implementing mitigation measures.

I. Comments and Recommendations on the Draft Long-Term Water Transfer DRAFT EIS/EIR

The Draft EIS/EIR evaluated a number of potential environmental impacts from the groundwater substitution transfers using a finite element groundwater model, SACFEM2013. The potential impacts evaluated include: groundwater levels; surface water flow; water quality; biological resources, including vegetation, wildlife and fisheries; and the associated cumulative effects and impacts. Two mitigation measures, WS-I and GW-I, are provided for monitoring and 2

mitigating potential impacts from groundwater substitution transfers. I will provide comments and recommendations on these topics following seven comments and recommendations on general issues, assumptions and methods that are used throughout the Draft EIS/EIR.

General Comments

- I. The Draft EIS/EIR has an underlying assumption that specific information on each proposed transfer will be evaluated in the future by the Bureau of Reclamation, the California Department of Water Resources (DWR), perhaps the California State Water Resources Control Board (SWRCB), and local agencies, presumably the County, or other designated local agency (Sections 1.5, 3.1.4.1-WS-1 and 3.3.4.1-GW-1). The Draft EIS/EIR relies on the results of the SACFEM2013 groundwater modeling effort to validate the conclusion of less than significant and reasonable impacts that cause no injury from the groundwater substitution transfer pumping. This conclusion is reached based on model simulation results, and assumption of implementation of mitigation measures WS-1 and GW-1. However, the Draft EIS/EIR provides only limited information on the wells to be used in the groundwater substitution transfers (see Table 3.3-3), and no information on non-participating wells that may be impacted. Information that is still needed to evaluate the potential impacts simulated by the groundwater modeling and the potential significance of the groundwater substitution transfer pumping includes, but isn't limited to:
 - a. proposed transfer wells locations that are sufficiently accurate to allow for determination of distances between the wells and areas of potential impact,
 - b. the distances between the transfer wells and surface water features,
 - c. the number of non-participating wells in the vicinity of the transfer wells that may be impacted by the pumping,
 - d. the distance between the transfer wells and non-participant wells that may be impacted by the transfer pumping, including domestic, public water supply and agricultural wells,
 - e. the number of non-participating wells in the vicinity of the transfer wells that can be expected to be pumped to provide public water supply or irrigation water during the same period as the transfer pumping,
 - f. the amount of well interference anticipated at each of the non-participating domestic, public water supply and agricultural wells in the vicinity of transfer wells,
 - g. the aquifers that the non-participating wells in the vicinity of the transfer wells are drawing groundwater from,
 - h. groundwater level hydrographs near the non-participating and participating transfer wells, to document the pre-transfer trends and fluctuations in groundwater elevations in order to evaluate the current conditions and serve as a reference for monitoring impacts from transfer pumping,
 - i. the identity and locations of wells that will be used to monitor groundwater substitution transfer pumping impacts, the aquifers these wells are monitoring, frequency for taking and reporting measurements, and the types and methods for monitoring and reporting,
 - j. groundwater level decline thresholds at each monitoring well that require actions be taken to reduce or cease groundwater substitution transfer pumping to prevent impacts from excessive drawdown, including impacts to non-participating wells, surface water features, fisheries, vegetation and wildlife, other surface structures, and regional economics.

This list addresses only the minimum of information needed about the groundwater wells and does not address other elements of the groundwater substitution transfer, which I will discuss under separate sections, including the WS-1 and GW-1 mitigation measures, the SACFEM2013 groundwater modeling effort, and stream depletion impacts.

I recommend the Draft EIS/EIR be revised to include the additional well information and monitoring requirements listed above. I recommend that mitigation measures WS-1 and GW-1 be revised to provide specific requirements for monitoring, thresholds of significance, and actions to be taken when the thresholds are exceeded.

2

2. The only maps provided by the Draft EIS/EIR that show the location of the groundwater substitution transfer wells, and the rivers and streams potentially impacted are the simulated drawdown Figures 3.3-26 to 3.3-31, which are at a scale of approximately 1 inch to 18 miles on letter size paper. These figures show clusters of wells and several rivers, creeks and canals. A few are labeled, but apparently not all of the streams and creeks evaluated for groundwater substitution impacts are shown. Figures 3.7-1 and 3.8-2 show the major rivers and reservoirs evaluated in the biological analyses, and Tables 3.7-2, 3.7-3, and 3.8-3 list up to 34 small rivers or creeks that were apparently evaluated for stream depletion using the SACFEM2013 groundwater model. Without river/stream/creek labels on the drawdown figures at a scale that allows for reasonable measurement and review, it is difficult to determine the anticipated drawdown at the 34 small rivers and creeks or other important habitat areas.

3

The Fisheries Section 3.7, and Vegetation and Wildlife Section 3.8 provide discussions of the potential impacts from groundwater substitution transfer induced stream depletion (Sections 3.7.2.1.1, 3.8.2.1.1 and 3.8.2.1.4). The Well Acceptance Criteria of Table B-1 in Appendix B of the October 2013 joint DWR and BoR document titled *Draft Technical Information for Preparing Water Transfer Proposals (DTIPWTP)* lists in the table footnotes eight major and three minor surface water features tributary to the Delta that are affected by groundwater pumping. Apparently, the Well Acceptance Criteria in Table B-1 will be applied to these eleven surface water features as part of mitigation measure GW-1. Whether the Well Acceptance Criteria will also be applied to the creeks listed in Tables 3.7-2, 3.7-3 and 3.8-2 is not specifically stated in the Draft EIS/EIR or GW-1.

4

The lack of maps with sufficient detail to see the relationship between the wells and the surface water features prevents adequate review of the Draft EIS/EIR analysis to determine whether mitigation measures WS-1 and GW-1 will be effective at mitigating pumping impacts. As I will discuss in Part 2 of this letter, the distance between a surface water feature and a pumping well is a critical parameter in estimating the rate and duration of stream depletion. Maps are needed of each seller's service area at a scale that allows for reasonably accurate measurement of distances between the groundwater substitution transfer wells and surface water features, other non-participating wells, proposed monitoring wells, fisheries, vegetation and wildlife areas, critical surface structures, and regional economic features.

5

I recommend the Draft EIS/EIR be revised to provide additional maps of each seller's service area at a scale that allows for reasonably accurate measurement of distances between the groundwater substitution transfer wells and surface water features listed in Tables 3.7-2, 3.7-3, 3.8-3 and B-1 as well as other non-listed surface water dependent features such as wetlands and riparian areas, non-participating wells, the proposed monitoring wells, wildlife areas, critical surface structures, regional economic features, and other structures that might be impacted by groundwater substitution pumping.

6

3. The Draft EIS/EIR evaluated a number of potential environmental impacts from the groundwater substitution transfers using the finite element groundwater model SACFEM2013. The results of the modeling effort were used in the assessment of the

7

potential biological resource impacts from reductions in surface water flow caused by groundwater substitution transfer pumping (pages 3.7-18 to 3.7-30, and 3.8-49 to 3.8-67). The Draft EIS/EIR assumes that SACFEM2013 model results are sufficiently accurate to justify removing most of the small creeks from a detailed effects analysis (Table 3.7-3 and 3.8-3).

Statements are given that the mean monthly reduction in the Sacramento, Feather, Yuba and American rivers will be less than 10 percent (pages 3.7-25 and 3.8-49) and that other stream requirements of flow magnitude, timing, temperature, and water quality would continue to be met. However, actual SACFEM2013 model results on anticipated changes in flow, temperature and water quality are not provided for all of the surface water features that may be potentially impacted by the groundwater substitution transfer projects. Creeks that passed a preliminary screening, Tables 3.7-3 and 3.7-4, were selected to be modeled by water year type for stream depletion that exceeds 1 cubic feet per second (cfs) and 10% reduction in mean monthly flow. Results of the modeling effort are presented in Tables 3.8-4 to 3.8-7.

7

The Draft EIS/EIR notes that not all surface water features were evaluated because some lacked sufficient historical flow data, or they were too small to model (page 3.7-20). The Draft EIS/EIR then assumes that the pumping impacts to un-modeled small surface water features are similar to nearby modeled features. No maps with sufficient detail are provided to allow for determination of the spatial relationship between the modeled and un-modeled surface water features, or the relationship between the groundwater substitution transfer wells and the modeled and un-modeled surface water features (see comment no. 2). The distance between a well and a surface water feature is a critical parameter in determining the rate and timing of surface water depletion resulting from groundwater pumping. The validity of the assumption that the un-modeled surface water features will respond similarly to the modeled is dependent on the distance between them and their respective distances to the pumping transfer well(s). I will discuss in more detail in Part 2 the importance of distance in the calculation of stream depletion.

8

The Draft EIS/EIR also provides Figures B-5 and B-6 of Draft EIS/EIR Appendix B that graph in aggregate the changes in stream-aquifer interactions, presumably equal to changes in stream flow, based on the SACFEM2013 simulations. While these graphs are interesting for several reasons, they don't provide information specific to each seller service area on flow losses expected in each river and creek. No figures are provided that show the longitudinal- or cross-sections of channel where impacts are expected, or the rate of stream depletion in each channel section. Maps with rates and times of stream depletion by longitudinal channel section are needed to allow for an adequate review of the Draft EIR/EIS conclusion of less than significant and reasonable impacts with no injury. These maps are also needed to evaluate the specific locations for monitoring potential impacts.

9

Statements are made in Section 3.7 that reductions in surface flow due to groundwater substitution pumping would be observed in monitoring wells in the region as required by mitigation measure GW-1. Thus detailed maps that show the locations of the monitoring wells and the areas of potential impact along with the rates and seasons of anticipated stream depletion are needed for each service area. These maps are also needed to allow for evaluation of the cumulative effects whenever pumping by multiple sellers can impact the same resource. Without site-specific information on expected locations and changes in flow at each potentially impacted surface water feature, it's difficult to evaluate the adequacy of any monitoring effort.

10

I recommend the Draft EIS/EIR be revised to provide additional information on the anticipated changes in surface water flow, temperature, water quality and channel geomorphology for each river, creek and surface water feature in the areas of groundwater substitution transfer pumping. In addition, I recommend that maps showing the along channel longitudinal sections, the maximum anticipated changes in flow rate, water temperature, water quality, and the timing of the maximum anticipated rate of stream depletion due to groundwater substitution transfer pumping be provided at an appropriate scale to allow for adequate measurement and review in the Draft EIS/EIR, and for use in the WS-I and GW-I mitigation monitoring programs.

11

4. The results of the SACFEM2013 simulation are used to evaluate stream depletion quantities and impacts for vegetation and wildlife resources that are dependent on surface water (Sections 3.7 and 3.8), and to determine the expected lowering of groundwater levels in the areas of transfer pumping (Section 3.3). The groundwater substitution transfer pumping simulation was run from water year (WY) 1970 to WY 2003 and assumed 12 periods of groundwater substitution transfer at various annual transfer volumes as shown in Figure 3.3-25. The apparent Draft EIS/EIR baseline for analysis of groundwater pumping impacts ends with WY 2003 because of limitations of the CalSim II surface water operations model. The CalSim II model was jointly developed by DWR and BoR and is used to determine available export capacity of the Delta. The WY 2003 time limitation was adopted in the SACFEM2013 groundwater-modeling effort apparently because of the desire to combine the simulation of groundwater impacts with estimating the timing of when groundwater substitution water could be transferred through the Delta (Section 3.3.2.1.1). The description of the SACFEM2013 modeling effort states that the volume of groundwater pumping was determined by “comparing the supply in the seller service area to the demand in the buyer service area” (page 3.3-60).

12

While this is an interesting modeling exercise, and much can be learned from it, the simulations didn’t evaluate the impacts of pumping the maximum annual amount proposed for each of the 10 years of the project. It is important that with any simulation used to analyze potential project impacts that the maximum levels of stress, pumping, proposed by the project be simulated at each of the project locations for the entire duration of the project. This is especially important whenever the simulations are used to justify the conclusion that project impacts will be less than significant, reasonable and cause no injury. Because the groundwater modeling effort didn’t include the most recent 11 years of record, it appears to have missed simulating the most recent periods of groundwater substitution transfer pumping and other groundwater impacting events, such as recent changes in groundwater elevations and groundwater storage (DWR, 2014b), and the reduced recharge due to the recent periods of drought. Without taking the hydrologic conditions during the recent 11 years into account, the results of the SACFEM2013 model simulation may not accurately depict the current conditions or predict the effects from the proposed groundwater substitution transfer pumping during the next 10 years.

13

Although the Draft EIS/EIR project description is specific on the volumes and periods of groundwater substitution transfer pumping as shown in Tables 2-4 and 2-5, the write-up of the groundwater modeling effort aggregated the volume pumped (Sections 3.3.2.4.2 and B.4.3.1.2 in Appendix B). The simulated volume of groundwater pumped doesn’t reach the maximum being requested by the project in any individual year or for all ten years (Figures B-4 in Appendix B and 3.3-25). Note, the annual groundwater substitution transfer amounts shown in Figure B-4 in Appendix B are not the same as the amounts simulated by the SACFEM2013 model as shown in Figure 3.3-25. The presentation of the SACFEM2013

14

model results in Sections 3.3.2.4.2 and B.4.3.1.2 don't tabulate or provide detailed maps by seller service area on the pumping rates, cumulative pumped volumes, pumping times and durations, or which aquifers were pumped in the simulations. The model documentation doesn't provide the maximum drawdown or the expected centers of maximum drawdown for each seller service area.

14

The documentation of the SACFEM2013 model results should also discuss the variations in potential impacts that might result from pumping transfer wells other than those simulated. If the groundwater simulation didn't pump all of the transfer wells listed in Table 3.3-3 for each seller at their maximum rate, then the modeling documentation should describe how the impacts from the simulation should be evaluated for the non-simulated transfer wells and for those well simulated at less than maximum pumping. For example, if the modeling effort provides the pumping time and distance drawdown characteristics of each well this information can be used to estimate the drawdown at different distances, pumping rates, and durations of pumping (see pages 238 to 244 in Driscoll, 1986). The Draft EIS/EIR should provide the time-drawdown and distance-drawdown hydraulic characteristics for each groundwater substitution transfer well so that non-simulated impacts can be estimated. The Draft EIS/EIR should then describe a method(s) for estimating the drawdown at different distances, rates and durations of pumping so that non-participant well owners can estimate and evaluate the potential impacts to their well(s) from well interference due to the pumping of groundwater substitution transfer well(s).

15

Because the rate of stream depletion is scaled to pumping rate and because the model documentation doesn't indicate the pumping locations, rates, volumes, times or durations that produced the pumped volumes shown in Figure 3.3-25, or the stream depletions shown in Figures B-5 and B-6 in Appendix B, there is uncertainty whether the SACFEM2013 modeling simulated the maximum rate of stream depletion for the proposed 10-year project. The annual volume of groundwater pumping shown in Figure 3.3-25 are less than the maximum requested, and pumping for a continuous 10 years was not simulated. This suggests that the stream-interaction values or stream depletion(?) shown in Figures B-5 and B-6 of Appendix B are not the maximum level of impact that might occur from the 10-year project.

16

Without information on the rate, timing and duration of the groundwater pumping, there can be no evaluation of whether the annual simulated impacts are representative of the two pumping seasons listed in Table 2-5, or just a single 3-month pumping season. Whenever the simulated annual pumping rate was greater than the single season maximum of 163,571 acre-feet (AF), two seasons of pumping are required, but the percentage in each season is unknown. If the simulated pumping time represents only one season or a mixture of the two seasons, then the simulation may not reflect the actual timing and/or duration of maximum groundwater substitution pumping impacts proposed in Table 2-5. If a simulation doesn't evaluate the project under existing conditions or simulate the maximum stress allowed by the project description, then it raises a question of whether the Draft EIS/EIR adequately evaluated the projects potential impacts. Without thorough documentation of the SACFEM2013 groundwater impact simulation, it is difficult to review and analyze the model's predictions for potential impacts from each seller's groundwater substitution transfer project, or use the model results in designing and setting impact thresholds for the groundwater monitoring required in mitigation measure GW-1.

17

I recommend the Draft EIS/EIR be revised to provide a more complete description of the SACFEM2013 groundwater modeling effort, including tabulation of the groundwater substitution pumping rates, volumes, durations,

18

and dates for each simulated well; the hydraulic characteristics of each well simulated; the aquifer(s) pumped by each simulation well; the impacts from the maximum proposed pumping, annually and during the 10-years of the proposed project; sufficiently detailed maps of the well locations in each seller's service area that non-participants and the public can use to identify any well's relationship to the groundwater substitution transfer wells and understand the potential impacts to groundwater levels. I recommend the Draft EIS/EIR provide, for each transfer well, the pumping time and distance drawdown characteristics such that drawdown for durations, distances and rates of pumping other than those simulated can be estimated. I recommend the Draft EIS/EIR also provide an explanation of why the simulation is representative of the current (2014) conditions, how the simulation can be used to assess current and future conditions, and how the simulation can be used to evaluate, monitor and set impact thresholds for future impacts from the 10-year project at the maximum groundwater substitution transfer pumping volumes listed in Tables 2-4 and 2-5.

18

5. The Draft EIS/EIR was written from the perspective of the process of transferring surface waters through the Delta. This surface water point of view has carried over into some of the analyses of impacts and mitigations for groundwater pumping. For example, the discussions of potential impacts to surface water users, fisheries, and other stream dependent biological resources are thought of as occurring "downstream" of the groundwater substitution wells. While it is correct that groundwater pumping can impact down gradient resources, pumping can also affect up gradient and lateral resources. A pumped well creates a depression in the surrounding aquifer, often referred to as a "cone of depression." Thus, the area of impact around a pumping well is not a single point, but a region whose extent is sometimes called the "area, radius or zone of influence." The length of stream affected by groundwater pumping is related to the distance between the well and the stream (Figures 16 and 29 from Barlow and Leake, 2012; Exhibits I.1 and I.2). Miller and Durnford (2005) noted that for an ideal aquifer and stream at longer durations of pumping, when the stream depletion rate approaches the well pumping rate, 50% the stream depletion occurs within a stream reach length of twice the distance between the stream and well, and 87% of the depletion occurs within a reach length of 10 times the stream to well distance. Obviously, for non-ideal aquifers and streams the length of stream depleted will vary from the ideal, but this illustrates that stream depletion caused by a pumping well is not focused at one point, but occurs along a length of stream with impacts that occur upstream and downstream from the point on the stream that is typically closest to the well.

19

Because groundwater is generally flowing, the water table or piezometric surface has a slope. This slope causes the cone of depression around a pumping well to elongate along the direction of regional flow. The elongated cone of depression is often referred to as a "capture zone" (Frind and others, 2002) and determining its extent is a basic part of a pump and treat groundwater cleanup program (USEPA, 2008a). This "capture zone" is related to stream depletion capture because the pumping well intercepts groundwater that would eventually discharge to surface water or be used by surface vegetation. If the "capture zone" extends far enough it may cross a surface water feature and induce greater seepage. However, unlike the capture needed for a contaminant plume, stream depletion can occur without the actual molecule of water that enters the well having to originate from the stream (Figure 29; Exhibit I.2).

20

The stream depletion occurs when groundwater is either intercepted before reaching the stream or seepage from the stream is increased. This water only has to backfill the change

21

in storage caused by pumping, it doesn't have to enter the well. The "capture zone" also extends upgradient to the recharge area that's the normal source of water flowing past the well. The aquifer recharge that flows past the pumping well may be derived from a wide mountain front area, it could be a section of another river that crosses the the "capture zone", or an overlying area of agricultural irrigation. In a complex hydrogeologic setting, numerical modeling that utilize particle tracking is needed to define where a pumping well is recharged and where it may deplete surface water features (Frind and others, 2002; Franke and others, 1998).

21

The concepts of a wide zone of influence and an elongated "capture zone" are important for the Sacramento Valley groundwater substitution transfers projects because the analysis and monitoring of potential pumping impacts requires a multidirectional evaluation. It can't be assumed that stream depletion impacts from pumping occur only downstream from the point on the stream closest to the pumping well. Any monitoring of the effects of groundwater substitution pumping on surface or ground water levels, rates and areas of stream depletion, fisheries, vegetation and wildlife impacts, and other critical structures needs to cover a much wider area than what is needed for a direct surface water diversion. This is a fundamental issue with the Draft EIS/EIR. The environmental analyses, monitoring requirements and mitigation measures appear to be developed without adequately considering the multidirectional, wide extent of potential impacts from groundwater substitution transfer pumping.

22

I recommend the Draft EIS/EIR be revised to address the wide extent of potential impacts for groundwater substitution transfer pumping. This should include conducting numerical modeling of the groundwater basin using particle tracking to determine which surface water features and other structures are potentially impacted by the pumping of each transfer well and to determine the extent of stream depletion along each potentially impacted surface water feature. The monitoring and mitigation measures WS-I and GW-I should also be revised to account for a wide area of potential impact from groundwater substitution transfer pumping.

23

6. The Draft EIS/EIR is written with the assumption that project specific evaluation for each seller agency will be done at a later time by the BoR and/or DWR, and at the local level (see Section 3.3.1.2.3, mitigation measure GW-I in Section 3.3.4.1, and Section 3.1 in the DTIPWRP). The Draft EIS/EIR lists in Table 3.3-1 and Table 3-1 of the DTIPWRP the Groundwater Management Plans (GMP), agreements and county ordinances that regulate the sellers at a local level. The Draft EIS/EIR discusses only two county ordinances, the Colusa Ordinance No. 615 and Yolo Export Ordinance No. 1617, one agreement, the Water Forum Agreement in Sacramento County, and one conjunctive use program, the American River Basin Regional Conjunctive Use Program. The Table 3-1 in the DTIPWRP lists short descriptions of the county ordinances related to groundwater transfers, if one exists. These descriptions don't always identify the actual ordinance number that applies to a groundwater substitution transfer, but sources for additional information are provided in the table.

24

25

The DTIPWRP (page 27) and GW-I (page 3.3-88) instructs the entity participating in a groundwater substitution transfer that they are responsible for compliance with local groundwater management plans and ordinances. Except for the brief discussion of the two ordinances, one agreement, and one conjunctive use program listed above, the Draft EIS/EIR doesn't describe the requirements of local GMPs, ordinances, and agreements listed in Tables 3.3-1 (page 3.3-8) and Table 3-1 (page 27). Thus, the actual groundwater substitution

26

transfer project permit requirements, restrictions, conditions, or exemptions required for each seller service area by BoR, DWR, and one or more County GMP or groundwater ordinance will apparently be determined at a future date. It follows that any actual monitoring requirements, mitigation measures, thresholds of significance required by BoR, DWR or local governing agencies will also be determined at a future date. The mechanism for the public to participate in the determination of the actual groundwater substitution transfer project permit requirements, restrictions, conditions, mitigation measures or exemptions isn't specified in the Draft EIS/EIR.

26

Addition information is needed on what the local regulations require for exporting groundwater out of each seller's groundwater basin. The Draft EIS/EIR needs to discuss how the local regulations ensure that the project complies with California Water Code (WC) Sections 1220, 1745.10, 1810, 10750, 10753.7, 10920-10936, and 12924 (for more detailed discussion of these Water Codes see Draft EIS/EIR Section 3.3.1.2.2). Although the Draft EIS/EIR doesn't document, compare or evaluate the requirements of all local agencies that have authority over groundwater substitution transfers in each seller service area, the Draft EIS/EIR concludes that the environmental impacts from groundwater substitution transfer pumping by each of the sellers will either be less than significant and cause no injury, or be mitigated to less than significant through mitigation measures WS-I, and GW-I with its reliance on compliance with local regulations. Because the spatial limits of groundwater substitution pumping impacts are controlled by hydrogeology, hydrology, and rates, durations and seasons of pumping, the impacts may not be limited to the boundaries of each seller's service area, GMPs, or County. There is a possibility that a seller's groundwater substitution area of impact will occur in multiple local jurisdictions, which should results in project requirements coming from multiple local as well as state and federal agencies. The Draft EIS/EIR doesn't discuss which of the multiple local agencies would be the lead agency, how an agreement between agencies would be reached, or how the requirements of the other agencies will be enforced. The Draft EIS/EIR only briefly mentions the Northern Sacramento Valley Integrated Regional Water Management Plan (IRWMP) (page 3.3-91 and -92) and doesn't mention the American River IRWMP (<http://www.rwah2o.org/rwa/programs/irwmp/>), the Yuba County IRWMP (<http://yubairwmp.org/the-plan-irwmp/content/irwmp-plan>), or the Yolo County IRWMP (<http://www.yolowra.org/irwmp.html>). The Draft EIR/EIS doesn't provide information on the water management requirements of the IRWMP covering each seller service area or how the groundwater substitution transfers will be accounted for in the IRWMP process.

27

Because the Draft EIS/EIR requires that each individual transfer project meet the requirements of Water Code sections listed above, and because it assumes that each of the sellers will separately comply with all federal, state and local regulation, GMPs, IRWMPs, ordinances or agreements, the Draft EIS/EIR should provide an analysis of how these local regulations, GMPs, ordinances or agreements will ensure each seller's project achieves the goals of no injury, less than significant and reasonable impacts. Each seller's project analysis should identify what future analyses, ordinances, project conditions, exemptions, monitoring and mitigation measures are required to ensure that each of the seller's project meets or exceed the goals of the Draft EIS/EIR.

28

I recommend the Draft EIS/EIR be revised to include a discussion and comparison of the local regulations, GMPs, IRWMPs, ordinances and agreements that govern each of the seller's proposed groundwater substitution transfers. I recommend each analysis demonstrate that each seller's project will meet or exceed the environmental protection goals of the Draft EIS/EIR. I recommend an analysis that compares local and regional management plans,

29

ordinances, regulations, and agreements with the monitoring and mitigation measures in the Draft EIS/EIR to identify any additional mitigation measures needed to ensure compliance with local, regional, state and federal regulations. I recommend an analysis that includes: (1) a discussion on how the local lead agency will be determined; (2) how multiagency jurisdictions will be enforced; (3) how conflicts between different local, regional, state and federal regulatory jurisdictions will be resolved; and (4) how public participation will occur.

29

7. The Draft EIS/EIR provides only one groundwater elevation map of the Sacramento Valley groundwater basin, Figure 3.3-4, which shows contours from wells screened from a depth greater than 100 feet to less than 400 feet below ground surface (bgs) (>100 to < 400 feet bgs) and only for the northern portion of the proposed groundwater substitution transfer seller area. The Draft EIS/EIR doesn't provide maps showing groundwater elevations, or depth to groundwater, for groundwater substitution transfer seller areas in Placer, Sutter, Yolo, Yuba, and Sacramento counties.

30

The DWR provides on a web site a number of additional groundwater level and depth to groundwater maps at:

http://www.water.ca.gov/groundwater/data_and_monitoring/northern_region/Groundwater_Level/gw_level_monitoring.cfm#Well%20Depth%20Summary%20Maps.

For example, there are maps that show the change in groundwater levels from the spring of 2004 to spring of 2014 for shallow screened wells (<200 feet bgs), intermediate wells (>200 to <600 feet bgs), deep wells (>600 feet bgs), and well screened in the >100 to < 400 feet bgs interval. In addition, the DWR web site has a series of well depth summary maps for Butte, Colusa, Glenn, and Tehama counties, and the Redding Basin that show the density of wells screened at less than 150 feet bgs, and between 150 and 500 feet bgs, along with contours of the depth to groundwater in the summer of 2013. There are also numerous other groundwater elevation contour maps on DWR's web page, going back to 2006. Historical and recent groundwater elevation and depth contours maps for Placer, Sutter, Yolo, Yuba, and Sacramento counties may be available from the groundwater substitution transfer sellers, other water agencies in those counties, the IRWMP documents, or technical reports on groundwater management (for example, Northern California Water Association, 2014a, b, and c).

31

Historic change and current groundwater contour maps are critical to establishing an environmental baseline for the groundwater substitution transfers. This information is needed to evaluate the impacts from groundwater substitution transfers because it establishes the present groundwater basin conditions and document the changes and trends in groundwater levels in the last 10-plus years, which were not simulated by the SACFEM2013 modeling.

32

Information on the depth to shallow groundwater is critically important because of the analysis of impacts to vegetation and wildlife in Section 3.8 assumed, based on the results of the SACFEM2013 model, that the current depth to shallow groundwater is greater than 15 feet bgs for most of the Sacramento Valley groundwater basin (page 3.8-32). Because the simulation showed a condition of greater than 15 feet depth to groundwater, the Draft EIS/EIR concluded that impacts from lowering of the shallow water table as a result of the groundwater substitution transfer pumping would be less than significant (page 3.8-47).

33

This assumption however appears to conflict with the DWR shallow well depth summary maps (DWR, 2014a) that show contours of the depth to groundwater in wells less than 150 feet bgs in the summer 2013. These maps show extensive areas around the Sutter Buttes

34

and to the north were the depth to groundwater is less than 10 feet and 20 feet (Exhibit 2.1). These maps also show extensive areas where the depth to groundwater is less than 40 feet, a depth significant to some tree species such as the valley oak (page 3.8-32). There is also a recent trend of lower groundwater levels in a number of areas in the Sacramento Valley as shown on the DWR 2004 to 2014 groundwater change maps for shallow, intermediate, deep aquifer zones available from the web site listed above (DWR, 2014b). Exhibit 2.1 has a composite map of the shallow zone well depth maps and traces of the shallow zone 2004 to 2014 groundwater elevation change contours.

34

These groundwater elevation, depth and changes in elevation maps are important for documenting baseline groundwater conditions. The recent trend of decreased groundwater levels should be included in the analysis of groundwater substitution pumping impacts because the drawdowns shown in Figures 3.3-26 to 3.3-31 will interact with existing conditions, and may cause additional long-term decreases in groundwater levels. The Draft EIS/EIR's assessment of the impacts from groundwater substitution transfer pumping to existing and future wells, fisheries, vegetation and wildlife, and surface structures should factor in these recent trends in groundwater levels and not rely solely on SACFEM2013 model simulations that ended in 2003. In addition, the hydrographs in Appendix E that show the SACFEM2013 model results should identify wells near the selected 34-hydrograph locations where groundwater level measurements have been taken and show these actual groundwater levels on the hydrographs. Currently the public is left with the task of finding groundwater level data near the 34 selected hydrograph locations and then validating the simulation results by making comparisons between the simulated water levels and the actual water levels. This model validation task should be part of the Draft EIS/EIR.

35

I recommend the Draft EIS/EIR be revised to include maps of recent groundwater levels and depths to groundwater along with changes in groundwater levels and depths for at least the last 11 years for all of the counties where the seller agencies propose a groundwater substitution transfer project. I recommend that the Draft EIS/EIR be revised to provide additional verification of the SACFEM2013 model results by comparing them to measured groundwater levels in the vicinity of the 34 selected modeling hydrograph locations. I also recommend the hydrographs of actual water level measurements in the vicinity be included on the simulation hydrographs, so that the public can review the accuracy of the simulation. I recommend contour maps showing the current depth to groundwater be made from actual shallow groundwater measurements and that these contours be shown on maps of the surface water features identified and evaluated in Draft EIS/EIR Sections 3.3-Groundwater, 3.7-Fisheries (Table 3.7-3), and 3.8-Vegetation and Wildlife (Table 3.8-3). I recommend that the SACFEM2013 simulation drawdowns be combined with the current (2014) groundwater elevations for each groundwater substitution transfer aquifer to show the cumulative impacts of the 10-year project on existing groundwater elevations.

36

Groundwater Model SACFEM2013

A finite element groundwater model, SACFEM2013, was used to evaluate the potential for changes in groundwater levels and stream depletion from groundwater substitution transfer pumping during the 10-year period of the project. The results of the simulations were used to evaluate the impacts to fisheries, vegetation and wildlife (Section 3.7 and 3.8). Section 3.3.2.1 discusses the use of the model for estimating regional groundwater level declines due to groundwater substitution pumping. Figures 3.3-26 to 3.3-31 provide simulated changes in

37

groundwater elevation or head for three intervals, up to 35 feet bgs, 200 to 300 feet bgs, and 700 to 900 feet bgs. Figures 3.3-32 to 3.3-40 and Appendix E provide hydrographs of model simulations for 34 selected locations shown on the simulated groundwater elevation change maps. Sections 3.7.2.1.1, 3.7.2.1.3, 3.7.2.4.1, 3.8.2.1.1, 3.8.2.1.4, and 3.8.2.4.1 provide discussion on the potential impacts of groundwater substitution transfer pumping on fisheries, vegetation and wildlife resources from a drop in the shallow groundwater table and depletion of stream flows.

The SACFEM2013 model was set up to simulate transient flow conditions from WY 1970 to WY 2010 (page 3.3-60). Historic data from 1970 to 2003 were used to estimate the potential impacts from groundwater substitution transfers during the 10-year period of the project. The simulation terminated at 2003 because that was the last simulation period available for the CalSim II model, a planning model designed to simulate operations of the CVP and SWP reservoirs and water delivery systems. Additional SACFEM2013 model documentation is given in Appendix D, which provides information on the model gridding, layering, assumptions and calculation methods. Several of the model designs and parameters selected likely influenced the model's ability to predict future impacts from the 10-year groundwater substitution transfer project. Those include: the time period of the model, the assumptions about the amount and frequency of groundwater substitution pumping, the model's nodal spacing, estimates of aquifer properties, the number of streams simulated, streambed parameters, and specified-flux boundaries. There are at least two other groundwater simulation models developed for the Sacramento Valley, a U.S. Geological Survey model, USGS-CVHM (Faunt, ed., 2009) and a DWR-C2VSim model (Brush and others, 2013a and 2013b).

A comparison between the SACFEM2013 and these two other models provides an interesting assessment of how these three models estimated the hydrogeologic character and conditions of the Sacramento Valley. A comparison also demonstrates that there is no one correct groundwater model, that models with different parameter distributions can achieve reasonable calibration. With models of differing hydrogeologic characteristics, the predictions of future impacts by each model should be expected to differ. Determining which of the models accurately predicts future impacts requires the validation of each model's prediction with new field data. The Draft EIS/EIR mitigation measures for groundwater substitution transfer pumping shouldn't assume that the SACFEM2013 model results are all that is needed to demonstrate no injury and less than significant impacts from the proposed project. Validation of the model-based conclusion of no impacts requires collection of new field data and comparison to simulation predictions throughout and beyond the 10-year project.

A comparison of portions of the SACFEM2013 simulation for the Draft EIS/EIR with the two other models is given below.

8. *Period of Modeled Historic Groundwater Conditions* – Although the model simulation period ended in 2003, the Draft EIS/EIR indicates that the model was run to 2010, but the results were not provided. From the model write-up it is unknown whether the latest groundwater elevations were a factor in the modeling effort. The simulation hydrographs in Appendix E terminate in 2004. Apparently, the hydrologic conditions for the latest 10 years are not included because the Draft EIS/EIR doesn't discuss how the model simulations agree with the current baseline conditions. Specifically, the change in groundwater elevation between 2004 and 2014 as documented by DWR (2014b) in a series of three maps. I've

37

38

provided in attached Exhibits 3.1 to 3.3 maps that are composites of DWR's 2004 to 2014 groundwater change maps with Draft EIS/EIR Figures 3.3-29, 3.3-30 and 3.3-31, the SACFEM2013 1990 hydrologic conditions simulations of drawdown by zone. The 1990 hydrologic condition was selected for comparison because the sequence of groundwater pumping events is the closest match to the actual pumping requested in the Draft EIS/EIR. Note that the depth intervals of the two sets of maps don't exactly coincide, but they are generally grouped as shallow, intermediate and deep aquifers.

Exhibits 3.1 to 3.3 show that the simulated changes in groundwater elevation from the 10-year groundwater substitution transfer project appear to widen the existing groundwater depressions. The pumping depression southwest of Orland will expand to the east and northeast, as will the depression in the Williams area. A pumping depression will develop in the Live Oaks area and to the east. In the southeastern Sacramento area, the pumping depression from the 10-year project will apparently extend southeastward beyond the limits of the Sacramento Valley transfer project boundary. Combining the existing areas of recent sustained groundwater drawdown with the additional drawdown from the groundwater substitution transfer pumping could slow the recovery of groundwater elevations. The 10-year project pumping east of Orland may connect the two existing groundwater depressions around Orland and Chico to create one large depression. Because the DWR 2004 to 2014 groundwater change maps don't extend completely to the southern portions of the Sacramento Valley groundwater substitution transfer area in Placer, Sutter, Yolo, Yuba, and Sacramento counties, no evaluation can be made about the impact of 10 years of groundwater substitution transfer pumping on existing groundwater conditions in those or adjacent areas.

I recommended the Draft EIS/EIR be revised to discuss how the SACFEM2013 simulations incorporate the changes in groundwater level from 2004 to 2014 in assessing the potential impacts from the proposed 10 years of groundwater substitution transfer pumping. I recommended this discussion include evaluation of the rate and duration of groundwater level recovery that factors in the existing (2014) groundwater levels. I also recommend the Draft EIS/EIR be revised to discuss how during the 10 years of project transfers through the Delta will be made with a CalSim II model that's only current to the year 2003.

9. *Simulation Pumping Volume and Frequency* - The model simulated a series of groundwater pumping events in 12 out of the 34 years of simulation (page 3.3-60). The logic of a multiyear, variable hydrology simulation was that it allowed for evaluation of the cumulative effects of pumping in previous years (page 3.3-61). Figure 3.3-25 shows the simulated periods of groundwater substitution transfer pumping. The 1990 simulation period most closely matches the multiyear pumping being requested by the 10-year project. The 1990 simulation period included groundwater pumping 7 out of 10 years, with pumping values ranging from approximately 95,000 acre-feet per year (AFY) to approximately 262,000 AFY, as measured from Figure 3.3-35. Note the actual pumping rates, volumes, and pumping durations were not provided in the simulation documentation. Apparently, none of the modeled groundwater substitution pumping simulation periods was given the actual maximum groundwater substitution pumping value of 290,495 AFY as calculated from Table 2-5. The time-weighted annual average pumping rate for the 1990 simulation period is approximately 126,900 AF, as measured from Figure 3.3-35. This represents approximately 44% of the maximum pumping rate requested in the Draft EIS/EIR ($126,900 \text{ AF} / 290,495 \text{ AF} = 0.437$). Therefore the SACFEM2013 Draft EIS/EIR simulations may only represent a portion of the project's potential impacts from groundwater substitution transfer pumping.

38

39

I recommend the Draft EIS/EIR be revised to discuss how the SACFEM2013 simulations provide a full and accurate estimation of the potential impacts from the groundwater substitution transfer pumping throughout the 10-year project. I also recommend the Draft EIS/EIR be revised to include SACFEM2013 simulations at the maximum requested annual volume of 290,495 AF for each of the 10 years of pumping.

39

10. *Simulation Grid Size* - The SACFEM2013 documentation states that the grid used for groundwater substitution transfer simulations has 153,812 nodes and 306,813 elements (page D-3 of Appendix D). The model nodal spacing varies from 410 feet to 3,000 feet, with an approximate nodal spacing of 1,640 feet along streams and flood bypasses. While this nodal spacing is reasonable for regional groundwater simulations, the results of the simulations may not provide the detail needed to evaluate drawdown interference between the groundwater substitution transfer wells and adjacent non-participating wells. Information is needed on the locations of the groundwater substitution transfer wells and the adjacent non-participating wells in order to determine whether the current simulation grid spacing can accurately estimate well interference. The Draft EIS/EIR analysis of groundwater substitution pumping impacts should be based on an appropriate model grid spacing to establish accurate maximum thresholds for well interference caused by the transfer well pumping. The Draft EIS/EIR should provide sufficient information that an owner of a non-participating well can determine accurately the maximum anticipated increase in drawdown at their well during the 10 years of groundwater substitution transfer pumping. Whether this amount of increased drawdown is significant at each non-participating well is a matter of the current well design and groundwater conditions at each well. The Draft EIS/EIR should establish values for the maximum allowable well interference drawdown from groundwater substitution transfer pumping, which should be based on the costs and inconvenience of lowering the water level. The Draft EIS/EIR should establish the economic costs and level of injury that are reasonable for a non-participating well owner to assume and will keep the impacts from the 10-year project in compliance with the no injury rule as required by WC Section 1706, 1725 and 1736 (Section 1.3.2.3).

40

I recommend the Draft EIS/EIR be revised to discuss how the maximum thresholds for water level drawdown due to well interference from groundwater substitution transfer pumping will be established for non-participating wells, and provide a process for assigning a threshold to each non-participating well, along with monitoring requirements and specific mitigation measures should the threshold be exceeded. The Draft EIS/EIR also should be revised to provide the threshold values for well system repair costs used in set the maximum allowable well interference drawdown, along with the documentation and analysis of why the well interference drawdown and cost thresholds are considered reasonable and result in no injury to non-participating well owners, and comply with the Water Code.

11. *Simulation Hydrogeologic Parameter Values* - The SACFEM2013 model was developed with seven layers of varying thickness that extend from the shallow water table to the base of fresh water. The USGS-CVHM model has ten layers, while the DWR-C2VSim model has 3 layers. All of the models assume that the uppermost layer, layer 1, was unconfined and the lower layers are confined aquifer. The hydrogeologic parameters values differ for each of these models as shown in a summary table in Exhibit 4.1. Both the CVHM and C2VSim models divided the Central Valley in to 21 subregions (Figure 3, Brush and others, 2013a; Exhibit 4.4). The SACFEM2013 doesn't use subregions from the Sacramento Valley model. As discussed below, the SACFEM2013 appears to use the same distribution of the

41

horizontal hydraulic conductivity, K_h , for all model layers (Figure D-4 of Appendix D). Both the CVHM and the C2VSim models appear to have more varied hydraulic conductivity distributions than SACS2013.

Development of the SACS2013 simulations used horizontal hydraulic conductivity values derived from the well logs of large-diameter irrigation wells. Shallow and low-yielding wells, less than 100 gallons per minute (gpm), and domestic-type wells were not used (page D-12 of Appendix D). The values of specific capacity (gallons per minute per foot of drawdown) from the DWR well completion reports were used to estimate transmissivity around a well using an empirical equation for confined aquifer developed from Jacob's modified non-equilibrium equation (see equation 8 page D-13 and Appendix 16D of Driscoll, 1986 in Exhibit 4.6). Transmissivity was converted to K_h by assuming the aquifer thickness was equal to the length of the well screen interval. These well K_h values were then averaged using a geometric mean with surrounding wells within a critical distance of 6 miles. The results of the geometric mean averaging were then gridded using a kriging to produce K_h values across the modeled area (Figure D-4 in Appendix D). The transmissivity of each model layer was then calculated at each node by multiplying the kriged geometric mean value of K_h by the aquifer layer thickness. The vertical hydraulic conductivity, K_v , was calculated by assuming a uniform $K_h:K_v$ ratio of 50:1 for layer 1 and 500:1 for layers 2 to 7.

The CVHM model (Faunt, ed., 2009) used the percentage of coarse-grained material from well logs and boreholes as the primary variable in a sediment texture analysis of the Central Valley, which was divided into nine textural provinces and domains (Figures A10 to A14; Exhibits 4.7a to 4.7i). The Sacramento Valley has three textural domains, Redding, eastern, and western Sacramento domains (page 30, Faunt, ed., 2009). The coarse-grained fraction was correlated to horizontal (K_h) and vertical (K_v) conductivity (page 154, Faunt, ed., 2009). The K_h values were estimated using kriging and a weighted arithmetic mean, a type of power mean, whereas the K_v value estimates used either a harmonic or geometric mean. Faunt (ed., 2009) notes that the arithmetic mean is most influenced by the coarser-grained material, whereas the fine-grained material more heavily weights both the harmonic and geometric means. Figure C14 (Exhibit 4.7j) shows the relationship between the percentage of coarse-grained deposits and hydraulic conductivity for the different types of means. For the Sacramento Valley the texture-weighted power-mean value was -0.5, a value midway between the harmonic and geometric means (Table C8, Exhibit 4.3).

Table C8 lists the end member hydraulic conductivity values used in the CVHM model with those for the Sacramento Valley ranging from 670 feet/day (ft/day) for coarse-grained to 0.075 ft/day for fine-grained. The table also lists field and laboratory values of K_h and K_v for coarse and fine-grained deposits. The Redding textural domain has the highest percentage of coarse-grained material of the three in Sacramento Valley, a mean of 39 percent, with the western portion becoming coarser with depth (page 30, Faunt, ed., 2009). The western and eastern Sacramento domains are finer-grained, with the eastern mean at 32 percent coarse-grained deposits, and the western mean at 25 percent. Figure A15B(A?) (Exhibit 4.7k) shows the cumulative distribution of kriged sediment textures for each layer of the CVHM model for the Sacramento Valley. Figures A12A to A12E (Exhibits 4.7c to 4.7g) show the distribution of coarse-grained deposits in CVHM groundwater model layers 1, 3, Corcoran Clay, 6 and 9 for the Sacramento and San Joaquin Valleys. Isolated coarser-grained deposits that occur in layer 1 are associated with the Sacramento River, distal parts of fans from the Cascade Range and northern Sierra Nevada, and the American River (page 30, Faunt, ed., 2009; Figure A14, Exhibit 4.7i). Although the texture maps, Figures A12A to A12E of CVHM, and the hydraulic conductivity distribution map of Figure D4 of SACS2013, show different characteristic of each model's hydraulic conductivity, they can be compared by

their visual complexity. The CVHM texture also varies by model layer, whereas the SACFEM2013 apparently applied the same Kh distribution to each layer. The CVHM western and eastern Sacramento domains appear to have smaller coarse-grained areas than the SACFEM2013 higher hydraulic conductivity areas (Figures A12, C14 and A15 in Exhibits 4.7c, 4.7j, and 4.7k versus D4 in Appendix D). Figure 12E (Exhibit 4.7g) shows layer 9 with high percentages of coarse-grained deposits that have higher Kh values (Figure C14) in the western parts of the Redding (10) and northern western portion of the western Sacramento (11) province. Whereas Figure D4 of SACFEM2013 shows these same areas as having the lowest Kh values, suggesting finer-grained textures dominate.

The C2Vsim model divided the Sacramento Valley into seven subregions, as did the USGS-CVHM model. Like the USGS model, hydraulic conductivity varies with the three model layers for the Sacramento Valley. The spatial variability of the Kh and Kv values for the C2VSim model is greater than with the SACFEM2013 model (compare Figures 34 and 35 from Brush and others, 2013a in Exhibits 4.8a to 4.8f to Figures D4 of Appendix D). Table 5 of Brush and others, 2013a (Exhibit 4.2) shows the range of model parameters for the saturated groundwater portion of the C2VSim model. Kh values range from 2.2 ft/day to 100 ft/day, and Kv from 0.005 ft/day to 0.299 ft/day. The highest Kh value for the C2VSim model is less than for SACFEM2013 (100 ft/day vs 450 ft/day), while the lowest values are lower (0.005 ft/day vs <0.1 ft/day).

I recommend the Draft EIS/EIR discuss the uncertainty in aquifer hydraulic parameter estimations for the groundwater substitution transfer pumping simulations and the sensitivity of the model results to the uncertainty in the groundwater hydraulic parameters. I recommend the Draft EIS/EIR discuss how the uncertainty in hydraulic conductivity parameters influences: (1) estimates of potential stream depletion (Section 3.3), (2) evaluations of fisheries impacts (Section 3.7), (3) evaluations of vegetation and wildlife impacts (Section 3.8), and (4) the screening procedures that removed a number of the small streams from further environmental impact analysis (Table 3.7-3 and 3.8-3).

12. *Simulation Groundwater Storage Parameters* - The SACFEM2013 simulations assigned to the upper unconfined model layer 1 a uniform specific yield (Sy) value of 0.12 (dimensionless) (page D-14 in Appendix D; Exhibit 4.1). For the confined model layers 2 to 7 a uniform specific storage, Ss, value of 6.5×10^{-5} per foot (ft) was used (page D-14 of Appendix D; Exhibit 4.1). Both the CVHM and C2VSim simulations used a range of values of Sy and Ss that were more variable than SACFEM2013 (Exhibits 4.1, 4.8n, and 4.8o). The CVHM simulation used a range of Sy and Ss values, (CVHM Table C8, Exhibits 4.3). The CVHM simulation also used a range of Ss values for coarse-grain elastic and fine-grained elastic and inelastic deposits to simulating subsidence from groundwater pumping. The C2VSim simulations used a range of Sy values for model layer 1 and separate ranges of Ss values for layers 2 and 3 (C2VSim Table 5, Exhibits 4.2; Exhibits 4.8g to 4.8i). The C2VSim and CVHM models assigned a range of coefficients for elastic (Sce) and inelastic (Sci) deposits used in simulating subsidence (Exhibits 4.1, 4.8j to 4.8m). Note, the Ss values are multiplied by the aquifer thickness at each model node at to obtain the dimensionless value of storativity (S) for confined aquifers ($S = Ss \times \text{thickness}$), which is similar to the dimensionless Sy parameter for an unconfined aquifer.

I recommend the Draft EIS/EIR discuss the uncertainty in aquifer storage parameter estimations for the groundwater substitution transfer pumping simulations and the sensitivity of the model results to the uncertainty in the groundwater storage parameters. I recommend the Draft EIS/EIR discuss how

41

42

uncertainty in groundwater storage parameters influences: (1) estimates of potential stream depletion (Section 3.3), (2) evaluations of fisheries impacts (Section 3.7), (3) evaluations of vegetation and wildlife impacts (Section 3.8), and (4) the screening procedures that removed a number of the small streams from further environmental impact analysis (Table 3.7-3 and 3.8-3).

42

13. *Simulation River and Stream Parameters* - All three models simulated the interactions between the groundwater and streams or rivers. The rate and direction of movement of water between streams and shallow groundwater is governed by the vertical hydraulic conductivity of the streambed, K_{vb} , thickness of the streambed, m , the wetted perimeter of the stream, w , and the difference in elevation between groundwater table and stream. The hydraulic parameters of a streambed are combined into a term called conductance, C , which is calculated as the product of K_{vb} times the wetted perimeter divided by the streambed thickness ($C = [K_{vb} \times w]/m$).

The SACFEM2013 simulations assigned all eastern streambeds draining from the Sierra Nevada a K_{vb} value of 6.56 ft/day (2 meters/day), except the Bear River and Big Chico Creek, whose values were unstated (page D-7 of Appendix D). For all western streambeds draining the Coast Ranges, a higher value of K_{vb} at or above 16.4 ft/day (5 meters/day) was assigned. Figure 3.3-24 in the Draft EIS/EIR shows the SACFEM2013 groundwater boundary and the simulated rivers and streams. This map may not be showing all of the small streams evaluated in the simulation based on the streams listed in Tables 3.7-3 and 3.8-3 (also see general comment no. 2).

43

The streambed K_{vb} values used in CVHM simulation are shown in Figure C26 (Exhibit 5.3). The values of K_{vb} for the Sacramento Valley varying from approximately 0.04 ft/day to 5.6 ft/day are shown in Figure C26. Results of the CVHM simulation of surface water-groundwater interactions, gains and losses, from 1961 to 1977 are compared to measured and simulated stream gauge values in Figures C19A and C19B (Exhibits 5.4a and 5.4b).

The C2VSim simulations also used varying values for streambed K_{vb} ranging from 0 to 44 ft/day with a mean of 1.8 ft/day and lake bed K_{vb} of 0.67 ft/day (page 100, Brush and others, 2013a; Exhibit 5.1). Simulated streambed conductance values are shown in Figure 40 of Brush and others, 2013a (Exhibit 5.2).

I recommend the Draft EIS/EIR discuss the uncertainty in streambed parameter estimations for the groundwater substitution transfer pumping simulations and the sensitivity of the model results to the uncertainty in the hydraulic characteristics of the streambeds. I recommend the Draft EIS/EIR discuss how uncertainty in the hydraulic characteristics of the streambeds influences: (1) estimates of potential stream depletion (Section 3.3), (2) evaluations of fisheries impacts (Section 3.7), (3) evaluations of vegetation and wildlife impacts (Section 3.8), and (4) the screening procedures that removed a number of the small streams from further environmental impact analysis (Table 3.7-3 and 3.8-3).

14. *Groundwater Flow Between Sub-regions* - Of the three previously discussed regional groundwater models for the Sacramento Valley, only the reports for the C2VSim simulation provided information on the volume of groundwater that flows laterally among groundwater subregions. The C2VSim simulation results show that groundwater flow between subregions has changed significantly in some areas (Figures 81A to 81C of Brush and others, 2013a and Figure 39 of Brush and others, 2013b; Exhibits 6.1a to 6.1c and 6.2). The SACFEM2013 simulations results presented in the Draft EIS/EIR don't provide information on the exchange between subregion areas used in simulations by the USGS (Faunt, ed.,

44

2009) and DWR (Brush and others, 2013a and 2013b). Therefore, the flow of groundwater between the subregions and/or counties of the 10-year project's groundwater substitution transfer sellers wasn't evaluated for potential impacts on neighboring areas. The loss or gain of groundwater from neighboring subregions should be evaluated in the Draft EIS/EIR.

Accounting for subsurface flow among subregions is an important part of the water balance because it is measures of the amount of impact that groundwater pumping in one subregion has on it's neighboring subregions. The subsurface inter-basin movement of groundwater is an important element in the analysis of the environmental impacts from the 10-year groundwater substitution transfer projects because the groundwater substitution transfer pumping by sellers in one region can have a significant impact on the groundwater levels, storage and stream depletion in adjacent regions.

The C2VSim simulations calculated the volume of groundwater that flowed between the subregions and presented the results for three decades, 1922-1929, 1960-1969, and 2000-2009, and for the total simulation period, 1922-2009. Tables 10 through 13 (Brush and others, 2014a; Exhibits 6.3a to d) provide the sum of inter-region groundwater flow for each model subregion, but not the individual values of flow among adjoining subregions. Figures 81 and 39 (Exhibits 6.1a to 6.1c and 6.2) give the simulated annual volume of inter-region flow for the three decades and from 1922 to 2009. An estimate of a portion of the long-term changes in groundwater storage in each subregion can be made by comparing the change in annual volume and flow direction between sub-regions.

For example, in the 1922 to 1929 simulation period subregion 9 (Sacramento-San Joaquin Delta) received 81,000 AFY of groundwater flow from adjoining subregions 6, 8, 10 and 11 (Exhibit 6.1a). By 1969 the simulation shows that subregion 9 was still receiving a small volume, 2,000 AFY, of groundwater flow from subregion 6, but losing approximately 56,000 AFY to subregions 8, 10, and 11 (Exhibit 6.1b). A change in groundwater storage from 1929 to 1969 in the Delta of 135,000 AFY; from a plus 81,000 AFY to a minus 54,000 AFY. For 2002-2009, the simulation shows that the Delta still receiving a small volume, 4,000 AFY, of groundwater flow from subregion 6, but now losing 137,000 AFY to subregions 8, 10 and 11 (Exhibit 6.1c). A loss in storage in the Delta of 214,000 AFY from 1929. The 2000-2009 simulation period shows that subregion 8 is receiving a large portion of the groundwater flow out of the Delta, 112,000 AFY, a reversal in groundwater flow direction and a cumulative annual loss to the Delta from 1922-1929 of 147,000 AFY. Subregion 8 in turn loses 17,000 AFY of groundwater flow to subregion 7 in 2000-2009, and receives 123,000 AFY from subregion 11 (Exhibit 6.1c). A reversal of 1922-1929 when subregion 8 received 1,000 AFY from subregions 7 and gave 1,000 AFY to subregion 11.

The 10-year transfer project proposes under the groundwater substitution to pump up to approximately 75,000 AFY from subregions 7 and 8, Table 2-5. This additional pumping will likely cause additional groundwater to flow from the subregion 9, the Delta, and subregion 11 into subregion 8, and eventually to subregion 7. Similar shifts in direction and annual volumes of groundwater flow have occurred with the other Central Valley subregions. The changes direction and volume of flow between the Delta and surrounding subregions appear to be the largest shift in groundwater flow for in Sacramento Valley area.

I recommend the Draft EIS/EIR be revised to evaluate the subsurface flows between subregions in Sacramento Valley due to the proposed groundwater substitution transfer pumping. I recommend the Draft EIS/EIR be revised to include groundwater model simulations that account for the rates, volumes, times, and changes in direction of groundwater flow between the seller pumping areas and the surrounding non-participating regions. I recommend the Draft

EIS/EIR also analysis the short- and long-term impacts from the changes in subregional groundwater flow caused by the 10-year transfer project.

44

Mitigation Measure WS-I

15. The purpose of mitigation measure WS-I as stated in Draft EIS/EIR Section 3.1.4.1 is to mitigate potential impacts to CVP and SWP water supplies from stream depletion caused by groundwater substitution transfer pumping. The stream depletion factor (BoR-SDF) is imposed by the BoR and DWR because they *will not move transfer water if doing so violates the no injury rule* (page 3.1-21). The no injury rule is discussed in Section 1.3.2.3 and cites CA WC Sections 1725, 1736 and 1706. The language from WC 1736 that also requires transfers to not result in unreasonable effects to fish, wildlife, or other instream beneficial uses is discussed in the subsequent Section 1.3.2.4.

Draft EIS/EIR Sections 3.1.2.4.1 (page 3.1-15) and 3.1.6.1 (page 3.1-21) discuss the impacts from groundwater substitution transfers on surface water. On page 3.1-16 the Draft EIS/EIR states that groundwater recharge, presumably greater because of groundwater substitution pumping, occurring during higher flows would decrease flow in surface waterways. During periods of high flow, the decrease in surface flow won't affect water supplies or the ability to meet flow or quality standards. The document also states that if groundwater recharge occurs during dry periods, presumably occurring when groundwater substitution transfers are needed, groundwater recharge would decrease flows and affect BoR and DWR operations. BoR and DWR would then need to either decrease Delta exports or release additional flows from surface storage to meet the required standards. These statements are followed by seemingly conflicting statements that:

45

Transfers would not affect whether the water flow and quality standards are met, however, the actions taken by Reclamation and DWR to meet these standards because of instream flow reductions due to the groundwater recharge could affect CVP and SWP water supplies. (page 3.1-16)

Increased releases from storage would vacate storage that could be filled during wet periods, but would affect water supplies in subsequent years if the storage is not refilled. (page 3.1-17)

The potential for the reduction in surface water storage to eventually cause reductions in streamflow and water quality isn't clearly addressed in the Draft EIS/EIR.

Overall, the increased supplies delivered from water transfers would be greater than the decrease in supply because of streamflow depletion; however, the impacts from streamflow depletion may affect water users that are not parties to water transfers. On average, the losses due to groundwater and surface water interaction would result in approximately 15,800 AF of water annually compared to the No Action/No Project Alternative, or approximately a loss of 0.3 percent of the supply. (page 3.1-18)

In a period of multiple dry years (such as 1987-1992), the streamflow depletion causes a 2.8 percent reduction in CVP and SWP supplies, or 71,200 AF. (page 3.1-18)

46

To reduce these effects, Mitigation Measure WS-I includes a streamflow depletion factor to be incorporated into transfers to account for the potential water supply impacts to the CVP and SWP. Mitigation Measure WS-I would reduce the impacts to less than significant. (page 3.1-18)

Additional information on the requirements of WS-I appears to be contained in the October 2013 joint DWR and BoR document titled *Draft Technical Information for Preparing Water Transfer Proposals* (DTIPWTP) because the discussion in that document's Section 3.4.3

on estimating the effects of transfer operations on streamflow says that a default BoR-SDF of 12 percent will be applied “unless available monitoring data analyzed by Project Agencies supports the need for the development of a transfer proposal site-specific SDF” (page 33). The document also states that:

Although real time streamflow depletion due to groundwater substitution pumping for water transfers cannot be directly measured, impacts on streamflow due to groundwater pumping can be modeled. Project Agencies have applied the results from prior modeling efforts to evaluate potential groundwater transfers in the Sacramento Valley to establish an estimated average streamflow depletion factor (SDF) for transfers requiring the use of Project Facilities.

46

I have several comments on this analysis of stream depletion impacts and mitigation measure WS-1:

- a. Sections 2.3.2.2 and 2.3.2.3 discuss potential groundwater substitution and crop idling transfers and the limitations on the timing of the transfers. Transfers typically occur from July to September, but could also occur from April to June if conditions in the Delta allow for transfer. Surface water to be used in groundwater substitution and crop idling transfers would be stored during April to June if the condition of the Delta is unacceptable for transfer.

My understanding of the BoR-SDF in mitigation measure WS-1 is that at the same time transfer surface waters are flowing towards the Delta, a portion of that water is assigned to the waterway to “offset” or compensate for stream depletion caused by groundwater substitution pumping. The Draft EIS/EIR doesn’t seem to address the issue of how to compensate for groundwater substitution pumping impacts occurring before or after the transfer water flows to the Delta, the long-term losses caused by the pumping in subsequent years, and cumulative impacts from multiple years of pumping by all sellers. Yet the Draft EIS/EIR acknowledges that stream depletion is cumulative and a cumulative increase in depletion can be significantly greater than with a single event (Section 4.3.1.2 in Appendix B). The SACFEM2013 simulation shows that stream depletion will continue for a number of years after the groundwater substitution pumping event (Figures B-4, B-5 and B-6 in Draft EIS/EIR Appendix B). Mitigation measure WS-1 doesn’t appear to fully address how mitigation will occur for stream depletion impacts from groundwater substitution pumping during entire duration of the impact.

47

I recommend mitigation measure WS-1 be revised to clearly address how reductions in stream flows caused by groundwater substitution transfer pumping will be mitigated to less than significant for all of the times when stream depletion is occurring, including the time before and after the water is physically transferred; long-term impacts; and cumulative impacts from multiple sellers over multiple years of participating in groundwater substitution transfers.

- b. Although mitigation measure WS-1 doesn’t state that its implementation is linked to the October 2013 DTIPWTP (that linkage is part of mitigation measure GW-1), the DTIPWTP discusses the use of the BoR-SDF in the methodology for determining the amount of water available for groundwater substitution transfer, and the effects of the groundwater substitution pumping on streamflow in Section 3.4 (page 31). Item 5 on page 31 gives the formula for using four steps in determining the amount of transferable water, one of which is subtraction of the

48

estimated streamflow reduction. Section 3.4.3 states on page 33 of the DTIPWTP that:

Although real time streamflow depletion due to groundwater substitution pumping for water transfers cannot be directly measured, impacts on streamflow due to groundwater pumping can be modeled. Project Agencies have applied the results from prior modeling efforts to evaluate potential groundwater transfers in the Sacramento Valley to establish an estimated average streamflow depletion factor (SDF) for transfers requiring the use of Project Facilities.

Project Agencies will apply a 12 percent SDF for each project meeting the criteria contained in this chapter unless available monitoring data analyzed by Project Agencies supports the need for the development of a transfer proposal site-specific SDF.

Project Agencies are developing tools to more accurately evaluate the impacts of groundwater substitution transfers on streamflow. These tools may be implemented in the near future and may include a site-specific analysis that could be applied to each transfer proposal.

Mitigation measure WS-1 states on page 3.1-21 that:

The exact percentage of the streamflow depletion factor will be assessed and determined on a regular basis by Reclamation and DWR, in consultation with buyers and sellers, based on the best technical information available at that time. The percentage will be determined based on hydrologic conditions, groundwater and surface water modeling, monitoring information, and past transfer data.

48

From these statements it appears that: (1) the BoR, DWR and other Project Agencies have previously analyzed the amount of stream depletion caused by past groundwater substitution transfers, and (2) the default of 12% BoR-SDF may not be applied to groundwater substitution during the 10 years of transfers because transfer-specific studies will be needed. The Draft EIS/EIR doesn't provide information or cite references on the previous modeling and/or monitoring efforts to determine the correct stream depletion factor. It also doesn't provide specific information on the method(s) and review process to be used in implementing mitigation measure WS-1, or what additional assessments are needed to determine the "exact percentage" for the BoR-SDF. Mitigation measure WS-1 appears to require that the assessment, the calculation methodology, and determination of the correct BoR-SDF be done at a future time. The Draft EIS/EIR doesn't state whether other regulatory agencies and/or the public will have an opportunity in the future to review and comment on the methodology and determination of the "exact percentage" of the BoR-SDF for each groundwater substitution transfer seller. The Draft EIS/EIR also doesn't state whether other regulatory agencies and/or public comments will be considered by BoR and DWR in determining the BoR-SDF percentage.

The statement that real time stream depletion can't be directly measured contradicts other statements in the Draft EIS/EIR, requirements of mitigation measure GW-1, and the scientific literature. For example: Section 3.5 of the DTIPWTP states that one of the objectives of the monitoring plan is to:

Determine the extent of surface water-groundwater interaction in the areas where groundwater is pumped for the transfer. (page 34)

49

This objective is in the project's monitoring program therefore it appears to

indicate that some method is available for monitoring the surface water-groundwater interactions, not just the pre-pumping model simulations. The Fisheries (3.7) and Vegetation Wildlife (3.8) sections of the Draft EIS/EIR appear to state that flow reductions in surface waterways caused by groundwater substitution pumping will be monitored. Paragraphs similar to the ones given below state that monitoring wells are part of the mitigation measure for surface waters:

49

In addition, flow reductions as the result of groundwater declines would be observed at monitoring wells in the region and adverse effects on riparian vegetation would be mitigated by implementation of Mitigation Measure GW-1 (See Section 3.3, Groundwater Resources), because it requires monitoring of wells and implementing a mitigation plan if the seller's monitoring efforts indicate that the operation of the wells for groundwater substitution pumping are causing substantial adverse impacts. The mitigation plan would include curtailment of pumping until natural recharge corrects the environmental impact. Therefore, the impacts to fisheries resources would be less than significant in these streams. (pages 3.7-26 and 3.7-56)

50

In addition, the Proposed Action has the potential to cause flow reductions of greater than ten percent on other small creeks where no data are available on existing streamflows to be able to determine this. The impacts of groundwater substitution on flows in small streams and associated water ways would be mitigated by implementation of Mitigation Measure GW-1 (see Section 3.3, Groundwater Resources) because it requires monitoring of wells and implementing a mitigation plan if the seller's monitoring efforts indicate that the operation of the wells for groundwater substitution pumping are causing substantial adverse impacts. The mitigation plan would include curtailment of pumping until natural recharge corrects the environmental impact. Implementation of these measures would reduce significant effects on vegetation and wildlife resources associated with streams to less than significant. (pages 3.8-51, 3.8-58 and 3.8-68)

All of these statements seem to contradict the statement in mitigation measure WS-1 that stream depletion can't be measured in real time. Although the Draft EIS/EIR doesn't provide the technical method(s) for determining surface water flow using monitoring in groundwater wells, it's reliance on mitigation measure GW-1 to ensure that streamflows are adequate implies that a method is available. Because WS-1 and GW-1 both have one of the same objectives, to mitigation streamflow losses due to groundwater substitution pumping, the mitigation measure are linked. Thus, the real time monitoring of groundwater intended to mitigate streamflow losses under GW-1 might also facilitate real time monitoring of streamflow needed for WS-1. I'll provide in Part 2 of this letter some additional discussion and references to scientific literature on studies and methods for measuring stream seepage and stream depletion caused by groundwater pumping.

51

I recommend the Draft EIS/EIR be revised to clearly discuss the methods available for determining the value of the BoR-SDF for each groundwater substitution transfer well. I recommend the Draft EIS/EIR be revised to discuss the procedure for Project Agency review and approval, along with process for review and comment by other public agencies and the public. I recommend the Draft EIS/EIR be revised to discuss the methods and results of prior BoR-SDF determinations. I recommend the Draft EIS/EIR be revised to define the data needed to

determine the “exact percentage” of stream depletion from groundwater substitution pumping during the 10-year transfer project, the technical method(s) that will be used to calculate the amount of stream depletion and the BoR-SDF, and the method(s) for monitoring surface water flow losses and verifying the effectiveness of the BoR-SDF and mitigation measure WS-I.

51

- c. Section 3.4.1 of the DTIPWTP discusses calculation of baseline groundwater pumping for groundwater substitution transfers. Baseline groundwater pumping and stream depletion reduction are part of the four-step process for determining the amount of transferable water (page 31). Water transfer sellers wanting to use groundwater substitution pumping are requested to submit information to:

Identify all wells that discharge to the contiguous surface water delivery system within which a well is proposed for use in the transfer program, and

The amount of groundwater pumped monthly during 2013 for each well that discharges to the contiguous surface water delivery system.

Section 3.4.2 discusses measuring groundwater pumping provided for groundwater substitution transfers and states that:

Sellers should provide pumping records from all wells that discharge to a contiguous surface water delivery system used in groundwater substitution transfers. (page 32)

The requirement that the groundwater transfer pumping baseline and metering of transfer pumping be conditioned on the water being discharged to the *contiguous surface water delivery system* suggests that if the groundwater substitution pumping discharges to a non-contiguous surface water or directly to a field that the establishment of a pre-transfer pumping baseline and transfer metering aren't required. Is that the case? If it is the case, then how is the amount of transferable water determined whenever the groundwater substitution transfer pumping doesn't discharge to a *contiguous surface water delivery system*? If the pre-transfer baseline pumping is removed from the calculation, does that increase or decrease the amount of transferable water and how does that change the BoR-SDF requirement? Is metering required for groundwater substitution transfer wells that don't discharge to a *contiguous surface streams water delivery system*? If not, how will measurement of transferred water and the required amount of the BoR-SDF be verified? All of these factors are relevant because they are linked to mitigation measure WS-I through the DTIPWTP four-step process to determine the amount of transferrable water. The amount of transferrable water incorporates the BoR-SDF to prevent injury and reduce groundwater substitution pumping stream depletion impacts to less than significant.

52

I recommend the Draft EIS/EIR be revised to provide a discussion of how the baseline for pre-transfer groundwater pumping will be determined and how metering of all groundwater substitution transfer pumping for wells will be done regardless of whether the well discharges to a contiguous surface water delivery system. I recommend the Draft EIS/EIR be revised to discuss how the BoR-SDF will be determined, monitored, and it's effectiveness verified for all groundwater substitution transfer wells regardless of whether the well discharges to a contiguous surface water delivery system.

Mitigation Measure GW-1

16. The Draft EIS/EIR has only two mitigation measures that apply to the groundwater substitution transfers, WS-1 and GW-1. GW-1 is the principle mitigation measure for the 10-year transfer project's Draft EIS/EIR and is discussed in Section 3.3.4.1. The requirements contained in the October 2013 joint DWR and BoR *Draft Technical Information for Preparing Water Transfer Proposals* (DTIPWTP) and its 2014 Addendum are included in GW-1 by reference. The monitoring and mitigation measures of GW-1 are generally statements of objectives and requirements for development in the future monitoring and mitigation plans that are approved by BoR and perhaps DWR. GW-1 doesn't appear to provide any future opportunity for review and comment by parties that may be impacted by the groundwater substitution transfers such as the non-participating well owners, the public, or other regulatory agencies. GW-1 has statements such as:

The monitoring program will incorporate a sufficient number of monitoring wells to accurately characterize groundwater levels and response in the area before, during, and after transfer pumping takes place. (page 3.3-88)

The monitoring program will include a plan to coordinate the collection and organization of monitoring data, and communication with the well operators and other decision makers. (page 3.3-89)

Potential sellers will also be required to complete and implement a mitigation plan. (page 3.3-89)

To ensure that mitigation plans will be feasible, effective, and tailored to local conditions, the plan must include the following elements: (page 3.3-90 and 3.3-91)

- *A procedure for the seller to receive reports of purported environmental or effects to non-transferring parties;*
- *A procedure for investigating any reported effect;*
- *Development of mitigation options, in cooperation with the affected parties, for legitimate significant effects*
- *Assurances that adequate financial resources are available to cover reasonably anticipated mitigation needs.*

Reclamation will verify that sellers adopt and implement these measures to minimize the potential for adverse effects related to groundwater extraction. (page 3.3-91)

GW-1 does have some specifics on requirements for the frequency of groundwater level monitoring, such as weekly monitoring during the transfer period (page 3.3-89). Requirements for the frequency of reporting are less specific. Summary tables to BoR during and after transfer-related groundwater pumping, and a summary report sometime after the post-project reporting period. The project reporting period extends through March of the year following the transfer (page 3.3-90). The requirement for only a single year of groundwater monitoring appears to be insufficient given the duration of the simulated pumping impacts (see Figure B-5 in Appendix B). Other reporting requirements such as groundwater elevation contour maps are given as "should be included" rather than "shall be included" (page 3.3-90).

The BoR should already have monitoring and mitigation plans and evaluation reports based on the requirements of the DTIPWTP for past groundwater substitution transfers, which likely were undertaken by some of the same sellers as the proposed 10-year transfer project. The Draft EIS/EIR should provide these existing BoR approved monitoring programs and mitigation plans as examples of what level of technical specificity is required

to meet the objectives of GW-1 that include: (1) *mitigate adverse environmental effects that occur*; (2) *minimize potential effects to other legal users of water*; (3) *provide a process for review and response to reported effects*; and (4) *assure that a local mitigation strategy is in place prior to the groundwater transfer* (page 3.3-91). In addition, examples of periodic reporting tables and final evaluation reports should be provided to demonstrate the effectiveness of the GW-1 process at preventing or mitigating impacts from the groundwater substitution transfer pumping. Other deficiencies in GW-1 have been discussed above in my comments nos. 1, 2, 3, 5, 6 and 15, and below in comment no. 18.

I recommend the Draft EIS/EIR be revised to include specifics on additional requirements that must be part of mitigation measure GW-1 including: (1) required distances from wells and surface water features, and aquifer zones for groundwater elevation monitoring; (2) the duration of the required post-transfer monitoring that accounts for the effects of the 10 years of pumping; (3) specifics requirements on scale and detail for maps, figures and tables needed to document groundwater substitution pumping impacts; and (4) specific threshold for changes in groundwater elevation, groundwater quality and subsidence that will be considered significant. I recommend the Draft EIR/EIS be revised to provide existing BoR approved monitoring and mitigation plans and reports for past groundwater substitution transfers as examples of the types of technical information necessary to ensure no injury with less than significant impacts and appropriate mitigations. I recommend the Draft EIS/EIR be revised to provide specifics on how the public will be able to participate in the BoR and DWR approval and revision process for the 10-year transfer project monitoring and mitigation plans. I also recommend the Draft EIS/EIR revise GW-1 to include the issues discussed elsewhere in my comments nos. 1, 2, 3, 5, 6, 15 and 18.

53

Water Quality

17. The Draft EIS/EIR discusses water quality in Section 3.2, but focuses on potential impacts to surface waters. Discussions of impacts from groundwater substitution transfer pumping on groundwater quality are given in Section 3.3 (pages 3.3-33 to 3.3-35). The Draft EIS/EIR discusses the potential for impacts to groundwater quality from migration of contaminants as a result of groundwater substitution pumping, but provides only a general description of the current condition of groundwater quality. Section 3.3 gives the following statements on water quality:

Groundwater Quality: Changes in groundwater levels and the potential change in groundwater flow directions could cause a change in groundwater quality through a number of mechanisms. One mechanism is the potential mobilization of areas of poorer quality water, drawn down from shallow zones, or drawn up into previously unaffected areas. Changes in groundwater gradients and flow directions could also cause (and speed) the lateral migration of poorer quality water. (pages 3.3-59 and 3.3-60)

Degradation in groundwater quality such that it would exceed regulatory standards or would substantially impair reasonably anticipated beneficial uses of groundwater; or (page 3.3-61)

Additional pumping is not expected to be in locations or at rates that would cause substantial long-term changes in groundwater levels that would cause changes to groundwater quality. Consequently, changes to groundwater quality due to increased pumping would be less than significant in the Redding Area Groundwater Basin. (page 3.3-66)

54

Inducing the movement or migration of reduced quality water into previously unaffected areas through groundwater pumping is not likely to be a concern unless groundwater levels and/or flow patterns are substantially altered for a long period of time. Groundwater extraction under the Proposed Action would be limited to short-term withdrawals during the irrigation season. Consequently, effects from the migration of reduced groundwater quality would be less than significant. (page 3.3-83)

Groundwater extracted could be of reduced quality relative to the surface water supply deliveries the seller districts normally receive; however, groundwater quality in the area is normally adequate for agricultural purposes. Distribution of groundwater for municipal supply is subject to groundwater quality monitoring and quality limits prior to distribution to customers. Therefore, potential impacts to the distribution of groundwater would be minimal and this impact would be less than significant. (page 3.3-84)

The Draft EIS/EIR notes that several groundwater quality programs are active in the seller regions (pages 3.3-6 to 3.3-10). No maps are provided that show the baseline groundwater quality and known areas of poor or contaminated groundwater. Groundwater quality information on the Sacramento Valley area is available from existing reports by the USGS (1984, 2008b, 2010, and 2011) and Northern California Water Association (NCWA, 2014c). The Draft EIS/EIR doesn't compare the known groundwater quality problem areas with the SACFEM2013 simulated drawdowns to demonstrate that the proposed projects won't draw in or expand the areas of known poor water quality. The Draft EIS/EIR analysis doesn't appear to consider the impacts to the quality of water from private wells. Pumping done as part of the groundwater substitution transfer may cause water quality impacts from geochemical changes resulting from a lowering the water table below historic elevations, which exposes aquifer material to different oxidation/reduction potentials and can alter the mixing ratio of different quality aquifer zones being pumped. Changes in groundwater level can also alter the direction and/or rate of movement of contaminated groundwater plumes both horizontally and vertically, which may expose non-participating wells to contaminants they would not otherwise encounter.

As noted above in my general comment no. 7, the DWR well depth summary maps for the northern Sacramento Valley show that there are potentially thousands of private well owners in and adjacent to the proposed project areas of the groundwater substitution drawdown. Exhibit 2.1 has a composite map of DWR's northern Sacramento Valley well depth summary maps (DWR, 2014a) for the shallow aquifer zone, wells less than 150 feet deep and the areas of groundwater decline from 2004 to 2014 (DWR, 2014b). Exhibit 7.1 has a table that summarizes the range of the number of shallow wells by county that lie within the areas of groundwater decline from 2004 to 2014. In my general comment no. 5, I discussed the concept of capture zones for wells and the need for groundwater modeling using particle tracking to identify the areas where a well receives recharge. Particle tracking to define a well capture zone(s) can also be used to determine if known zones or areas of poor or contaminated water will migrate as a result of the groundwater substitution transfer pumping. Particle tracking can also identify private and municipal wells that lie within the capture zone of a groundwater substitution transfer well and might experience a reduction in water quality from the transfer pumping. Particle tracking can identify locations where mitigation monitoring of groundwater quality should be conducted to quantify changes in groundwater quality.

Even though there are already a number of shallow wells impacted by historic groundwater level declines, the Draft EIS/EIR reaches the conclusion that the groundwater substitution transfer pumping will not cause injury or a significant impact to groundwater quality. This

54

55

56

conclusion is reached in part because the assumed beneficial use of groundwater substitution pumped water is agricultural, or urban, where the quality of water delivered is monitored by an urban water agency. Only these two beneficial uses are assumed even though Table 3.2-2 lists numerous other uses for waters in the seller service areas. The Draft EIS/EIR doesn't provide sufficient information on existing water quality conditions in the Sacramento Valley to allow for evaluation of potential geochemical changes that groundwater substitution pumping might cause. The Draft EIS/EIR sets a standard of significance in degradation of groundwater quality that requires contaminants exceed regulatory standards or impair reasonably anticipated beneficial uses (page 3.3-61). This standard of significance ignores the regulatory requirements of the Water Quality Control Basin Plans (Basin Plans) (http://www.waterboards.ca.gov/centralvalley/water_issues/basin_plans/index.shtml). The Draft EIS/EIR only briefly discusses the role of the Basin Plans in maintaining water quality (page 3.2-7). In addition this water quality threshold of significance likely violates the State Water Resources Control Board Resolution No. 68-16, titled *Statement of Policy with Respect to Maintaining High Quality of Waters in California*, that states:

“Whenever the existing quality of water is better than the quality established in policies as of the date on which such policies became effective, such existing high quality will be maintained until it has been demonstrated to the state that any change will be consistent with the maximum benefit to the people of the state, will not unreasonably affect present and anticipated beneficial use of such water and will not result in water quality less than that prescribed in the policies.”

“The nondegradation policy of the State Board (Resolution No. 68-16) applies to surface and groundwaters that are currently better quality than the quality established in ‘adopted policies.’ In terms of water quality objectives, the basin plans are the source of adopted policies.”

I recommend the Draft EIS/EIR be revised to document the known condition of the groundwater quality in the Sacramento Valley and Redding Basin and include available maps. I recommend that this assessment evaluate the potential impacts from migration of known areas of poor groundwater quality that could be further impaired or spread as a result of the groundwater substitution transfer pumping. I recommend a groundwater quality mitigation measure be provided for evaluation the existing water quality in wells (assuming owner cooperation) within and adjacent to known areas of poor groundwater quality that lie within and adjacent to the simulated groundwater transfer drawdown areas, especially those that lie within the capture zone. I recommend the groundwater quality mitigation measure include: (1) procedures for sampling wells, (2) methods of water quality analysis, (3) a QA/QC program, (4) standards and threshold for water quality impairment consistent with public health requirements and Basin Plan beneficial uses and SWRCB Resolution No. 68-16, (5) provisions for independent oversight and review by regulatory agencies and affected well owners, and (6) specific reporting and notification requirements that keep the owners of non-participating wells, the public, and regulatory agencies informed. I recommend the groundwater quality mitigation measure include provisions for modification and/or treatment of non-participating wells should the quality of water delivered be significantly altered by groundwater substitution transfers. I recommend the groundwater quality mitigation measure be in effect during the 10-year period of transfer pumping and the following recovery period until groundwater flows return to the pre-project condition. I recommend the Draft EIS/EIR also

require a funding mechanism for implementing the groundwater quality mitigation measures for the entire 10-year duration of the groundwater substitution transfers and the recovery period. I recommend the costs of the groundwater quality mitigation monitoring be the responsibility of the project proponents, not the non-participating wells owners or the public. These costs should include reimbursement of any costs incurred by regulatory agency oversight and costs incurred by non-participating well owners.

56

Subsidence

18. The impacts of subsidence due to groundwater substitution transfer pumping are discussed in Section 3.3. Section 3.3.1.3.2 discusses groundwater-related land subsidence and notes that Global Positioning System (GPS) surveying is conducted by DWR every three years at 339 elevation survey monuments throughout the northern Sacramento Valley (page 3.3-28). In addition, eleven extensometers, as shown in Figure 3.3-11, monitor land subsidence. Figure 3.3-11 provides graphs of the subsidence for five of the eleven extensometers; no information is provided on the results on the GPS surveys. Mitigation measure GW-1 also incorporates by reference the October 2013 DTIPWRP and its 2014 Addendum. The DTIPWRP doesn't add any additional monitoring or mitigation requirements for subsidence, stating that areas that are susceptible to land subsidence may require land surface elevation surveys, and that the Project Agencies will work with the water transfer proponent to develop a mutually agreed upon subsidence monitoring program (pages 34 and 37). Apparently the Draft EIS/EIR expects that the mutually agreed upon subsidence monitoring programs will be a future mitigation measure. The Draft EIS/EIR doesn't discuss how other regulatory agencies or the public will participate in the reviewing and commenting on any future subsidence mitigation measure.

57

The Draft EIS/EIR relies on local GMPs and county ordinances to prevent impacts from subsidence, but doesn't discuss any specific monitoring or mitigation measures for each proposed groundwater substitution transfer pumping area (page 3.3-7). The Draft EIS/EIR acknowledges that subsidence has occurred in the past in portions of the Sacramento Valley in Yolo County (page 3.3-29), and that the Redding groundwater basin has never been monitored (page 3.3-17). Yet only a qualitative assessment of potential project impacts was done by comparing SACFEM2013 simulated groundwater drawdowns with areas of existing subsidence and by comparing estimates of pre-consolidated heads/historic low heads (page 3.3-61).

58

The Draft EIS/EIR relies on the mitigation measure GW-1 to prevent and remedy any significant impacts from subsidence. The requirements in mitigation measure GW-1 for subsidence impacts specify that the BoR will determine, apparently in the future and only when mutually agreed upon, the "strategic" monitoring locations throughout the transfer area where land surface elevations will be measured at the beginning and end of each transfer year (page 3.3-89). When the land surface elevation survey indicates an elevation decrease in an area, more subsidence monitoring will be required, which could include: (1) extensometer monitoring, (2) continuous GPS monitoring, or (3) extensive land-elevation benchmark surveys conducted by a licensed surveyor. More extensive monitoring will be required for areas of documented historic or higher susceptibility to land subsidence (page 3.3-89). The Draft EIS/EIR concludes that with these subsidence monitoring mitigation measures of GW-1, impacts will be reduced to less than significant (page 3.3-66).

59

Exhibits 8.1a to 8.1c provides composite maps using as a base DWR's *Spring 2004 to 2014 Change in Groundwater Elevations* (DWR, 2014b) for the shallow (less than 200 feet bgs), intermediate (200 to 600 feet bgs) and the deep (greater than 600 feet bgs) aquifer

zones in the northern Sacramento Valley. A map of the natural gas pipelines in the Sacramento Valley (Exhibit 8.6) has been scaled and combined with Exhibits 8.1a to 8.1c. Exhibit 8.2 depicts on DWR's (2014b) intermediate zone change in groundwater elevation map, the locations of extensometers and the GPS subsidence grid (from Figure 6 in DWR, 2008; Exhibit 8.4), and the known subsidence area southeast of Williams and into Yolo County (from Draft EIS/EIR Figure 3.3-11)).

The subsidence area in Yolo County isn't fully shown on the DWR's 2014 groundwater elevation change maps, but is shown in the composite maps (Exhibits 8.1a to 8.1c). These exhibits and Exhibit 8.2 show that the western line of extensometers lies along the eastern edge of the intermediate zone of greatest groundwater elevation change, and aligns with the central axis of the mapped changes in groundwater elevation in deeper aquifer zone. The extensometers don't appear to lie within the area of known subsidence southeast of Williams and into Yolo County (Figure 3.3-11). The GPS subsidence grid network does extend across eastern portion of the known subsidence area southeast of Williams and into Yolo County depicted in Figure 3.3-11 and the groundwater elevation change in the intermediate aquifer zone southwest of Orland (Exhibit 8.2).

Although there are several areas in the Sacramento Valley of known decrease in groundwater elevations, known areas of subsidence (Faunt, ed., 2009; Exhibit 8.3), and apparently a GPS network with repeated elevation measurements (Exhibit 8.4), the Draft EIS/EIR doesn't provide any specific information on the "strategic" locations where groundwater substitution pumping done under the 10-year transfer project will require additional subsidence monitoring. The historic subsidence data along with the GPS grid elevation data, historic groundwater elevation change data and the future areas of drawdown from the 10 years of groundwater substitution pumping shown in Figures 3.3-26 to 3.3-31 should be sufficient information to develop the initial "strategic" locations for monitoring potential subsidence. The Draft EIS/EIR should be able to provide the specific thresholds of subsidence that will trigger the need for additional extensometer monitoring, continuous GPS monitoring, or extensive land-elevation benchmark surveys by a licensed surveyor as required by GW-1. The Draft EIS/EIR should also specify in mitigation measure GW-1, the frequency and methods of collecting and reporting subsidence measurements, and discuss how the non-participating landowners and the public can obtain this information in a timely manner. In addition, the Draft EIS/EIR should provide a discussion of the thresholds that will trigger implementation of the reimbursement mitigation measure required by GW-1 for repair or modifications to infrastructure damaged by non-reversible subsidence, and the procedures for seeking monetary recovery from subsidence damage (page 3.3-90). The revised Draft EIS/EIR should review the information provided by Galloway and others (2008), and the Pipeline Research Council International (2009) regarding land subsidence hazards.

An objective of the mitigation measure GW-1 is to mitigate adverse environmental effects from groundwater substitution transfer pumping (page 3.3-88). As part of the preliminary assessment of potential environmental impacts from subsidence due to groundwater substitution pumping, a review and determination of the critical structures that might be impacted is recommended. There are a number of critical structures in the Sacramento Valley that may be susceptible to settlement and lateral movement. These include natural gas pipelines, gas transfer and storage facilities, gas wells, railroads, bridges, water and sewer pipelines, water wells, canals, levees, other industrial facilities. Exhibits 8.5 to 8.11 provide several maps of gas pipeline, and gas and oil related facilities obtained from the web sites of the CA Energy Commission (CEC) and the CA Department of Conservation's Division of Oil, Gas and Geothermal Resources (DOGGR). In addition, composite maps (Exhibits 8.1a

59

60

61

to 8.1c) are provided that show the locations of the natural gas pipelines (Exhibit 8.6) with the DWR 2004 to 2014 change in groundwater elevation maps (DWR, 2014b). Additional maps of railroads, bridges, canals, levees, water and sewer pipelines and important industrial facilities should be sought and the location of those structures compared to the potential areas of subsidence from groundwater substitution transfer pumping. Specific “strategic” subsidence monitoring locations should be given in mitigation measure GW-I based on analysis of the susceptible infrastructure locations and the potential subsidence areas. The local, state and federal agencies that regulate these critical structures and pipelines as well as the facility owners should be contacted for information on the limitations on the amount of movement and subsidence the infrastructures can withstand. The limitations on movement and subsidence should be incorporated into any triggers or thresholds for additional monitoring and implementing mitigations needed to reduce subsidence impacts to less than significant and cause no injury.

I recommend that: (1) the Draft EIS/EIR be revised to provide information on initial “strategic” locations and types of subsidence monitoring that are necessary based on the existing conditions and the proposed groundwater substitution pumping areas; (2) the Draft EIS/EIR and mitigation measure GW-I be revised to provide specific thresholds of subsidence that will trigger the need for additional subsidence monitoring; (3) mitigation measure GW-I be revised to include the frequency and methods of collecting and reporting subsidence measurements; (4) the Draft EIS/EIR discuss how the non-participating landowners and the public can obtain subsidence information in a timely manner; (5) the Draft EIS/EIR and GW-I be revised to provide the thresholds that trigger implementation of the reimbursement mitigation measure required by GW-I for repair or modifications to infrastructure damaged by non-reversible subsidence along with the procedures for seeking monetary recovery from subsidence damage; and (6) the Draft EIS/EIR be revised to provide a map and inventory of critical structures in the Sacramento Valley that may be susceptible to settlement and lateral movement. These structures should include natural gas pipelines, gas transfer and storage facilities, gas wells, power plants, railroads, bridges, water and sewer pipelines, water wells, canals, levees, other industrial facilities. I further recommend that the Draft EIS/EIR solicit advice from local, state and federal agencies, as well as the infrastructure owners on the amount of subsidence that these critical structures and pipelines can withstand, and provide copies of their responses and incorporate their requirements in mitigation measure GW-I to ensure the stability and function of these facilities.

61

Geology and Seismicity

19. Environmental impacts from the project to geologic and soil resources are discussed in Section 3.4 of the Draft EIS/EIR. The Draft EIS/EIR assumes that because the projects don’t involve the construction or modification of infrastructure that could be adversely affected by seismic events, seismicity is not discussed in this section. The Geology and Soils section therefore focused on *chemical processes, properties, and potential erodibility of soils due to cropland idling transfers*. Impacts of subsidence are discussed in Section 3.3 of the Draft EIS/EIR and above in my comment no. 18.

62

The Draft EIS/EIR reasoning that because the projects don’t involve new construction or modification of existing structures that there are no potential seismic impacts from the activity undertaken during the transfers is incorrect. The project area has numerous

existing structures that could be affected by the groundwater substitution transfer pumping, specifically settlement induced by subsidence. Although the seismicity in the Sacramento Valley is lower than many areas of California, it's not insignificant. There is a potential for the groundwater substitution transfer projects to increase the impacts of seismic shaking because of subsidence causing additional stress on existing structures. The discussion in Section 3.3 on potential subsidence from groundwater substitution pumping was only qualitative because the SACFEM2013 simulations didn't calculate an estimate of subsidence from the transfer projects (page 3.3-61). The subsidence assessment also didn't acknowledge or consider the numerous natural gas pipelines or other critical facilities and structures that occur the Sacramento Valley. Exhibits 8.5 to 8.11 provide a series of maps that show some of the major natural gas pipelines, oil refineries, terminal storage, and power plants in the Sacramento Valley. In addition, there are a number of railroads, bridges, canals, and water and sewer pipelines within the transfer project area. As I discussed in my comment no. 18 on subsidence impacts, some of these existing structures and pipelines are sited within or traverse areas of known subsidence, existing areas of large groundwater drawdown, and areas within the proposed groundwater substitution transfer pumping. There are a number of technical documents on seismic impacts to pipelines (O'Rourke and Norberg, 1992; O'Rourke and Liu, 1999, 2012) as well as a proceeding from a recent ASCE conference on pipelines (Miami, Florida, August 2012).

62

The characteristics of future seismic shaking in California can be assessed using the following web resources provided by the California Geological Survey (CGS) in conjunction with the U.S. Geological Survey and other academic and professional organizations:

California Fault Activity Map web site:

<http://www.quake.ca.gov/gmaps/FAM/faultactivitymap.html>

Probabilistic Seismic Hazard Mapping web site:

<http://www.consrv.ca.gov/cgs/rghm/psha/pages/index.aspx>

Probabilistic Seismic Ground Motion Interpolator web site:

http://www.quake.ca.gov/gmaps/PSHA/psha_interpolator.html

Earthquake Shaking Potential for California Map web site:

http://www.conservation.ca.gov/cgs/information/publications/ms/Documents/MS48_revised.pdf

63

In addition to the potential impacts to existing infrastructure from seismic shaking, the occurrence of faults within the Sacramento Valley may influence the movement of groundwater. The USGS-CVHM groundwater model (Faunt, ed., 2009) incorporated a number of horizontal flow groundwater barriers (Figure C1-A, pages 160, 203, and 204; Exhibits 9.1, 9.2, 9.3a and 9.3b) that appear to align with faults shown in a series of screen plots from the interactive web site 2010 Fault Activity Map for California (CGS, 2010) (Exhibits 9.4a to 9.4d, 9.5 and 9.6). The SACFEM2013 model documentation didn't indicate that faults were considered as potential flow barriers and the resulting simulation maps in Figures 3.3-26 to 3.3-31 don't show any flow barriers.

I recommend that the Draft EIS/EIR be revised to: (1) assess the potential environmental impacts from seismic shaking on critical structures and pipelines in areas of potential subsidence caused by the groundwater substitution transfer pumping; (2) provide maps that identify and locate existing pipelines and critical structures such as storage facilities, railroads and bridges within the areas

affected by groundwater substitution pumping; (3) solicit and provide results of the advice from local, state and federal agencies, as well as the infrastructure owners, on the amount of subsidence that these critical structures and pipelines can withstand under in both static and seismic conditions; (4) provide a mitigation measure(s) that addresses the requirements for monitoring the subsidence in the area of these critical structures and pipelines; and (5) provide specific monitoring and reporting requirements for potential seismic impacts to critical structures that includes establishing any additional structures for monitoring and taking subsidence measurements, and conducting additional periodic surveys of ground elevation and displacement. I recommend the Draft EIS/EIR be revised to provide the thresholds that trigger implementation of the reimbursement mitigation measure required by GW-1 for repair or modifications to infrastructure that may be damaged by seismic movement in areas that have exceeded the thresholds for non-reversible subsidence, and provide procedures for seeking monetary recovery from subsidence damage. I also recommend the Draft EIS/EIR be revised to discuss the importance and impacts of the horizontal flow barriers and/or faults within the Sacramento Valley on the results of the drawdown and stream depletion simulations of SACFEM2013.

63

II. Additional Technical Information Relevant to the Assessment of Potential Environmental Impacts from the 10-Year Groundwater Substitution Transfers.

Historic Changes in Groundwater Storage

20. The Draft EIS/EIR provides SACFEM2013 simulations of groundwater substitution transfer pumping effects for WY 1970 to WY 2003. The discussion of the simulation didn't provide specifics on how the model simulated the current conditions of the Sacramento Valley groundwater system or the potential impacts from the 10-year groundwater substitution transfer project based on current conditions. A DWR groundwater contour map, Figure 3.3-4, shows the elevations in the spring of 2013 for wells screened at depths greater than 100 ft. bgs. and less than 400 ft. bgs. Figures 3.3-8 and 3.3-9 provide the locations and simulation hydrographs for selected monitoring wells in the Sacramento Valley. Appendix E provides additional monitoring well simulation hydrographs for selected wells at locations shown on Figures 3.3-26 to 3.3-31. As discussed above in comments no. 7, these hydrographs appear to show only simulated groundwater elevations. Actual measured groundwater elevations are needed to evaluate the accuracy of the simulations. The Draft EIS/EIR briefly discusses on page 3.3-12 the groundwater production, levels and storage for the Redding Basin, and on pages 3.3-21 to 3.3-27 there is a similar discussion for the Sacramento Valley. Faunt (ed., 2009) is cited for the conditions of the Sacramento Valley groundwater budget and Figure 3.3-10, taken from Faunt (ed., 2009; Figure B9; Exhibit 10.2a), shows the historic change in groundwater storage in the Central Valley as determined by the CVHM model simulations. Based in part on the information in Faunt (ed., 2009), the Draft EIS/EIR concludes that the Sacramento Valley basin's groundwater storage has been relatively constant over the long term, decreasing during dry years and increasing during wetter periods. However, the Draft EIR/EIS's discussion of the status of groundwater in the Sacramento Valley doesn't utilize all of the information on groundwater storage or water balance available in Faunt (ed., 2009), more recent simulation studies by Brush and others (2013a and 2013b), or the summary of groundwater conditions in recent reports by the Northern California Water Association (NCWA) (2014a and 2014b).

64

Faunt (ed., 2009) provides in Table B3 (Exhibit 10.1) selected average annual hydrologic budget values for WYs 1962-2003. In addition, Figures B10-A and B10-B of Faunt (ed., 2009) show bar graphs for the average annual groundwater budget for the Sacramento Valley and the Delta and Eastside Streams (Exhibits 10.2b and 10.2c). Table B3 gives the water balances for subregions in the Sacramento Valley (1 to 7) and the Eastside Streams (8). Table B3 gives values for the *net storage from specific yield and compressibility of water*; positive values indicate an increase in storage, while a negative value is a decrease. For Sacramento Valley, the sum of the annual average from 1962 to 2003 in net storage is given as -99,000 AFY and for the Eastside streams -26,000 AFY. Unfortunately, the components in Table B3 don't seem to be a complete groundwater water budget, so following the calculations of the average annual net change in groundwater storage isn't obvious. Figures 10A and 10B (Exhibits 10.2a and 10.2b), however, do provide bar graphs of the groundwater water budgets with values for the entire Sacramento Valley and the Delta and Eastside Streams. If it's assumed that groundwater pumping shown as a negative value in Figures 10A and 10B represents an outflow from groundwater storage, then other negative values would also be considered outflows. Positive values are therefore assumed to be inflows to groundwater storage.

65

For the entire Sacramento Valley (subregions 1 to 7), Faunt (ed., 2009) shows the net change in annual groundwater storage as the sum of the negative outflows and positive inflow in Figure 10A at a negative 650,000 AFY (-0.65 million AFY) ($2.88 - [0.29+0.03+1.66+1.37+0.18] = 2.88 - 3.53 = -0.65$). The values in Figure 10B can be summed in a similar manner and yield a net change in storage of a positive 90,000 AFY for the Delta and Eastside Streams. Unfortunately, the bar graph in Figure 10B for the Eastside Streams (subregion 8) doesn't have numerical values. A visual comparison of the inflow and outflow bars suggests that for subregion 8 the outflows, mostly pumping, are at or slightly greater than the inflows.

The groundwater budget information by Faunt (ed., 2009) can be compared with two other more recent sources of Sacramento Valley information contained in four documents, Brush and others (2013a and 2013b) and NCWA (2014a and 2014b). Brush and others report on the recent version of the C2VSim groundwater model (version R374) and provide simulation results. The NCWA reports also used the C2VSim (R374) model, but provided additional analysis and results of the historic land development, water use and water balances in Sacramento Valley. Some of the information developed by Brush and others (2013a and 2013b), and Faunt (ed., 2009) on the condition of the Sacramento Valley groundwater system was previously discussed in my comments on the SACFEM2013 model simulations, nos. 8 to 14.

66

My comment no. 14 on groundwater flow between subregions is also relevant to this discussion of the historic changes in groundwater storage. Accounting for the transfer of groundwater between regions is critical for understanding the impacts of pumping in one region or area on the adjacent regions. The sources of water backfilling a groundwater depression don't all have to come from surface waters, ie., stream depletion, precipitation, deep percolation, and artificial recharge. Some of that "recharge" can come from adjacent aquifers by horizontal and vertical flow. When pumping creates a depression in the water table or piezometric surface, the depression steepens the gradient thereby increasing the rate of flow towards it; the depression can also change the direction of groundwater flow. Often the "recharge" to a pumping depression comes from adjacent groundwater storage that lies outside the zone of influence of the pumping. When the rates and volumes of recharge from surface waters are insufficient to rapidly backfill a pumping depression, the impact on groundwater storage and elevations in adjacent regions increases.

67

Brush and others (2013a) provide a breakdown of water budget by subregion, Tables 10 to 13 (Exhibits 6.3a to 6.3d), but only for the selected three decades (1922-1929, 1960-1969, and 2000-2009), and for the total modeled period from 1922 to 2009. They do provide values for the change in groundwater storage for all 21 of the Central Valley subregions and 5 hydrologic regions. Of particular importance to the discussion of the current condition of the groundwater basin are the results of the C2VSim simulations of the annual average change in groundwater storage for each of the three decades and from 1922 to 2009, Tables 10 to 13 (Exhibits 6.3a to 6.3d). For the Sacramento Valley (subregions 1 to 7), Table 10 lists the 1922-2009 change in storage as -165,417 AFY (I'm assuming the units of the table are acre-feet), and for the Eastern Streams (subregion 8) -135,304 AFY. For the most recent decade, 2000-2009, the average annual change in groundwater storage has increased in both the Sacramento Valley and the Eastern Streams to -303,425 AFY and -140,715 AFY, respectively (Table 13). Although the tables in Brush and others don't list the groundwater flow between subbasins, Figures 81A to 81C (2013a) and Figure 39 (2013b) (Exhibits 6.1a to 6.1c and 6.2) provide this information for the selected decades and for the total simulation period. As discussed above in my comment no. 14, the change in interbasin groundwater flow can be significant particularly when recharge in a region is deficient. The Draft EIS/EIR should specifically discuss and account for any changes in the rate and direction of interbasin groundwater flow. Interbasin groundwater flow may become a hidden long-term impact that increases the time needed for recovery of groundwater levels from groundwater substitution transfer pumping, and can extend the impact from groundwater substitution transfer pumping to areas outside of the groundwater substitution transfer seller's boundary.

68

Two recent reports on the condition of groundwater in the Sacramento Valley are provided by the Northern California Water Association (NCWA, 2014a and 2014b). Tables 3-6, 3-7, and 3-8 in the NCWA technical supplement report (2014b; Exhibits 10.5a to 10.5c) provide water balance information for the Sacramento Valley for the same three decades as Brush and others (2013a). The NCWA tables separate the water balance elements into three types, land uses (Table 3-6), streams and rivers (Table 3-7), and groundwater (Table 3-8). The values of the change in groundwater storage given in Table 3-8 are similar to those given by Brush and others (2013a). The NCWA technical supplement report (2014b) also provides additional information on the 1922 to 2009 water balance through the use of graphs and bar charts. Figures 3-22 and 3-24 (Exhibits 10.6c and 10.6d) provide graphs of simulated estimates of annual groundwater pumping in the Sacramento Valley and the annual stream accretion. Positive stream accretion occurs when groundwater discharges to surface water, negative when groundwater is recharged. Other graphs include simulated deep percolation, Figures 3-26 and 3-27 (Exhibits 10.6e and 10.6f), annual diversions, Figures 3-19 and 3-20 (Exhibits 10.6a and 10.6b), and relative percentages of surface water to groundwater supplies, Figure 3-29 (10.6g).

69

The NCWA technical supplement report (2014b) notes in Sections 3.8 and 3.8.4 that negative changes in groundwater storage

... suggest that the groundwater basin is under stress and experiencing overdraft in some locations. Review of the Sacramento Valley water balance, as characterized based on C2VSim R374 and summarized in Tables 3-6 through 3-8 reveals substantial changes in water balance parameters over time that affect overall groundwater conditions. ... Over time, it appears that losses from surface streams have increased as a result of declining groundwater levels. The declining levels result from increased demand for groundwater as a source of supply without corresponding increases in groundwater recharge. (page 41)

A contributing factor to the decrease in accretions to rivers and streams over the last 90 years is that deep percolation of surface water supplies (and other forms of recharge) has not increased in a manner that offsets increased groundwater pumping. (page 48)

The simulated groundwater pumping graph in NCWA Figure 3-22 and stream accretion graph in NCWA Figure 3-24 were combined into one graph by scaling and adjusting their axes (Exhibits 10.7). The vertical scales of these two graphs were adjusted so that a zero value of stream accretion aligned with 1.5 million acre-feet (MAF) of annual groundwater pumping. This alignment was done to reflect the fact that in the early 1920s, groundwater pumping was approximately 0.5 MAF per year (MAFY) while stream accretion was approximately 1.0 MAFY. As shown in the combined graph, stream accretion generally decreases at approximately the same rate as groundwater pumping increases. Thus, at a point of no appreciable groundwater pumping, pre-1920s, the total long-term average annual stream accretion was likely 1.5 MAF, based on the C2VSim simulations.

69

Drawn on top of the stream depletion and groundwater pumping graphs are several visually fit, straight trend lines. These lines, which run from 1940 to the mid-1970s and the late 1980s to mid-1990s, are mirror images reflected around the horizontal 0 accretion axis. Information provided at the bottom of the composite graph was taken from NCWA Tables 3-7 and 3-8 (Exhibits 10.5b and 10.5c). The slope of the trend line from 1940 to the mid-1970s is approximately (+-)27,000 AFY, and (+-)85,000 AFY in the late 1980s to the mid-1990s; a 3-fold increase in slope. After the mid-1990s the slope of groundwater pumping flattens to be similar to that of the 1940s–mid-1970s, while the stream depletion line became almost flat, ie., no change in rate of accretion. The reason for the stream depletion rate being flat is unknown, but there are several factors that could contribute to a fixed rate of stream accretion.

70

First, after depleting 1.5 MAFY from the Sacramento Valley streams, the surface waters may not be able to provide much more, at least no increase to match the pumping. Second, this may also be a consequence of the model design because the number of streams simulated was limited. Third, the model's grid may not extend out far enough to encompass all of the streams that contribute to groundwater recharge. More information on the areas of where streams gain and lose in the Sacramento Valley is needed to determine if there are any sections of stream, gaining or losing, that might still have the ability to interact at a variable rate in the future, ie., during and after the 10-year groundwater substitution transfer project.

A third graph is drawn on the composite accretion-pumping graph in Exhibit 10.7 that shows the C2VSim simulated cumulative change in groundwater storage for the Sacramento Valley from 1922 to 2009. This graph was taken from Figure 35 of Brush and others, 2013b (Exhibit 10.4). A straight trend line with a negative slope of approximately -163,417 AFY is drawn on top of the third graph, which is the value for average annual change in storage from 1922 to 2009 given in Table 10 of Brush and others (2013a; Exhibit 6.3a) for the seven subregions of the Sacramento Valley. The selected graph of the cumulative change in groundwater storage is one of three available.

71

The graph of cumulative change in groundwater storage for the Sacramento Valley in Figure 35 differs from the graph in Figure 83 in Brush and others (2013a; Exhibit 10.3) and in Figure B9 of Faut (ed., 2009; Exhibit 10.2a). Both of Figure 83 and Figure B9 show a gain in groundwater storage with their Sacramento Valley graphs lying generally above the horizontal line of zero change in storage. The cumulative change in groundwater storage graph from Figure 35 (Exhibit 10.4) was selected because:

- its slope is a close match for the average annual change in storage from 1922 to 2009 of -163,417 AFY given in Table 10,
- the values for change in groundwater storage in the three selected decades are all negative (Table 3-8, NCWA, 2014b), which the other two graphs don't clearly indicate,
- the calculation of average annual change in groundwater storage from 1962 to 2003 shown in Table B3 and Figures B10-A and B10-B of Faunt (ed., 2009) are negative, which conflicts with Figures B9 and 83, and
- change in DWR groundwater elevation maps from spring 2004 to spring 2014 (Exhibit 3.1, 3.2 and 3.3) suggest that there are significant regions of the Sacramento Valley that have lost groundwater storage, which suggests that the current condition is one of a loss in storage rather than a gain.

71

Additional review and analysis of the changes in groundwater storage in the Sacramento Valley is needed. Any additional review of changes in groundwater storage in the Sacramento Valley should consider the recent changes in groundwater elevations such as those shown in DWR (2014b) for WYs 2004 to 2014, and Figures 2-4 and 2-5 of NCWA, 2014b (Exhibit 10.8 and 10.9), as well as other studies such as the support documents for the regional IRWMPs.

I recommend the Draft EIS/EIR be revised to provide a more comprehensive assessment of the historic change in groundwater storage in the Sacramento Valley groundwater basin, and other seller sources areas within the proposed 10-year groundwater substitution transfer project. I also recommend that the Draft EIS/EIR be revised to include an assessment of the impacts of groundwater flow among subregions due to the proposed 10-year groundwater substitution transfer project.

The Concept of the Stream Depletion Factor, SDF

21. The Draft EIS/EIR proposes that a stream depletion factor, BoR-SDF, be applied to groundwater substitution transfers as mitigation for flow losses due to groundwater pumping. The Draft EIS/EIR implies that the BoR-SDF will be a fixed percentage of the transferred groundwater substitution water. The main text of the Draft EIS/EIR doesn't clearly specify the BoR-SDF percentage, but appended documents state that the default is 12%, *unless available monitoring data analyzed by Project Agencies supports the need for the development of a transfer proposal site-specific SDF* (page 33 in the DTIPWTP). Elsewhere in the Draft EIS/EIR, the average annual surface water-groundwater interaction losses are estimated at approximately 15,800 AF and in multiple dry years losses of 71,200 AFY are anticipated (page 3.1-18). The Draft EIS/EIR proposes mitigation measure WS-1, which utilizes the BoR-SDF with the transfers to account for the losses from stream depletions, and thereby reduces the water supply impacts to less than significant (page 3.1-18). As I discussed above in my comment no. 9, the maximum annual groundwater substitution pumping is 290,495 AF as calculated from Table 2-5. The estimated annual average surface water-groundwater interaction loss of 15,800 AF is 5.4 % of the maximum allowable annual groundwater substitution transfer, while a loss of 71,200 AF is 24.5%.

72

The use of a fixed percentage of transfer water to mitigate increased stream flow losses from the groundwater substitution pumping may not result in the reduction of stream flow impacts to less than significant. I've discussed above in my comment no. 15 several of the issues about the design of mitigation measure WS-1. The following are additional comments on WS-1 specific to the fixed percentage BoR-SDF and how it differs from the concept of stream depletion commonly used in scientific literature.

Jenkins (1968a and b; Barlow and Leake, 2012) defined the “stream depletion factor” (herein called the Jenkins-SDF) as the product of the square of the distance between a well and a surface water body (a^2) multiplied by the storage coefficient (S or S_y) divided by the transmissivity (T) (Jenkins-SDF = distance² × storage coefficient/transmissivity = $a^2 \times S/T$) (see Table I and page 14 in Barlow and Leake, 2012). The units of the Jenkins-SDF are in time, i.e., days, years, etc. The Jenkins-SDF also occurs in Theis’ well function, $W(u)$ (see pages 136 and 150 in Domenico and Schwartz, 1990). Domenico and Schwartz (1990) showed that the Jenkins-SDF can be expressed as a dimensionless Fourier number, which occurs in all unsteady groundwater flow problems. The Jenkins-SDF has several other important characteristics that are not part of the BoR-SDF, which likely influence the actual rate and volume of surface water lost due to groundwater substitution transfer pumping.

73

1. The value of stream depletion varies with the duration of pumping and unlike the BoR-SDF isn’t a fixed value. For an ideal aquifer (homogeneous, isotropic and infinite), two ideal curves normalized to the Jenkins-SDF value can be created that show stream depletion as a percentage of the total pumping rate or total pumped volume against the normalized logarithm of pumping time (see Figure I from Miller and Durnford, 2005; Exhibit 11.1). In Figure I, equation no. 1 shows the instantaneous rate of stream depletion as a percentage of the maximum pumping rate versus the logarithm of normalized time, and equation no. 2 shows the volume of depletion as a percentage of the total volume pumped versus the logarithm of normalized time. Jenkins somewhat arbitrarily defined his SDF as the pumping duration equal to the calculated stream depletion factor ($a^2 \times S/T$). Jenkins noted that for the ideal aquifer at the time of the SDF, the cumulative volume of water depleted from the stream equals 28% of the total volume pumped (Jenkins, 1968a; Wallace and Durnford, 2005 and 2007). As shown in Figure I in Exhibit 11.1, when the actual pumping duration is normalized to the Jenkins-SDF, the ideal volume curve always goes through 28% when the pumping time equals the Jenkins-SDF (time/SDF = 1; Jenkins, 1968a).
2. An important factor in the Jenkins-SDF is that stream depletion varies with the square of the distance between the well and the stream, whereas, the depletion rate varies only linearly with changes in S or T . The ratio of T/S is also called the hydraulic diffusivity, D , which has units of length²/time (see Table I and Box A in Barlow and Leake, 2012). The rate that hydraulic stress propagates through an aquifer is a function of the diffusivity. Greater values of D result in more rapid propagation of hydraulic stresses. Barlow and Leake (2012) note that the ratio T/S (or T/S_y) controls the timing of stream depletion and not each value individually. Streamflow depletion can occur more rapidly in confined aquifers than in unconfined aquifers because S is much smaller than S_y , resulting in a larger D value.
3. For a given duration of pumping, the percentage of instantaneous depletion is greater than the percentage of volume depleted. For the ideal aquifer at a pumping duration equal to the Jenkins-SDF value, the instantaneous depletion is 48% of the maximum pumping rate, while the cumulative volume of depletion is 28% of the total pumped volume (Figure I, Exhibit 11.1). For a non-ideal aquifer where numerical simulations are needed to estimate stream depletion, eg., the SACFEM2013 simulations, the time when the cumulative volume of stream depletion is at 28% of the total volume pumped can be used as an “effective” Jenkins-SDF to allow for evaluation and comparison of potential impacts from pumping.
4. Stream depletion continues to occur after pumping ceases. Jenkins (1968a, b) referred to this as residual depletion. Depending on the duration of pumping and the value of the Jenkins-SDF, stream depletion can be greater after pumping ceases (see

74

75

76

77

pages 42 to 45 in Barlow and Leake, 2012). Barlow and Leake (2012 on page 43) give the following five key points regarding stream depletion after cessation of pumping:

- a. *Maximum depletion can occur after pumping stops, particularly for aquifers with low diffusivity or for large distances between pumping locations and the stream.*
 - b. *Over the time interval from when pumping starts until the water table recovers to original pre-pumping levels, the volume of depletion will equal the volume pumped.*
 - c. *Higher aquifer diffusivity and smaller distances between the pumping location and the stream increase the maximum rate of depletion that occurs through time, but decrease the time interval until water levels are fully recovered after pumping stops.*
 - d. *Lower aquifer diffusivity and larger distances between the pumping location and the stream decrease the maximum rate of depletion that occurs through time, but increase the time interval until water levels are fully recovered after pumping stops.*
 - e. *Low-permeability streambed sediments, such as those illustrated in figure 11, can extend the period of time during which depletion occurs after pumping stops.*
 - f. *In many cases, the time from cessation of pumping until full recovery can be longer than the time that the well was pumped.*
5. As noted above in key point no. 4b, the volume of stream depletion will eventually equal the total pumped volume. The time required for full aquifer recovery from pumping depends on the value of the Jenkins-SDF, availability of water to capture, the rate and duration of recharge above what normally occurs, and other factors like the streambed sediment permeability and aquifer layering. Figure 1 in Exhibit 11.1 also shows that for an ideal aquifer the time needed to reach 95% depletion is approximately 127 times the Jenkins-SDF value. This is consistent with the estimates made by Wallace and others (1990) in Table 3 (Exhibit 11.2) on the time it takes to reach 95% depletion, which they consider a point where a new dynamic equilibrium is established. Although the 127-times-SDF multiplier assumes continuous pumping, the fact is the time for full recovery by residual depletion without pumping shouldn't be any sooner than it takes to obtain 95% stream depletion with pumping. In other words, rate and volume of loss from a stream can't be any higher without pumping than with pumping, all other parameters being equal. This means that without some additional source of recharge above what normally occurs, including natural wet and dry cycles, the total time required to achieve full recovery from the 10 years of groundwater substitution transfer pumping will be much longer than the 5 years cited in the Draft EIS/EIR (pages 3.3-80). For additional discussion of the stream depletion under natural variations in recharge and discharge see Maddock and Vionnet (1998).

Another factor that isn't clearly acknowledged in the Draft EIS/EIR is the difference between the instantaneous depletion rate and cumulative volumetric depletion rate. The Draft EIS/EIR appears to focus on cumulative volumetric depletion in mitigation measure WS-1. However, the instantaneous stream depletion rate is probably more important when evaluating impacts to fisheries and stream habitat. The instantaneous rate of flow, instantaneous depth of flow and the corresponding instantaneous wetted perimeter of flow at any point in a stream are the best measures of habitat value to the fish and other water dependent species. The cumulative volume of stream depletion relative to the total pumped volume, on the other hand, can't be easily translated stream to instantaneous flow, water depth or wetted perimeter at a point in a stream because discharges having different hydrographs can result in the same total volume of flow. For example, if I estimate that the stream depletion during a 3- to 6-month period of groundwater substitution pumping will be a maximum of 1 cubic-foot-per-second, I can evaluate the significance of this change to the stream's habitat value using the stream's historic hydrograph and fluvial geomorphology. However, if I estimate that over the same period of pumping the stream will lose, at the end

77

78

79

of pumping, a total 12 percent of the total volume pumped, I can't determine what changes will occur in the habitat function of the stream at a specific time and place. Perhaps, if I assume that the cumulative volume of stream depletion increases linearly with time, going from zero at time zero, to 12% at the end of pumping, then I could also assume that the instantaneous rate of stream depletion would also change linearly from 0% at the start to 24% of the pumping rate at the end of pumping. Remember that in this case the area under the instantaneous depletion curve is triangular, and therefore the maximum instantaneous depletion rate would be twice the total cumulative depletion rate. In reality, the ratio of instantaneous to volumetric depletion for the ideal Jenkins-SDF curves vary with pumping duration; the ratio is approximately 1.7:1 for time/SDF = 1 (Figure 1, Exhibit 11.1). Figure 1 also shows for the ideal curve that when the instantaneous depletion (eq. 1) is 24%, the volumetric depletion is 10% (eq. 2), a ratio of 2.4:1, and when eq. 1 is at 83%, eq. 2 is at 70%, a ratio of 1.19:1.

79

Mitigation measure WS-1 appears to be based on the cumulative volume of water pumped for each period of groundwater substitution transfers, not the instantaneous rate of stream depletion caused by the pumping. Mitigation measure WS-1 uses of a fixed value for compensating stream losses, which is inconsistent with the hydraulics of stream depletion. Because stream depletion actually increases with pumping time, mitigation measure WS-1 needs to specify the maximum duration of pumping allowed, ensuring that the depletion rate stays below the WS-1 value, ie., 12%. This maximum duration of pumping should be established based on impacts to stream habitat from instantaneous changes in stream flow, not the cumulative change in volume. The maximum duration of allowable pumping would change with the distance between the well and stream and with the diffusivity around each well because these control the rate of stream depletion. The well acceptance criteria in Table B-1 of Appendix B in the DTIPWTP suggests that some calculation has been made to establish the specified setback distances, but no methodology or calculation is given in the Draft EIS/EIR. The Draft EIS/EIR should document how the maximum allowable stream depletion rate, instantaneous and volumetric, and the associated maximum duration of pumping will be calculated for each well in the groundwater substitution transfer project.

80

Although the Draft EIS/EIR doesn't fully evaluate the potential stream depletion that may occur with the proposed 10-year groundwater substitution transfer project, another report prepared by CH2MHill (2010) and submitted to DWR provides additional analysis on the simulated impacts from the 2009 groundwater substitution transfers. The simulations of the 2009 transfer impacts were done using the SACFEM model, presumably an earlier version of the SACFEM2013 model. Figures 4, 5 and 6 in the CH2MHill 2010 report provide simulation graphs of stream depletion for three groundwater substitution transfer periods, 1976, 1987 and 1994 (Exhibits 11.3a to 11.3c). Graphs (a) to (c) in each figure appear somewhat like Figures B-5 and B-6 in Appendix B of the Draft EIS/EIR in that they show a depletion peak shortly after pumping starts, with a gradual decay following the cessation of pumping. Graphs (d) of Figures 4, 5 and 6 are not provided in the Draft EIS/EIR, but provide important additional information. These (d) graphs show the cumulative depletion for each of the three scenarios and are essentially the volumetric depletion curve of eq. 2 in Miller and Durnford's Figure 1 (Exhibit 11.1). These cumulative volume depletion curves are important because they show the time needed to fully recover from the three groundwater substitution transfer pumping events. For example, Figure 4(d) shows that recovery from the pumping event in 1976 is only approximately 60% after 25 years; much longer than the 5 years for 55% to 75% recovery stated in the Draft EIS/EIR (pages 3.3-70). For comparison, Figure 4(d) of CH2Mhill (2010) is plotted on Miller and Durnford's Figure 1 in Exhibit 11.1 by normalizing the values plotted in 4(d) by an effective Jenkins-SDF value of 2.4 years.

81

Notice that for the simulated Figure 4(d) Jenkins-SDF curve, depletion initially occurs sooner than with an ideal aquifer, but then depletion slows. At 127 times the SDF, approximately 300 years, the depletion is at approximately 80%.

A point can be identified on each graph (d) where the volume of stream depletion is equal to 28%, the Jenkins-SDF point, and the time since pumping started measured. For example, in Figure 4(d) approximately at approximately 2.4 years after the beginning of pumping the volume of depletion reaches 28%. For Figure 5(d) the time to 28% is similar, estimated at 2.3 years. The time interval to 28% volumetric depletion in Figure 6(d) is significantly greater at an estimated 7.5 years. The results presented in both Figures 4 and 5 are from simulation of stream depletion during dry or critically dry years followed by normal or dry years, while the simulation scenario of Figure 6 is for a critical year followed by wet years. All of the cumulative (d) graphs are filtered for the Delta conditions. This may be the reason it takes longer for stream depletion to reach 28% during a wet period than dry period when one might expect the opposite because of the increased stream flow would provides more water for recharge.

The point of this discussion is that the simulated stream depletions from the SACFEM2013 modeling can also be presented as cumulative depletion response curves that are normalized by the effective Jenkin-SDF time. The stream depletion can then be estimated for any rate or duration of pumping at an individual well when the stream depletion response curves given as percentages of both the maximum pumping rate and total volume pumped are normalized to the effective Jenkins-SDF (without the Delta conditions filter). Losses for different distances between the well and surface water feature can be roughly estimated without the need to run another simulation by adjusting the Jenkins-SDF curves by the ratio of the square of the different distances. Cumulative depletion for different pumping rates during and following the 10-year groundwater substitution transfer project can be estimated by the principle of superposition (Wallace and other, 1990; Barlow and Leake, 2012). As I discussed in my comment no. 15b, additional discussion is needed in the Draft EIS/EIR on how the amount of stream depletion for WS-I is calculated. This discussion should include normalized stream depletion response curves for each groundwater substitution transfer well so that impacts from pumping can be estimated for different pumping durations and rates.

Barlow and Leake (2012) provide an extensive discussion of the factors controlling stream depletion including several misconceptions (pages 39 to 45). Review of their discussion of stream depletion misconceptions is recommended as part of any revision of the Draft EIS/EIR. Barlow and Leake identified the following misconceptions regarding stream depletion (page 39):

- *Misconception 1. Total development of groundwater resources from an aquifer system is “safe” or “sustainable” at rates up to the average rate of recharge.*
- *Misconception 2. Depletion is dependent on the rate and direction of water movement in the aquifer.*
- *Misconception 3. Depletion stops when pumping ceases.*
- *Misconception 4. Pumping groundwater exclusively below a confining layer will eliminate the possibility of depletion of surface water connected to the overlying groundwater system.*

I recommend that the Draft EIS/EIR be revised to document stream depletion response curves for each groundwater substitution transfer well. These response curves should be normalized to the effective Jenkins-SDF value, given as a percentage of the pumping rate and total pumped volume, along with the

81

82

83

distance between the well and the modeled surface water feature. Multiple stream depletion response curves should be provided, if necessary. I recommend that the Draft EIS/EIR be revised to review how the BoR-SDR value accounts for the variability in rate and volume of stream depletion. I recommend that the Draft EIS/EIR be revised to document how the maximum allowable instantaneous and volumetric stream depletion rates, and the associated maximum duration of pumping will be calculated for each well in the groundwater substitution transfer project to ensure that the BoR-SDR provides adequate flow mitigation. I recommend that the Draft EIS/EIR be revised to discuss how WS-I addresses the common stream depletion misconceptions noted by Barlow and Leake (2012).

83

Measurement of Stream Seepage in Real Time

22. Barlow and Leake (2012) state that methods for determining the effects of pumping on stream flow follow two general approaches: (1) collection and analysis of field data, and (2) analytical and numerical modeling (page 50). The Draft EIS/EIR states in the OTIPWTP that stream depletion can't be measured in real time (page 33) and instead relies on simulations of groundwater pumping to determine impacts to surface waters. As discussed in **my comment no. 15b**, the Draft EIS/EIR also states that monitoring of surface water-groundwater interaction is part of mitigation measures WS-I and GW-I. The statement that stream depletion measurements, ie., stream seepage rates, surface water depths, and surface flows, can't be done in "real time" conflicts with scientific literature. Measurements of stream flow and water depth are fundamental to stream surveys. Although measurement of the seepage rate from or into a stream is done less often and is generally more difficult than other direct surface water measurements, procedures for making these measurements are well documented (Barlow and Leake, 2012; Rosenberry and LaBaugh, 2008; Zamora, 2008; Stonestrom and Constantz, ed., 2003; Constantz, 2008; Kalbus and others, 2006). Linking field measurements to changes in stream flow and seepage to adjacent groundwater pumping is made more difficult because of the lag between the start of pumping and stream response, damping of the pumping response with increases in distance between the well and measured surface water body, and the variation in seepage rate with the increases in pumping time or pumping cycles. Measurements of surface water and groundwater flow are also difficult because of inherent measurement errors that are sometimes greater than the change in flow being sought. Barlow and Leake (2012) discuss the measurement of stream depletion and conclude that:

84

Two general approaches are used to monitor streamflow depletion: (1) short-term field tests lasting several hours to several months to determine local-scale effects of pumping from a specific well or well field on streams that are in relative close proximity to the location of withdrawal and (2) statistical analyses of hydrologic and climatic data collected over a period of many years to test correlations between long-term changes in streamflow conditions with basinwide development of groundwater resources. Direct measurement of streamflow depletion is made difficult by the limitations of streamflow-measurement techniques to accurately detect a pumping-induced change in streamflow, the ability to differentiate a pumping-induced change in streamflow from other stresses that cause streamflow fluctuations, and by the diffusive effects of a groundwater system that delay the arrival and reduce the peak effect of a particular pumping stress. (Page 77)

The Draft EIS/EIR provides the following statements in the DTIPWTP regarding groundwater substitution transfers, which are therefore part of mitigation measure GW-I:

- ... must account for ... the extent to which transfer-related groundwater pumping decreases

streamflow (resulting from surface water-groundwater interaction), and the timing of those decreases in available surface water supply. (page 25);

- Project Agencies are developing tools to more accurately evaluate the impacts of groundwater substitution transfers on streamflow. These tools may be implemented in the near future and may include a site-specific analysis that could be applied to each transfer proposal. (page 33);
- Water transfer proponents transferring water via groundwater substitution transfers must establish a monitoring program capable of identifying any adverse transfer related effects before they become significant. (page 34);

The objectives of the DTIPWTP groundwater substitution transfer-monitoring program include:

- Determine the extent of surface water-groundwater interaction in the areas where groundwater is pumped for the transfer;
- Determine the direct effects of transfer pumping on the groundwater basin, observable until March of the year following the transfer;
- Assess the magnitude and potential significance of any effects on other legal users of water, instream beneficial uses, the environment, and the economy. (page 34)

All of these statements and monitoring objectives imply that measurement of impacts to surface water from groundwater substitution transfer pumping is possible. While measurement of stream depletion is complex and problematic, it is possible. The conflicting statements in the Draft EIS/EIR that “real time” measurements can’t be done while apparently including a requirement for field monitoring of the effects of stream depletion in mitigation measures WS-I and GW-I need further explanation.

I recommend that the Draft EIS/EIR be revised to evaluate and discuss the methods, techniques and procedures available for monitoring and measuring the rate, volume and impacts of stream depletion due to groundwater substitution transfer pumping. The revised Draft EIS/EIR should provide specific mitigation measures, procedures and methods for monitoring groundwater substitution transfer pumping impacts on surface water features, including the frequency of monitoring and reporting.

Other Available Data to Consider in the Establishing Baseline Conditions

23. The Draft EIS/EIR for the 10-year long-term water transfer project should provide a review of the existing technical documents that describe historic environmental, surface water and groundwater conditions in the Sacramento Valley. The information in these technical documents is critical for establish an accurate and complete environmental baseline and for evaluating the potential impacts from future water transfers. Exhibit 12.1 provides an annotated bibliography provided by researchers with AquAlliance (Nora and Jim) of some of the available technical reports on groundwater resources in the Sacramento Valley. In addition to creating a complete bibliography of relevant technical reports, the Draft EIS/EIR should provide an index map showing the areas or locations covered by each report should be developed. For an example of an index map, see the 1:250000 scale regional geologic map sheets produced by the California Geological Survey.

Other information is likely available from local government agencies that would document the current condition of the groundwater basin both quantity and quality. For example, Exhibit 12.2 has a list provide by B. Smith, a researcher with AquAlliance, of recently well permits issued since January 1, 2009 for wells that have gone dry in Shasta County. A GIS should be used to plot the locations of the wells that have gone dry. The locations of these dry wells should then be compared to the current groundwater levels, past groundwater

84

85

86

substitution transfer pumping areas, and the proposed 10-year long-term project pumping areas. This type of spatial analysis would help to establish an accurate baseline on groundwater elevations and impacts on existing wells, and provide the foundation for assessing the potential impacts from the 10-year long-term groundwater substitution transfer pumping. Other relevant information on baseline conditions in the 10-year Transfer Project area can be found in the Integrated Regional Water Management Plans for the Northern Sacramento Valley Basin, the American River Basin, Yuba County, and Yolo County, see my comment no. 6.

I recommend the Draft EIS/EIR be revised to provide an annotated bibliography and index map(s) of all documents that are relevant to proposed 10-year long-term water transfer project and describe or provide data on the historic and environmental, surface water and groundwater baseline conditions in the Sacramento Valley. I also recommend the Draft EIS/EIR be revised to provide information from local and regional agencies on the conditions of wells within their jurisdictions covering at least the last 10 years. This local information should include, if available, replacement well permits issued for dry wells, complaints or treatment systems installed because of poor water quality, and damage to infrastructure from subsidence or settlement. I recommend this information be mapped and compared to areas of past groundwater substitution transfer pumping, areas of known groundwater level depression, and the pumping area for the proposed 10-year project.

86

Reference Cited

- ASCE (American Society of Civil Engineers), 2012, Pipelines 2012: Innovations in Design, Construction, Operations, and Maintenance, Doing More with Less Title Information, Proceeding edited by Robert J. Card, P.E., M.ASCE; and Michael K. Kenny, M.ASCE, Pipelines Conference 2012, Miami Beach, Florida August 19-22, 2012 (<http://content.asce.org/conferences/pipelines2012/>)
- Barlow, P.M., and Leake, S.A., 2012, Streamflow depletion by wells—Understanding and managing the effects of groundwater pumping on streamflow: U.S. Geological Survey Circular 1376, pp. 84 (<http://pubs.usgs.gov/circ/1376/>)
- Galloway, D.L., Bawden, G.W., Leake, S.A. and Honegger, D.G., 2008, Land subsidence hazards, in Baum, R.L., Galloway, D.L., and Harp, E.L., Landslide and land subsidence hazards to pipelines: U.S. Geological Survey Open-File Report 2008-1164, p. 192 (<http://pubs.usgs.gov/of/2008/1164/>)
- Brush, C.F., Dogrul, E.C., and Kadir, T.N., 2013a, DWR Technical Memorandum: Development and Calibration the California Central Valley Groundwater- Surface Water Simulation Model (C2VSim), Version 3.02-CG, This report describes version R374 of the C2VSim-CG model, released in June 2013, pp. 193 (http://baydeltaoffice.water.ca.gov/modeling/hydrology/C2VSim/download/C2VSim_Model_Report_Final.pdf)
- Brush, C.F., Dogrul, E.C., and Kadir, T.N., 2013b, DWR Technical Memorandum: User's Manual for the California Central Valley Groundwater-Surface Water Simulation Model (C2VSim), Version 3.02-CG, This report describes version R374 of the C2VSim-CG model, released in June 2013, pp. 134 (http://baydeltaoffice.water.ca.gov/modeling/hydrology/C2VSim/download/C2VSim_User)

- [s_Manual_Final.pdf](#))
- California Energy Commission, November 2014, Energy Maps of California web site, (<http://www.energy.ca.gov/maps/>)
- CH2MHill, 2010, Technical Memorandum - Groundwater Substitution Transfer Impact Analysis, Sacramento Valley, To: Abdul Khan/California Department of Water Resources and Bob Niblack/California Department of Water Resources, From: Peter Lawson/CH2M HILL, Redding, California, March 29, 2010, Project No. 376301.08.01, pp. 21
- Constantz, J., 2008, Heat as a tracer to determine streambed water exchanges, Water Resources Research, v. 44, W00D10, pp. 20
- Driscoll, F.G., 1986, Groundwater and Wells, Second Edition, Johnson Division, St. Paul, Minnesota, pp. 1089
- Department of Conservation, California Geological Survey, 2010, Fault activity map of California: California Geological Survey Geologic Data Map No. 6, map scale 1:750,000, compilation and interpretation by Jennings, C.W., and Bryant, W.A., (<http://www.quake.ca.gov/gmaps/FAM/faultactivitymap.html>)
- Department of Conservation, Division of Oil, Gas and Geothermal Resources, 2000, Energy Map of California, Third Edition, scale 1:1,000,000, (ftp://ftp.consrv.ca.gov/pub/oil/maps/Map_S-2.pdf)
- Department of Water Resources, 2008, Land Subsidence: What is it and why is it an important aspect of groundwater management?, by Fulton I, A., in cooperation with the California Department of Water Resources, Northern Region, Groundwater Section 2, pp. 4 (<http://www.water.ca.gov/groundwater/docs/WhatIsLandSubsidence.pdf>)
- Department of Water Resources, 2014a, Maps of Domestic Well Depth Summary with Depth to Groundwater Contours for Wells Screened at Depths Less Than 150 Feet, for Butte County, Colusa County, Glenn County, Tehama County, and Redding Basin, Northern Regional Office, January 2014 (http://www.water.ca.gov/groundwater/data_and_monitoring/northern_region/GroundwaterLevel/gw_level_monitoring.cfm#Well%20Depth%20Summary%20Maps)
- Department of Water Resources, 2014b, Northern Sacramento Valley Change in Groundwater Elevation Maps; Shallow Aquifer Zone, (Well depths less than 200 ft bgs), Spring 2013 to Spring 2014, Plate IS-A; Intermediate Aquifer Zone, (Well depths generally greater than 200 ft and less than 600 ft deep bgs), Spring 2013 to Spring 2014, Plate II-B; Deep Aquifer Zone, (Well depths greater than 600 ft bgs) Spring 2013 to Spring 2014, Plate ID-B, (http://www.water.ca.gov/groundwater/data_and_monitoring/northern_region/GroundwaterLevel/gw_level_monitoring.cfm)
- Domenico, P.A., and Schwartz, F.K., 1990, Physical and Chemical Hydrogeology, John Wiley and Sons, pp. 824
- Faunt, C.C., ed., 2009, Groundwater Availability of the Central Valley Aquifer, California: U.S. Geological Survey Professional Paper 1766, pp. 225 (<http://pubs.usgs.gov/pp/1766/>)
- Frind, E.O., Muhammad, D.S., and Molson, J.W., 2002, Delineation of Three-Dimensional Well Capture Zone for Complex Multi-Aquifer Systems, Groundwater, v.40, no. 6, pgs. 586-598

- Franke, O.L., Reilly, T.E., Pollock, D.W., and LaBaugh, J.W., 1998, Estimating Areas Contributing Recharge to Wells, Lessons from Previous Studies, USGS Circular 1174, pp. 14 (<http://water.usgs.gov/ogw/pubs/Circ1174/>)
- Jenkins, C.T., 1968a, Computation of rate and volume of stream depletion by wells: U.S. Geological Survey Techniques of Water-Resources Investigations, book 4, chap. D1, pp. 17 (<http://pubs.usgs.gov/twri/twri4d1/>)
- Jenkins, C.T., 1968b, Techniques for computing rate and volume of stream depletion by wells: *Ground Water*, v. 6, no. 2, p. 37–46
- Kalbus, E., Reinstorf, F. and Schirmer, M., 2006, Measuring methods for groundwater – surface water interactions: a review, *Hydrology and Earth System Sciences*, v. 10, pgs. 873–887 (www.hydrol-earth-syst-sci.net/10/873/2006/)
- Maddock, T., III, and Vionnet, L.B., 1998, Groundwater capture processes under a seasonal variation in natural recharge and discharge, *Hydrogeology Journal*, v. 6, pgs. 24-32
- Miller, C.D., Durnford, D., 2005, Modified use of the “SDF” semi-analytical stream depletion model in bounded alluvial aquifers, in *Hydrology Days 2005*, Colorado State University, Fort Collins, CO, pgs. 146 -159 (http://hydrologydays.colostate.edu/Papers_2005/Miller_paper.pdf)
- Miller, C.D., Durnford, D., Halstead, M.R., Altenhofen, J., and Flory, V., 2007, Stream depletion in alluvial valleys using the SDF semianalytical model, *Ground Water*, v. 45, no. 4, p. 506–514
- Northern California Water Association, 2014a, Sacramento Valley Groundwater Assessment, Active Management – Call to Action, prepared by Davids Engineering, Macaulay Water Resources, and West Yost Associates, June 2014, pp. 20 (<http://www.norcalwater.org/res/docs/NCWA-GW-2014-web.pdf>)
- Northern California Water Association, 2014b, Sacramento Valley Groundwater Assessment, Active Management – Call to Action, Technical Supplement, prepared by Davids Engineering, Macaulay Water Resources, and West Yost Associates, June 2014, pp. 91 (http://www.norcalwater.org/res/docs/NCWA_supp-web.pdf)
- Northern California Water Association, 2014c, Sacramento Valley Water Quality Coalition Groundwater Quality Assessment Report, Final Draft, June 2014, prepared by CH2MHill, pp. 168 (http://www.norcalwater.org/res/docs/NCWA_GWQ_Assessment_7-18-2014_FinalDRAFT.pdf)
- O’Rourke, M.J., and Norberg, C., 1992, Longitudinal Permanent Ground Deformation Effects on Buried Continuous Pipelines, National Center for Earthquake Engineering Research, State University of New York at Buffalo, pgs. 181 (<http://mceer.buffalo.edu/publications/catalog/reports/Longitudinal-Permanent-Ground-Deformation-Effects-on-Buried-Continuous-Pipelines-NCEER-92-0014.html>)
- O’Rourke, M.J., and Liu, X., 1999, Response of Buried Pipelines Subject to Earthquake Effects, Monograph Series No. 3, Multidisciplinary Center for Earthquake Engineering Research, MCEER, Research Foundation of the State University of New York and the Multidisciplinary Center for Earthquake Engineering Research, pp. 249 (<http://mceer.buffalo.edu/publications/catalog/reports/Response-of-Buried-Pipelines-Subject-to-Earthquake-Effects-MCEER-99-MN03.html>)

- O'Rourke, M.J., and Liu, X., 2012, Seismic Design of Buried and Offshore Pipelines, Monograph MCEER-12-MN04, Multidisciplinary Center for Earthquake Engineering Research, MCEER, Research Foundation of the State University of New York and the Multidisciplinary Center for Earthquake Engineering Research, pp. 380 (<http://mceer.buffalo.edu/pdf/report/12-MN04.pdf>)
- Pipeline Research Council International, Inc., 2009, Guidelines for Constructing Natural Gas and Liquid Hydrocarbon Pipelines Through Areas Prone to Landslide and Subsidence Hazards, Final Report, prepared by: C-CORE D.G. Honegger Consulting SSD, Inc., January 2009, pp. 203 (<http://ntl.bts.gov/lib/46000/46300/46316/FilGet.pdf>)
- Rosenberry, D.O., and LaBaugh, J.W., eds., 2008, Field techniques for estimating water fluxes between surface water and ground water: U.S. Geological Survey Techniques and Methods 4–D2, pp. 128 (<http://pubs.usgs.gov/tm/04d02/>)
- Stonestrom, D.A., and Constantz, J., 2003, Heat as a tool for studying the movement of ground water near streams: U.S. Geological Survey Circular 1260, pp. 96 (<http://pubs.usgs.gov/circ/2003/circ1260/>)
- U.S. Environmental Protection Agency, 2008, A Systematic Approach for Evaluation of Capture Zones at Pump and Treat Systems, Project Officer David S. Burden, EPA/600/R-08/003, January 2008, pp. 165 (<http://www.epa.gov/ada/>)
- U.S. Geological Survey, 1984, Hull, L.C., Geochemistry of Ground Water in the Sacramento Valley, California, U.S. Professional Paper 1401-B, pp. 36 (<http://pubs.usgs.gov/pp/1401b/report.pdf>)
- U.S. Geological Survey, 2008, Dawson, B.J., Bennett, G.L., V, and Belitz, Kenneth, 2008, Ground-Water Quality Data in the Southern Sacramento Valley, California, 2005—Results from the California GAMA Program: U.S. Geological Survey Data Series 285, pp. 93 (<http://pubs.usgs.gov/ds/285/ds285.pdf>)
- U.S. Geological Survey, 2010, Thiros, S.A., 2010, Section 13, Conceptual understanding and groundwater quality of the basin-fill aquifer in the Central Valley, California; *in* Thiros, S.A., Bexfield, L.M., Anning, D.W., and Huntington, J.M., eds., 2010, Conceptual understanding and groundwater quality of selected basin-fill aquifers in the Southwestern United States: U.S. Geological Survey Professional Paper 1781, pgs. 267–287 (<http://pubs.usgs.gov/pp/1781/pdf/pp1781.pdf>)
- U.S. Geological Survey, 2011, Bennett, G.L., V, Fram, M.S., and Belitz, Kenneth, 2011, Status of groundwater quality in the Southern, Middle, and Northern Sacramento Valley study units, 2005–08—California GAMA Priority Basin Project: U.S. Geological Survey Scientific Investigations Report 2011–5002, pp. 120 (<http://pubs.usgs.gov/sir/2011/5002/pdf/sir20115002.pdf>)
- Wallace, R.B., Yakup, D., and Annable, M.D., 1990, Stream depletion by cyclic pumping of wells, Water Resources Research, v. 26, no. 6, pgs. 1263–1270 (<http://www.hydra.iwr.msu.edu/iwr/cv/proposals/publications/documents/1990/Stream%20Depletion%20by%20Cyclic%20Pumping%20of%20Wells%20Vol%206%20No%206%20une%201990.pdf>)
- Zamora, C., 2008, Estimating Water Fluxes Across the Sediment–Water Interface in the Lower Merced River, California: U.S. Geological Survey Scientific Investigations Report 2007–5216, pp. 47 p. (Available at <http://pubs.usgs.gov/sir/2007/5216/>)

List of Exhibits

- 1.1 – Figure 16 from Barlow and Leake, 2012
- 1.2 – Figure 29 from Barlow and Leake, 2012
- 2.1 – Composite map of domestic wells, < 150 ft. bgs depth summary maps for northern Sacramento Valley (DWR, 2014a) and traced shallow zone, well depths < 200 ft. bgs., 2004 to 2014 changes in groundwater elevation (DWR, 2014b)
- 3.1 – Composite plot of DWR’s spring 2004 to spring 2014 groundwater elevation change maps for shallow aquifer zone, well depths less than 200 feet bgs, and Draft EIS/EIR SACFEM2013-1990 hydrologic conditions simulations shown in Figures 3.3-29, aquifer depth approximately 35 feet
- 3.2 – Composite plot of DWR’s spring 2004 to spring 2014 groundwater elevation change maps for intermediate aquifer zone, well depths greater than 200 feet and less than 600 feet bgs, and Draft EIS/EIR SACFEM2013-1990 hydrologic conditions simulations shown in Figures 3.3-30, aquifer depth approximately 200 to 300 feet
- 3.3 – Composite plot of DWR’s spring 2004 to spring 2014 groundwater elevation change maps for deep aquifer zone, well depths greater than 600 feet bgs, and Draft EIS/EIR SACFEM2013-1990 hydrologic conditions simulations shown in Figures 3.3-31, aquifer depth approximately 700 to 900 feet
- 4.1 – Summary Table of Sacramento Valley Groundwater Model Parameters
- 4.2 – Table 5, Brush and others, 2013a, C2VSim model parameter ranges
- 4.3 – Table C8, Faut, ed., 2009, CVHM model, measured and simulated hydraulic properties
- 4.4 – Figure 3, Brush and others, 2013a, C2VSim model subregions and hydrologic regions
- 4.5 – Table A1, Faut, ed., 2009, CVHM Water-balance subregions within the Central Valley, California
- 4.6 – Appendix 16.D, Driscoll, 1986, Empirical equations used to estimate specific capacity and transmissivity
- 4.7a to k – Figures A10A and B (a, b), A12A to E (c to g), A13 (h), A14 (i), C14 (j) and A15 (k) from Faut, ed., 2009, CVHM model parameters
- 4.8 a to f – Figures 34A to C (a, b, c), 35A to C (d, e, f), 37A to C (g, h, i), 38A and B(j, k), 39A and B (l, m), page 92 (n) from Brush and others, 2013a, and page 154 (o) from Faut, ed., 2009
- 5.1 – Page 100 from Brush and others, 2013a
- 5.2 – Figure 40, River-bed conductance from Brush and others, 2013a
- 5.3 – Figure C26, Distribution of cells used for streams, streambed hydraulic conductivity values from Faut, ed., 2009
- 5.4a, b – Figure C19A and B (a, b), Distribution of stream gain/loss segments used for model calibration, measured and simulated from Faut, ed., 2009
- 6.1a to c – Figure 81A to C (a, b, c), Simulated average annual subsurface flows between subregions from Brush and others, 2013a
- 6.2 – Figure 39, Simulated net annual subsurface flow between hydrologic regions for water years 2000-2009 from Brush and others, 2013b
- 6.3a to d – Tables 10 to 13 (a, b, c, d), Central Valley basin flows from the C2VSim model from Brush and others, 2013a
- 7.1 – Table summarizing the range of the number of wells in that lie within the spring 2004 to spring 2014 shallow aquifer zone drawdown contours in northern Sacramento Valley from DWR, 2014a and DWR, 2014b (see Exhibit 2.1 for composite map)

- 8.1a to c – Shallow (a), intermediate (b) and deep (c) composite maps of spring 2004 to spring 2014 groundwater elevation changes in northern Sacramento Valley (DWR, 2014b) with California natural gas pipelines map by California Energy Commission (Exhibit 8.6)
- 8.2 – Intermediate spring 2004 to spring 2014 groundwater elevation changes in northern Sacramento Valley (DWR, 2014b) with DWR's GPS subsidence grid (DWR, 2008)
- 8.3 – Figure B15A, Areal extent of land subsidence in the Central Valley from Faunt, ed., 2009
- 8.4 – Figure 6, Extensometer and GPS survey locations in the Sacramento Valley from DWR, 2008
- 8.5 – Energy Map of California, Map S-2, 2000, California Department of Conservation, Division of Oil, Gas and Geothermal Resources
- 8.6 – California Natural Gas Pipelines map by California Energy Commission
- 8.7 – California Natural Gas Pipelines and Storage Facilities map by California Energy Commission
- 8.8 – California Oil Refineries and Terminals map by California Energy Commission
- 8.9 – California Natural Gas Pipelines – Oil Refineries and Terminals map by California Energy Commission
- 8.10 – California Power Plants map by California Energy Commission
- 8.11 – Electric Generation Facilities and Projects Reviewed by the California Energy Commission, 1976 to July, 2014 map by California Energy Commission
- 9.1 – Figure C1-A, Central Valley Hydrologic Model grid, with horizontal flow barrier from Faunt, ed., 2009
- 9.2 – Page 160 from Faunt, ed., 2009
- 9.3a, b – Pages 203 (a) and 204 (b) from Faunt, ed., 2009
- 9.4a to d – Four screen prints of CGS's 2010 Fault Activity Map of California web site, accessed October 31, 2014
- 9.5 – Explanation for 2010 Fault Activity Map of California
- 9.6 – An Explanatory Text to Accompany the Fault Activity Map of California, first 12 pages
- 10.1 – Table B3 from Faunt, ed., 2009
- 10.2a to c – Figures B9 (a), B10-A (b) and B10-B (c) from Faunt, ed., 2009
- 10.3 – Figure 83 from Brush and others, 2013a
- 10.4 – Figure 35 from Brush and others, 2013b
- 10.5a to c – Tables 3-6 (a), 3-7 (b) and 3-8 (c) from NCWA, 2014b
- 10.6a to g – Figures 3-19 (a), 3-20 (b), 3-22 (c), 3-24 (d), 3-26 (e), 3-27 (f), and 3-29 (g) from NCWA, 2014b
- 10.7 – Composite of Figures 3-22, 3-24 from NCWA, 2014b, and Figure 35 from Brush and others, 2013b
- 10.8 – Figure 2-4 from Brush and others, 2013b
- 10.9 – Figure 2-5 Brush and others, 2013b
- 11.1 – Figure 1 from Miller and Durnford, 2005
- 11.2 – Table 3 from Wallace and others, 1990
- 11.3a to c – Figures 4 (a), 5 (b) and 6 (c) from CH2MHill, 2010
- 12.1 – Annotated bibliography of reports relevant to groundwater resource assessment in the Sacramento Valley provided by Nora and Jim, researchers with AquAlliance, 11 pages
- 12.2 – List of permits to replace dry wells in Shasta County provided by B. Smith, researcher with AquAlliance, 2 pages

Critique of Long-Term Water Transfers Environmental Impact Statement/Environmental Impact Report Public Draft

Economic Issues

December 1, 2014

Prepared for:

AquAlliance

Contact Information

Mark Buckley, Lizzie Gooding, Ed MacMullan, and Sarah Reich prepared this report. ECONorthwest is solely responsible for its content.

ECONorthwest specializes in economics, planning, and finance. Established in 1974, ECONorthwest has over three decades of experience helping clients make sound decisions based on rigorous economic, planning and financial analysis.

For more information about ECONorthwest, visit our website at www.econw.com.

For more information about this report, please contact:

Ed MacMullan

ECONorthwest
72 West Broadway, Suite 206
Eugene, OR 97401
541-687-0051
macmullan@econw.com

Table of Contents

Executive Summary	ES-1
1 Introduction and Context.....	1
2 The LTWT ignores relevant background information about the affected environment that would have helped inform the analysis	3
3 The LTWT relies on outdated and incomplete data	13
4 The LTWT underestimates negative impacts on the regional economy in the sellers area.....	20
5 The LTWT finds significant negative effects but the vague and incomplete proposed monitoring and mitigation plans would not address these effects	24
6 The LTWT ignores the economic costs of environmental externalities and subsidies that water transfers support.....	29
7 The LTWT underestimates the cumulative effects of water transfers.....	33

Executive Summary

The US Bureau of Reclamations and San Luis & Delta-Mendota Water Authority released the Public Draft of the *Long-Term Water Transfers Draft Environmental Impact Statement/Environmental Impact Report* (LTWT) in September 2014. The purpose of the LTWT, as we understand, is to evaluate the potential impacts of three proposed water-transfer alternatives, as well as a no action alternative. AquaAlliance asked ECONorthwest to critique and provide written comments on the LTWT.

01

In general, the analysis described in the LTWT suffers from significant omissions and errors. These omissions and errors matter. As written the report provides stakeholders and decisions makers with a biased and incomplete description of the environmental and economic consequences of water transfers. In the following sections of this report we describe our critiques in detail. Our major critiques include the following.

The LTWT ignores relevant background information about the affected environment that would have helped inform the analysis. The LTWT provides a cursory description of the relevant affected environment that paints an incomplete picture of the context within which water transfers would happen. A more complete, accurate and up-to-date description would have included, for example: information from the many recent reports on California's climate and groundwater conditions; current data on water transfers; and, a market analysis of water prices, prices for agricultural commodities and how price changes influence the number and volumes of water transfers. As such, the deficient description is the shaky foundation upon which a lacking analysis rests. The resulting effort yields questionable results regarding the likely future frequency and amounts of water transfers and their environmental and economic consequences.

02

The LTWT relies on outdated and incomplete data. The analysis described in the LTWT relies on obsolete data for certain key variables and ignored other relevant data and information. For example, the analysis assumes a price for water that bears no resemblance to the current reality. It also ignored relevant research results on the impacts of groundwater pumping on stream flow depletion and the current status of groundwater levels as provided by monitoring wells. The water transfers at issue in the LTWT would not happen in an economic vacuum. Growers and water sellers and buyers react to changing prices and market conditions. The analysis described in the LTWT, however, is silent on these forces and how they would influence water transfers.

03

The LTWT underestimates negative impacts on the regional economy in the sellers area. The LTWT acknowledges that negative economic impacts would be worse if water transfers happen over consecutive years. The analysis, however, estimates impacts for single-year transfers, ignoring the data on the frequency of recent consecutive-year transfers. The analysis also fails to address the extent to which water transfers cause economic harm to water-based recreational activities.

04

The LTWT finds significant negative effects but the vague and incomplete proposed monitoring and mitigation plans would not address these effects. The LTWT proposed both a monitoring and

05

mitigation program for significant negative impacts. Implementing these programs would take planning, effort and financial resources on the part of sellers, injured third parties, and regulatory agencies. The LTWT does not include these costs. The monitoring program is vague and depends on potential sellers implementing the program. This conflict of interest pits financial gain from water sales against complete and impartial monitoring efforts. This opens the door to lax, biased, or incomplete monitoring, which could lead to negative environmental and economic consequences for third parties. The monitoring program includes monitoring subsidence, however, the program is vague on requirements and what amount of subsidence would trigger a halt in water transfers. Injured third parties would bear the costs of bringing to the sellers' attention harm caused by groundwater pumping. The analysis described in the LTWT assumes that disagreements regarding third-party damages would be settled cooperatively between third parties and sellers, without presenting evidence substantiating such an optimistic assumption. The LTWT is silent on the economic consequences of sellers and injured third parties not cooperatively agreeing on harm and compensation.

05

The LTWT ignores the environmental externalities and economic subsidies that water transfers support. The LTWT lists Westlands Water District as one of the CVP contractors expressing interest in purchasing transfer water. The environmental externalities caused by agricultural production on Westlands are well documented, as are the economic subsidies that support this production. To the extent that the water transfers at issue in the LTWT facilitate agricultural production on Westlands, they also contribute to the environmental externalities and economic subsidies of that production. The LTWT is silent on these environmental and economic consequences of the water transfers.

06

The LTWT underestimates the cumulative effects of water transfers. Cumulative effects analyses under NEPA and CEQA are intended to identify impacts that materialize or are compounded when the proposed action is implemented at the same time as or in conjunction with other actions. The LTWT addresses cumulative effects for each resource area and provides a global description of the methods and actions considered for analysis in each resource area. The analysis, however, provides cursory discussion of potential cumulative effects for the regional economy, and ignores the full range of possible cumulative outcomes associated with the proposed transfer

07

1 Introduction and Context

The US Bureau of Reclamations (BOR) and San Luis & Delta-Mendota Water Authority (SLDMWA) released the public draft of the *Long-Term Water Transfers Draft Environmental Impact Statement/Environmental Impact Report* (LTWT) in September 2014. The LTWT covers water transfers that would happen between 2015 through 2024. Because the transfers would use federal and state infrastructure, the LTWT must comply with NEPA and CEQA guidelines. BOR is the lead agency regarding NEPA requirements, and SLDMWA is the lead agency for CEQA requirements.¹

The premise underlying the proposed water transfers is that sellers, mostly in the Sacramento Valley, would idle cropland, switch to less water-intensive crops, and/or substitute groundwater for surface water, and send the surface water they would otherwise have used through the Bay Delta to buyers in the south.

The proposed transfers would happen within a context of environmental conditions that both highlight the increasing demand for water throughout California and raise concerns regarding the environmental and economic effects of the water transfers at issue in the LTWT. These conditions include:

- Current drought conditions of historic proportion coming on the heels of consecutive dry years.
- Increasing concerns over the demands on groundwater and groundwater conditions throughout the state, including in the Sacramento Valley.
- Increasing competition for water from all user groups including agricultural, municipal and industrial users, and environmental requirements that help protect habitats and water quality.

Within this context, regulatory agencies face increasing demands from stakeholders for transparent decisions that rely on the best available science and information when balancing competing demands. For example, the relevant NEPA requirements for the LTWT analysis include:

“Rigorous exploration and objective evaluation of all reasonable alternatives, ...”²

AquAlliance asked ECONorthwest to review the LTWT and provide comments on the extent to which the analysis described in the report fulfills the NEPA requirement. We describe the results of our initial review and critique of the document in this report. The relatively short

¹ LTWT, page 1-1, 2-1.

² LTWT page 2-1.

public comment period limited the extent of our review. Should the comment period be extended or reopened, we may expand and revise our comments.

The remainder of our report is as follows. In the next section, Section 2, we comment on the LTWT's incomplete description of the affected environment within which the water transfers would happen. We cite sources with relevant information that if included would yield a more complete and comprehensive description of the affected environment.

In Section 3 we highlight deficiencies in the data and analysis described in the LTWT. For example, we note that the model relies on outdated prices for water and agricultural commodities—two central components of the analysis. The analysis also estimates that water transfers would happen in a static environment where water prices and commodity prices remain fixed. These conditions do not reflect the dynamic reality of water demands and use.

In Section 4 we note instances in which the analysis described in the LTWT underestimates the impacts of water transfers on the regional economy in the source-water areas.

In Section 5 we draw attention to some of the deficiencies of the proposed monitoring and mitigation programs that the LTWT's authors claim will adequately address any negative effects of the transfers. These deficiencies include the inherent conflicts of interests in the programs, excluding the costs of the programs, and vague and ill-defined critical components of the programs.

In Section 6 we describe some of the environmental and economic externalities associated with the use of the transferred water.

In Section 7, we list some of the deficiencies in the analysis of cumulative effects. For example, the analysis ignores the impacts of transfers that would happen in addition to those at issue in the LTWT.

08

2 The LTWT ignores relevant background information about the affected environment that would have helped inform the analysis

The LTWT provides a cursory description of the relevant affected environment that paints an incomplete picture of the context within which water transfers would happen. A more complete, accurate and up-to-date description would have included, for example: information from the many recent reports on California’s climate and groundwater conditions; current data on water transfers; and, a market analysis of water prices, prices for agricultural commodities and how price changes influence the number and volumes of water transfers. As such, the deficient description is the shaky foundation upon which a lacking analysis rests. The resulting effort yields questionable results regarding the likely future frequency and amounts of water transfers and their environmental and economic consequences.

Specific concerns regarding the LTWT’s incomplete description of the affected environment in the Sacramento Valley include the following.

Incomplete description of current climate conditions

According to the California Department of Water Resources (DWR), 2013 was the driest year on record for many parts of the state.³ Such drought conditions are one reason given for why growers and municipal and industrial (M&I) users in the south would purchase water from other parts of California. The analysis described in the LTWT fails to acknowledge, however, that other parts of the state, including the Sacramento Valley, also feel the effects of drought. How agricultural and M&I water users in the north respond to recent drought conditions would affect water transfers. The authors of the LTWT exclude these factors from their analysis.

For example, in a recent letter to the BOR, the Glenn-Colusa Irrigation District (GCID) indicated they were developing a groundwater supplemental supply program and that developing this program takes priority over participating in water transfers as described in the LTWT.

“GCID’s position is that it will pursue, as a priority, the proposed Groundwater Supplemental Supply Program over any proposed transfer program within the region, including Reclamation’s Long-Term Water Transfer Program (LTWTP).”

³ California Department of Water Resources (DWR). 2014a. *Public Update for Drought Response Groundwater Basins with Potential Water Shortages and Gaps in Groundwater Monitoring*. April 30. Page ii.

“... It is important to underscore that GCID would prioritize pumping during dry and critically dry water years for use in the Groundwater Supplemental Supply Program, and thus wells used under that program would not otherwise be available for USBR’s LTWTP.”⁴

GCID’s focus on its own groundwater program over BOR water transfers is notable because the LTWT lists GCID as a potential seller with the largest volume of water for sale, 91,000 af.⁵ GCID’s reasons for pursuing its groundwater supply program include concerns over water availability during dry years.

“The primary objective is to develop a reliable supplemental water source for GCID during dry and critically dry years. The proposed goals are as follows:

- Increase system reliability and flexibility
- Offset reductions in Sacramento River diversions by GCIS during drought years to replace supplies for crops and habitat
- Periodically reduce Sacramento River diversions to accommodate fishery and restoration flows
- Protect agricultural production”⁶

A related point is that the LTWT fails to discuss the possibility that current climate and water conditions may represent a new benchmark rather than a deviation from past trends. The increasing number of years with water transfers (described below), and reports on climate change and its impacts on water conditions, are two arguments in support of exploring this point. For example, according to a report commissioned by the Northern California Water Association (NCWA),

“This year [2014] we face unprecedented drought conditions, following a decade of relatively dry years and increased demands on our groundwater resources. These increased demands have two principal causes. The reduced availability of surface water during dry years brings a predictable shift towards greater use of groundwater. The second is expanding and intensifying agricultural land use within the Sacramento Valley, together with increasing urban water demands, leading to increased reliance on groundwater even in ‘normal’ years.”⁷

⁴ Bettner, T. 2014. *Letter to Brad Hubbard, Bureau of Reclamation re Draft EIS/EIR on Proposed Long-Term Water Transfer Program*. Glenn-Colusa Irrigation District. October 14. Pages 1 and 3.

⁵ LTWT, Table 2-4, page 2-14.

⁶ Bettner, 2014, page 2.

⁷ Davids Engineering, Macaulay Water Resources, and West Yost Associates (DMW). 2014. *Sacramento Valley Groundwater Assessment Active Management – Call to Action*. Prepared for Northern California Water Association. June. Page 2.

Fails to consider concerns regarding the oversubscription of water resources

The analysis described in the LTWT fails to acknowledge the problem of supporting water transfers using “paper water,” or oversubscribed water in the Sacramento Valley. A report on water transfer issues in California describes one aspect of this problem.

“The inability of interested parties to agree on the volume of transferable water associated with the short-term fallowing of agricultural lands has caused substantial controversy and delays in approving certain water transfer proposals. The primary issue for interested parties is whether a fallowing-based transfer proposal would actually increase the burden on the CVP and SWP to maintain water quality and flow conditions in downstream portions of the Sacramento River and Delta because upstream transfer proponents were allowed to transfer what might prove to be ‘paper’ water.”⁸

12

Stakeholders in the Sacramento Valley concerned about this problem researched the extent of paper water and found that rights to water significantly exceed available supply. Testimony by the California Water Impact Network submitted to the State Water Resources Control Board concluded that, “The ratio of total consumptive use claims to average unimpaired flow in the Sacramento River Basin is about 5.6 acre-feet of claims per acre-foot of unimpaired flow.”⁹ Thus, claims on water in the Sacramento Valley significantly exceed the available supply.

Incomplete description of current groundwater conditions

The LTWT excluded current information on groundwater conditions in the Sacramento Valley. This information includes concerns regarding historically low groundwater levels in certain areas of the Sacramento Valley, related concerns over subsidence caused by depleted groundwater, and a lack of groundwater monitoring information.

13

According to the DWR, groundwater levels are decreasing through out California, including in the Sacramento Valley. Groundwater levels decreased since the spring of 2013, and “notably” since the spring of 2010.¹⁰ A related point, according to the DWR, is that there are “significant” gaps in groundwater monitoring data for areas throughout the state, including the Sacramento Valley.¹¹ There’s also a lack of understanding

⁸ The Water Transfer Workgroup. 2002. Water transfer issues in California. Final Report to the California State Water Resources Control Board. June, page 20.

⁹ Stroshane, T. 2012. *Testimony on water availability analysis for Trinity, Sacramento, and San Joaquin River basins tributary to the Bay-Delta Estuary*. October 26. California Water Impact Network. For Workshop #3 Analytical Tools for Evaluating the water Supply, Hydrodynamic, and Hydropower Effects of the Bay-Delta Plan November 13 and 14, 2012. Page 11.

¹⁰ DWR, 2014a, page ii.

¹¹ DWR, 2014a, page ii.

regarding groundwater recharge and interactions between surface and groundwater in the Sacramento Valley. According to the NCWA report,

“[G]roundwater changes can take many years to become apparent, and we have not yet been able to measure with certainty the long-term impacts of the current level of groundwater use as it affects our measures of sustainability.”

13

“Persistently declining groundwater levels in many areas of the Sacramento Valley over the past decade reveal that groundwater discharge exceeds recharge. Simply put: if the objective is to stem or reverse the trend, the groundwater balance must be adjusted either by putting more water into the ground or taking less out.”¹²

According to the DWR, the Sacramento River hydrologic region has 23 groundwater basins ranked “high” or “medium” as described by the CASGEM groundwater basin prioritization study. These rankings describe a groundwater basin’s importance in meeting demands for urban and agricultural water use. The San Joaquin River hydrologic region has nine “high,” or “medium” ranked basins.¹³

A recent report from Glenn County indicates that current groundwater levels in the county are at the lowest levels recorded going back to the start of record keeping in the 1920s.

“Data in reference to groundwater levels has been collected from both private and dedicated monitoring wells located within Glenn County, in some cases dating as far back as the 1920’s. The lowest levels in these wells were most frequently associated with measurements from the 1976-77 monitoring period, which coincided with one of the more severe droughts in California’s history. In the years following the 76-77 drought, groundwater levels often approached these historic lows but rarely fell below them. However, recent (2012-13) data indicate levels in many wells have declined below those historic thresholds and are now at the lowest levels observed since monitoring began.”¹⁴

14

“Readily available monitoring data obtained through DWR’s California Statewide Groundwater Elevation Monitoring (CASGEM) is available for 100 wells, and of those 100, 21 still show their lowest levels as occurring in 1977, while 21 had an all-time low water surface elevation level in 2013, and an

¹² DMW, 2014, page 10.

¹³ DWR, 2014b. *California Groundwater Elevation Monitoring Basin Prioritization Process*. June. Page 5.

¹⁴ Glenn County Water Advisory Committee, Ad-hoc Committee. 2014. *Report on Groundwater Level Declines in Western Glenn County*. May 6. Page 5.

additional 15 wells reached their lowest point in 2009-2012. Therefore, one out of every five monitored wells in the area was at its lowest-ever recorded level in 2013, and one out of every three wells monitored in the area was at its lowest-ever recorded level between 2009 and 2013.”¹⁵

14

Regarding the limited groundwater modeling described in the LTWT, consulting hydrologist Kit Custis comments,

“Because the groundwater modeling effort [described in the LTWT] didn’t include the most recent 11 years record, it appears to have missed simulating the most recent periods of groundwater substitution transfer pumping and other groundwater impacting events, such as recent changes in groundwater elevations and groundwater storage [citation omitted], and the reduced recharge due to the recent periods of drought. Without taking the hydrologic conditions during the recent 11 years into account, the results of the SACFEM2013 model simulation may not accurately depict current conditions or predict the effects from the proposed groundwater substitution transfer pumping during the next 10 years.”¹⁶

15

The DWR reports that areas of the Sacramento Valley are at risk for subsidence from depleted groundwater. Most of the groundwater basins susceptible to future subsidence are also ranked “high” and “medium” priority by the CASGEM groundwater basin prioritization analysis. According to the DWR and based on data from 2008 through 2014, approximately 36 percent of long-term wells surveyed in the Sacramento Valley are at or below the historical spring low levels. Another measure indicates that 50 percent of groundwater levels in 18 groundwater basins in the Sacramento Valley are at or below historical spring low levels.¹⁷ A white paper by a consulting engineer on groundwater use and subsidence in the Sacramento Valley noted that subsidence may happen years after groundwater pumping and that real-time monitoring of groundwater pumping “will generally tend to underestimate the long-term settlement of the ground surface.”¹⁸

16

Subsidence can cause substantial economic harm. According to a report by consulting engineers studying subsidence in California,

¹⁵ Glenn County Water Advisory Committee, Ad-hoc Committee. 2014. *Report on Groundwater Level Declines in Western Glenn County*. May 6. Page 6.

¹⁶ Custis, K. 2014. *Letter to Barbara Vlamis*, November 10. RE: Comments and recommendations on U.S. Bureau of Reclamation and San Luis & Delta-Mendota Water Authority Draft Long-Term Water Transfer DRAFT EIS/EIR, dated September 2014. Page 5.

¹⁷ DWR, 2014c. *Summary of Recent, Historical, and Estimated Potential for Future Land Subsidence in California*. Pages 9, 11.

¹⁸ Mish, D. 2008. *Commentary on Ken Loy GCID Memorandum*. Page 4.

“Land subsidence has been discovered in many areas of the state, causing billions of dollars of damage. Impacts from subsidence fall into the following categories:

- Loss of conveyance capacity in canals, streams and rivers, and flood bypass channels;
- Diminished effectiveness of levees;
- Damage to roads, bridges, building foundations, pipelines, and other surface and subsurface infrastructure; and
- Development of earth fissures, which can damage surface and subsurface structures and allow for contamination at the land surface to enter shallow aquifers.”¹⁹

16

Subsidence in Colusa, Yolo and Solano counties in the Sacramento Valley during the 1976-77 drought caused widespread well casing damages, which made some wells unusable.²⁰ A recent series of reports by the Stanford Woods Institute for the Environment and the Bill Lane Center for the American West at the Water in the West center at Stanford University describe the subsidence concerns regarding groundwater pumping in California, including the Sacramento Valley.²¹ Custis notes the types of infrastructure in the Sacramento Valley susceptible to damage from subsidence,

17

“There are a number of critical structures in the Sacramento Valley that may be susceptible to settlement and lateral movement. These include natural gas pipelines, gas transfer and storage facilities, gas wells, railroads bridges, water and sewer pipelines, water wells, canals, levees, other industrial facilities.”²²

In response to concerns over groundwater use and related issues, the California legislature recently passed, and Governor Brown signed into law, the Sustainable Groundwater Management Act (Act).²³ The Act will affect groundwater users including those supplying water transfers. The LTWT makes no mention of how the Act could affect the context within which water transfers would happen, or the transfers themselves. This is a significant omission.

18

¹⁹ Borchers, J. and M. Carpenter. 2014. *Land Subsidence from Groundwater Use in California*. Luhdorff & Scalmanini Consulting Engineers. Support provided by the California Water Foundation. April. Page ES-2.

²⁰ Borchers, J. and M. Carpenter. 2014. *Land Subsidence from Groundwater Use in California*. Luhdorff & Scalmanini Consulting Engineers. Support provided by the California Water Foundation. April. Page ES-3.

²¹ Water in the West. 2014. *Understanding California's Groundwater*. waterinthewest.stanford.edu.

²² Custis 2014, page 28.

²³ opr.ca.gov/s_groundwater.php.

Carriage Water Costs

The LTWT assumes that required carriage water component of water transfers from the Sacramento River will account for 20 percent of transferred water.

“Transfers from the Sacramento Rive assume a 20 percent carriage water adjustment to maintain Delta salinity.”²⁴

Recent data on the percentage of required carriage water are higher than the 20-percent assumption in the LTWT. For example, the DWR describes a recent carriage water percentage of 30.

“Another cost related to transferring water is carriage water. ... For the Sacramento River, this has generally been about 20 percent of the transfer water ... It is worth noting, however, that in 2012 and 2013 carriage water losses for the Sacramento River were as high as 30 percent of transfer water.”²⁵

To the extent that carriage water requirements exceed 20 percent, the LTWT overestimates the amount of water delivered south through the Bay Delta to water purchasers, and thus the economic benefits of these transfers.

Data and modeling ignore recent trends in water transfers

Using water data from 1970 through 2003, the LTWT estimates that future water transfers will happen on average 12 out of 33 years.²⁶ Twelve of 33 years is a transfer probability of approximately 36 percent. By ignoring water data for years after 2003, the analysis excludes relevant information on the more recent dry trend and current historical drought. For example, Table 1-3 on page 1-17 of the LTWT lists years and amounts of water transfers from 2000 through 2014. This data shows that water transfers happened in 9 of the previous 15 years, or a transfer probability of 60 percent, almost double that used in the LTWT. For years after 2003, transfers happened in eight out of 11 years, for a transfer percent of approximately 73.

Other sources of data on the frequency of water transfers do not support the LTWT’s water-transfer results. For example, a report by the Western Canal Water District (WCWD) includes a table showing water transfers from the Sacramento Valley through the Bay Delta from 2001 through projected 2010. The information in this table shows transfers happening in eight out of ten years.²⁷ A similar report by WCWD in 2014

²⁴ LTWT page B-18.

²⁵ California Department of Water Resources. 2013. California Water Plan 2013 Update. Bulletin 160-13. Volume 3 Resource Management Strategies. Pages 8-9.

²⁶ LTWT, page 3.3-60 and -61.

²⁷ Western Canal Water District (WCWD). 2009. *Initial Study and Proposed Negative Declaration for Western Canal Water District 2010 Water Transfer Program*. Western Canal Water District, Richvale, California. January. Page 25.

included a table of water transfers for years 2006 through projected 2014. The data in that table shows transfers happening during seven of nine years.²⁸ Taken together, these two reports show water transfers from the Sacramento Valley south through the Bay Delta in 11 out of 14 years between 2001 through 2014. This works out to a transfer probability of approximately 79 percent.

20

These results demonstrate two important points. First, using a transfer probability of 36 percent greatly underestimates the actual years that transfers happened post-2003, the last year of data in the LTWT analysis. Underestimating transfers leads to underestimating the environmental and economic effects of the transfers.

Second, the data upon which conclusions in the LTWT rest do not depict actual conditions post-2003. That is, by relying on flawed or incomplete data, models that use this data produce flawed or biased results. The estimated transfer frequency (36 percent of years), does not match the recent actual transfer frequency (60, 73, or 79 percent, depending on the source and years included).

21

At an October 21st, 2014 public hearing in Chico, California on the LTWT, a consultant working with BOR on the LTWT commented on the water model and the 1970 through 2003 data upon which the model relies. In response to questions about why the model did not include data from the previous ten years, or why the period of analysis was not extended out to the current drought situation, the consultant replied that the modeling tools “are not up-to-date.”²⁹

According to resource agencies in California, variable, even extreme climate and rainfall conditions are the norm. Climate change is projected to make these trends worse and increase prediction uncertainties. The recent Bay Delta Conservation Plan describes this uncertainty,

“Variability and uncertainty are the dominant characteristics of California’s water resources.”³⁰

22

“Precipitation is the source of 97% of California’s water supply. It varies greatly from year to year, by season, and by where it falls geographically in the state.

²⁸ WCWD. 2014. *Initial Study and Proposed Negative Declaration for Western Canal Water District 2014 Water Transfer Program*. Western Canal Water District, Richvale, California. February. Page 25.

²⁹ Transcript of October 21, 2014 public hearing in Chico, California on the LTWT EIS/EIR; Hacking, H. 2014. “Sacramento Valley water transfer idea leaves locals fuming.” *ChicoER News*, October 22, 2014, <http://www.chicoer.com>.

³⁰ California Department of Water Resources (DWR). 2013. Bay Delta Conservation Plan. Public Draft. November Sacramento, CA. Prepared by ICF International (ICF 00343.12). Sacramento, CA. Page 5-1.

With climate change, the state's precipitation is expected to become even more unpredictable."³¹

"However, the total volume of water the state receives can vary dramatically between dry and wet years. California may receive less than 100 MAF of water during a dry year and more than 300 MAF in a wet year (Western Regional Climate Center 2011)."³²

"The geographic variation and the unpredictability in precipitation that California receives make it challenging to manage the available runoff that can be diverted or captured in storage to meet urban and agricultural water needs."³³

"Historically, precipitation in most of California has been dominated by extreme variability seasonally, annually, and over decade time scales; in the context of climate change, projections of future precipitation are even more uncertain than projections for temperature. Uncertainty regarding precipitation projections is greatest in the northern part of the state, and a stronger tendency toward drying is indicated in the southern part of the state."³⁴

Consultants working for the BOR admit that the water model and data upon which the LTWT analysis and conclusions rest are not up to date. We note above the model's unreliability and poor projection capabilities regarding water transfers post-2003. The DWR concludes that variability and extremes characterize the state's weather and rainfall conditions, and that climate change is increasing this variability and uncertainty. Taken together, these facts raise questions regarding the veracity of the projected water transfers described in the LTWT, and the estimated environmental and economic consequences of those transfers.

The analysis does not adequately take into account recent trends in agricultural production

Not included in the LTWT's description of current conditions are recent trends in agricultural production that affect groundwater use and conditions in the Sacramento Valley. For example, according to a recent report, approximately half the increase in irrigated acres in the Sacramento Valley since 2008 (approximately 200,000 acres), happened on lands not served by surface water suppliers. Irrigating these lands takes approximately 300,000 acre-feet (af) of groundwater per year.³⁵

³¹ DWR, 2013. Page 5-2.

³² DWR, 2013, page 5-2.

³³ DWR, 2013, page 5-2.

³⁴ DWR, 2013, page 5-2.

³⁵ DMW, 2014, page 7.

22

23

A related point is the lack of discussion or analysis in the LTWT of trends in prices for agricultural goods produced with surface and groundwater, trends in prices for water, and how these factors affect grower decisions. For example, the analysis fails to address the extent to which historically high prices for water (discussed below) increase groundwater mining and sale in the Sacramento Valley, and how this affects water transfers and their environmental and economic consequences.

24

Another agricultural trend not discussed in the LTWT, but which has implications for water transfers and their consequences, is the increasing use of pressurized irrigation methods in the Sacramento Valley. Pressurized irrigation reduces groundwater recharge by limiting water percolation. Some growers supply their pressurized irrigation systems using groundwater, even when they have access to surface water. According to the report commissioned by the NCWA,

25

“The increasing use of pressurized irrigation systems using groundwater is likely to be an increasingly important factor in the overall management of groundwater and surface water in the Sacramento Valley as a whole, particularly as such system displace the use of available surface water.”³⁶

In response to the recent trend in high prices for almonds, olives, walnuts and other tree crops, growers in the San Joaquin *and* Sacramento Valleys planted more acres of these trees and other permanent-type crops, and less acres of lower valued annual crops. Such a change increases and “hardens” demand for water in both valleys because growers no longer have the flexibility of idling these acres in response to drought.³⁷ Thus, one of the arguments in support of water transfers—that growers south of the Bay Delta planted increased acres of tree crops that have higher water demands—also affects growers and water use and demands north of the Bay Delta.

26

The LTWT is silent on these trends or how they would influence future water transfers from the Sacramento Valley.

³⁶ DMW, 2014, page 8.

³⁷ DMW, 2014, page 7.

3 The LTWT relies on outdated and incomplete data

In addition to the deficiencies described in previous sections, the analysis described in the LTWT relies on obsolete data for certain key variables. The analysis also ignored other relevant data and information. These shortcomings include the following.

The LTWT assumes a price for water that bears no resemblance to the current reality

The analysis described in the LTWT assumes a price of water of \$225 per af of water.³⁸ This amount drastically underestimates the current price for water. Dollar amounts for water trades are not readily available to the public. However, information on the current price of water from news articles and other sources reveals a range of current prices that exceed \$225 by a significant amount.

A report by Bloomberg News on the impacts of drought on water prices reports water prices of \$1,000 to \$2,000 per af. The article also quotes a spokesman for the BOR,

“The rising prices are ‘a function of supply and demand in a very dry year and the fact that there are a lot of competing uses for water in California,’ said Mat Maucieri, a spokesman for the Bureau of Reclamation.”³⁹

An article in the Sacramento Bee on water transfers noted that one buyer was paying “in the neighborhood of \$500 to \$600 an acre-foot.”⁴⁰ The Glenn-Colusa Irrigation District commenting on the LTWT noted that the \$225 per af price used in the analysis was the price paid for water over eight years ago.⁴¹

Water users, sellers and buyers would surely respond differently to a market price of water of \$1,000 to \$2,000 per af, than they would to a price of \$225. As such, the extent to which growers idle cropland, switch to less water intensive crops, and substitute groundwater for surface water in the LTWT likely does not reflect this difference. As we note below, missing from the LTWT analysis is an assessment of the economics of water markets, how sellers and buyers respond to changing water prices, and how this affects the type and amount of water transfers.

27

³⁸ LTWT, page 3.10-27.

³⁹ Vekshin, A. 2014. “California Water Prices Soar for Farmers as Drought Grows,” Bloomberg. July 24. <http://www.bloomberg.com>.

⁴⁰ Garza, M. 2014. “The Conversation: A controversial water transfer worth millions.” The Sacramento Bee. May 25. <http://www.sacbee.com/opinion/the-conversation/article99570.html>.

⁴¹ Glenn-Colusa Irrigation District. 2014. *Board of Directors Meeting of November 6, 2014, Item 6*.

Ignored impacts on tax revenues to local governments from IMPLAN results

The LTWT describes estimating impacts of water transfers on employment, labor income and total value of output using IMPLAN.⁴² IMPLAN is a commonly used software and data package that helps analysts estimate economic impacts of policy changes or compare economic impacts of allocation alternatives, e.g., alternative logging proposals or alternative water-transfer amounts. According to the IMPLAN website, IMPLAN "... allows an analyst to trace spending through an economy and measure the cumulative effects of that spending."⁴³ IMPLAN traces the economic benefits of increased spending as it works its way through an economy, or, when spending decreases, the negative economic impacts of decreased spending. From our own experience using IMPLAN, and from information on the IMPLAN website, in addition to the employment, labor income and total value of output reported in the LTWT, IMPLAN also quantifies the impacts of alternatives on *government finances and tax revenues*.⁴⁴ For example, the IMPLAN website describes how the software can estimate state, local, and federal tax amounts collected (or lost) as a result of a change in an economy, such as reduced agricultural activity.⁴⁵

28

Even though IMPLAN calculates impacts of alternatives on local government finances and tax revenues, the analysis described in the LTWT does not report these results. That is, the authors apparently choose not to report the output from IMPLAN on how the transfer alternatives would affect the dollar amounts of tax revenues to local governments as a result of the reduced agricultural activity and spending. Instead, the report notes that impacts "to local government finances, including tax revenues and costs, are described *qualitatively*." [emphasis added]⁴⁶ The report does not explain why the analysts chose to address impacts on local tax revenues of the water-transfer alternatives qualitatively, rather than rely on the estimates of tax impacts produced by IMPLAN.

Ignored own research results on stream flow depletion factors

The LTWT makes no mention of the results from studies of the impacts of groundwater pumping in support of water transfers on stream flow depletion. A technical memo on the impacts of groundwater pumping on stream flow depletion describes the analysis and concludes that,

29

⁴² LTWT, page 3.10-21.

⁴³ IMPLAN web site, implan.com/index.php?option=com_glossary&id=236&letter=E.

⁴⁴ IMPLAN. https://implan.com/index.php?option=com_content&view=article&id=532:532&catid=233:KB16.

⁴⁵ IMPLAN. https://implan.com/index.php?option=com_content&view=article&id=532:532&catid=233:KB16.

⁴⁶ LTWT, page 3.10-24.

“The effect of groundwater substitution transfer pumping on stream flow, when considered as a percent of the groundwater pumped for the program, is significant.”⁴⁷

“The three scenarios presented here estimated effects of transfer pumping on stream flow when dry, normal, and wet conditions followed transfer pumping. Estimated stream flow losses in the five-year period following each scenario were 44, 39, and 19 percent of the amount of groundwater pumped during the four-month transfer period.”⁴⁸

In spite of these results, information distributed by the DWR and BOR to those interested in making water transfers in 2014, cites a stream flow depletion factor of 12 percent.⁴⁹ It’s not clear how BOR justifies using a 12-percent depletion factor when analyses conducted by their contractors found depletion factors of 44, 39 and 19 percent.

We understand that the same SACFEM model that produced other results in the LTWT also produced the stream flow depletion factors.⁵⁰ Yet, while the LTWT reports other results from SACFEM, it makes no mention of these results. It also ignores the assumed 12-percent depletion factor cited by DWR and BOR. Instead, it states that stream flow depletion will be studied at a later date.⁵¹ This approach ignores their own modeling results on stream flow depletion.

Incomplete and selective use of information from groundwater monitoring wells

The LTWT omits a significant concluding passage when describing results from a groundwater monitoring well in the Sacramento Valley.

For well 21N03W33A004M, the LTWT states,

“Water levels at well 21N03W33A004M generally declined during the 1970s and prior to import of surface water conveyed by the Tehama-Colusa Canal. During the 1980s, groundwater levels recovered due to import and use of surface water supply and because of the 1982 to 1984 wet water years [citation omitted].”⁵²

⁴⁷ Lawson, P. 2010. Technical Memorandum. Groundwater Substitution Transfer Impact Analysis, Sacramento Valley. CH2MHill. March 29. Page 8.

⁴⁸ Lawson, 2010, Page 8.

⁴⁹ DWR and BOR, 2014. Addendum to DRAFT Technical Information for Preparing Water Transfer Proposals. Information to Parties Interested in making Water Available for water Transfers in 2014. January. Page 33.

⁵⁰ LTWT, page 3.3-60.

⁵¹ LTWT, page 3.1-21.

⁵² LTWT, page 3.3-22.

29

30

The document cites a DWR report from 2014 on drought response and gaps in groundwater monitoring.⁵³ The description in the DWR report, however, includes this additional concluding passage that the LTWT authors excluded,

“Water levels declined again in the 2008 drought period, followed by a brief recovery during 2010 to 2011, and then returning to 2008 levels (which are notably lower than the 1977-79 drought levels).”⁵⁴ [emphasis added]

The omission matters as it completely changes the conclusion regarding current groundwater conditions as reported by the well.

The description in the LTWT of results from well 15N03W01N001M match those from the DWR source document. That description concludes,

“... After the 2008-2009 drought, water levels declined to historical lows. Water levels recovered quickly during 2010 and 2011, then after returned to the trend of long-term decline.”⁵⁵ [emphasis added]

Taken together these results indicate a long-term trend in declining groundwater levels in areas around the wells. The LTWT discounts or ignores these results instead favoring results from other wells. On this point, consulting hydrologist Custis describes other relevant data on groundwater monitoring,

“The Draft EIS/EIR doesn’t provide maps showing groundwater elevations, or depth to groundwater, for groundwater substitution transfer seller areas in Sutter, Yolo, Yuba, and Sacramento counties.

The DWR provides on a web site a number of additional groundwater level and depth to groundwater maps at: [website omitted].⁵⁶

Custis notes other deficiencies of the groundwater monitoring as described in the LTWT.

“...[T]he Draft EIS/EIR provides only limited information on the wells to be used in the groundwater substitution transfers [citation omitted], and no information on the non-participating wells that may be impacted.”⁵⁷

Custis goes on to list other recommended groundwater monitoring information that the LTWT does not include.⁵⁸

⁵³ LTWT, page 3.3-22.

⁵⁴ DWR, 2014a, page 24.

⁵⁵ LTWT, page 3.3-22.

⁵⁶ Custis 2014, pages 9-10.

⁵⁷ Custis 2014, page 2.

A related point is the available monitoring data from past water transfers. DWR and BOR apparently already collect information on the impacts of groundwater pumping in support of water transfers on groundwater levels.⁵⁹ The LTWT makes no mention of this data or how it could help inform the analysis of impacts of water transfers at issue in the LTWT on groundwater levels and related concerns. It would seem that BOR has available data relevant to its analysis described in the LTWT but makes no use of this data. On this point Custis notes,

31

“The BoR should already have monitoring and mitigation plans and evaluation reports based on the requirements of the DTIPWTP for past groundwater substitution transfers, which likely were undertaken by some of the same sellers as the proposed 10-year transfer project.”⁶⁰

The analysis relies on outdated prices for agricultural commodities

The analysis described in the LTWT uses outdated prices for agricultural commodities to estimate the volume and value of water transfers. The analysis relies on prices for rice, processing tomatoes, corn and alfalfa from 2006 through 2010.⁶¹ The analysis compares the price of water, which as we note above bears no resemblance to current prices, with prices for agricultural commodities to estimate cases in which selling water is more profitable than producing crops. Using outdated commodity prices compounds the error of using water prices that greatly underestimate actual prices. The combined effect is misleading results and conclusions regarding the degree of participation by growers in the water transfer program.

32

No mention of how prices for water and agricultural commodities could impact the affected environment, water transfers and their environmental and economic consequences

The water transfers at issue in the LTWT would not happen in an economic vacuum. Growers and water sellers and buyers react to changing price and market conditions. The LTWT, however, is silent on these forces and how they would influence water transfers.

33

The analysis depicted in the LTWT assumes a static water price of \$225 per af and prices for agricultural commodities as they existed in 2006 through 2010.⁶² Such a static analysis

⁵⁸ Custis 2014, page 2.

⁵⁹ See for example, DWR and BOR, 2014. *DRAFT Technical Information for Preparing Water Transfer Proposals. Information to Parties Interested in making Water Available for water Transfers in 2014*. January; DWR and BOR. 2013. *DRAFT Technical Information for Preparing Water Transfer Proposals. Information to Parties Interested in Making Water Available for Water Transfers in 2014*. October.

⁶⁰ Custis 2014, page 24.

⁶¹ LTWT, page 3.10-27, -28.

⁶² LTWT, page 3.10-27.

provides a single estimate, or a snapshot view, of estimated water transfers. A more informative and useful analysis would have described how changing water and commodity prices influence the conclusions re the number and volumes of water transfers. Such a sensitivity analysis would allow readers to better compare current or expected future prices with prices in the analysis to see how these conditions affect results.

33

The LTWT is also silent on likely transaction costs and how they influence water transfers. Water transactions, particularly out-of-basin and cross-Delta, would require a diverse and substantial set of transaction costs that are not quantitatively included in the analysis. Omitting these transaction costs either overestimates the benefit potential to buyers and sellers of these transactions, or implies that these transaction costs will be borne by the public. Communication, information, and contracting costs have long inhibited water markets in California, and while mechanisms for overcoming these challenges have improved, they do have real costs, particularly across diverse regions and incorporating farmers using differing operations.⁶³ Transaction costs are hurdles to transactions, functionally a third party that must be satisfied before the buyer and seller can find opportunities to both be made better off by the transaction. For example, if a seller is willing to sell water at \$250 per af, and a buyer is willing to pay \$300 per af, if there are \$60 per af in transaction costs, the transaction cannot efficiently take place.

34

Cross-Delta transaction would also impose a number of costs on the Delta conveyance system. Pumping costs at Banks and Jones Pumping Plants should be incorporated into transaction costs. Transactions could also affect congestion and overall capacity for these plants and the SWP and CVP systems overall. Energy, management, staffing, delays, and other costs and impositions could arise that would either require compensation by the buyers and sellers, or externalities on other parties.

Permitting, liability, and long-term protection of water rights all contribute to additional concerns for buyers and sellers that functionally generate additional forms of transaction costs. If these are incorporated into willingness-to-pay for buyers and willingness-to-accept for sellers, the transactions become less desirable. Alternatively, if these costs are borne by public agencies, as with the variety of other transaction costs mentioned above and referenced qualitatively throughout the LTWT, the burden for taxpayers could be substantial. These public contributions require demonstration of benefits to the public as a whole. The LTWT does not demonstrate benefits to portions of the public that are not party to transactions. On this point Custis notes,

“Because the spatial limits of groundwater substitution pumping impacts are controlled by hydrogeology, hydrology, and rates, durations and seasons of pumping, the impacts may not be limited to the boundaries of each seller’s service area, GMPs [groundwater

⁶³ Haddad, B. M. 2000. *Rivers of Gold: Designing Markets to Allocate Water in California*. Island Press.

management plan], or County. There is a possibility that a seller's groundwater substitution area of impact will occur in multiple local jurisdictions, which should results [sic] in project requirements coming from multiple local as well as state and federal agencies. The Draft EIS/EIR doesn't discuss which of the multiple local agencies would be the lead agency, how an agreement between agencies would be reached, or how the requirements of the other agencies will be enforced."⁶⁴

34

Overall, the estimates of benefits and costs of transactions, as well as identification of efficient transactions, do not include the diverse and substantial set of transaction costs that cross-Delta transfers would require. Therefore the analysis either overestimates the benefits of the LTWT, or hides public costs to manage and overcome these transaction costs.

⁶⁴ Custis 2014, page 9.

4 The LTWT underestimates negative impacts on the regional economy in the sellers area

In this section we describe our comments on the analysis of regional economic effects in the LTWT.

Underestimates economic effects on regional economy in sellers area

In the sections above, we describe omissions and errors regarding the estimated number and volumes of water transfers. Some of these errors could lead to underestimating the number and volume of water transfers, some could have the opposite effect. In this subsection we focus on additional examples of how the LTWT likely underestimates the number and volume of water transfers that will happen in the future. By underestimating the water transfers the LTWT also underestimates the negative impacts of the transfers on the regional economy in the sellers area.

The negative economic effects listed in the LTWT include:

- Approximately 500 lost jobs in Glenn, Colusa, Yolo, Sutter, Butte and Solano counties.
- Over \$20 million in lost labor income and over \$61 million in lost economic output in these same counties.
- Unquantified but increased pumping costs for water users in areas where groundwater levels decline.
- Unquantified but negative affects on other local economic effects.
- Unquantified but negative affects on tenant farmers.⁶⁵

The LTWT analysis of some regional economic effects assumes non-consecutive years of water transfers. If water transfers happen in consecutive years, impacts would be greater than reported in the LTWT.

“Local effects would be more adverse if cropland idling transfers occurred in consecutive years. Business owners would likely be able to recover from reduced sales in a single year, but it would be more difficult if sales remained low for multiple years.”⁶⁶

As shown in LTWT Table 1-3 on page 1-17, from 2004 through 2014, there have been eight water-transfer years out of 11, and 5 cases of consecutive transfer years. Given these recent

⁶⁵ LTWT, page 3.10-45 and -46.

⁶⁶ LTWT, page 3.10-33.

conditions, it is likely that consecutive years of water transfers will happen more frequently than assumed in the LTWT.

35

Incomplete description of impacts on pumping costs

The LTWT reports that farmers in the Sacramento and San Joaquin Valleys pay water-pumping costs of approximately \$0.32 per af.⁶⁷ The LTWT analysis estimates that as a result of groundwater-substitution transfers, pumping costs for “many growers” would increase by \$0.32 to \$1.60 per af.⁶⁸ This represents a non-trivial increase of 100 to 500 percent. In some cases, cost increases could be \$6.40 to \$8.00 per af.⁶⁹ Expressed on a percentage basis these amounts are increases of 2,000 to 2,500 percent. The LTWT describes these increases in pumping costs as “adverse.” The analysis, however, does not report a total estimated increase in pumping costs or describe the increase as a percentage of current costs, either of which would have helped the reader better understand the significance of the increase.⁷⁰ A related point is that the analysis of pumping costs in the LTWT relies on results from the water modeling, the deficiencies of which we describe above and elsewhere in this report.

36

It’s also not clear from the description of the analysis if the “adverse” effects on pumping costs apply only to those participating in water transfers, or also affect third parties that will not benefit from the transfers.

No mention of costs of deepening or installing new wells

The LTWT makes no mention of increased costs of deepening or installing new wells as a result of the impacts of groundwater pumping on groundwater levels. As we note above in section 2 under the description of current groundwater conditions, the CASGEM groundwater basin prioritization study lists 23 basins in the Sacramento Valley ranked “high” or “medium” dependent on groundwater. These basins support private residential wells, public water supply wells, and irrigation wells.⁷¹ Recent news reports describe the intensity of well drilling operations in California’s Central Valley.⁷² To the extent that groundwater pumping in support of water transfers lowers groundwater levels, some

37

⁶⁷ LTWT, page 3.10-24.

⁶⁸ LTWT, page 3.10-36.

⁶⁹ LTWT, page 3.10-36.

⁷⁰ A related point is that Figures 3.10-5 and 3.10-6 are confusing in that the captions include “September 1990” and “September 1976,” respectively. The discussion on page 3.10-36, which introduces the figures, makes no mention of these dates or their significance.

⁷¹ DWR, 2014b, pages 2-5.

⁷² Howard, B.C. 2014. California drought spurs groundwater drilling boom in Central Valley. National Geographic. August 15. <http://news.nationalgeographic.com/news.2014/08/140815-central-valley-california-drilling-boom-groundwater-drought-wells/>; Khokha, S. 2014. Drought has drillers running after shrinking California water supply. National Public Radio. June 30. <http://www.npr.org/2014/06/30/325494399/drought-has-drillers-running-after-shrinking-california-water-supply>.

current water users depending on groundwater may face increased costs of deepening or installing new wells. The analysis described in the LTWT does not address these costs.

37

Underestimates the significance of impacts on unemployment rates

Any negative impacts of water transfers on agricultural production and related unemployment effects, would take place against a backdrop of already hurting economies. As Figure 3.10-7 illustrates, current unemployment rates in the seller counties runs between approximately 8 and 18 percent. The LTWT analysis estimates that water transfers will idle approximately 500 workers in the Sacramento Valley. The analysis assumes that impacts of transfers on unemployment would be temporary.

38

“Reductions in employment associated with cropland idling transfers would contribute to unemployment in the region. However, cropland idling effects are temporary and under the Proposed Action, cropland idling transfers would not occur each year over the 10-year period.”⁷³

As we note above, however, data on the frequency of recent water transfers do not support the LTWT assumptions regarding infrequent future water-transfer years. Thus, the LTWT analysis likely underestimated the negative impacts of the plan on unemployment in the Sacramento Valley.

No mention of economic harm to local economies from lost water-based recreational activities

The analysis of regional economic effects in the LTWT focuses on impacts of water transfers on agricultural production and related businesses. The LTWT ignores other negative impacts on the regional economy. For example, the LTWT is silent on the impacts of water transfers on reservoirs such as Lake Oroville and others in the sellers area, and the related impacts on the region’s water-based recreational economy. In their letter commenting on the LTWT, the Butte County Board of Supervisors noted their concerns that the LTWT “... failed to take into account the reduction in stream flows and the lowering of Lake Oroville that will harm the local economy.”⁷⁴ In an earlier letter to Governor Brown commenting on the BDCP, the Butte County Board of Supervisors noted the importance of the lake to the region’s economy, and the fact that the State of California has not fulfilled commitments made regarding developments at Lake Oroville.⁷⁵ Ignoring the potential impacts of water transfers on Lake Oroville and the associated economic impacts compounds the negative effects of the State’s failure to fulfill past commitments at the lake.

39

⁷³ LTWT, page 3.10-49.

⁷⁴ Teeter, D. 2014. *Letter to Brad Hubbard, BOR, and Frances Mizuno, SLDMWA*, November 25. Re: Long-Term Water transfers Program Draft Environmental Impact Statement/Environmental Impact Report (EIS/EIR). Page 2.

⁷⁵ Lambert, S. 2012. *Letter to The Honorable Edmund G. Brrown, Jr.* August 14. Re: Butte County’s Opposition to the Bay Delta Conservation Plan (BDCP). August 14. Page 2.

Arbitrary limits on crop idling

The analysis in the LTWT relies on arbitrary limits on crop idling as a means of avoiding negative economic impacts. The DWR and BOR document that provides technical guidance for those interested in making water transfers describes the possibility of negative economic effects of crop idling, however, the guidelines for the amount of idling that would cause economic harm appear arbitrary. The relevant passage from the document states,

“Cropland idling/crop shifting transfers have the potential to affect the local economy. Parties that depend on farming-related activities can experience decreases in business if land idling becomes extensive. Limiting cropland idling to 20 percent of the total irrigable land in a county *should* limit economic effects.”⁷⁶ [emphasis added]

While the statement may be true, it lacks the analytical rigor that would satisfy NEPA requirements for, “Rigorous exploration and objective evaluation of all reasonable alternatives, ...”⁷⁷ As such, the guidelines on crop idling seem arbitrary rather than the result of rigorous and objective analysis.

Table 3.10-22 lists the total number of acres affected by cropland idling in the analysis described in the LTWT. As shown in this table, approximately 60,000 acres could be idled in Glenn, Colusa, Yolo, Sutter, and Butte counties.⁷⁸ In the table below, we show the total number of acres of irrigable land in each county, and 20 percent of these acres. According to the guidelines noted above, up to 257,000 acres could be idled in these counties without significant economic effects. This seems doubtful. Rather than relying on arbitrary rules of thumb and assumed limited economic effects of idling, a more complete and transparent assessment of the economic effects of water transfers would take an analytical and quantified approach.

Table 1: Acres of Cropland, by County, 2011.

County	Acres of Cropland	20 Percent of Acres
Butte	224,592	47,969
Colusa	291,435	56,246
Glenn	250,493	50,099
Sutter	239,846	58,287
Yolo	281,228	44,918
Total	1,287,594	257,519

Source: US Department of Agriculture. 2011. California Cropland Data Layer. National Agricultural Statistics Service. Research and Development Division, Geospatial Information Branch, Spatial Analysis Research Section.

⁷⁶ DWR and BOR, 2013. *DRAFT Technical Information for Preparing Water Transfer Proposals. Information to Parties Interested in Making Water Available for Water Transfers in 2014*. October. Page 22.

⁷⁷ LTWT page 2-1.

⁷⁸ LTWT, page 3.10-26.

40

41

5 The LTWT finds significant negative effects but the vague and incomplete proposed monitoring and mitigation plans would not address these effects

The LTWT concludes that water transfers will have some significantly negative impacts on groundwater resources. As we note in earlier sections of this report, the analysis described in the LTWT likely underestimates the negative effects of water transfers. For example, the analysis likely underestimates the frequency of water-transfer years, and so the negative effects of the transfers. The analysis also ignores negative impacts on water-based recreational activities and the associated negative economic consequences. The monitoring and mitigation plans focus only on the negative effects listed in the LTWT. Thus, they would address only a subset of the likely total negative economic consequences of the water transfers. In addition, the vague and incomplete proposed monitoring and mitigation plans would not adequately address those negative effects listed in the LTWT. Concerns regarding these plans include the following.

42

The LTWT ignored the costs of monitoring and mitigation

The LTWT proposes both a monitoring and mitigation program for significant negative impacts of water transfers on groundwater resources. Implementing these programs would take planning, effort and financial resources. The LTWT, however, does not include these costs in their analysis of alternatives. For example, water sellers would be required to monitor and record groundwater conditions and coordinate with regulators regarding the impacts of their groundwater pumping on groundwater levels. Water seller will incur costs monitoring, measuring, recording, and reporting the necessary information. The LTWT excludes these and related costs from the analysis.

43

Likewise, the mitigation of negative groundwater consequences would also require time, effort, and costs to water sellers, third parties negatively affected by groundwater pumping, and regulators. LTWT excludes these costs as well.

The monitoring and mitigation programs include inherent conflicts of interests

The monitoring program as described in the LTWT is vague and depends on sellers implementing the program. This conflict of interest pits financial gain from water sales against complete and impartial monitoring efforts. This opens the door to lax, biased, or incomplete monitoring, which could lead to negative environmental and economic consequences for third parties not part of the water transfers.

44

The monitoring program includes provisions for a coordination plan that would share information among “well operators and other decision makers.”⁷⁹ Such confidential results would keep other stakeholders in the dark regarding the impacts of water transfers. Given the fact that multiple wells belonging to multiple property owners can access the same groundwater aquifer, and that groundwater pumping can affect flows of surface water, such a confidential program seems counter to the wellbeing of the regional economy in the sellers area. An open monitoring program with public results would better communicate the potential environmental and economic risks of groundwater pumping in support of water transfers.

44

If the seller’s monitoring program finds that water sales are causing “substantial adverse impacts”⁸⁰ the seller will be responsible for implementing a mitigation program. The conflict of interest is obvious.

One method of avoiding the obvious conflicts of interests is requiring monitoring by independent third parties not involved with or affected by groundwater pumping in support of water transfers. Such monitoring could be detailed, transparent and public, which would alleviate concerns over the risks and consequences of negative environmental and economic effects of groundwater pumping. Mitigation decisions and requirements should likewise be detailed, transparent and public for the same reasons.

Insufficient monitoring period

As described in the LTWT, groundwater levels would be monitored through March of the year following a transfer. It’s not clear that this limited monitoring period is sufficiently long enough to track potential impacts on groundwater of water transfers. For example, the report cited above for the NCWA states,

“...[G]roundwater changes can take many years to become apparent, and we have not yet been able to measure with certainty the long-term impacts of the current level of groundwater use as it affects our measures of sustainability.”⁸¹

45

An insufficient monitoring period could underestimate the impacts of groundwater pumping on groundwater levels and impacts on stream flow depletions. Lowering groundwater level and increasing stream flow depletions would generate negative environmental and economic impacts. The monitoring period in the LTWT may cause analysts to underestimate the environmental and economic effects of the water-transfers alternatives.

⁷⁹ LTWT, page 3.3-89.

⁸⁰ LTWT, page 3.3-90.

⁸¹ DMW, 2014, page 10.

Insufficient monitoring for land subsidence

The monitoring program includes monitoring subsidence, however, the program is vague on monitoring requirements and what amount of subsidence would trigger a halt in water transfers. Custis describes a number of technical deficiencies in the proposed mitigation plan.

“The Draft EIS/EIR should be able to provide the specific thresholds of subsidence that will trigger the need for additional extensometer monitoring, continuous GPS monitoring, or extensive land-elevation benchmark surveys by a licensed surveyor as required by GW-1. The Draft EIS/EIR should also specify in mitigation measure GW-1, the frequency and methods of collecting and reporting subsidence measurements, and discuss how the non-participating landowners and the public can obtain this information in a timely manner. In addition, the Draft EIS/EIR should provide a discussion of the thresholds that will trigger implementation of the reimbursement mitigation measure required by GW-1 for repair or modifications to infrastructure damaged by non-reversible subsidence, and the procedures for seeking monetary recovery from subsidence damage [citation omitted].”

46

“Specific ‘strategic’ subsidence monitoring locations should be given in mitigation measure GW-1 based on analysis of the susceptible infrastructure locations and the potential subsidence areas.”⁸²

Implementing the Custis recommendations will take time and financial resources for water sellers, local jurisdictions and third parties negatively affected by groundwater pumping. The LTWT does not include the costs of these measures in the analysis. Thus, the costs of the water transfers described in the LTWT underestimate the true costs of the program.

Vague significance criteria

The mitigation program includes a number of vague descriptions of critical components. Relevant missing descriptions include details on:

- How regulators and stakeholders would define “substantial adverse impacts” from groundwater pumping.
- What constitutes a “significant” increase in pumping costs suffered by injured third parties.
- Required modifications to damaged third-party infrastructure or the installation of new infrastructure.

47

⁸² Custis 2014, page 28.

- The procedure that injured third parties would use when making claims against a seller.
- The procedure that regulators and stakeholders would use when investigating third-party claims.
- What constitutes “legitimate significant effects” on third parties.⁸³

A vague and ill-defined mitigation program increases risks of environmental and economic harm, and shifts the costs of such harm from water sellers to third parties and society in general. The analysis described in the LTWT does not identify, describe or quantify these risks, costs and consequences. A related point is that the LTWT makes no mention of BOR addressing these or similar issues as part of reviewing past annual water transfers. Including such information from past water transfers—if BOR considered these effects—in the LTWT could help illustrate or describe the uncertainties listed above.

47

The mitigation plan puts costs on to injured third parties

Injured third parties bear the costs of bringing to the sellers’ attention harm caused by groundwater pumping. Also, the LTWT states that proposed mitigation options would be developed “in cooperation”⁸⁴ with injured third parties. This approach places costs on injured third parties rather than on sellers. That is, those who would not benefit financially from the program bear the costs of bringing negative impacts to the sellers’ attention. They also would incur costs of documenting and presenting their damages in the context of an ill-defined mitigation program. This raises equity concerns that those suffering costs of the program bear the additional costs of identifying, describing and calling attention to their costs. The analysis described in the LTWT further assumes that disagreements regarding third-party damages would be settled cooperatively, without presenting evidence substantiating such an optimistic assumption. The LTWT is silent on the economic consequences of sellers and injured third parties not cooperatively agreeing on harm and compensation.

48

As we note above, information the BOR collected from past water transfers may help inform the types and amounts of costs that injured third parties could incur as a result of the water transfers at issue in the LTWT.

BOR’s role in monitoring and mitigation

The LTWT describes a substantive role for BOR in the monitoring and mitigation program, without specifics of how BOR would implement its responsibilities. Topic not addressed include:

49

⁸³ LTWT, page 3.3-88 through -91.

⁸⁴ LTWT, page 3.3-91.

- The costs to BOR of monitoring and mitigation.
- The details of interactions between sellers, injured third parties, and BOR staff regarding the details of monitoring and mitigation.
- The details of collecting, organizing and publishing relevant details of monitoring and mitigation.
- The details of decision making processes that affect monitoring and mitigation.
- The details of interactions between BOR and other federal or state agencies, and BOR and local jurisdictions.

49

Lead CEQA agency

SLDMWA is the lead state agency regarding CEQA compliance. It is also one of three potential buyers for the transferred water.⁸⁵ This arrangement creates a conflict of interest in that the lead CEQA agency also has a self interest in facilitating the water transfers. As described on their website, SLDMWA delivers approximately 3 million af of water to member agencies.⁸⁶ SLDMWA has a financial and operational interest in delivering water to its members. Thus, SLDMWA is not an impartial agent.

50

The LTWT provides no information on why SLDMWA is the lead state agency and not the California Department of Water Resources.

⁸⁵ LTWT EIS/EIR, Table 1-2, page 1-5. The other two buyers are Contra Costa Water District and the East Bay Municipal Utility District.

⁸⁶ SLDMWA web site, www.sldmwa.org/learn-more/about-us/.

6 The LTWT ignores the economic costs of environmental externalities and subsidies that water transfers support

51

The LTWT lists Westlands Water District as one of the CVP contractors expressing interest in purchasing transfer water.⁸⁷ The environmental externalities caused by agricultural production in Westlands are well documented, as are the economic subsidies that support this production. To the extent that the water transfers at issue in the LTWT facilitate agricultural production in Westlands, they also contribute to the environmental externalities and economic subsidies of that production. The LTWT is silent on these environmental and economic consequences of the water transfers.

In this section we summarize recent information on the environmental externalities and economic subsidies of agricultural production on Westlands that water transfers would support.

The environmental and economic externalities of Westlands have a long history

52

For decades, high levels of selenium have posed a serious environmental threat to drinking water, soil quality, and agriculture in the Westlands Water District.⁸⁸ This naturally occurring element leaches into soil and drinking water when irrigation water is applied and when significant levels accumulate, has been known to cause deformities and death in wildlife and human beings.⁸⁹ The most extreme example of this type of degradation occurred from 1981-1986 during the Kesterson Disaster, when the federally operated San Luis Unit diverted selenium-rich wastewater into the Kesterson National Wildlife Refuge, killing over one thousand birds and causing severe birth defects.⁹⁰

⁸⁷ LTWT, page 1-5.

⁸⁸ Environmental Working Group. 2010a, September 28. Throwing Good Money at Bad Land. *Environmental Working Group*. Retrieved from <http://www.ewg.org/Throwing-Good-Money-at-Bad-Land>

⁸⁹ Environmental Working Group. 2010a, September 28. Throwing Good Money at Bad Land. *Environmental Working Group*. Retrieved from <http://www.ewg.org/Throwing-Good-Money-at-Bad-Land>

⁹⁰ Environmental Working Group. 2010a, September 28. Throwing Good Money at Bad Land. *Environmental Working Group*. Retrieved from <http://www.ewg.org/Throwing-Good-Money-at-Bad-Land>; Environmental Working Group. 2010b, September 28. U.S. Taxpayers Paid nearly \$60 million to Farmers on Westlands Toxic Lands. *Environmental Working Group*. Retrieved from <http://www.ewg.org/Throwing-Good-Money-at-Bad-Land>; Luoma, Samuel N. and Teresa S. Presser. (2000). Forecasting Selenium Discharges to the San Francisco Bay-Delta Estuary: Ecological Effects of a Proposed San Luis Drain Extension. U.S. Geological Survey. (Open-File Report 00-416). Menlo Park, California.

Current environmental concerns

Since the Kesterson Disaster, the Westlands has followed a “no-discharge policy” where irrigated wastewater is reused on agricultural land or stored in groundwater aquifers.⁹¹ In spite of the well-documented concerns regarding selenium contaminated runoff from Westlands, as yet there is no official monitoring of selenium levels in the district.⁹² The San Luis Act (1960) gives the BOR, not the Westlands Water District, responsibility for disposing of Westland Water,⁹³ but as of yet neither entity has implemented any meaningful solution. This failure prompted the Westlands District to bring a lawsuit against the BOR in 1995, which was finally brought to the Ninth Circuit Court of Appeals in 2000.⁹⁴ The court upheld a lower court’s decision to force the BOR to provide drainage to the district but allowed that solutions other than a drain might be considered.⁹⁵

At first, it seemed that large-scale retirement of farmland was the solution favored by both the Westlands and the federal government.⁹⁶ In 2001, the District released a fact sheet entitled “Why Land Retirement Makes Sense for the Westlands Water District” advocating for a possible deal with the federal government that would retire up to 200,000 acres of agricultural land. According to the federal government’s National Economic Development analysis, this option would result in an economic gain of \$3.6 million per year excluding any additional savings as a result of reduced crop subsidies.⁹⁷ Instead, after more than a decade of negotiations, the federal

⁹¹ State of California. Central Valley Regional Water Quality Control Board. Irrigated Lands Program – Development of the Long-term Program.

http://www.waterboards.ca.gov/centralvalley/water_issues/irrigated_lands/new_waste_discharge_requirements/western_tulare_lake_basin_area_wdrs/index.shtml#octdec2013

⁹² State of California. Central Valley Regional Water Quality Control Board. Irrigated Lands Program – Development of the Long-term Program.

http://www.waterboards.ca.gov/centralvalley/water_issues/irrigated_lands/new_waste_discharge_requirements/western_tulare_lake_basin_area_wdrs/index.shtml#octdec2013

⁹³ US Bureau of Reclamation. 2012a, August 7. *CVP Ratebooks - Irrigation, 2012*. Retrieved from <http://www.usbr.gov/mp/cvpwaterrates/ratebooks/irrigation/2012/index.html>; U.S. Bureau of Reclamation. 2012b, September. San Luis Unit Drainage, Central Valley Project. *Reclamation: Managing Water in the West*. Retrieved from http://www.usbr.gov/mp/PA/docs/fact_sheets/San_Luis_Drainage.pdf.

⁹⁴ US Bureau of Reclamation. 2012a, August 7. *CVP Ratebooks - Irrigation, 2012*. Retrieved from <http://www.usbr.gov/mp/cvpwaterrates/ratebooks/irrigation/2012/index.html>; U.S. Bureau of Reclamation. 2012b, September. San Luis Unit Drainage, Central Valley Project. *Reclamation: Managing Water in the West*. Retrieved from http://www.usbr.gov/mp/PA/docs/fact_sheets/San_Luis_Drainage.pdf.

⁹⁵ US Bureau of Reclamation. 2012a, August 7. *CVP Ratebooks - Irrigation, 2012*. Retrieved from <http://www.usbr.gov/mp/cvpwaterrates/ratebooks/irrigation/2012/index.html>; U.S. Bureau of Reclamation. 2012b, September. San Luis Unit Drainage, Central Valley Project. *Reclamation: Managing Water in the West*. Retrieved from http://www.usbr.gov/mp/PA/docs/fact_sheets/San_Luis_Drainage.pdf.

⁹⁶ Westlands Water District. 2001, October 16. Why Land Retirement Makes Sense for Westlands Water District. *Westlands Water District*.

⁹⁷ Westlands Water District. 2001, October 16. Why Land Retirement Makes Sense for Westlands Water District. *Westlands Water District*; Sharp, Renée. 2010, September 28. Throwing Good Money at Bad Land. *Environmental Working Group*. Retrieved from <http://www.ewg.org/agmag/2010/10/throwing-good-money-after-bad-lands>.

government and the Westlands Water District finally signed an agreement in 2014 which lifts the federal government's obligation to provide drainage to the district, forgives the nearly \$400 million the district owes to the federal government for its part in the construction of the Central Valley Project (CVP), assures the district almost 900,000 acre-feet of water per year from the CVP, and requires only 100,000 acres of land be retired.⁹⁸ This leaves over 100,000 more acres of selenium-degraded land that the Westlands Water District will now need to decide how to drain in the years to come.⁹⁹ In addition, while the BOR's Environmental Assessment found that there would be no significant environmental impact as a result of the interim renewal contracts with the Westlands and other CVP districts, several environmental groups have criticized the study as violating federal environmental requirements, including the National Environmental Policy Act of 1969.¹⁰⁰

53

Economic subsidies to the Westlands water district

As the largest water district in California and the largest recipient of water under the Central Valley Project, the Westlands Water District receives significant crop, water, and power subsidies to supplement its agricultural activities. According to a report by the Environmental Working Group, between 2005 and 2009, the federal government issued almost \$55 million of counter cyclical and direct crop subsidies to 356 individuals in the district.¹⁰¹ The district's 350 farms networks are entitled to over 1.1 million acre-feet of water per year, more than twice the allocation of the City of Los Angeles.¹⁰² In 2002, the group estimated that the federal

54

⁹⁸ California Water Impact Network. 2014, October 16. Obama Selling Out California to Westlands Water District. *California Water Impact Network*. Retrieved from <http://www.c-win.org/content/media-release-obama-selling-out-california-westlands-water-district-secret-deal-forgives-gov>; US Department of the Interior. 2013, December 6. *PRINCIPLES OF AGREEMENT FOR A PROPOSED SETTLEMENT BETWEEN THE UNITED STATES AND WESTLANDS WATER DISTRICT REGARDING DRAINAGE*. Retrieved from www.c-win.org/webfm_send/453; Boxall, Bettina. 2014, October 21. Amid California's drought, a bruising battle for cheap water. *Los Angeles Times*. Retrieved from <http://www.latimes.com/local/california/la-me-westlands-20141021-story.html#page=2>.

⁹⁹ Environmental Working Group. 2010a, September 28. Throwing Good Money at Bad Land. *Environmental Working Group*. Retrieved from <http://www.ewg.org/Throwing-Good-Money-at-Bad-Land>.

¹⁰⁰ US Bureau of Reclamation. 2013, December 7. *Central Valley Interim Renewal Contracts for Westlands Water District, Santa Clara Valley Water District, and Pajaro Valley Water Management Agency 2014-2016*. (FONSI-13-023). Sacramento, CA; Minton, Jonas, Kathryn Phillips, et al. 2014, January 14. The Environmental Assessment [EA] for Westlands Water District et. al. Central Valley Project Interim 6 Contract Renewals for Approximately 1.2 MAF of water [Letter to Rain Emerson, Bureau of Reclamation].

¹⁰¹ Environmental Working Group. 2010a, September 28. Throwing Good Money at Bad Land. *Environmental Working Group*. Retrieved from <http://www.ewg.org/Throwing-Good-Money-at-Bad-Land>; Environmental Working Group. 2010b, September 28. U.S. Taxpayers Paid nearly \$60 million to Farmers on Westlands Toxic Lands. *Environmental Working Group*. Retrieved from <http://www.ewg.org/Throwing-Good-Money-at-Bad-Land>.

¹⁰² Boxall, Bettina. 2014, October 21. Amid California's drought, a bruising battle for cheap water. *Los Angeles Times*. Retrieved from <http://www.latimes.com/local/california/la-me-westlands-20141021-story.html#page=2>; Environmental Working Group. 2005, September 14. Soaking Uncle Sam: Why Westlands Water District's New Contract is All Wet. *Environmental Working Group*. Retrieved from <http://www.ewg.org/research/soaking-uncle-sam>.

government paid \$110 million per year in water subsidies, making its water drastically less expensive than that allocated to urban households.¹⁰³

In 2002, the Westlands Water District received more than \$70 million in power subsidies. Although the Westlands receives 25% of all water from the CVP, it consumes 60% of the electricity required to deliver water to all districts and 60% of all government granted power subsidies to the CVP.¹⁰⁴

As mentioned above, the federal government has subsidized the Central Valley Project since its construction. While farmers were meant to pay \$1 billion of the \$3.6 billion project cost fifty years after its completion, it's estimated that by 2008, only 20% of that debt had been repaid.¹⁰⁵

54

¹⁰³ Boxall, Bettina. 2014, October 21. Amid California's drought, a bruising battle for cheap water. *Los Angeles Times*. Retrieved from <http://www.latimes.com/local/california/la-me-westlands-20141021-story.html#page=2>; Environmental Working Group. 2005, September 14. Soaking Uncle Sam: Why Westlands Water District's New Contract is All Wet. *Environmental Working Group*. Retrieved from <http://www.ewg.org/research/soaking-uncle-sam>; Environmental Working Group. 2007, May 30. Power Drain: The Biggest Winner: Westlands. *Environmental Working Group*. Retrieved from <http://www.ewg.org/research/power-drain/biggest-winner-westlands>.

¹⁰⁴ Environmental Working Group. 2007, May 30. Power Drain: The Biggest Winner: Westlands. *Environmental Working Group*. Retrieved from <http://www.ewg.org/research/power-drain/biggest-winner-westlands>.

¹⁰⁵ Environmental Working Group. 2010a, September 28. Throwing Good Money at Bad Land. *Environmental Working Group*. Retrieved from <http://www.ewg.org/Throwing-Good-Money-at-Bad-Land>.

7 The LTWT underestimates the cumulative effects of water transfers

Cumulative effects analyses under NEPA and CEQA are intended to identify impacts that materialize or are compounded when the proposed action is implemented at the same time as or in conjunction with other actions. In Chapters 3 and 4, the LTWT addresses cumulative effects for each resource area and provides a global description of the methods and actions considered for analysis in each resource area. Section 3.10 provides a cursory discussion of potential cumulative effects for the regional economy, but ignores the full range of possible cumulative outcomes associated with the proposed action.

According to NEPA and CEQA requirements, cumulative effects analysis must examine the possibility of effects occurring across several dimensions. When multiple projects produce effects within the same geographic and temporal range, they may:

- Expand or contract the set of possible impacts.
- Increase or decrease the likelihood of specific potential impacts.
- Accelerate or decelerate the timing of specific potential impacts.
- Change the trajectory of potential impacts.
- Increase or decrease the economic importance of specific potential impacts.
- Shift the distribution of uncertainty or risk borne by different groups.

Cumulative effects may arise as multiple projects interact in a linear fashion, resulting in impacts that are additive. Interactions might also be non-linear, either offsetting each other to be less than additive, or exacerbating each other to be greater than additive.

The LTWT does not adequately consider cumulative effects within this framework, so misses important interactions that could result in significant impacts beyond those identified for the project alone.

One of the greatest potential sources of cumulative impacts is non-CVP water transfers. Although transfers under the SWP were considered, the possibility of other transfers occurring was not. Additional transfers would have similar impacts in the sellers' region, and may also lead to net effects that exceed sustainable thresholds and have a larger impact than each would individually. For example, the analysis

- Ignores cumulative effects of additional water transfers on water prices, and fails to examine the effects of price on the decisions and behaviors of farmers in the context of other water transfers.
- Ignores effects resulting from additional water transfers that have the potential to influence agricultural prices, and how those agricultural prices influence decisions about water transfers.

- Treats effects as “temporary” and thus not significant, and thereby fails to adequately account for potential thresholds in the local agricultural economy where short-term effects would become long-term effects.
- Assumes mitigation for groundwater effects of the proposed action would make farmers whole, so fails to properly account for potential threshold effects in groundwater resources, and associated costs to farmers.
- Ignores the possibility that increased uncertainty related to groundwater levels, agricultural market conditions, etc. from the proposed action, in conjunction with other actions, would adversely affect farmers.
- Ignores the cumulative effects of additional water transfers on environmental resources and conditions including aquatic, riparian, terrestrial and avian species and habitats.

55

AQUALLIANCE

DEFENDING NORTHERN CALIFORNIA WATERS



December 1, 2014

Mr. Brad Hubbard
 United States Bureau of Reclamation
 2800 Cottage Way, MP-410
 Sacramento, CA 95825
bhubbard@usbr.gov

Ms. Frances Mizuno
 San Luis & Delta Mendota Water Authority
 842 6th Street
 Los Banos, CA 93635
frances.mizuno@sldmwa.org

Subject: Comments on the *Draft Environmental Impact Statement/Environmental Impact Report Long Term North-to-South 2015-2024 Water Transfer Program*

Dear Mr. Hubbard and Ms. Mizuno:

AquAlliance, California Sportfishing Protection Alliance (“CSPA”), and Aqua Terra Aeris submit the following comments and questions for the Bureau of Reclamation (“Bureau”) and the San Luis Delta Mendota Water Authority’s (“SLDMWA”) (“Lead Agencies”) *Draft Environmental Impact Statement (“EIS”)* and *Environmental Impact Report (“EIR”)* (“EIS/EIR”), for the 2015-2024 *Long Term North-to-South Water Transfer Program* (“Project” or “2015-2024 Water Transfer Program”).

AquAlliance exists to sustain and defend northern California waters. We have participated in past water transfer processes, commented on past transfer documents, and sued the Bureau twice in the last five years. In doing so we seek to protect the Sacramento River’s watershed in order to sustain family farms and communities, enhance Delta water quality, protect creeks and rivers, native flora and fauna, vernal pools and recreational opportunities, and to participate in planning locally and regionally for the watershed’s long-term future. The *2015-2024 Water Transfer Program* is seriously deficient and should be withdrawn. If the Bureau and DWR are determined to pursue water transfers from the Sacramento Valley, AquAlliance requests that the agencies regroup and prepare an adequate programmatic EIS/EIR.

This letter relies significantly on, references, and incorporates by reference as though fully stated herein, for which we expressly request that a response to each comment contained therein be provided, the following comments submitted on behalf of AquAlliance:

1

- Custis, Kit H., 2014. Comments and recommendations on U.S. Bureau of Reclamation and San Luis & Delta-Mendota Water Authority Draft Long-Term Water Transfer DRAFT EIS/EIR, Prepared for AquAlliance. (“Custis,” Exhibit A)
- ECONorthwest, 2014. Critique of Long-Term Water Transfers Environmental Impact Statement/Environmental Impact Report Public Draft, Prepared for AquAlliance. (“EcoNorthwest,” Exhibit B)
- Mish, Kyran D., 2014. Comments for AquAlliance on Long-Term Water Transfers Draft EIR/EIS. (“Mish,” Exhibit C)
- Cannon, Tom, Comments on Long Term Transfers EIR/EIS, Review of Effects on Special Status Fish. Prepared for California Sportfishing Protection Association. (“Cannon,” Exhibit D)

1

In addition, we renew the following comments previously submitted, attached hereto, as fully bearing upon the presently proposed project and request:

- 2009 Drought Water Bank (“DWB”). (Exhibit F)
- 2010-2011 Water Transfer Program. (Exhibit G)
- 2013 Water Transfer Program. (Exhibit G)
- 2014 Water Transfer Program. (Exhibit G)
- C-WIN, CSPA, AquAlliance Comments and Attachments for the Bay Delta Conservation Plan’s EIS/EIR. (Exhibit H)
- AquAlliance’s comments on the Bay Delta Conservation Plan’s EIS/EIR. (Exhibit H)
- CSPA’s comments on the Bay Delta Conservation Plan’s EIS/EIR. (Exhibit H)

I. The EIS/EIR Contains an Inadequate Project Description.

A “finite project description is indispensable to an informative, legally adequate EIR.” *County of Inyo v. City of Los Angeles* (1977) 71 Cal.App.3d 185, 192. CEQA defines a “project” to include “the whole of an action” that may result in adverse environmental change. CEQA Guidelines § 15378. A project may not be split into component parts each subject to separate environmental review. *See, e.g., Orinda Ass’n v. Board of Supervisors* (1986) 182 Cal.App.3d 1145, 1171; *Riverwatch v. County of San Diego* (1999) 76 Cal.App.4th 1428. Without a complete and accurate description of the project and all of its components, an accurate environmental analysis is not possible. *See, e.g., Santiago County Water Dist. v. County of Orange* (1981) 118 Cal.App.3d 818, 829; *Sierra Club v. City of Orange* (2008) 163 Cal.App.4th 523, 533; *City of Santee v. County of San Diego* (1989) 214 Cal.App.3d 1438, 1450; *Blue Mountains Biodiversity Project v. United States Forest Service*, 161 F.3d 1208, 1215 (9th Cir. 2008).

2

As discussed, below, and in the expert reports submitted by *Custis, EcoNorthwest, Cannon, and Mish* on behalf of AquAlliance, the EIS/EIR fails to comport with these standards. 2

a. The Project / Proposed Action Alternative Description Lacks Detail Necessary for Full Environmental Analysis.

- i. Actual transfer buyers, sellers, modes, amounts, criteria, market demands, availability, and timing, are undisclosed.

The Proposed Action Alternative is poorly specified and needs additional clarity before decision-makers and the public can understand its human and environmental consequences. The Lead Agencies tacitly admit that they have no idea how many acre-feet of water may be made available, by what mechanism the water may be made available (fallowing, groundwater substitution, or crop changes), or to what ultimate use (public health, urban, agricultural) the water may be put.

Glenn Colusa Irrigation District is listed as the largest potential seller, but its General Manager, Thad Bettner, asserted publicly on October 7, 2014 that the district hadn't committed to the 91,000 AF found in Table ES-2 (Potential Sellers). GCID subsequently sent the Bureau a letter that states that GCID plans to pursue its own Groundwater Supplemental Supply Program and that, "It is important for Reclamation to understand that GCID has not approved the operation of any District facilities attributed to the LTWTP Action/Project that is presented in the draft EIR/EIS." ¹ The letters continues stating that, "It is important to underscore that GCID would prioritize pumping during dry and critically dry water years for use in the Groundwater Supplemental Supply Program, and thus wells used under that program would not otherwise be available for the USBR's LTWTP." First, these public and written comments contradict the EIS/EIR on page 3.8-37 where it states that, "The availability of supplies in the seller service area was determined based on data provided by the potential sellers." Second, the largest potential seller in the *2015-2024 Water Transfer Program* is seemingly unable or unwilling to participate in the groundwater substitution component during dry and critically dry years. In addition, GCID has stated that "it will not participate in a groundwater substitution transfer, and for land idling reduce the acreage from 20,000 acres to no more than 10,000 acres." ² Similarly, the Sacramento Suburban Water District received \$2 million from the Governor's Water Action Plan to move groundwater to member agencies that have been "[h]eavily dependent on Folsom reservoir," according to John Woodling of the Sacramento Regional Water Authority. ³ Woodling continues that, "During these dry times, the groundwater basin really is our insurance

3

¹ GCID October 14, 2014.

² GCID November 6, 2014 Board Meeting Item #6.

³ Ortiz, Edward 2014. *Region's water districts split \$14 million for drought relief*. Sacramento Bee November 7, 2014.

policy,” (*Id*). Knowing that smart water managers are very aware of this fact, why would Sacramento Suburban Water District turn around and propose to sell 30,000 AF of water to the out-of-region buyers through groundwater substitution transfers during the Project’s “[d]ry and critically dry years”? In short, the EIS/EIR has no way of knowing what transfers may occur, and when.

3

It is also not possible to determine with confidence just how much water is requested by potential urban and agricultural buyers and how firm the requests are. What are SLDMWA’s specific requests for agricultural or urban uses of Project water? What are the SLDMWA’s present agricultural water demands for the 850,000 acres that it serves? Left to guess at the possible requests for water, we look at the 2009 DWB where there were between 400,000 and 500,000 AF of presumably urban buyer requests alone (which had priority over agricultural purchases, according to the 2009 DWB priorities) and a cumulative total of less than 400,000 AF from willing sellers. It is highly possible, based on the example during the 2009 DWB, that many buyers are not likely to have their needs addressed by the *2015-2024 Water Transfer Program*. How would this affect the project objectives and purpose? How would this affect variable circumstances for other proposed transfers?

4

The EIS/EIR also fails to address the ability and willingness of potential buyers to pay for Project water given the supplies that may be available. Complaints from agricultural water districts were registered in the comments on the Draft Environmental Water Account EIS/EIR and reported in the Final EIS/EIR in January 2004 indicating that they could not compete on price with urban areas buying water from the EWA. Given the absence of priority criteria, will agricultural water buyers identified in Table ES-1 have the ability to buy water when competing with urban districts? Moreover, since buyers are not disclosed in the EIS/EIR for non-CVP river water, these further effects on water market conditions and competition between agricultural and urban sectors is impossible to evaluate. Who are the buyers that may request non-CVP river water, and what are their maximum requests? That DWR is not the CEQA lead agency further complicates the evaluation of competition for water in the EIS/EIR.

Nor does the *2015-2024 Water Transfer Program* prevent rice growers (or other farmers) from “double-dipping,” but actually encourages it. Districts and their growers have opted to turn back their surface supplies from the CVP and the State Water Project and substitute groundwater to cultivate their rice crop—thereby receiving premiums on both their CVP contract surface water as well as their rice crop each fall when it goes to market. There appear to be no caps on water sale prices to prevent windfall profits to sellers of Sacramento Valley water — especially for crops with high market prices, such as rice.

5

The EIS/EIR is inadequate because it fails to identify and analyze the market context for crops as well as water that would ultimately influence the size and scope of the *2015-2024 Water*

*Transfer Program.*⁴ The Project's sellers and buyers are highly sensitive to the influences of prices—prices for water as well as crops such as rice, orchard and vineyard commodities, and other field crops. It is plausible that crop idling would occur more in field crops, while groundwater substitution would be more likely for orchard and vineyard crops. However, high prices for rice—the Sacramento Valley's largest field crop— undermines this logic and leads to substantial groundwater substitution. These potential issues and impacts should be recognized in the EIS/EIR because crop prices are key factors in choices potential water sellers would weigh in deciding whether to idle crops, substitute groundwater, or decline to participate in the Project altogether.

5

To enable a more complete and discrete project description, the EIS/EIR should propose criteria other than price alone to manage allocation of state water resources. The EIS/EIR should consider some priority criteria as was included in the 2009 Drought Water Bank EA/FONSI (p. 3-88). Do both authorizing agencies, the Bureau and DWR, lack criteria to prioritize water transfers? Are transfers approved on a first-come first-serve basis, as generated by market conditions alone? What is the legal or policy basis to act without providing priority criteria? A lack of criteria fails to encourage regions to develop their own water supplies more efficiently and cost-effectively without damage to resources of other regions. If criteria will be applied, these need to be disclosed and analyzed in the EIS/EIR.

Additional uncertainty caused by the incomplete project description includes:

- How many of the proposed transfers would be one year in duration, multi-year, or permanent. How will the duration of any agreement be determined? The duration of a transfer agreement will have dramatic effects on the water market as well as the environmental impact analysis.
- The EIS/EIR purports to be a 10 year project, but is there an actual sunset date, since it continues serially in multiple years? Could any transfer be approved in the next 10 years that would extend beyond 2024?
- The proposed program provides no way to know what ultimate use transferred water will be put to; nor does the EIS/EIR provide any way to know what activities may occur on idled cropland. The EIS/EIR assumptions on these points are inherently incomplete and fail to support any discrete environmental analysis.

6

In sum, the proposed program provides no way to know which transfers may or may not occur, individually or cumulatively. The lack of a stable and finite project description undermines the entire EIS/EIR. As discussed further, below, description of the environmental setting, evaluation of potentially significant impacts, and formulation of mitigation measures, among other issues, all are rendered unduly imprecise, deferred, and incomplete, subject to the theoretical transfers taking shape at some, unknown, future time.

⁴ EcoNorthwest (Exhibit B).

ii. Historic transfer data is excluded.

Absent from the DEIS/EIR are any of the required monitoring reports from previous transfer projects. *See, e.g., Citizens for East Shore Parks v. State Lands Commission* (2010) 48 Cal.App.4th 549; *Communities for a Better Environment v. South Coast Air Quality Mgmt. Dist.* (2010) 48 Cal.App.4th 310. Without the required monitoring reports, the public is left in the dark regarding this new proposal to sell up to 600,000 AF annually over a 10 year period. No information is provided regarding the impacts to downstream users, wells near production wells, the Sacramento River and its tributaries, refuges, water quality, special status species and the San Francisco Bay Delta Estuary from past CVP transfers or cumulatively including non-CVP water transfers in the area of origin. For example, groundwater substitution transfers and transfers that result in reduced flows in combination with below normal water years are known to have to have the potential for significant impacts on water quality, fish, wildlife and the flows in the Sacramento River and its tributaries. Providing all such documentation of the terms, conditions, effects, and outcomes of prior transfers is integral to understanding the proposed Project.

7

b. The Proposed Project is in Fact a Proposed Program.

The lack of any stable, discrete, project description, at best, renders the proposed project a “program,” rather than any specific project itself. “[A] *program* EIR is distinct from a *project* EIR, which is prepared for a specific project and must examine in detail site-specific considerations.” *Center for Sierra Nevada Conservation v. County of El Dorado* (2012) 202 Cal.App.4th 1156, 1184. As discussed further, below, this EIS/EIR does not and cannot complete site-specific and project-specific analysis of unknown transfers at unknown times. Buyers and sellers have “expressed interest,” but no specific transfers or combination of transfers are proposed, and we don’t know which may be proposed or ultimately approved.

8

Put differently, the EIS/EIR project description is not simply inadequate: the EIS/EIR fails to propose or approve any project at all. Instead, the EIS/EIR should be recharacterized and revised as a program EIS/EIR. Indeed, agency documents have referred to this program, as such, for years. (E.g., Federal Register /Vol. 75, No. 248 /Tuesday, December 28, 2010 /Notices *Long-Term North to South Water Transfer Program, Sacramento County, CA*; Final EA/FONSI for 2010-2011 Water Transfer Program.⁵) And other external sources also support the proposition that this EIS/EIR does not and cannot review and approve specific transfers:

“Each transfer is unique and must be evaluated individually to determine the quantity and timing of real water made available.” (BDCP DEIR at 1E-2.)

“Although this document seeks to identify in the best and most complete way possible the information needed for transfer approval, to both expedite that approval and to

⁵ <http://www.usbr.gov/newsroom/newsrelease/detail.cfm?RecordID=31781>

reduce participant uncertainty, each transfer is unique and must be considered on its individual factual merits, using all the information that is available at the time of transfer approval and execution of the conveyance or letter of agreement with the respective Project Agency in accordance with the applicable legal requirements. This document does not pre-determine those needs or those facts and does not foreclose the requirement and consideration of additional information.” (Draft Technical Information for Preparing Water Transfer Proposals (“DTIPWTP”) 2014.)

8

Indeed, the Bureau and DWR have known for over a decade that programmatic environmental review was and is necessary for water transfers from the Sacramento Valley. The following examples highlight the Bureau and DWR’s deficiencies in complying with NEPA and CEQA.

- a. The Sacramento Valley Water Management Agreement was signed in 2002, and the need for a programmatic EIS/EIR was clear at that time it was initiated but never completed.
- b. In 2000, the Governor’s Advisory Drought Planning Panel report, *Critical Water Shortage Contingency Plan* promised a program EIR on a drought-response water transfer program, but was never undertaken.
- c. Sacramento Valley Integrated Regional Water Management Plan (2006).
- d. The Sacramento Valley Water Management Plan (2007).
- e. The CVPIA mandates the Bureau contribute to the State of California’s *long-term* efforts to protect the San Francisco Bay/Sacramento-San Joaquin Delta Estuary, among other things. (EIS/EIR 1-10.)

9

Accordingly, the EIS/EIR should be revised to state that it does not and cannot constitute sufficient environmental review of any particular, as-of-yet-unknown, water transfer proposal; and instead be revised, restructured, and recirculated to provide programmatic policies, criteria, and first-tier environmental review.

- c. The EIS/EIR Improperly Segments Environmental Review of the Whole of this Program.

As discussed throughout these comments, the proposed Project does not exist in a vacuum, but rather is another transfer program in a series of many that have been termed either “temporary,” “short term,” “emergency,” or “one-time” water transfers, and is cumulative to numerous broad programs or plans to develop regional groundwater resources and a conjunctive use system. The *2015-2024 Water Transfer Program* is also only one of several proposed and existing projects that affect the regional aquifers.

10

For example, the proposed Project is, in fact, just one project piece required to implement the Sacramento Valley Water Management Agreement (“SVWMA”). The Bureau has publically

stated the need to prepare programmatic environmental review for the SVWMA for over a decade, and the present EIS/EIR covers a significant portion of the program agreed to under the SVWMA. In 2003, the Bureau published an NOI/NOP for a “Short-term Sacramento Valley Water Management Program EIS/EIR.” (68 Federal Register 46218 (Aug 5, 2003).) As summarized on the Bureau’s current website:

The Short-term phase of the SVWM Program resolves water quality and water rights issues arising from the need to meet the flow-related water quality objectives of the 1995 Bay-Delta Water Quality Control Plan and the State Water Resources Control Board's Phase 8 Water Rights Hearing process, and would promote better water management in the Sacramento Valley and develop additional water supplies through a cooperative water management partnership. Program participants include Reclamation, DWR, Northern California Water Association, San Luis & Delta-Mendota Water Authority, some Sacramento Valley water users, and Central Valley Project and State Water Project contractors. SVWM Program actions would be locally-proposed projects and actions that include the development of groundwater to substitute for surface water supplies, conjunctive use of groundwater and surface water, refurbish existing groundwater extraction wells, install groundwater monitoring stations, install new groundwater extraction wells, reservoir re-operation, system improvements such as canal lining, tailwater recovery, and improved operations, or surface and groundwater planning studies. These short-term projects and actions would be implemented for a period of 10 years in areas of Shasta, Butte, Sutter, Glenn, Tehama, Colusa, Sacramento, Placer, and Yolo counties.⁶

10

The resounding parallels between the SVWMA NOI/NOP and the presently proposed project are not merely coincidence: they are a piece of the same program. In fact, the SVWMA continues to require the Bureau and SLDMWA to facilitate water transfers through crop idling or groundwater substitution:

Management Tools for this Agreement. A key to accomplishing the goals of this Agreement will be the identification and implementation of a “palette” of voluntary water management measures (including cost and yield data) that could be implemented to develop increased water supply, reliability, and operational flexibility. Some of the measures that may be included in the palette are:

...

(v) Transfers and exchanges among Upstream Water Users and with the CVP and SWP water contractors, either for water from specific reservoirs, or by substituting groundwater for surface water . . . ⁷

⁶ http://www.usbr.gov/mp/nepa/nepa_projdetails.cfm?Project_ID=788

⁷ http://www.norcalwater.org/wp-content/uploads/2010/12/sac_valley_water_mgmt_agrmt_new.pdf

It is abundantly clear that the Bureau and SLDMWA are proposing a program through the present draft EIS/EIR to implement this management tool, as required by the SVWMA. But neither CEQA nor NEPA permit this approach of segmenting and piecemealing review of the whole of a project down to its component parts. The water transfers proposed for this project will directly advance SVWMA implementation, and the Bureau and DWR must complete environmental review of the whole of the program, as first proposed in 2003 but since abandoned. For example, the draft EIS/EIR does not reveal that the current Project is part of a much larger set of plans to develop groundwater in the region, to develop a “conjunctive” system for the region, and to integrate northern California’s groundwater into the state’s water supply.

11

In this vein the U.S. Department of Interior, 2006. Grant Assistance Agreement, *Stony Creek Fan Conjunctive Water Management Program and Regional Integration of the lower Tuscan Groundwater formation* laid bare the intentions of the Bureau and its largest Sacramento Valley water district partner, Glenn Colusa Irrigation District, to take over the Tuscan groundwater basin to further the implementation of the SVWMA, stating:

GCID shall define three hypothetical water delivery systems from the State Water Project (Oroville), the Central Valley Project (Shasta) and the Orland Project reservoirs sufficient to provide full and reliable surface water delivery to parties now pumping from the Lower Tuscan Formation. The purpose of this activity is to describe and compare the performance of three alternative ways of furnishing a substitute surface water supply to the current Lower Tuscan Formation groundwater users to eliminate the risks to them of more aggressive pumping from the Formation and to optimize conjunctive management of the Sacramento Valley water resources.

d. The Project Description Contains an Inadequate Statement of Objectives, Purpose, and Need.

The lack of a stable project description/proposed alternative, as discussed, above, further obfuscates the need for the Project. Further, without programmatic criteria to prioritize certain transfers, the public is not provided with even a basic understanding of the need for the Project. The importance of this section in a NEPA document can’t be overstated. “It establishes why the agency is proposing to spend large amounts of taxpayers' money while at the same time causing significant environmental impacts... As importantly, the project purpose and need drives the process for alternatives consideration, in-depth analysis, and ultimate selection. The Council on Environmental Quality (CEQ) regulations require that the EIS address the "no-action" alternative and "rigorously explore and objectively evaluate all reasonable alternatives." Furthermore, a well-justified purpose and need is vital to meeting the requirements of Section 4(f) (49 U.S.C. 303) and the Executive Orders on Wetlands (E.O. 11990) and Floodplains (E.O. 11988) and the Section 404(b)(1) Guidelines. Without a well-defined, well-established and well-

12

justified purpose and need, it will be difficult to determine which alternatives are reasonable, prudent and practicable, and it may be impossible to dismiss the no-build alternative”⁸

With the importance of a Purpose and Need statement revealed above, the Project’s version for purposes of NEPA states that, “The purpose of the Proposed Action is to facilitate and approve voluntary water transfers from willing sellers upstream of the Delta to water users south of the Delta and in the San Francisco Bay Area. Water users have the need for immediately implementable and flexible supplemental water supplies to alleviate shortages,” (p. 1-2). Noticeably missing from this section of the EIS/EIR is a statement about the Bureau’s purpose and need, not the buyers’ purpose and need. The omission of *any* need on the Bureau’s part for this Project highlights the conflicts in the Bureau’s mission, deficiencies in planning for both the short and long term, and the inadequacy of the EIS/EIR that should provide the public with the basis for the development of the range of reasonable alternatives and the identification and eventual selection of a preferred alternative. The *Reclamation’s NEPA Handbook* (2012) stresses that, “The need for an accurate (and adequate) purpose and need statement early in the NEPA process cannot be overstated. This statement gives direction to the entire process and ensures alternatives are designed to address project goals.” (p.11-1)

12

For purposes of CEQA, the Project Objectives (p. 1-2) go on to state that,

SLDMWA has developed the following objectives for long-term water transfers through 2024:

- Develop supplemental water supply for member agencies during times of CVP shortages to meet existing demands.
- Meet the need of member agencies for a water supply that is immediately implementable and flexible and can respond to changes in hydrologic conditions and CVP allocations.

Because shortages are expected due to hydrologic conditions, climatic variability, and regulatory requirements, transfers are needed to meet water demands.

But merely asserting that there are “demands” from their member lacks context, specificity, and rigor. It also fails to mention the need of the non-member buying agencies involved in the Project.

Some context for the policy failures that lead to the stated need for the Project must be presented. First, the hydrologic conditions described on pages ES-1, 1-1, and 1-2 almost always

13

⁸ Federal Transportation and Highway Administration, 1990. *NEPA and Transportation Decisionmaking: The Importance of Purpose and Need in Environmental Documents*.
<http://www.environment.fhwa.dot.gov/projdev/tdmneed.asp>

apply to the entire state, including the region where sellers are sought, not just the areas served by SLDMWA and non-member buyers as presented here. Second, SLDMWA has chronic water shortages due to its contractors’ junior position in water rights, risks taken by growers to plant permanent crops, and serious long-term overdraft in its service area. Where is this divulged? Third, SLDMWA or its member agencies have sought to buy and actually procured water in many past water years to make up for poor planning and risky business decisions, which violates CEQA’s prohibition against segmenting a project to evade proper environmental review.⁹ The habitual nature of the transfers is acknowledged on pages ES-1 and 1-1 stating, “In the past decades, water entities have been implementing water transfers to supplement available water supplies to serve existing demands, and such transfers have become a common tool in water resource planning.” (See Table 1 for an attempt at documenting transfers since actual numbers are not disclosed in the EIS/EIR).

13

The Bureau and DWR’s facilitation of so-called “temporary” annual transfers in 12 of the last 14 years is illustrated in Table 1 (2014 transfer totals have not been tallied to date).

Table 1. The table is based on one from Western Canal Water District’s Negative Declaration for a 2010 water transfer.

Past Water Transfers from the Sacramento Valley Through the Delta in TAF Annually*													
Water Year Type **	Dry	Dry	AN	BN	BN	Wet	Dry	Critical	Dry	BN	Wet	BN	Dry
Program	2001	2002	2003	2004	2005	2006	2007	2008 ¹⁰	2009	2010	2011	2012	2013
DWR Drought Water Bank/Dry Year Programs	138	22	11	0.5	0	0	0	0	74	0	0	0	0
Enviro Water Acct	80	145	70	120	5	0	147	60	60	60	0	60	60
Others (CVP, SWP, Yuba, inter alia)	160	5	125	0	0	0	0	173	140	243	0	190	210
Totals	378	172	206	120.5	5	0	147	233	274* **	303	0	250	270

14

*Table reflects gross AF purchased prior to 20% Delta carriage loss (i.e., actual amounts pumped at Delta are 20% less)
 ** Based on DWR’s measured unimpaired runoff (in million acre-feet)
 Abbreviations: AN - Above normal year type and BN - Below normal year type (<http://cdec.water.ca.gov/cgi-progs/iodir/wsihist>)
 *** The 2015-2024 Water Transfer Program’s EIS/EIR contradicts the 274,000 AF total for 2009 on EIS/EIR page 1-16 that states that the CVP portion alone during 2009 was 390,000 AF.

The Project has become an extension of the so-called “temporary” annual transfers based on the demands of junior water rights holders who expect to receive little contract water during dry years. The low priority of their junior water service contracts within the Central Valley Project leaves their imported surface supplies in question year-to-year. It is the normal and appropriate function of California’s system of water rights law that makes it so. Yet the efforts

⁹ Laurel Heights Improvement Association v. Regents of the University of California, 1988, 47 Cal.3d 376
¹⁰ The Environmental Water Account ended in 2007 (Bay Delta Conservation Plan Draft EIS/EIR 2013). The figures that continue in this row are based on a long-term contract with the Yuba County Water Agency to sell water.-

of the Bureau and DWR to oversee, approve, and facilitate water sales from the Sacramento, Feather, and Yuba rivers with fallowing and groundwater substitution are only intended to benefit the few western San Joaquin Valley farmers whose contractual surface water rights have always been less reliable than most—and whose lands are the most problematic for irrigation. These growers have chosen to harden demand by planting permanent crops, a very questionable business decision, but the Bureau fails to explain why this “tail” in water rights is wagging the dog.

14

e. The Project Description does Not Include all Project Components.

i. Carriage water.

The EIS/EIR’s description of and reliance on “carriage water” is completely uncertain, undefined, and provides no meaningful information to the public. The EIS/EIR states that “Outflows would generally increase during the transfer period because carriage water would become additional Delta outflow.” (EIS/EIR 3.2-39.) The EIS/EIR also asserts that, “Carriage water (a portion of the transfer that is not diverted in the Delta and becomes Delta outflow) will be used to maintain water quality in the Delta.” (EIS/EIR 2-29.) Elsewhere the EIS/EIR references 20% carriage losses for CCWD and SLDMWA in the EIS/EIR (3.2-39, 3.2-57-58, and B-6), while prior documents have used higher estimates:

Historically, approximately 20-30% of the water transferred through the Delta would be necessary to enable the maintenance of water quality standards, which are based largely upon the total amount of water moving through the Bay-Delta system. This water, which is not available for delivery to Buyers, is known as “carriage water.” Given historically dry conditions prevailing in 2014, DWR estimates that carriage losses could be higher.

15

(Biggs West Gridley 2014 Water Transfer Neg Dec, p. 4)(Exhibit I). A Bureau spreadsheet that documents the final transfer numbers for 2013 clearly demonstrates that the 30% figure was used for carriage losses.¹¹ The spreadsheet further reveals that there are additional water deductions that were made prior to delivery in 2013 for DWR Conveyance Loss (2%) and Warren Act Conveyance Loss (3%). When all the water deductions are tallied for stream depletion, carriage losses, and the two conveyance losses, the actual water available for delivery when groundwater substitution is used is 53%. This is not presented in the EIS/EIR, which allows the Lead Agencies to overestimate the amount of water that is delivered through the Delta to Buyers and therefore the economic benefits of the *2015-2024 Water Transfer Program*. What is lacking is any meaningful discussion of the need for, role, availability, and effect of carriage water and conveyance losses in any transfer in the EIS/EIR. Without such information it is not possible to determine the water quality and supply effects of the program.

¹¹ Bureau of Reclamation, 2013-12-17 2013 Total Pumpage (FINAL) nlw.xlsx (Exhibit J)

ii. Monitoring and production wells.

The identity and locations of all wells that will be used to monitor groundwater substitution transfer pumping impacts are unknown. The EIS/EIR must include proposed transfer well locations that are sufficiently accurate to allow for determination of distances between the wells and areas of potential impact. These are integral project features that must be disclosed in detail prior to any meaningful effects analysis.

16

In 2009, GCID installed four production wells to extract 26,530 AF of groundwater as part of its *Stony Creek Fan Aquifer Performance Testing Plan*. Other districts have also installed production wells, most with public funds, that have been used for past transfers such as Anderson/Cottonwood Irrigation District, Butte Water District, and RD-108. To the extent those wells and any others would be used in this project, they must be considered to be part of the whole of the action, and disclosed and analyzed herein.

i. "Other" transfers.

The EIS/EIR states that, "Other transfers not included in this EIS/EIR could occur during the same time period, subject to their own environmental review (as necessary)." (EIS/EIR 1-2.) In other words, not only is the EIS/EIR unclear precisely about which transfers are likely to occur and are analyzed in this EIR/EIR, it also leaves open-ended the prospect of some transfers not being covered by the EIS/EIR. This apparent piecemealing of transfer projects short-circuits comprehensive environmental review.

17

f. The Project Description Fails to Include Sufficient Locations, Maps, and Boundaries.

The project description must show the location of the project, its component parts, and the affected environmental features. CEQA Guidelines § 15124(a).

Maps are needed of each seller service area at a scale that allows for reasonably accurate measurement of distances between the groundwater substitution transfer wells and surface water features, other non-participating wells, proposed monitoring wells, fisheries, vegetation and wildlife areas, critical surface structures, and regional economic features. Maps with rates and times of stream depletion by longitudinal channel section are needed to allow for an adequate review of the Draft EIR/EIS conclusion of less than significant and reasonable impacts with no injury. These maps are also needed to evaluate the specific locations for monitoring potential impacts. Thus, detailed maps that show the locations of the monitoring wells and the areas of potential impact along with the rates and seasons of anticipated stream depletion are needed for each seller service area. These maps are also needed to allow for evaluation of the cumulative effects whenever pumping by multiple sellers can impact the same resource. The only maps provided by the Draft EIS/EIR that show the location of the groundwater substitution transfer wells, and the rivers and streams potentially impacted are the simulated drawdown Figures 3.3-26 to 3.3-31, which are at a scale of approximately 1 inch to 18 miles. The lack of maps with sufficient detail to see the relationship between the wells and the surface water

18

features prevents adequate review of the Draft EIS/EIR analysis to determine groundwater and surface water impacts. 18

Furthermore, figure 3.1-1, mapping the project area, is impossible to read and determine where each seller and buyer service area actually lies. Nor does the figure itself actually include many geographic points of reference used throughout the EIS/EIR. The EIS/EIR, for example, states that “Pelger MCW is located on the east side of the Sacramento River near Robbins (Figure 3.1-1.)” (EIS/EIR at 3.1-7.) But Robbins is not on the map, and the Pelger MCW is virtually impossible to locate on Figure 3.1-1. Similarly, the EIS/EIR states that the Sacramento River is impaired from Keswick dam to the Delta, but the EIS/EIR contains no description or map showing where Keswick dam is located, or any map enabling an understanding of the geographic scope of this water quality impairment. This problem repeats for literally dozens of existing environmental features described in the EIS/EIR. And, this problem is compounded by the unstable nature of the project description itself, leaving the EIS/EIR to string together multiple combinations of place names where transfers may or may not be imported or exported, and leaving the reader to continually search out secondary information to attempt to follow the EIS/EIR’s terse and convoluted descriptions. A clear explanation, with visual aids, of the affected environment, including all local creeks and streams, and transfer water routes, is necessary to enable any member of the general public to grasp the potential types and locations of environmental impacts caused by the proposed program. 19

II. The EIS/EIR State Lead Agency Should be DWR, Not SLDMWA.

SLDMWA is not the proper Lead Agency for the Project. California Environmental Quality Act (“CEQA”) Guidelines sections 15367 and 15051 require that the California Department of Water Resources (“DWR”), as the operator of the California Aqueduct and who has responsibility to protect the public health and safety and the financial security of bondholders with respect to the aqueduct, is the more appropriate lead agency. In *PCL v DWR*, the court found that DWR’s attempt to delegate lead agency authority impermissibly insulated the department from “public awareness and possible reaction to the individual members’ environmental and economic values.”¹² 20

Pursuant to CEQA, ““lead agency” means the public agency which has the principal responsibility for carrying out or approving a project which may have a significant effect upon the environment.” (Public Res. Code § 21067.) As such, the lead agency must have authority to require imposition of alternatives and mitigation measures to reduce or avoid significant project effects, and must have the authority to disapprove of the project altogether. Here, the DWR clearly fits this description. As the EIS/EIR states, “[t]hese transfers require approval from Reclamation and/or Department of Water Resources (DWR).” (EIS/EIR 1-2.) Additionally, the

¹² *Planning and Conservation League et al. v Department of Water Resources* (2000) 83 Cal.App.4th 892, 907, citing *Kleist v. City of Glendale* (1976) 56 Cal. App. 3d 770, 779.

EIS/EIR reveals the obvious and long-standing relationship between the Bureau and DWR in facilitating surface water transfers. The Bureau and DWR have collaborated on each DTIWT publication, which provides specific environmental considerations for transfer proposals; are said to have “sponsored drought-related programs” together; have created the joint EIS/EIR for the Environmental Water Account (“EWA”); and “cooperatively implemented the 2009 Drought Water Bank.”

20

SLDMWA should not serve as the lead agency. The *2015-2024 Water Transfer Program* has the potential to impact the long-term water supplies, environment, and economies in many California counties far removed from the SLDMWA geographic boundaries. With SLDMWA designated as the lead agency, and no potential sellers or source counties designated as responsible agencies, the process is unreasonably biased toward the narrow functional interests of SLDMWA and its member agencies. According to the EIS/EIR, the SLDMWA’s role is to “[h]elp negotiate transfers in years when the member agencies could experience shortages.” (EIS/EIR 1-1.) Helping to negotiate a transfer is a wholly different role than that of a lead agency with approval authority over a project. All of SLDMWA’s purposes and powers are centered on providing benefit to member organizations,¹³ and do not implement the Sustainable Groundwater Management Act.¹⁴ Not only would SLDMWA be advocating on behalf of its members in this process, but nothing provided in the EIS/EIR suggests that it has authority to require mitigation measures or alternatives to reduce or avoid significant project impacts, for example, to groundwater resources in the seller service area, as such limitations would clearly be contrary to the specific interests of the SLDMWA members.

Importantly, DWR not only has jurisdiction over the SLDMWA transfers in ways that SLDMWA does not, but also DWR has review and approval authority over potential transfers outside of the SLDMWA altogether, including, for example, the East Bay Municipal Utilities District, as well as “[o]ther transfers not included in this EIS/EIR [that] could occur during the same time period, subject to their own environmental review (as necessary).” (EIS/EIR 1-2.) Environmental review of transfers should be unified and comprehensive, and cumulative across both geography and over time in a way that DWR and not SLDMWA can provide.

III. The EIS/EIR Fails to Completely and Accurately Describe the Affected Environmental Setting and Baseline Conditions.

21

A complete and accurate description of the existing and affected environmental setting is critical for an adequate evaluation of impacts to it. See *e.g. San Joaquin Raptor/Wildlife Rescue Ctr. v. County of Stanislaus* (1994) 27 Cal.App.4th 713; *Galante Vineyards v. Monterey Peninsula Water Mgmt. Dist.* (1997) 60 Cal.App.4th 1109, 1122; *County of Amador v. El Dorado County*

¹³ SLDMWA JPA, para. 6, pp. 4-7.

¹⁴ StAmant 2014. Letter to Bureau of Reclamation and SLDMWA re the 2015-2024 Water Transfer Program.

Water Agency (1999) 76 Cal.App.4th 931, 955; *Cadiz Land Co. v. Rail Cycle* (2000) 83 Cal.App.4th 74, 94.

21

As discussed, below, and in the expert reports submitted by *Custis*, *EcoNorthwest*, *Cannon*, and *Mish* on behalf of AquAlliance, the EIS/EIR fails to comport with these standards.

a. The EIS/EIR Fails to Describe Existing Physical Conditions.

i. Groundwater Supply

The EIS/EIR fails to provide a comprehensive assessment of the historic change in groundwater storage in the Sacramento Valley groundwater basin, and other seller sources areas within the proposed 10-year groundwater substitution transfer project. Historic change and current groundwater contour maps are critical to establishing an environmental baseline for the groundwater substitution transfers. The EIS/EIR uses SACFEM2013 simulations of groundwater substitution transfer pumping effects for WY 1970 to WY 2003, but the discussion of the simulation didn't provide specifics on how the model simulated the current conditions of the Sacramento Valley groundwater system or the potential impacts from the 10-year groundwater substitution transfer project based on current conditions. Again, The EIS/EIR relies on only modeling to consider impacts from the Project when it should disclose the results from actual monitoring and reporting for water transfer conducted in 12 of the last 14 years.

22

The EIS/EIR concludes that the Sacramento Valley basin's groundwater storage has been relatively constant over the long term, decreasing during dry years and increasing during wetter periods, but the EIR/EIS ignores more recent information and study (e.g. Brush 2013a and 2013b, NCWA, 2014a and 2014b). According to the BDCP EIS/EIR:

Some locales show the early signs of persistent drawdown, including the northern Sacramento County area, areas near Chico, and on the far west side of the Sacramento Valley in Glenn County where water demands are met primarily, and in some locales exclusively, by groundwater. These could be early signs that the limits of sustainable groundwater use have been reached in these areas."

(BDCP EIS/EIR at 7-13.) The Draft EIS/EIR provides only one groundwater elevation map of the Sacramento Valley groundwater basin, Figure 3.3-4, which shows contours only from selected wells that omit many depths and areas. The Draft EIS/EIR doesn't provide maps showing groundwater elevations, or depth to groundwater, for groundwater substitution transfer seller areas in Sutter, Yolo, Yuba, and Sacramento counties. The DWR provides on a web site a number of additional groundwater level and depth to groundwater maps that the EIS/EIR should use to help complete its description of the affected environment.¹⁵

23

¹⁵http://www.water.ca.gov/groundwater/data_and_monitoring/northern_region/GroundwaterLevel/gw_level_monitoring.cfm#Well%20Depth%20Summary%20Maps

Presented below are tables that illustrate maximum and average groundwater elevation decreases for Butte, Colusa, Glenn, and Tehama counties at three aquifer levels in the Sacramento Valley between the fall of 2004 and 2013. (Id).

County Fall '04 - '13	Deep Wells (Max decrease gwe)	Deep Wells (Avg. decrease gwe)
Butte	-11.4	-8.8
Colusa	-31.2	-20.4
Glenn	-60.7	-37.7
Tehama	-19.5	-6.6

County Fall '04 - '13	Intermediate Wells (Max decrease gwe)	Intermediate Wells (Avg. decrease gwe)
Butte	-21.8	-6.5
Colusa	-39.1	-16.0
Glenn	-40.2	-14.5
Tehama	-20.1	-7.9

County Fall '04 - '13	Shallow Wells (Max decrease gwe)	Shallow Wells (Avg. decrease gwe)
Butte	-13.3	-3.2
Colusa	-20.9	-3.8
Glenn	-44.4	-8.1
Tehama	-15.7	-6.6

Below are the results from DWR's spring monitoring for Sacramento Valley groundwater basin from 2004 to 2014.

County Spring '04 - '14	Deep Wells (Max decrease gwe)	Deep Wells (Avg. decrease gwe)
Butte	-20.8	-14.6
Colusa	-26.9	-12.6
Glenn	-49.4	-29.2
Tehama	-6.1	-5.3

County Spring '04 - '14	Intermediate Wells (Max decrease gwe)	Intermediate Wells (Avg. decrease gwe)
Butte	-25.6	-12.8
Colusa	-49.9	-15.4
Glenn	-54.5	-21.7
Tehama	-16.2	-7.9

County Spring '04 - '14	Shallow Wells (Max decrease gwe)	Shallow Wells (Avg. decrease gwe)
Butte	-23.8	-7.6
Colusa	-25.3	-12.9
Glenn	-46.5	-12.6
Tehama	-38.6	-10.8

23

The DWR data clearly present a different picture of the condition of the Sacramento Valley groundwater basin over time than what is provided in the EIS/EIR. This must be corrected and considered in the NEPA and CEQA process.

The EIS/EIR omits other critical information needed to understand the project's impacts to area groundwater, including but not limited to:

- the distances between the transfer well(s) and surface water features;
- the number of non-participating wells in the vicinity of the transfer wells that may be impacted by the pumping; and,
- the distance between the transfer wells and non-participant wells that may be impacted by the transfer pumping, including domestic, public water supply and agricultural wells.

24

The EIS/EIR assumes that, "The groundwater modeling results indicate that shallow groundwater is typically deeper than 15 feet in most locations under existing conditions, and often substantially deeper." (3.8-32.) However, existing hydrologic condition documents clearly show Depth to Groundwater levels in shallow portions of the aquifer system that are <15' from the surface.

- The Chart titled **Depth to Water by Sub-Inventory Unit (SIU) on 2014_10_Summary_Table.PDF** page 2/2 shows the Average Depth to Water (feet) in March through October 2014. 7 of 16 Sub-Inventory Units ("SIUs") in Butte County show average groundwater levels <15' from the surface at some time of the year.¹⁶
- November 2014 Adobe spreadsheets show numerous monitoring wells with water levels closer than 10' to the surface. The wells are located in Butte County SIUs designated under the county Basin Management Objective ("BMO") program. While some of the SIUs are corresponding to an Irrigation District primarily served by surface water, the Butte Sink, Cherokee, North Yuba, Angel Slough, Llano Seco and M&T SIUs have naturally occurring water levels <10'. All 3 pages show ground surface to water surface (feet).¹⁷

25

¹⁶https://www.buttecounty.net/wrcdocs/Programs/Monitoring/GWLevels/2014/2014_10_Summary_Table.pdf
https://www.buttecounty.net/wrcdocs/Programs/Monitoring/GWLevels/2014/2014_10_Data_Summary_Update.pdf (Exhibit K)

¹⁷ 2014 Monthly Groundwater Depth to Water- CASGEM:
https://www.buttecounty.net/wrcdocs/Programs/Monitoring/GWLevels/2014/2014_10_Data_Summary_Update.pdf (Exhibit K)

- The January 2014 *BUTTE COUNTY DOMESTIC WELL DEPTH SUMMARY* shows the 10' Depth to Groundwater Contour lines in the lower portion of the map.¹⁸
- The January 2014 *COLUSA COUNTY DOMESTIC WELL DEPTH SUMMARY* shows the 10' Depth to Groundwater Contour lines in large portions of the county.¹⁹
- The January 2014 *GLENN COUNTY DOMESTIC WELL DEPTH SUMMARY* shows the 10' Depth to Groundwater Contour lines in the lower portion of the map.²⁰

25

Dan Wendell of The Nature Conservancy, a panelist at a workshop held by the California Natural Resources Agency, the California Department of Food and Agriculture, and California EPA on March 24, 2014, presented a similar picture as the county summaries above, but also raised the alarm about the existing, significant streamflow losses from groundwater pumping and, even more significantly, how long it takes for those losses to appear:

“The Sacramento Valley still has water levels that are fairly shallow,” he said. “There are numerous perennial streams and healthy ecosystems, and the basin is largely within a reasonable definition of sustainable groundwater yield. However, since the 1940s, groundwater discharge to streams in this area has decreased by about 600,000 acre-feet per year due to groundwater pumping, and it’s going to decrease an additional 600,000 acre-feet in coming years under 2009 status quo conditions due to the time it takes effects of groundwater pumping to reach streams. It takes years to decades, our work is showing.”²¹

26

What areas in the Sellers’ region were used to reach the EIS/EIR conclusion that “[i]ndicate that shallow groundwater is typically deeper than 15 feet”? What prevented the analysis from disclosing the many miles of riparian habitat in the Sacramento Valley that indicate that riparian forest vegetation remains healthy with groundwater levels shallower than 15 feet? As we presented above, there are many areas in the Sellers’ region that have groundwater higher than 15 feet below ground surface.

In addition, the EIS/EIR fails to provide recharge data for the aquifers. Professor Karin Hoover, Assistant Professor of hydrology, hydrogeology, and surficial processes from CSU Chico, found

27

¹⁸ Butte County shallow Groundwater Contours:

[www.water.ca.gov/groundwater/data_and_monitoring/northern_region/GroundwaterLevel/WellDepthSummaryMaps/Domestic BUTTE.pdf](http://www.water.ca.gov/groundwater/data_and_monitoring/northern_region/GroundwaterLevel/WellDepthSummaryMaps/Domestic_BUTTE.pdf) (Exhibit L)

¹⁹ Colusa County shallow Groundwater Contours:

[www.water.ca.gov/groundwater/data_and_monitoring/northern_region/GroundwaterLevel/WellDepthSummaryMaps/Domestic COLUSA.pdf](http://www.water.ca.gov/groundwater/data_and_monitoring/northern_region/GroundwaterLevel/WellDepthSummaryMaps/Domestic_COLUSA.pdf) (Exhibit M)

²⁰ Glenn County shallow Groundwater Contours:

[www.water.ca.gov/groundwater/data_and_monitoring/northern_region/GroundwaterLevel/WellDepthSummaryMaps/Domestic GLENN.pdf](http://www.water.ca.gov/groundwater/data_and_monitoring/northern_region/GroundwaterLevel/WellDepthSummaryMaps/Domestic_GLENN.pdf) (Exhibit N)

²¹ <http://mavensnotebook.com/2014/04/28/groundwater-management-workshop-part-1-sustainable-groundwater-management-panel/> (Exhibit O)

in 2008 that, “Although regional measured groundwater levels are purported to ‘recover’ during the winter months (Technical Memorandum 3), data from Spangler (2002) indicate that recovery levels are somewhat less than levels of drawdown, suggesting that, in general, water levels are declining.” According to Dudley, “Test results indicate that the ‘age’ of the groundwater samples ranges from less than 100 years to tens of thousands of years. In general, the more shallow wells in the Lower Tuscan Formation along the eastern margin of the valley have the ‘youngest’ water and the deeper wells in the western and southern portions of the valley have the ‘oldest’ water,” adding that “the youngest groundwater in the Lower Tuscan Formation is probably nearest to recharge areas.” (2005). “This implies that there is currently no active recharge to the Lower Tuscan aquifer system (M.D. Sullivan, personal communication, 2004),” explains Dr. Hoover. “If this is the case, then water in the Lower Tuscan system may constitute fossil water with no known modern recharge mechanism, and, once it is extracted, it is gone as a resource,” (Hoover 2008).²²

27

ii. Groundwater Quality

The Draft EIS/EIR discusses the potential for impacts to groundwater quality by migration of contaminants as a result of groundwater substitution pumping, but provides only a general description of the current condition of groundwater quality. No maps are provided that show the baseline groundwater quality and known areas of poor or contaminated groundwater, or from all areas where groundwater pumping may occur. Groundwater quality information on the Sacramento Valley area is available from existing reports by the USGS (1984, 2008b, 2010, and 2011) and Northern California Water Association (NCWA, 2014c). Determination of groundwater quality prior to pumping is critical to avoiding significant adverse impacts, both to adjacent groundwater users impacted by migrating contaminants, as well as surface water potentially impaired by contaminated runoff from irrigated agriculture or other uses.

28

There are numerous hazardous waste plumes in Butte County, which could easily migrate with the potential increased groundwater pumping proposed for the Project. The State Department of Toxics Control and the Regional Water Resources Control Boards have a great deal of information readily available for all counties involved with the proposed Project. Fluctuating domestic wells can lead to serious contamination from heavy metals and non-aqueous fluids. Because the Bureau fails to disclose basic standards for the mitigation and monitoring requirements, it is unknown if hazardous plumes in the areas of origin will be monitored or not.

29

²² Spangler, Deborah L. 2002. *The Characterization of the Butte Basin Aquifer System, Butte County, California*. Thesis submitted to California State University, Chico; Dudley, Toccoy et al. 2005. *Seeking an Understanding of the Groundwater Aquifer Systems in the Northern Sacramento Valley: An Update*; Hoover, Karin A. 2008. *Concerns Regarding the Plan for Aquifer Performance Testing of Geologic Formations Underlying Glenn-Colusa Irrigation District, Orland Artois Water District, and Orland Unit Water Users Association Service Areas, Glenn County, California*. White Paper. California State University, Chico.

Please note the attached map from the State Water Resources Control Board (2008) that highlights areas vulnerable to groundwater contamination throughout the state. A significant portion of both the areas of origin and the receiving areas are highlighted. When the potential for serious health and safety impacts exists, NEPA and CEQA require that this must be disclosed and analyzed.

29

iii. Surface Water Flows

The EIS/EIR asserts that, under the no action/no project alternative, “Surface water supplies would not change relative to existing conditions. Water users would continue to experience shortages under certain hydrologic conditions, requiring them to use supplemental water supplies.” (3.1-15.) It would be most helpful if the lead agencies would explain the geographic scope of this statement since the shortages could be experienced throughout the areas of origin, transmission, and delivery – as well as the entire State of California. The section continues with, “Under the No Action/No Project Alternative, some agricultural and urban water users may face potential shortages under dry and critical hydrologic conditions.” Again, to what geographic areas is the EIS/EIR referring? The final sentence in the section reads, “Impacts to surface water supplies would be the same as the existing conditions.” Without further elaboration or a reference that would further explain what exactly are the “existing conditions, mentioned” this is merely a conclusory assertion without the benefit of factual data. For example, existing conditions vary wildly in California weather patterns and agency allocations can as well. For example, in 2014 CVP Settlement Contractors were threatened with an unprecedented 40 percent allocation, which later became 75 percent when they cooperated with water transfers. Failing to disclose the wide range of natural and agency decisions that comprise the No Action/No Project alternative must be corrected and re-circulated in another draft EIS/EIR.

30

The EIS/EIR states that “[b]ecause of the interaction of surface flows and groundwater flows in riparian systems, including associated wetlands, enables faster recharge of groundwater, these systems are less likely to be impacted by groundwater drawdown as a result of the action alternatives;” therefore, “[t]hese systems are less likely to be impacted by groundwater drawdown as a result of the action alternatives.” (EIS/EIR 3.8-32.) This flawed assumption has been readily discredited by USGS:

31

There is more of an interaction between the water in lakes and rivers and groundwater than most people think. Some, and often a great deal, of the water flowing in rivers comes from seepage of groundwater into the streambed. Groundwater contributes to streams in most physiographic and climatic settings... Groundwater pumping can alter how water moves between an aquifer and a stream, lake, or wetland by either intercepting groundwater flow that discharges into the surface-water body under natural conditions, or by

increasing the rate of water movement from the surface-water body into an aquifer. A related effect of groundwater pumping is the lowering of groundwater levels below the depth that streamside or wetland vegetation needs to survive. The overall effect is a loss of riparian vegetation and wildlife habitat.²³

31

Lastly, the EIR/EIS presents the rivers and streams analyzed for impacts from the Proposed Action alternative with numerous omissions and conclusory remarks that are not supported. (3.8-49 – 3.8-51.) Examples include:

- *Table 3.8.3 Screening Evaluation Results for Smaller Streams in the Sacramento River Watershed for Detailed Vegetation and Wildlife Impact Analysis for the Proposed Action* fails to designate the counties of origin except for Deer and Mill creeks. Even readers familiar with the region need this basic information.
- Creeks with groundwater/surface water connections, but omitted from Tehama and Butte counties in Table 3.8.3 include, but are not limited to: Clear, Cottonwood, Battle, Singer, Pine, Zimmershed, Rock, Mud, and Big Chico.
- The modeling that is used to omit streams from analysis and to select and analyze other streams is completely inadequate to the task. Page D-3 has information about model resolution. It is normal to have five to ten nodes to resolve a feature of interest, but the nodal spacing is listed as ranging from 125 to 1000 meters, with stream node spacing around 500 meters (EIS/EIR p. D-3). This implies that spatial features smaller than about 2 kilometers cannot be resolved with this model. With the physical response of interest below the threshold of resolution even under the best of circumstances, then you have 100% margin of error, because the model cannot "see" that response.²⁴

32

iv. Surface Water Quality

The baseline water quality data presented in the EIS/EIR is insufficient to accomplish any meaningful understanding of existing water quality levels throughout the project area. The EIS/EIR fails to show where each affected water body is, or disclose its existing beneficial uses, or numeric water quality objectives. Data that are presented is scattered, inconsistent, incomplete, often severely out of date, and often misleading. Further, the EIS/EIR fails to explain exactly where much of the presented water quality data comes from – indeed, failing to explain exactly where the affected environment is at all.

33

Many waterways are left out of this section entirely. The biological and vegetation effects of the program are discussed elsewhere in the EIS/EIR, and show that most would be impacted by the proposed program, but these waterways are not discussed in the EIS/EIR water quality section. Diminished flows can affect water quality in a variety of way, for example, causing

34

²³ The USGS Water Science School. <http://ga.water.usgs.gov/edu/gwdepletion.html>

²⁴ Mish, p. 8. (Exhibit C)

higher temperatures, lower dissolved oxygen, or high sediment contamination or turbidity. Therefore, these affected waterways should be described and analyzed in the EIS/EIR water quality chapter.

34

In addition, the EIS/EIR only names the California Aqueduct, the Delta-Mendota Canal, and the San Luis Reservoir as affected waters within the buyer areas. Later, the EIS/EIR admits that increased irrigation in the buyers' areas may adversely impact stream water quality, but none of these rivers, streams, creeks, or any other potentially affected waterway of any kind, are described in the buyer project areas. (EIS/EIR 3.2-26.)

35

The EIS/EIR also fails to meaningfully describe the existing water quality in the affected environment. The EIS/EIR repeatedly misleads the public and decision-makers regarding the baseline conditions of waters within the project area by labeling them as "generally high quality." For example, the EIS/EIR states that "certain segments of the Sacramento River contain several constituents of concern, including Chlordane, dichlorodiphenyltrichloroethane, Dieldrin, mercury, polychlorinated biphenyls (PCBs), and unknown toxicity (see Table 3.2-1); however, the water quality in the Sacramento River is generally of high quality." What is the basis for this non-sequitur used here, and repeated throughout the existing environmental descriptions in the EIS/EIR? How do constituents of concern and unknown toxicity translate to generally high quality?

36

The remaining baseline information presented in the EIS/EIR contains significant gaps that preclude a meaningful understanding of the existing environmental conditions. In order to attempt to characterize the water quality in the affected environmental area, the EIS/EIR lists out beneficial uses, 303(d) impairments, and a variety of water quality monitoring data. The EIS/EIR presents almost no reference to existing numeric water quality objectives, and evaluation of potential breaches of those standards is therefore impossible.

Table 3.2-1 lists 303(d) impairments within the area of analysis. The table states the approximate mileage or acreage of the portion of each water body that is impaired, but fails to inform the public exactly where these stretches are located. For example, table 3.2-1 states that, within the Delta, approximately 43,614 acres are impaired for unknown toxicity, 20,819 acres are impaired for electrical conductivity, and 8,398 acres are impaired for PCBs; but without knowing which acres within the Delta this table describes, it is impossible to know whether transfer water will affect those particular areas. This problem repeats for all impairments listed in table 3.2-1.

37

The baseline environmental condition of the Delta is poorly described. The EIS/EIR states that:

[e]xisting water quality constituents of concern in the Delta can be categorized broadly as metals, pesticides, nutrient enrichment and associated eutrophication, constituents associated with suspended sediments and turbidity, salinity, bromide, and organic

38

carbon. Salinity is a water quality constituent that is of specific concern and is described below.

(EIS/EIR at 3.2-21.) The EIS/EIR provides no further information about “metals, pesticides, nutrient enrichment and associated eutrophication, constituents associated with suspended sediments and turbidity.” These contaminants are each the focus of intensive regulation and controversy, and could cause significant adverse impacts if contaminated surface waters are transferred, but no meaningful baseline data of existing conditions is provided to facilitate an evaluation of the effects of the incremental changes caused by the proposed program.

38

The EIS/EIR provides scattered and essentially useless monitoring data to attempt to describe the existing water quality conditions in the program area. First, the EIS/EIR is unclear exactly what year or years it uses to constitute the baseline environmental conditions. Then, Tables 3.2-4 through 3.2-20 provide data from 1980 through 2014. Some tables average data, some use median data, some present isolated data, and none provide a comparison to existing numeric water quality objectives. Of all of the existing environmental baseline data provided, only table 3.2-15 provides any data regarding contamination caused by metals in the water column, and only for Lake Natoma from April to September of 2008. As a result, any contamination relating to any metals in any transfer water is essentially ignored by the EIS/EIR. Moreover, the scattershot data provided in the EIS/EIR does not provide the public with any information about the actual water quality of transfer water that may be used in any future project.

39

Table 3.2-21 presents mean data from “selected” monitoring stations throughout the Delta. The EIS/EIR states that “[s]ampling period varies, depending on location and constituent, but generally is between 2006-2012.” (EIS/EIR 3.2-22.) EIS/EIR readers simply have no way to know what these data actually represent. Columns are labeled “mean TDS,” “mean electrical conductivity,” and “mean chloride, dissolved.” Are these data averaged for the approximate period of 2006-2012? Were any data excluded? The EIS/EIR lists these monitoring stations, but doesn’t explain where each is actually located, which should be mapped for ease of reference. Nor does the EIS/EIR state what the applicable water quality objective is at each monitoring point for each parameter; nor how often these water quality objectives were breached.

40

Figure 3.2-2 presents the monthly median chloride concentrations at selected monitoring sites, and misleadingly states that these median concentrations do not exceed the secondary MCL for chloride of 250 mg/L; but that comparison is irrelevant as the Bay-Delta Plan sets water quality objectives for chloride at 250 mg/day, not monthly mean.

41

Figures 3.2-3 through 3.2-5 show average electrical conductivity at selected monitoring stations, but the EIS/EIR fails to state the relevant water quality standard against which to compare these data, and fails to report the frequency and magnitude of exceedances, which

42

are numerous and great. When do exceedances occur, and how can the proposed program avoid transferring water from or into waterways with elevated EC?

42

The EIS/EIR fails to provide any discussion or analysis of how SWRCB Decision 1641 would be implemented. The EIS/EIR states that Decision 1641 “requires Response Plans for water quality and water levels to protect diverters in the south Delta that may affect the opportunity to export transfers.” (EIS/EIR at 2-32.) Later, the EIS/EIR adds that Decision 1641 “require[s] that the Central Valley Project (CVP) and State Water Project (SWP) be operated to protect water quality, and that DWR and/or Reclamation ensure that the flow dependent water quality objectives are met in the Delta (SWRCB 2000).” (EIS/EIR 3.2-10.) Nowhere does the EIS/EIR actually identify what these requirements entail, nor analyze when they would or would not be met by any portion of the proposed program. D-1641 is among the most critical of water quality regulations controlling the proposed program, and the EIS/EIR must provide significantly more analysis of how it would propose to comply with these State Water Board standards. As discussed, below, compliance with D-1641 standards is far from certain.

43

Similarly, the EIS/EIR notes that “DWR has developed acceptance criteria to govern the water quality of non-Project water that may be conveyed through the California Aqueduct. These criteria dictate that a pump-in entity of any non-project water program must demonstrate that the water is of consistent, predictable, and acceptable quality prior to pumping the local groundwater into the SWP.” (EIS/EIR at 3.2-10.) Again, however, the EIS/EIR fails to explain what these criteria require, and fails to provide any discussion of whether, when, or how these criteria could be met for each transfer contemplated by the program. This lack of information and analysis is insufficient to support informed public and agency environmental decision-making.

44

IV. The EIS/EIR Fails to Evaluate Inconsistency with Applicable Laws, Plans, and Policies.

a. State Water Policies.

The EIS/EIR should fully disclose the consolidated places of use for DWR and the Bureau, and what criteria might be applied for greater flexibility claimed for the consolidated place of use necessary for any given year's water transfer program, and what project alternatives could avoid this shift. Could the transfers be facilitated through transfer provisions of the Central Valley Project Improvement Act? Would the consolidation be a permanent or temporary request, and would the consolidation be limited to the duration of just the *2015-2024 Water Transfer Program*? How would the consolidated places of use permit amendments to the SWP and CVP permits relate to their joint point of diversion? Would simply having the joint point of diversion in place under D-1641 suffice for the purpose of the Project?

45

The EIS/EIR should better describe existing water right claims of sellers, buyers, the Bureau, and DWR. In response to inquiries from the Governor’s Delta Vision Task Force, the SWRCB

46

acknowledged that while average runoff in the Delta watershed between 1921 and 2003 was 29 million acre-feet annually, the 6,300 active water right permits issued by the SWRCB is approximately 245 million acre-feet²⁵ (pp. 2-3). In other words, **water rights on paper are 8.4 times greater than the real water in California's Central Valley rivers and streams diverted to supply those rights on an average annual basis.** And the SWRCB acknowledges that this 'water bubble' does not even take account of the higher priority rights to divert held by pre-1914 appropriators and riparian water right holders (*Id.* p. 1). More current research reveals that the average annual unimpaired flow in the Sacramento River basin is 21.6 MAF, but the consumptive use claims are an extraordinary 120.6 MAF – 5.6 times more claims than there is available water.²⁶ Informing the public about water rights claims would necessarily show that buyers and the Agencies clearly possess junior water rights as compared with those of many willing sellers. Full disclosure of these disparate water right claims and their priority is needed to help explain the actions and motivations of buyers and sellers in the *2015-2024 Water Transfer Program*. Otherwise the public and decision makers have insufficient information on which to support and make informed choices.

46

To establish a proper legal context for these water rights, the EIS/EIR should also describe more extensively the applicable California Water Code sections about the treatment of water rights involved in water transfers.

Like federal financial regulators failing to regulate the shadow financial sector, subprime mortgages, Ponzi schemes, and toxic assets of our recent economic history, the state of California has been derelict in its management of scarce water resources. As we mentioned above we are supplementing these comments on this matter of wasteful use and diversion of water by incorporating by reference and attaching the 2011 complaint to the State Water Resources Control Board of the California Water Impact Network the California Sportfishing Protection Alliance, and AquAlliance on public trust, waste and unreasonable use and method of diversion as additional evidence of a systemic failure of governance by the State Water Resources Control Board, the Department of Water Resources and the U.S. Bureau of Reclamation, filed with the Board on April 21, 2011. (Exhibit Q)

47

b. Public Trust Doctrine.

The State of California has the duty to protect the people's common heritage in streams, lakes, marshlands, and tidelands through the Public Trust Doctrine.²⁷ The Sacramento, Feather, and Yuba rivers and the Delta are common pool resources. DWR acknowledges this legal reality in

48

²⁵ SWRCB, 2008. Water Rights Within the Bay Delta Watershed (Exhibit P.)

²⁶ California Water Impact Network, AquAlliance, and California Sportfishing Protection Alliance 2012. *Testimony on Water Availability Analysis for Trinity, Sacramento, and San Joaquin River Basins Tributary to the Bay-Delta Estuary.* (Exhibit Q)

²⁷ *National Audubon Society v. Superior Court* (1983) 33 Cal 3d, 419, 441.

its publication, *Water Transfer Approval: Assuring Responsible Transfers*.²⁸ The application of the Public Trust Doctrine requires an analysis of the public trust values of competing alternatives, as was directed by the State Water Board in the Mono Lake Case. Its applicability to alternatives for the water transfers planned from the Sacramento, Feather, and Yuba rivers and through the Delta, where species recovery, ecosystem restoration, recreation and navigation are pitted against damage from water exports, is exactly the kind of situation suited to a Public Trust analysis, which should be required by the 2015-2024 Water Transfer Program. The act of appropriating water—whether for a new use or for a new method of diversion or of use— is an acquisition of a property right from the waters of the state, an act that is therefore subject to regulation under the state’s public trust responsibilities. Groundwater pumping with adverse effects to public trust surface waters must also be considered.

48

c. Local General Plans and Ordinances.

The Draft EIS/EIR discusses only two county ordinances, the Colusa Ordinance No. 615 and Yolo Export Ordinance No. 1617, one agreement, the Water Forum Agreement in Sacramento County, and one conjunctive use program, the American River Basin Regional Conjunctive Use Program. Except for the brief discussion of the two ordinances, one agreement, and one conjunctive use program listed above, the Draft EIS/EIR doesn’t describe the requirements of local GMPs, ordinances, and agreements listed in Tables 3.3-1 (page 3.3-8) and Table 3-1 (page 27). Thus, the actual groundwater substitution transfer project permit requirements, restrictions, conditions, or exemptions required for each seller service area by the Bureau, DWR, and one or more County GMP or groundwater ordinance will apparently be determined at a future date.

49

Additional information is needed on what the local regulations require for exporting groundwater out of each seller’s groundwater basin. The Draft EIS/EIR needs to discuss how the local regulations ensure that the project complies with Water Code Sections 1220, 1745.10, 1810, 10750, 10753.7, 10920-10936, and 12924 (for more detailed discussion of these Water Codes see Draft EIS/EIR Section 3.3.1.2.2). Although the Draft EIS/EIR doesn’t document, compare or evaluate the requirements of all local agencies that have authority over groundwater substitution transfers in each seller service area, the Draft EIS/EIR concludes that the environmental impacts from groundwater substitution transfer pumping by each of the sellers will either be less than significant and cause no injury, or be mitigated to less than significant through mitigation measures WS-1, and GW-1 with its reliance on compliance with local regulations.

²⁸ California Department of Water Resources, *Water Transfer Approval: Assuring Responsible Transfers*, July 2012, page 3. Accessible online 16 February 2014 at http://www.water.ca.gov/watertransfers/docs/responsible_water_transfers_2012.pdf. In addition, the Delta Protection Act of 1959 also acknowledges this reality, California Water Code Sections 12200-12205. (Exhibit R)

As noted above, this conclusions is derived from information absent from the EIS/EIR and, even if there was information considered by the Lead Agencies, without any apparent analysis. Butte, Glenn, and Shasta counties represent counties with Sellers and all of them have the potential to be heavily impacted by activities in or adjacent to their jurisdictions. AquAlliance has examined their ordinances and found them insufficient to protect other users and the environment (Exhibits U, V, X). Sincere efforts at monitoring for groundwater levels and subsidence become meaningless if the monitoring infrastructure is scant and enforcement absent. The Butte County Department of Water and Resource Conservation also explains that local plans are simply not up to the task of managing a regional resource:

Each of the four counties that overlie the Lower Tuscan aquifer system has their own and separate regulatory structure relating to groundwater management. Tehama County, Colusa, and Butte Counties each have their own version of an export ordinance to protect the citizens from transfer-related third party impacts. Glenn County does not have an export ordinance because it relies on Basin Management Objectives (BMOs) to manage the groundwater resource, and subsequently to protect third parties from transfer related impacts. Recently, Butte County also adopted a BMO type of groundwater management ordinance. Butte County, Tehama County and several irrigation districts in each of the four counties have adopted AB3030 groundwater management plans. All of these groundwater management activities were initiated prior to recognizing that a regional aquifer system exists that extends over more than one county and that certain activities in one county could adversely impact another. Clearly the current ordinances, AB3030 plans, and local BMO activities, which were intended for localized groundwater management, are not well suited for management of a regional groundwater resource like that theorized of the Lower Tuscan aquifer system.²⁹

There is a possibility that a seller's groundwater substitution area of impact will occur in multiple local jurisdictions, which should results in project requirements coming from multiple local as well as state and federal agencies. The Draft EIS/EIR doesn't discuss the obstacles from cross jurisdictional impacts that are immense because groundwater basins cross county lines thereby eliminating authority. (*Id*) One obvious example is found with productions wells placed in Glenn County in the lower end of the Tuscan Aquifer Basin that may affect the up-gradient part of the aquifer in Butte and Tehama counties.

If the Project proceeds, each seller's project analysis should identify what future analyses, ordinances, project conditions, exemptions, monitoring and mitigation measures are required to ensure that each of the seller's project meets or exceed the goals of the Draft EIS/EIR.

V. The EIS/EIR Fails to Adequately Analyze Numerous Environmental Effects.

²⁹ Butte County Department of Water and Resource Conservation, *Needs Assessment Tuscan Aquifer Monitoring, Recharge, and Data Management Project*,.2007. (Exhibit S)

The EIS/EIR fails to include numerous required elements to support a meaningful analysis of the project's significant adverse impacts. First, the deficiencies in the incomplete and undefined project description, and incomplete description of existing environmental conditions, render any true impact analysis, or hard look at the project effects, impossible. *See, e.g., Santiago County Water Dist. v. County of Orange* (1981) 118 Cal.App.3d 818; *San Joaquin Raptor Rescue Ctr. v. County of Merced* (2007) 149 Cal.App.4th 645. Even the analysis provided, however, employs unsupported and inapplicable standards of significance. (CEQA Guidelines § 15064(b); *see, e.g., Oakland Heritage Alliance v. City of Oakland* (2011) 195 Cal.App.4th 884, 896; *Protect the Historic Amador Waterways v. Amador Water Agency* (2004) 116 Cal.App.4th 1099, 1111). The EIS/EIR fails to completely analyze the project's significant adverse impacts, and fails to support its conclusions with substantial evidence, failing to characterize the project effects in the proper context and intensity. (*Id.*; 40 C.F.R. § 1508.27(a); *City of Maywood v. Los Angeles Unified School Dist.* (2012) 208 Cal.App.4th 362, 391; *Laurel Heights Improvement Association v. Regents of Univ. of Cal.* (1988) 47 Cal.3d 376, 393; *Madera Oversight Coalition, Inc. v. County of Madera* (2011) 199 Cal.App.4th 48, 102 ("whether an EIR is sufficient as an informational document is a question of law subject to independent review by the courts."))

52

As discussed, below, and in the expert reports submitted by *Custis, EcoNorthwest, Cannon, and Mish* on behalf of AquAlliance, the EIS/EIR fails to comport with these standards.

a. Surface Water Flows.

The EIS/EIR fails to adequately analyze changes to all surface water flows as a result of the proposed project. While the EIS/EIR presents some level of streamflow drawdown analysis in its vegetation and biological resources section, that analysis is not taken into consideration with respect to affects to other water supply rights. This raises the specter of injury to senior water rights holders, and the EIS/EIR fails to provide sufficient information regarding where such rights are held and in what amounts, and where proposed transfers may interfere.

53

Streamflow depletion in the EIS/EIR is evaluated through modeling, but a closer look at the models employed shows significant omissions. First, because the rate of stream depletion is scaled to pumping rate and because the model documentation doesn't indicate the pumping locations, rates, volumes, times or durations that produced the pumped volumes shown in Figure 3.3-25, or the stream depletions shown in Figures B-5 and B-6 in Appendix B, it appears that the SACFEM2013 modeling did not simulate the maximum rate of stream depletion for the proposed 10-year project. Second, the available Delta export capacity was determined from CalSim II model results using only conditions through WY 2003, which fails to account for

54

55

current conditions, climate change conditions, and future conditions. (EIS/EIR 3.7-18.) The adequacy of CalSIM II has also been called into question.³⁰

55

In addition, the Bay-Delta Conservation Plan establishes flow limits for the Delta that the EIS/EIR fails to consider. Instead, the EIS/EIR states that the proposed projects could decrease outflows by 0.3 percent in winter and spring, and provides a bare conclusion that this impact is less than significant. (EIS/EIR 3.2-39.) Just this year the Bureau of Reclamation and DWR requested a Temporary Urgency Change from the SWRCB, a modification to Delta flow objectives that were not being met, and D-1641 standards, in order to attempt to manage species protection.³¹

56

The EIS/EIR attempts to consider changes in available supplies for project participants, but fails to review what other water rights holders may be affected by diminished flows. This is especially important given the EIS/EIR's conclusion that transfers would be most needed in times of critical shortage.

57

The EIS/EIR also fails to disclose changes in flows as a result of tailwater and ag drainage, which could lead to significant streamflow impacts.

58

b. Water Quality.

- i. The EIS/EIR improperly excludes substantial amounts of water from any meaningful impact evaluation.

The EIS/EIR fails to provide any evidence to support its proposition that "if the change in flow is less than ten cubic feet per second (cfs), it is assumed that there would be no water quality impacts as this is within the error margins of the model." (EIS/EIR 3.2-27.) First, the margin of error of the model has no bearing on actual water quality. Second, NPDES permits regularly regulate flows of less than 10 cfs. According to USGS, 10 cfs equals 6.46 million gallons per day (MGD). The EIS/EIR's assumption that a change in reservoir elevation of less than 1,000 acre feet could not possibly have significant impacts to water quality is similarly baseless. (EIS/EIR 3.2-27.) This amounts to approximately 325,800 gallons of water, more than enough to result in a noticeable difference in water quality. The Federal Clean Water Act is a strict liability statute providing no de minimis exceptions. By way of comparison, the City of Galt Wastewater Treatment Plant maintains flows at 4.5 MGD (NPDES Permit No. CA0081434), the City of Colusa Wastewater Treatment Plant maintains flows of approximately 0.7 MGD (NPDES Permit No. CA0078999), and each of these facilities has been assessed penalties for effluent exceedances by the Regional Water Board in recent years. The EIS/EIR's conclusion that flows equivalent to entire municipal wastewater treatment plants have no ability to compromise water quality standards is simply wrong.

59

³⁰ Close, A., et al, 2003. A Strategic Review of CALSIM II and its Use for Water Planning, Management, and Operations in Central California (Exhibit T)

³¹ Letter from Mark W. Cowin to Tom Howard, April 9, 2014 (Exhibit U)

Similarly, the EIS/EIR provides the bare conclusion that:

CVP and SWP reservoirs within the Seller Service Area would experience only small changes in storage, which would not be of sufficient magnitude and frequency to result in substantive changes to water quality. Any small changes to water quality would not adversely affect designated beneficial uses, violate existing water quality standards, or substantially degrade water quality. Consequently, potential effects on reservoir water quality would be less than significant.

60

(EIS/EIR 3.2-31.) The EIS/EIR simply provides no evidence or analysis in making this conclusion.

Lastly, the EIS/EIR provides no actual analysis of potential impacts to San Luis Reservoir as a result of lowering water levels in response to transfers. The EIS/EIR admits that “storage under the Proposed Action would be less than the No Action/No Project Alternative for all months of the year,” and asserts that water levels would be lowered between 3%-6% as a result of the Project. (EIS/EIR 3.2-41.) The EIS/EIR then presents the bare conclusion that “These small changes in storage are not sufficient to adversely affect designated beneficial uses, violate existing water quality standards, or substantially degrade water quality.” The EIS/EIR provides no basis for this determination, including no comparison of baseline environmental conditions to changes in contaminated runoff as a result of any particular water transfer.

61

- ii. The EIS/EIR fails to provide any information with which to evaluate impacts from idled crop fields, or farmlands in buyers’ areas.

The EIS/EIR assumes certain agricultural practices will occur at idle rice fields, when in reality, property owners would be free to re-purpose idled fields in countless and creative ways. (EIS/EIR 3-2.30.) For idled alfalfa, corn, or tomato cropland, the EIS/EIR assumes that property owners will put in place erosion control measures to conserve soil. While this may be a reasonable assumption for some farms, others, who may prefer to pursue multi-year water transfers, may not have an interest in investing in soil conservation. In addition, the EIS/EIR fails to provide analysis of the degree of effectiveness of soil conservation measures where no groundcover is in place. (EIS/EIR 3.2-29.) If proven to be effective, the EIS/EIR should require the Lead Agencies to condition water transfers on these necessary mitigation measures, and provide monitoring and reporting to ensure their continued implementation. We recommend that the Bureau and DWR require, at a minimum, that local governments select independent third-party monitors, who are funded by surcharges on Project transfers paid by the buyers, to oversee the monitoring that is proposed in lieu of Bureau and DWR staff, and that peer-reviewed methods for monitoring be required. If this is not done, the Project’s proposed monitoring and mitigation outline is insufficient and cannot justify the significant risk of adverse environmental impacts.

62

The EIS/EIR also states that increased erosion would not be of concern in Butte, Colusa, Glenn, Solano, Sutter, and Yolo counties, due to the prevalence of clay and clay loam soils. (EIS/EIR 3.2-29.) This bare conclusion does not provide any meaningful evaluation of the proposed program's impacts. Does the EIS/EIR really mean to assert that nowhere across six entire counties does soil erosion adversely impact water quality?

63

The EIS/EIR contradicts itself, stating:

In cases of crop shifting, farmers may alter the application of pesticides and other chemicals which negatively affect water quality if allowed to enter area waterways. Since crop shifting would only affect currently utilized farmland, a significant increase in agricultural constituents of concern is not expected.

64

(EIS/EIR 3.2-30.) Would applications be altered, or remain the same? The EIS/EIR says both. In truth, due to the programmatic nature of this EIS/EIR, although it is a "project" not a "programmatic" document, one cannot know. This level of impact must be evaluated on a project-by-project basis, yet the Lead Agencies assertion that this is a "project" level EIS/EIR precludes additional CEQA and NEPA review.

The EIS/EIR concludes that water quality impacts in the buyer area would be less than significant, but provides no evidence or assurances whatsoever regarding the ultimate use of the purchased water would be. (EIS/EIR 3.2-41.) The EIS/EIR then considers only impacts resulting from increased crop irrigation, acknowledging that "[i]f this water were used to irrigate drainage impaired lands, increased irrigation could cause water to accumulate in the shallow root zone and could leach pollutants into the groundwater and potentially drain into the neighboring surface water bodies." (EIS/EIR 3.2-41.) The EIS/EIR then dismisses this possibility, assuming that buyers would only use water for "prime or important farmlands." Missing from this section is any analysis of water quality. What does the EIS/EIR consider to be prime or important farm lands? Do all such actual farms exhibit the same water quality in irrigated runoff? The EIS/EIR provides no assurances its assumptions will be met, and moreover, fails to explain what its assumptions actually are.

65

The EIS/EIR then again relies on an improper ratio comparison of the amount of transfer water potentially used in buyer areas, to the total amount of all water used in the buyers' areas. The EIS/EIR adds:

The small incremental supply within the drainage-impaired service areas would not be sufficient to change drainage patterns or existing water quality, particularly given drainage management, water conservation actions and existing regulatory compliance efforts already implemented in that area.

66

(EIS/EIR 3.2-41.) Again, however, any comparison ratio of transferred water to other irrigation simply provides no analysis of what water quality impacts any individual transfer would have

after application on any individual farm. Moreover, if indeed a transfer is responding to a shortage, the transfer amount could actually constitute all or a majority of water usage for a particular site. Allusion to “existing regulatory compliance efforts” only suggests that regulatory compliance is not already maintained in each and every potential buyer farmland. There is no reasonable dispute that return flows from irrigated agriculture can often compromise water quality standards, but the EIS/EIR simply brushes this impact aside.

66

The EIS/EIR assumes that transfers may only occur during times of shortage (EIS/EIR 3.2-41), yet the proposed project itself is not so narrowly defined, and nothing in the Water Code limits transfers to circumstances where there has been a demonstrated shortfall in the buyer’s area. As a result of this open-ended project description, the true water quality impacts in the buyers’ areas are completely unknown.

67

- iii. The EIS/EIR ignores numerous potentially significant sources of contamination to surface waters.

The EIS/EIR describes the existing environmental conditions of most of the water bodies within the potential seller areas to be impaired for numerous contaminants; and also provides sampling and monitoring data to show that in-stream exceedances of water quality objectives regularly occur. Yet, the EIS/EIR fails to ever discuss the impact of moving contaminated water from one source to another. For example, where a seller’s water is listed as impaired for certain contaminants, any movement of that water to another waterbody will simply spread this impairment. The EIS/EIR provides no information with which to determine the actual water quality of the seller’s water for any particular transfer, nor any evaluation or monitoring to determine whether moving these contaminants from one water to another would harm beneficial uses or exceed receiving water limits. The EIS/EIR should provide a more particularized review of potential contaminants and their impacts under the proposed project. For example, the EIS/EIR does not analyze water quality impacts from boron, but the BDCP EIS/EIR states, “large-scale, out-of-basin water transfers have reduced the assimilative capacity of the river, thereby exacerbating the water quality issues associated with boron.” (BDCP EIS/EIR at 8-40.) Similarly, dissolved oxygen, among other forms of contamination, pose regular problems pursuant to D-1641. These potentially significant impacts must be disclosed for public and agency review.

68

What selenium and boron loads in Mud Slough and other tributaries to the San Joaquin River may be expected from application of this water to western San Joaquin Valley lands?

The EIS/EIR fails to disclose whether changes in specific conductivity as a result of the program would result in significant impacts to water quality. First, as noted above, the EIS/EIR presents scattered baseline data, much of which appears to show ongoing EC exceedances, but the EIS/EIR fails to disclose what Bay-Delta EC standards are, and the frequency and magnitude of baseline exceedances. Against this backdrop, the EIS/EIR then admits that program transfers would increase EC by as much as 4.3 percent. (EIS/EIR 3.2-39.) The EIS/EIR fails to disclose

69

whether these regular EC increases would exacerbate baseline violation conditions. In addition, the EIS/EIR only presents analysis for one monitoring location, whereas the Bay-Delta plan contains EC limits for over a dozen monitoring locations.

69

The EIS/EIR fails to disclose the extent to which program transfers could harm water quality by moving the "X2" location through the Delta. D-1641 specifies that, from February through June, the location of X2 must be west of Collinsville and additionally must be west of Chipps Island or Port Chicago for a certain number of days each month, depending on the previous month's Eight River Index. D-1641 specifies that compliance with the X2 standard may occur in one of three ways: (1) the daily average EC at the compliance point is less than or equal to 2.64 millimhos/cm; (2) the 14-day average EC is less than or equal to 2.64 millimhos/cm; or (3) the 3-day average Delta outflow is greater than or equal to the corresponding minimum outflow.

70

The EIS/EIR relies on an improper ratio approach to its impact evaluation of increased EC concentrations in the Delta Mendota Canal as a result of San Joaquin River diversions. (EIS/EIR 3.2-40.) The EIS/EIR admits that EC in the canal would increase as a result of these diversions, but fails to disclose by how much, or against what existing environmental conditions. Instead, the EIS/EIR compares the transfer amount, approximately 250 cfs, to the total capacity of the canal, about 4,000 cfs, to conclude that EC changes would not be significant. A comparison of the transfer amount to the total canal capacity simply provides no analysis of or information about EC concentrations.

71

The EIS/EIR fails to meaningfully evaluate potentially significant impacts to surface water quality as a result of groundwater substitution. First, the EIS/EIR provides an improper and misleading comparison, stating that

The amount of groundwater substituted for surface water under the Proposed Action would be relatively small compared to the amount of surface water used to irrigate agricultural fields in the Seller Service Area. Groundwater would mix with surface water in agricultural drainages prior to irrigation return flow reaching the rivers. Constituents of concern that may be present in the groundwater could enter the surface water as a result of mixing with irrigation return flows. Any constituents of concern, however, would be greatly diluted when mixed with the existing surface waters applied because a much higher volume of surface water is used for irrigation purposes in the Seller Service Area. Additionally, groundwater quality in the area is generally good and sufficient for municipal, agricultural, domestic, and industrial uses.

72

(EIS/EIR at 3.2-21.) The EIS/EIR's threshold of significance asks whether any water quality objective will be violated, and this must be measured at each discharge point. In turn, any farm that substitutes surface water irrigation for groundwater irrigation must be evaluated against this threshold. The EIS/EIR fails to provide any evidence to support its conclusion that the dilution of the groundwater runoff into surface waters would avoid any significant water quality

impacts. On one hand the EIS/EIR asserts that groundwater is of good quality, and on the other hand, asserts that the overall quality would improve as it is mixed with surface water irrigation runoff: *which* source provides the better water quality in this arrangement? It is widely recognized that irrigated agricultural return flows can transport significant contaminants to receiving water bodies. In addition, the EIS/EIR simply assumes that contaminated groundwater would not be pumped and applied to agricultural lands, despite the fact that groundwater extractions may mobilize PCE, TCE, and nitrate plumes under the City of Chico,³² and fails to disclose the existence of all hazardous waste plumes in the area of origin where groundwater substitution may occur. The assertion that “groundwater is generally good” throughout 6-10 counties is insufficient to provide any meaningful information against which to evaluate any particular transfer.

72

For “non-Project” reservoirs, the EIS/EIR provides one piece of additional information: modeling projections showing various rates of drawdown in table 3.2-24. The EIS/EIR then concludes that because water quality in these reservoirs is generally good, the reductions would not result in any significant water quality impacts. Again, the EIS/EIR provides no evidence or analysis to support this bare conclusion. Nor does the EIS/EIR present the beneficial uses of Collins Lake, nor Dry Creek, downstream of Collins Lake (see Table 3.2-2). The EIS/EIR does note that Lake McClure, Hell Hole Reservoir, and Camp Far West Reservoir maintain beneficial uses for cold water habitat and wildlife habitat, but fails to evaluate whether these beneficial uses would be impacted. Dissolved oxygen rates will decrease with lower water levels, and any sediment-based contaminant concentration, will increase. And the fact that drawdowns increase in already-critical years only heightens the water quality concerns.

73

The EIS/EIR repeatedly relies on dilution as the solution, with no actual analysis or receiving water assimilative capacity, and no regulatory authority. It is well-established law that a discharger may receive a mixing zone of dilution to determine compliance with receiving water objectives if and only if the permittee has conducted a mixing zone study, submitted to a Regional Board or the State Board for approval. (See, e.g., *Waterkeepers N. Cal. v. AG Indus. Mfg.*, 2005 U.S. Dist. LEXIS 43006 [“A dilution credit is a limited regulatory exception that must be preceded by a site specific mixing zone study”]; Water Quality Standards; Establishment of Numeric Criteria for Priority Toxic Pollutants for the State of California, 65 Fed. Reg. 31682 (May 18, 2000), 31701 [“All waters . . . are subject to the criteria promulgated today. Such criteria will need to be attained at the end of the discharge pipe, unless the State authorizes a mixing zone.”]) The EIS/EIR entirely ignores Clean Water Act requirements for obtaining dilution credits, and, with no supporting evidence whatsoever, effectively and illegally grants dilution credits across the board. (See, EIS/EIR 3.2-31, 3.2-35, 3.2-36, 3.2-42, 3.2-59). For each instance in which the EIR/EIS wishes to apply dilution credit to its determination of whether water quality impacts will be significant, it must perform – with the approval of the State or Regional

74

³² http://www.ci.chico.ca.us/capital_project_services/NitrateArea2NPh3U1-3.asp

Water Board – a mixing zone study considering the impacted waterbody and the specific types and quantities of the proposed pollutant discharge(s). Short of that, each time the EIS/EIR relies on dilution as the solution, it fails to analyze whether any contaminant in any waterbody in any amount could protect beneficial uses or exceed receiving water standards. The more Project water goes to south-of-Delta agricultural users than to urban users, the higher would be their groundwater levels, the more contaminated the groundwater would be in the western San Joaquin Valley and the more the San Joaquin River would be negatively affected from contaminated seepage and tailwater by operation of the Project.

74

c. Groundwater Resources.

The modeling efforts presented by the EIS/EIR fail to accurately capture the project's groundwater impacts. First, the SACFEM2013 simulations didn't evaluate the impacts of pumping the maximum annual amount proposed for each of the 10 years of the project. Second, because the groundwater modeling effort didn't include the most recent 11 years record, it appears to have missed simulating the most recent periods of groundwater substitution transfer pumping and other groundwater impacting events, such as recent changes in groundwater elevations and groundwater storage (DWR, 2014b), and the reduced recharge due to the recent periods of drought. Without taking the hydrologic conditions during the recent 11 years into account, the results of the SACFEM2013 model simulation may not accurately depict the current conditions or predict the effects from the proposed groundwater substitution transfer pumping during the next 10 years.

75

The Lead Agencies are making gross assumptions about the number, size, and behavior of all the surface water resources in the state, just to be able to coerce those assumptions into data that fits into the SACFEM2013 model. The assumptions are driving the modeling instead of the model (and science) driving accurate results. Appendix D is full of inaccurate statements and clear indications that this model is deficient. For example, it's advertised as a 3D model, but it's actually a collection of linked 2D models, and those are driven not by science, but by assumptions, e.g., the model can't calculate the location of the phreatic surface: it relies on assumptions and observations for that data, and that makes the model incapable of prediction.³³

76

The Draft EIS/EIR should provide the time-drawdown and distance-drawdown hydraulic characteristics for each groundwater substitution transfer well so that non-participant well owners can estimate and evaluate the potential impacts to their well(s) from well interference due to the pumping the groundwater substitution transfer well(s). This analysis is not present in the EIS/EIR.

77

³³ Mish (Exhibit C) pp. 3 and 4).

The EIS/EIR wrongly assumes that stream depletion impacts from pumping occur only downstream from the point on the stream closest to the pumping well.³⁴ Any monitoring of the effects of groundwater substitution pumping on surface or ground water levels, rates and areas of stream depletion, fisheries, vegetation and wildlife impacts, and other critical structures needs to cover a much wider area than what is needed for a direct surface water diversion.

78

The EIS/EIR doesn't compare the known groundwater quality problem areas with the SACFEM2013 simulated drawdowns to demonstrate that the proposed projects won't draw in or expand the areas of known poor water quality. The EIS/EIR analysis doesn't appear to consider the impacts to private well owners. Pumping done as part of the groundwater substitution transfer may cause water quality impacts from geochemical changes resulting from a lowering the water table below historic elevations, which exposes aquifer material to different redox conditions and can alter the mixing ratio of different quality aquifer zones being pumped. Changes in groundwater level can also alter the direction and/or rate of movement of contaminated groundwater plumes both horizontally and vertically, which may expose non-participating wells to contaminants they would not otherwise encounter.

79

The EIS/EIR fails to evaluate any changes in the rate and direction of inter-basin groundwater flow. Inter-basin groundwater flow may become a hidden long-term impact that increases the time needed for recovery of groundwater levels from groundwater substitution transfer pumping, and can extend the impact from groundwater substitution transfer pumping to areas outside of the groundwater substitution transfer seller's boundary.

80

Finally, the EIS/EIR should evaluate how Project transfers could add to the already high water table in the western San Joaquin Valley? Impacts from a higher water table could include increased groundwater contamination, lower flood resistance, greater erosion, and loss of suitability of certain parcels to particular land uses.

81

d. The SACFEM 2013 and CALSIM II Models are Inadequate.

The comments herein are based largely on the attached work of Dr. Custis (Exhibit A) and Dr. Mish (Exhibit C), and we request specific responses to these attached works. The EIR/EIS fails to accurately estimate environmental effects likely to occur during water transfers. The SACFEM2013 model used to predict groundwater resources is flawed by being based on poor technology that is simply not up to the task of accurate large-scale modeling.

82

The SACFEM2013 model is only partially predictive, in that key aquifer responses are entered as input data instead of being computed as predictive quantities. The model requires considerable data manipulation to be used, and these manipulations are necessarily subject to interpretation. The model description in the EIR/EIS presents no validation results that can be used to provide basic quality-assurance for the analyses used in the EIR/EIS. The model is not

³⁴ Custis (Exhibit A)

predictive in many important responses (as mentioned above), so its results are a reflection of past data (e.g., streamflows, phreatic surface location, etc.) instead of providing a predictive capability for future events. As described in previous sections, both the model and the input data contain gross over-simplifications that compromise the ability to provide accurate estimates of real-world responses of water resources. On page 19 of Appendix B, the reader is promised that model uncertainty will be described in Appendix D, but that promise is never delivered. This lack of any formal measure of uncertainty is not an unimportant detail, as it is impossible to provide accurate estimates of margin of error without some formal treatment of uncertainty. Any physical response asserted by the model's results has a margin of error of 100% if that response involves spatial scales smaller than a kilometer or more.

82

The EIR/EIS makes little connection between groundwater extraction process modeled by SACFEM2013 and the all-too-real potential for surface subsidence, and the attendant irreversible loss of aquifer capacity. The problem is especially important during drought years, when groundwater substitution is most likely to occur. In a drought, the aquifer already entrains less groundwater than normal, so that additional stresses due to pumping are visited upon the aquifer skeleton. This is exactly the conditions required to cause loss of capacity and the risk of subsidence. Yet the EIR/EIS makes scant mention of these all-too-real problems, and no serious modeling effort is presented in the EIR/EIS to assess the risk of such environmental degradation.

83

In contrast to the shortcomings of the model, the Bureau/DWR's DTIPWT seeks information on interactions between groundwater pumping and groundwater/surface water supplies at various increments of less than one and two miles. (DTIPWT at Appendix B.) Where the EIS/EIR fails to provide information at a level of detail required by BOR and DWR to determine whether significant impacts to water supplies may occur, the EIS/EIR fails to provide information needed to support a full analysis of groundwater and surface water impacts, and fails to support its conclusions with evidence.

84

CalSim II is a highly complex simulation model of a complex system that requires significant expertise to run and understand. Consequently, only a few individuals concentrated in the Department of Water Resources, U.S. Bureau of Reclamation and several consulting firms understand the details and capabilities of the model. State Water Resources Control Board (SWRCB) staff cannot run the model. To the extent CalSim II is relied upon, the EIR/EIS must be transparent and clearly explain and justify all assumptions made in model runs. It must explicitly state when findings are based on post processing and when findings are based on direct model results. And results must include error bars to account for uncertainty and margin of safety.

85

As an optimization model, CalSim II is hardwired to assume perfect supply and perfect demand. The notion of perfect supply is predicated on the erroneous assumption that groundwater can always be obtained to augment upstream supply. However, the state and federal projects have

86

no right to groundwater in the unadjudicated Sacramento River basin. Operating under this assumption risks causing impacts to ecosystems dependent upon groundwater basins in the areas of origin. The notion of perfect demand is also problematic, as it cannot account for the myriad of flow, habitat and water quality requirements mandated by state and federal statutes. Perfect demand assumes water deliveries constrained only by environmental constraints included in the code. In other words, CalSim II never truly measures environmental harm beyond simply projecting how to maximize deliveries without violating the incorporated environmental constraints. As a monthly time-step model, CalSim II cannot determine weekly, daily or instantaneous effects; i.e., it cannot accurately simulate actual instantaneous or even weekly flows. It follows that CalSim II cannot identify real-time impacts to objectives or requirements. Indeed, DWR admits, "CalSim II modeling should only be used in 'comparative mode,' that is when comparing the results of alternate CalSim II model runs and that 'great caution should be taken when comparing actual data to modeled data."³⁵

86

The Department of Civil Engineering University of California at Davis conducted a comprehensive survey of members of California's technical and policy-oriented water management community regarding the use and development of CalSim II in California. Detailed interviews were conducted with individuals from California's water community, including staff from both DWR and USBR (the agencies that created, own, and manage the model) and individuals affiliated with consulting firms, water districts, environmental groups, and universities.

The results of the survey, which was funded by the CalFed Science Program and peer-reviewed, should serve as a cautionary note to those who make decisions based on CalSim II. The report cites that in interviewing DWR and USBR management and modeling technical staff: "*Many interviewees acknowledge that using CALSIM II in a predictive manner is risky and/or inappropriate, but without any other agency-supported alternative they have no other option.*"

87

The report continues that: "All users agree that CalSim II needs better documentation of the model, data, inputs, and results. CalSim II is data-driven, and so it requires numerous input files, many of which lack documentation," and "There is considerable debate about the current and desirable state of CalSim II's calibration and verification," and "Its representation of the SWP and CVP includes many simplifications that raise concerns regarding the accuracy of results." "The model's inability to capture within-month variations sometimes results in overestimates of the volume of water the projects can export from the Sacramento- San Joaquin Bay-Delta and makes it seem easier to meet environmental standards than it is in real operations." The study concluded by observing, "CalSim II is being used, and will continue to be used, for many other types of analyses for which it may be ill-suited, including in absolute mode."

³⁵ Answering Brief for Plaintiff-Intervenor-Appellee California Department of Water Resources, Appeal from the United States District Court for the Eastern District of California, No. 1:09-cv-407, Case: 11-15871, 02/10/2012, ID: 8065113, page 15

In sum, the relied-upon models fail to accurately characterize the existing and future environment, fail to assess project-related impacts at a level of detailed required for the EIS/EIR, and fail to support the EIS/EIR's conclusions regarding significance of impacts.

87

e. Seismicity.

The EIS/EIR reasoning that because the projects don't involve new construction or modification of existing structures that there are no potential seismic impacts from the activity undertaken during the transfers is incorrect. The project area has numerous existing structures that could be affected by the groundwater substitution transfer pumping, specifically settlement induced by subsidence. Although the seismicity in the Sacramento Valley is lower than many areas of California, it's not insignificant. There is a potential for the groundwater substitution transfer projects to increase the impacts of seismic shaking because of subsidence causing additional stress on existing structures.

88

The EIS/EIR fails to inform the public through any analysis of the potential effects excessive groundwater pumping in the seller area may have on the numerous known earthquake faults running through and about the north Delta area, and into other regions of Northern California. As recently detailed in a paper published by a well-respected British scientific journal, "[u]plift and seismicity driven by groundwater depletion in central California," excessive pumping of groundwater from the Central Valley might be affecting the frequency of earthquakes along the San Andreas Fault, and raising the elevation of local mountain belts. The research posits that removal of groundwater lessens the weight and pressure on the Earth's upper crust, which allows the crust to move upward, releasing pressure on faults, and rendering them closure to failure. Long-Term Water Transfer Agreements have impacted the volume of groundwater extracted as farmers are able to pump and then forego surface water in exchange for money. The drought has exacerbated the need for water in buyer areas, and depleted the natural regeneration of groundwater supply due to the scarcity of rain.

89

Detailed analyses of this seismicity and focal mechanisms indicate that active geologic structures include blind thrust and reverse faults and associated folds (e.g., Dunnigan Hills) within the Coast Ranges-Sierran Block ("CRSB") boundary zone on the western margin of the Sacramento Valley, the Willows and Corning faults in the valley interior, and reactivated portions of the Foothill fault system. Other possibly seismogenic faults include the Chico monocline fault in the Sierran foothills and the Paskenta, Elder Creek and Cold Fork faults on the northwestern margin of the Sacramento Valley.³⁶

f. Climate Change.

³⁶ http://archives.datapages.com/data/pacific/data/088/088001/5_ps0880005.htm (Custis, Exhibit A)

The gross omissions and errors within the climate change analysis of the EIS/EIR fail to accurately describe the existing climatological conditions into which the project may be approved, fail to accurately describe the diminution of water and natural resources over recent and future years as a result of climate change, fail to integrate these changing circumstances into any future baseline or cumulative conditions, and fail to completely analyze or support the EIS/EIR conclusions regarding the project's potentially significant impacts.

90

i. The EIS/EIR Completely Fails to Incorporate Any Climate Change Information into its Analysis.

The EIS/EIR provides no analysis whatsoever of the extent to which climate change will affect the EIS/EIR assumptions regarding water supply, water quality, groundwater, or fisheries. Despite providing an overview of extant literature and study, all agreeing that California temperatures have been, are, and will continue to be rising, the entire EIS/EIR analysis of climate change interactions with the proposed project states:

As described in the Section 3.6.1.3, changes to annual temperatures, extreme heat, precipitation, sea level rise and storm surge, and snowpack and streamflow are expected to occur in the future because of climate change. Because of the short-term duration of the Proposed Action (10 years), any effects of climate change on this alternative are expected to be minimal. Impacts to the Proposed Action from climate change would be less than significant.

91

(EIS/EIR 3.6-21 to 3.6-22; similarly, the EIS/EIR Fisheries chapter at 3.7-23 states: "Future climate change is not expected to alter conditions in any reservoir under the No Action/No Project Alternative because there will be limited climate change predicted over the ten year project duration (see Section 3.6, Climate Change/Greenhouse Gas).")

First, this "analysis" seriously misstates extant science by claiming that climate change impacts "are expected to occur in the future." The effects of climate change are affecting California's water resources at present, and have been for years. A 2007 DWR fact sheet, for example, states that "[c]limate change is already impacting California's water resources."³⁷ A more recent 2013 report issued by the California Office of Environmental Health Hazard Assessment states that "[m]any indicators reveal already discernible impacts of climate change, highlighting the urgency for the state, local government and others to undertake mitigation and adaptation strategies."³⁸ The report states that:

³⁷ <http://www.water.ca.gov/climatechange/docs/062807factsheet.pdf> (Exhibit AA)

³⁸ <http://oehha.ca.gov/multimedia/epic/pdf/ClimateChangeIndicatorsSummaryAugust2013.pdf> (Exhibit BB)

Climate is a key factor affecting snow, ice and frozen ground, streams, rivers, lakes and the ocean. Regional climate change, particularly warming temperatures, have affected these natural physical systems.

From October to March, snow accumulates in the Sierra Nevada. This snowpack stores much of the year's water supply. Spring warming releases the water as snowmelt runoff. Over the past century, spring runoff to the Sacramento River has decreased by 9 percent. Lower runoff volumes from April to July may indicate: (1) warmer winters, during which precipitation falls as rain instead of snow; and (2) earlier springtime warming.

Glaciers are important indicators of climate change. They respond to the combination of winter snowfall and spring and summer temperatures. Like spring snowmelt, the melting of glaciers supplies water to sustain flora and fauna during the warmer months. Glacier shrinkage results in earlier peak runoff and drier summer conditions—changes with ecological impacts—and contributes to sea level rise.

With warming temperatures over the past century, the surface area of glaciers in the Sierra Nevada has been decreasing. Losses have ranged from 20 to 70 percent.

...

Over the last century, sea levels have risen by an average of 7 inches along the California coast.

...

Lake waters have been warming at Lake Tahoe, Lake Almanor, Clear Lake and Mono Lake since the 1990s. Changes in water temperature can alter the chemical, physical and biological characteristics of a lake, leading to changes in the composition and abundance of organisms that inhabit it.

...

Snow-water content—the amount of water stored in the snowpack—has declined in the northern Sierra Nevada and increased in the southern Sierra Nevada, likely reflecting differences in precipitation patterns.

Reduced runoff means less water to meet the state's domestic, agricultural, hydroelectric power generation, recreation and other needs. Cold water fish habitat, alpine forest growth and wildfire conditions are also impacted.

In addition, climate change threatens to reduce the size of cold water pools in upstream reservoirs and raise temperatures in upstream river reaches for Chinook, and climate change will reduce Delta outflows and cause X2 to migrate further east and upstream. (See, BDCP at 5.B-310, "Delta smelt may occur more frequently in the north Delta diversions area under future climate conditions if sea level rise [and reduced Sacramento River inflow below Freeport] induces movement of the spawning population farther upstream than is currently typical.")

91

92

And, the EIS/EIR “[f]igure 3.6-1 shows the climate change area of analysis,” excluding all of the Sierra Nevadas except those within Placer County, and excluding all of Sacramento County. (EIS/EIR 3.6-2.)

93

Instead of accounting for these factors in its environmental analysis, the EIS/EIR takes the obtuse approach of relying only on “mid-century” and year 2100 projections to cast climate change as a “long-term” and “future” problem. (See, e.g., EIS/EIR 3.6-10.) First, the U.S. Department of Interior and the California Resources Agency clearly possess better information regarding past, present, and on-going changes to water supplies as a result of climate change than presented in the EIS/EIR, and such information must be incorporated. Second, even the information presented could be more fully described, and where appropriate, extrapolated, to support any meaningful analysis. Presumably these studies and reports provide more than one or two future data points, and instead show curved projections over time. For example, the EIS/EIR states that “[i]n California, snow water equivalent (the amount of water held in a volume of snow) is projected to decrease by 16 percent by 2035, 34 percent by 2070, and 57 percent by 2099, as compared to measurements between 1971 and 2000.” (EIS/EIR 3.6-11.) Are these the only three data points provided by the study? Unless the EIS/EIR assumes that the entire percent decreases will be felt exclusively in years 2035, 2070, and 2099, these data should be extrapolated, as follows, to approximate the snow melt decrease over the project term:

94

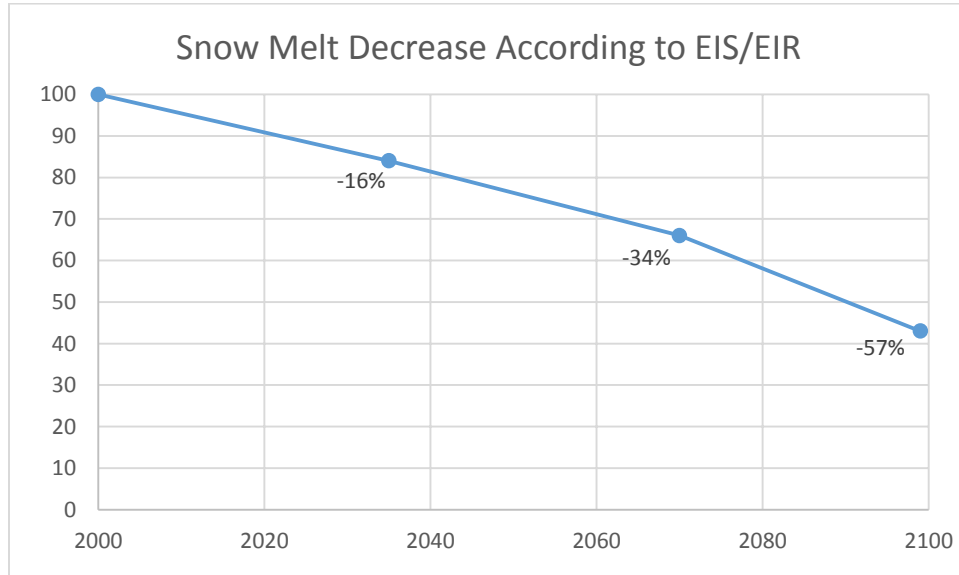

From this it is apparent that snow melt will decrease over the project term. This provides just one example, but the EIS/EIR itself should include meaningful analysis of climate change effects upon annual temperatures, extreme heat, precipitation, evaporation, sea level rise, storm surge, snowpack, groundwater, stream flow, riparian habitat, fisheries, and local economies over the life of the project.

Nine years ago, in 2005, then California Governor Arnold Schwarzenegger stated “[w]e know the science. We see the threat. And we know the time for action is now.”³⁹ Here, in contrast, the EIS/EIR says, let’s wait another ten years. This is simply unacceptable.

94

ii. The EIS/EIR Completely Ignores Increased GHG Emission in the Buyer Areas.

The EIS/EIR impact evaluation of increased GHG emissions in the buyer areas consists of a series of incomplete characterizations and unsupported conclusion. First, the EIS/EIR states: “Water transfers to agricultural users . . . could temporarily reduce the amount of land idled relative to the No Action/No Project Alternative.” (EIS/EIR 3.6-22.) This is in part true, but understates the impact, as there is no guarantee that the newly-supported land-uses would either be temporary, or agricultural. Second, the EIS/EIR states that “farmers may also pump less groundwater for irrigation, which would reduce emissions from use of diesel pumps.” This too is entirely speculative, and also contradicts the earlier implication that transfer water would only go to idled cropland. Third, the EIS/EIR summarily concludes that, “[t]he total amount of agricultural activity in the Buyer Service Area relative to GHG emissions would not likely change relative to existing conditions and the impact would be less than significant.” This again contradicts the EIS/EIR earlier statement that a water transfer could result in less idled cropland; and also defies logic and has no support in fact to suggest that increasing provision of a scarce resource would not induce some growth. At a bare minimum, the EIS/EIR should use its own estimated GHG reduction rates achieved as a result of newly idled cropland in the sellers’ service area as means of measuring the estimated GHG emission increases caused by activating idled cropland in the buyers’ service areas.

95

iii. The EIS/EIR Threshold of Significance for GHG Emissions is Inappropriate.

The EIS/EIR reviews nearly a dozen relevant, agency-adopted, thresholds of significant for GHG emissions, and chooses to select the single threshold that sits a full order of magnitude above all others. The chosen threshold is unsupported in fact or law, and creates internal contradiction within the EIS/EIR. The CEQA Guidelines state that:

96

A lead agency should consider the following factors, among others, when assessing the significance of impacts from greenhouse gas emissions on the environment:

...

Whether the project emissions exceed a threshold of significance that the lead agency determines applies to the project.

³⁹ United Nations World Environment Day Conference, June 1, 2005, San Francisco; see also, Executive Order S-3-05.

The extent to which the project complies with regulations or requirements adopted to implement a statewide, regional, or local plan for the reduction or mitigation of greenhouse gas emissions.

(CEQA Guidelines § 15064.4.) Numerous Air Districts within the affected area have established GHG thresholds of significance that the EIS/EIR improperly chooses not to apply. The EIS/EIR argues that these Air District thresholds are meant to apply to stationary sources, an exercise that “would be overly onerous and is not recommended.” (EIS/EIR 3.6-18.) This must be rejected. The EIS/EIR fails to provide any reason to believe that Air District regulations would not and should not be applied to activities occurring within each respective Air District. The CEQA Guidelines require the lead agency to use “a threshold of significance that the lead agency determines applies to the project;” here, the lead agency has not determined that the local Air District thresholds do not apply to the project activities; rather, it has determined that this evaluation would be too onerous. So instead, the EIS/EIR chooses to apply the threshold of significance adopted by the Antelope Valley Air District and the Mojave Desert Air District, each of which would clearly have latitude to adopt lax air quality thresholds owing to the lack of use intensity within each district. With (hopefully) no transfer water heading to the Mojave Desert, the lead agency has no basis to determine that the Mojave Desert Air District’s thresholds of significance “applies to the project.” The EIS/EIR also notes that the same threshold has been adopted by USEPA for Clean Air Act, Title V permits. But the Title V standard also applies to stationary sources, which the EIS/EIR says are inapplicable. Does any project element require a Title V permit? In short, the EIS/EIR fails to evaluate the project against any threshold of significance that was adopted either (1) for the benefit of an individual air district in which project activities would occur, or (2) for the benefit of regional or statewide GHG emission goals. The EIS/EIR’s unsupported grab of the most lax standard it could find, with no bearing on the project whatsoever, must be rejected.

96

g. Fisheries.

AquAlliance shares the widely held view that operation of the Delta export pumps is the major factor causing the Pelagic Organism Decline (“POD”) and in the deteriorating populations of fall-run Chinook salmon. In 2012, the State Water Resources Control Board received word in early December that the Fall Midwater Trawl surveys for September and October showed horrendous numbers for the target species. The indices for longfin smelt, splittal, and threadfin shad reveal the lowest in history.⁴⁰ Delta smelt, striped bass, and American shad numbers remain close to their lowest levels (*Id*). The 2013 indices were even worse and the 2014 indices are also abysmal (*Id*). Tom Cannon declared in June 2014 that water transfers have been and will remain devastating to Delta smelt during dry years.⁴¹ “In my opinion, the effect of Delta operations this summer [2014] of confining smelt to the Sacramento Deepwater ship channel

97

⁴⁰ <http://www.dfg.ca.gov/delta/data/fmwt/Indices/index.asp>. (Exhibit CC)

⁴¹ Cannon 2014. Declaration for Preliminary Injunction in AquAlliance and CSPA v. United State Bureau of Reclamation. (Exhibit DD)

upstream of Rio Vista due to adverse environmental conditions in the LSZ that will be exacerbated by the Transfers, both with and without relaxed outflow standards, with no evidence that they can emerge from the ship channel in the fall to produce another generation of smelt, is significant new information showing that the Transfers will have significant adverse impacts on Delta smelt.” Mr. Cannon’s October report observes that “habitat conditions have been very poor and the Delta smelt population is now much closer to extinction with the lowest summer index on record.”

As Mr. Cannon’s comments highlight, attached and fully incorporated as though stated in their entirety, herein, the EIS/EIR has inaccurately characterized the existing environment, including the assumption that delta smelt are not found in the Delta in the summer transfer season, when in fact during dry and critical years when transfers would occur, most if not all delta smelt are found in the Delta; and fails to fully assess the significant and cumulative effects to listed species in multiyear droughts when listed fish are already under maximum stress, which effects could be avoided by limiting transfers in the second or later years of drought.

97

The *2015-2024 Water Transfer Program* would exacerbate pumping of fresh water from the Delta, which has already suffered from excessive pumping over the last 12 years. Pumped exports cause reverse flows to occur in Old and Middle Rivers and can result in entrainment of fish and other organisms in the pumps. Pumping can shrink the habitat for Delta smelt (*Hypomesus transpacificus*) as well, since less water flows out past Chipps Island through Suisun Bay, which Delta smelt often prefer.

The EIS/EIR should also evaluate whether Project effects could alter stream flows necessary to maintain compliance with California Fish and Game Code Section 5937. A recent study issued from the University of California, Davis, documents hundreds of dams failing to maintain these required flows.⁴² Both the timing and volumes of transfer water must be considered in conjunction with 5937 flows.

98

h. Vegetation and Wildlife.

i. The EIS/EIR reaches faulty conclusion for Project and cumulative impacts.

Section 3.8.5, *Potentially Significant Unavoidable Impacts*, declares that, “None of the alternatives would result in potentially significant unavoidable impacts on natural communities, wildlife, or special-status species.” Regarding cumulative biological impacts of the proposed Project (Alternative 2), the EIS/EIR concludes, “Long-term water transfers would not be cumulatively considerable with the other projects because each of the projects would have little or no impact flows [sic] in rivers and creeks in the Sacramento River watershed or the vegetation and wildlife resources that depend on them,” (p. 3.8-92). This is a conclusory

99

⁴² https://watershed.ucdavis.edu/files/biblio/BioScience-2014-Grantham-biosci_biu159.pdf. (Exhibit EE)

statement without supporting material to justify it, only modeling that has been demonstrated in our comments as extremely deficient.

The EIS/EIR actually discloses there are very likely many significant impacts from the proposed project on terrestrial and aquatic habitat and species. Examples from Chapter 3.8 include:

- “The lacustrine natural communities in the Seller Service Area that would be potentially impacted by the alternatives include the following reservoirs: Shasta, Oroville, New Bullards Bar, Camp Far West, Collins, Folsom, Hell Hole, French Meadows, and McClure,” (p. 3.8-10)
- “The potential impacts of groundwater substitution on natural communities in upland areas was considered potentially significant if it resulted in a consistent, sustained depletion of water levels that were accessible to overlying communities (groundwater depth under existing conditions was 15 feet or less). A sustained depletion would be considered to have occurred if the groundwater basin did not recharge from one year to the next,” (p. 3.8-33).
- “In addition to changing groundwater levels, groundwater substitution transfers could affect stream flows. As groundwater storage refills during and after a transfer, it could result in reduced availability of surface water in nearby streams and wetlands,” (p. 3.8-33).

99

It should also be noted that the 2008 U.S. Fish and Wildlife Service (USFWS) and 2009 National Marine Fisheries Service (NMFS) biological opinions did not evaluate potential impacts to in-stream flow due to water transfers involving groundwater substitution. How these potential impacts may adversely affect biological resources in the areas where groundwater pumping will occur, including listed species and their habitat, were also not included.⁴³ To reach the conclusion that the Project “would not be cumulatively considerable with the other projects” based only on modeling fails to provide the public with meaningful analysis of probable impacts.

100

ii. The 2015-2024 Water Transfer Program has potential adverse impacts for the giant garter snake, a threatened species.

As the Lead and Approving Agencies are well aware, the purpose of the ESA is to conserve the ecosystems on which endangered and threatened species depend and to conserve and recover those species so that they no longer require the protections of the Act. 16 U.S.C. § 1531(b), ESA § 2(b); 16 U.S.C. § 1532(3), ESA §3(3) (defining “conservation” as “the use of all methods and procedures which are necessary to bring any endangered species or threatened species to the point at which the measures provided pursuant to this chapter are no longer necessary”). “[T]he ESA was enacted not merely to forestall the extinction of species (i.e., promote species

101

⁴³ California Department of Fish and Game. 2013. COMMENTS ON THE DRAFT ENVIRONMENTAL ASSESSMENT (2013 DRAFT EA) AND FINDING OF NO SIGNIFICANT IMPACT (FONSI) FOR THE 2013 CENTRAL VALLEY PROJECT (CVP) WATER, p.4. (Exhibit FF)

survival), but to allow a species to recover to the point where it may be delisted.” *Gifford Pinchot Task Force v. U.S. Fish & Wildlife Service*, 378 F.3d 1059, 1069 (9th Cir. 2004). To ensure that the statutory purpose will be carried out, the ESA imposes both substantive and procedural requirements on all federal agencies to carry out programs for the conservation of listed species and to insure that their actions are not likely to jeopardize the continued existence of any listed species or result in the destruction or adverse modification of critical habitat. 16 U.S.C. § 1536. See *NRDC v. Houston*, 146 F.3d 1118, 1127 (9th Cir. 1998) (action agencies have an “affirmative duty” to ensure that their actions do not jeopardize listed species and “independent obligations” to ensure that proposed actions are not likely to adversely affect listed species). To accomplish this goal, agencies must consult with the Fish and Wildlife Service whenever their actions “may affect” a listed species. 16 U.S.C. § 1536(a)(2); 50 C.F.R. § 402.14(a). Section 7 consultation is required for “any action [that] may affect listed species or critical habitat.” 50 C.F.R. § 402.14. Agency “action” is defined in the ESA’s implementing regulations to “mean all activities or programs of any kind authorized, funded, or carried out, in whole or in part, by Federal agencies in the United States.” 50 C.F.R. § 402.02.

101

The giant garter snake (“GGS”) is an endemic species to Central Valley California wetlands. (Draft Recovery Plan for the Giant Garter Snake (“DRP”) 1). The giant garter snake, as its name suggests, is the largest of all garter snake species, not to mention one of North America’s largest native snakes, reaching a length of up to 64 inches. Female GGS tend to be larger than males. GGS vary in color, especially depending on the region, from brown to olive, with white, yellow, or orange stripes. The GGS can be distinguished from the common garter snake by its lack of red markings and its larger size. GGS feed primarily on aquatic fish and specialize in ambushing small fish underwater, making aquatic habitat essential to their survival. Females give birth to live young from late July to early September, and brood size can vary from 10 to up to 46 young. Some studies have suggested that the GGS is sensitive to habitat change in that it prefers areas that are familiar and will not typically travel far distances.

102

If fallowing (idling) occurs, there will be potentially significant impacts to GGS and this is acknowledged on page 3.8-69: “Giant garter snakes have the potential to be affected by the Proposed Action through cropland idling/shifting and the effects of groundwater substitution on small streams and associated wetlands.” The Lead Agencies use language found in a 1997 Programmatic Biological Opinion (as well as the 1999 Draft Recovery Plan) to explain that GGS depend on more than rice fields in the Sacramento Valley. “The giant garter snake inhabits marshes, sloughs, ponds, small lakes, low gradient streams, other waterways and agricultural wetlands such as irrigation and drainage canals and rice fields, and the adjacent uplands. Essential habitat components consist of (1) adequate water during the snake’s active period, (early spring through mid-fall) to provide a prey base and cover; (2) emergent, herbaceous wetland vegetation, such as cattails and bulrushes, for escape cover and foraging habitat; (3)

upland habitat for basking, cover, and retreat sites; and (4) higher elevation uplands for cover and refuge from flood waters.”⁴⁴

Even with the explanation above, that clearly illustrates the importance of upland habitat to GGS, the EIS/EIR concludes that idling or shifting upland crops “[a]re not anticipated to affect giant garter snakes, as they do not provide suitable habitat for this species” (p. 3.8-69). The EIS/EIR is internally contradictory and fails to provide any evidence to support its conclusion that GGS will not be impacted by idling or shifting crops in upland areas. In support of the importance of upland acreage to GGS, a Biological Opinion for Gray Lodge found that, “Giant garter snakes also use burrows as refuge from extreme heat during their active period. The Biological Resources Division (BRD) of the USGS (Wylie et al_ 1997) has documented giant garter snakes using burrows in the summer as much as 165 feet (50. meters) away from the marsh edge. Overwintering snakes have been documented using burrows as far as 820 feet (250 meters) from the edge of marsh habitat,” (1998).⁴⁵

102

More pertinent background information that is lacking in the EIS/EIR is found in the Bureau’s Biological Assessment for the 2009 DWB that disclosed that one GGS study in Colusa County revealed the “longest average movement distances of 0.62 miles, with the longest being 1.7 miles, for sixteen snakes in 2006, and an average of 0.32 miles, with the longest being 0.6 miles for eight snakes in 2007.” (BA at p.16) However, in response to droughts and other changes in water availability, the GGS has been known to travel up to 5 miles in only a few days, and the EIS/EIR should evaluate impacts to GGS survival and reproduction under such extreme conditions

As the EIS/EIR divulges, flooded rice fields, irrigation canals, streams, and wetlands in the Sacramento Valley can be used by the giant garter snake for foraging, cover and dispersal purposes. The Bureau’s 2009 and 2014 Biological Assessments acknowledge the failure of the Bureau and DWR to complete the Conservation Strategy that was a requirement of the 2004 Biological Opinion (BA at p. 19-20). Research was finally initiated “since 2009,” but is nowhere near the projected 10-year completion date. The unnecessary delay hasn’t daunted the agencies pursuit of transfers that affect GGS despite the absence of the following information that the U.S. Fish and Wildlife Service has explicitly required since the 1990s:

103

- GGS distribution and abundance.
- Ten years of baseline surveys in the Sacramento Valley
- Five years of rice land idling surveys in the Sacramento Valley Recovery Unit and the Mid-Valley Recovery Unit.

⁴⁴ Programmatic Consultation with the U.S. Army Corps of Engineers
404 Permitted Projects with Relatively Small Effects on the Giant Garter Snake within Butte, Colusa, Glenn, Fresno, Merced, Sacramento, San Joaquin, Solano, Stanislaus, Sutter and Yolo Counties, California

⁴⁵ http://www.usbr.gov/mp/nepa/documentShow.cfm?Doc_ID=15453

This Project and all North-to-South and North-to-North transfers should be delayed until the Bureau and DWR have completed the Conservation Strategy they have known about for at least a decade and a half.

103

The Bureau and DWR continue to allow an increase in acres fallowed (2013 *Draft Technical Information for Preparing Water Transfer Proposals* (“DTIPWTP”)) since the 2010/2011 *Water Transfer Program* first proposed to delete or modify other mitigation measures previously adopted as a result of the Environmental Water Account (“EWA”) EIR process. The EWA substantially reduced significant impacts for GGS, but without showing that they are infeasible, the Bureau and DWR proposed to delete the 160 acre maximum for “idled block sizes” for rice fields left fallow rather than flooded and to substitute for it a 320 acre maximum. (See 2003 Draft EWA EIS/EIR, p. 10-55; 2004 Final EWA EIS/EIR, Appendix B, p. 18, Conservation Measure # 4.) There was no evidence in 2010 to support this change nor has there been any provided to the present time. In light of the agencies failure to complete the required Conservation Strategy mentioned above and the data gathered in the Colusa County study, how can the EIS/EIR suggest (although it is not presented in the document, but in the agencies *Draft Technical Information for Preparing Water Transfer Proposals* papers) that doubling the fallowing acreage is in any way biologically defensible? The Lead and Approving Agencies additionally propose to delete the EWA mitigation measure excluding Yolo County east of Highway 113 from the areas where rice fields may be left fallow rather than flooded, except in three specific areas.⁴⁶ (See 2004 Final EWA EIS/EIR, Appendix B, p. 18, Conservation Measure # 2.) What is the biological justification for this change and where is it documented? What are the impacts from this change?

104

Deleting these mitigation measures required by the EWA approval would violate NEPA and CEQA’s requirements that govern whether, when, and how agencies may eliminate mitigation measures previously adopted under NEPA and CEQA.

Additionally, the 2010/2011 *Water Transfer Program* failed to include sufficient safeguards to protect the giant garter snake and its habitat. The EA for that two-year project concluded, “The frequency and magnitude of rice land idling would likely increase through implementation of water transfer programs in the future. Increased rice idling transfers could result in chronic adverse effects to giant garter snake and their habitats and may result in long-term degradation to snake populations in the lower Sacramento Valley. In order to avoid potentially significant adverse impacts for the snake, additional surveys should be conducted prior to any alteration in water regime or landscape,” (p. 3-110). To address this significant impact the Bureau proposed relying on the 2009 Drought Water Bank (“DWB”) Biological Opinion, which was a one-year BO. Both the expired 2009 BO and the 2014 BO highlighted the Bureau and DWR’s avoidance of

105

⁴⁶ USBR and DWR, 2013. *Draft Technical Information for Preparing Water Transfer Proposals*.

meeting federal and state laws stating, “This office has consulted with Reclamation, both informally and formally, seven times since 2000 on various forbearance agreements and proposed water transfers for which water is made available [“for delivery south of the delta” is omitted in 2014] by fallowing rice (and other crops) or substituting other crops for rice in the Sacramento Valley. Although transfers of this nature were anticipated in our biological opinion on the environmental Water Account, that program expired in 2007 and, to our knowledge, no water was ever made available to EWA from rice fallowing or rice substitution. The need to consult with such frequency on transfers involving water made available from rice fallowing or rice substitution suggests to us a need for programmatic environmental compliance documents, including a programmatic biological opinion that addresses the additive effects on giant garter snakes of repeated fallowing over time, and the long-term effects of potentially large fluctuations and reductions in the amount and distribution of rice habitat upon which giant garter snakes in the Sacramento Valley depend,” (p.1-2). And here we are in late 2014 still without that programmatic environmental compliance that is needed under the Endangered Species Act.

105

If the Project is or isn’t approved, we propose that the Lead and Approving Agencies commit to the following conservation recommendations from the 2014 Biological Opinion by changing the word “should” to “shall”:

1. Reclamation should [shall] assist the Service in implementing recovery actions identified in the Draft Recovery Plan for the Giant Garter Snake (U.S. Fish and Wildlife Service 1999) as well as the final plan if issued during the term of the proposed action.
2. Reclamation should [shall] work with the Service, Department of Water Resources, and water contractors to investigate the long-term response of giant garter snake individuals and local populations to annual fluctuations in habitat from fallowing rice fields.
3. Reclamation should [shall] support the research goals of the Giant Garter Snake Monitoring and Research Strategy for the Sacramento Valley proposed in the Project Description of this biological opinion.
4. Reclamation should [shall] work with the Service to create and restore additional stable perennial wetland habitat for giant garter snakes in the Sacramento Valley so that they are less vulnerable to market-driven fluctuations in rice production. The CVPIA (b)(1)other and CVPCP conservation grant programs would be appropriate for such work.

- iii. The EIS/EIR fails to accurately describe the uppermost acreage that could impact GGS.

Page 3.8-69 claims that the Proposed Action “[c]ould idle up to a maximum of approximately 51,573 acres of rice fields,” but the Lead and Approving Agencies are well aware that past

106

transfers have or could have fallowed much more acreage and that 20 percent is allowed per county under the *Draft Technical Information for Preparing Water Transfer Proposals* last written in 2013. Factual numbers for proposed water transfers that included fallowing and groundwater substitution in the last 25 years should be disclosed in a revised and re-circulated draft EIS/EIR. The companion data that should also be presented would disclose how much water was actually transferred each year by seller and delineated by acreage of land fallowed and/or groundwater pumped. This information should not only be disclosed in the EIS/EIR, but it should also be readily available on the Bureau's web site. In addition, the EIS/EIR should cease equivocating with usage of "could" and "approximately" and select and analyze a firm maximum acreage of idled land, which would provide the public with the ability to consider the impacts from a most significant impact scenario.

106

"In 1992, Congress passed the Central Valley Project Improvement Act (Act, or CVPIA), which amended previous authorizations of the California Central Valley Project (CVP) to include fish and wildlife protection, restoration, enhancement, and mitigation as project purposes having equal priority with power generation, and irrigation and domestic water uses." ⁴⁷ The *2015-2024 Water Transfer Program* fails to take seriously the equal priority for, "[f]ish and wildlife protection, restoration, enhancement, and mitigation."

i. Economics.

Our comments are based largely upon the *EcoNorthwest* report produced for AquAlliance, attached and fully incorporated as though stated in their entirety, herein. Once again, the lack of relevant baseline information and discrete project description thwarts any ability to effectively analyze the project, and the lack of any market analysis of water prices, and prices for agricultural commodities, relegates the EIS/EIR to unsupported conclusions about the likely future frequency and amounts of water transfers and their environmental and economic consequences. The EIS/EIR further relies on obsolete data for certain key variables and ignores other relevant data and information. For example, the analysis assumes a price for water that bears no resemblance to the current reality. Growers and water sellers and buyers react to changing prices and market conditions, but the EIS/EIR is silent on these forces and how they would influence water transfers.

107

The EIS/EIR underestimates negative impacts on the regional economy in the sellers' area, acknowledging that negative economic impacts would be worse if water transfers happen over consecutive years, but estimating impacts only for single-year transfers, ignoring the data on the frequency of recent consecutive-year transfers.

108

As discussed, below, the EIS/EIR's inadequate evaluation and avoidance of subsidence will result in additional unaccounted-for economic costs. Injured third parties would bear the costs

109

⁴⁷ U.S. Department of Interior. *10 Year of Progress: Central Valley Project Improvement Act 1993-2002*. <http://www.waterrights.ca.gov/baydelta/docs/exhibits/SLDM-EXH-03B.pdf> (Exhibit GG)

of bringing to the sellers' attention harm caused by groundwater pumping, and the ability of parties to resolve disputes with compensation is speculative. The EIS/EIR is silent on these and other ripple cost effects of subsidence.

109

The EIS/EIR ignores the environmental externalities and economic subsidies that water transfers support. The EIS/EIR lists Westlands Water District as one of the CVP contractors expressing interest in purchasing transfer water. The environmental externalities caused by agricultural production in Westlands WD are well documented, as are the economic subsidies that support this production. To the extent that the water transfers at issue in the EIS/EIR facilitate agricultural production in Westlands WD, they also contribute to the environmental externalities and economic subsidies of that production, but the EIS/EIR is silent on these environmental and economic consequences of the water transfers.

110

j. Cultural Resources.⁴⁸

The EIS/EIR fails to adequately provide evidence that water transfers, which draw down reservoir surface elevations at Central Valley Project (CVP) and State Water Project (SWP) reservoirs beyond historically low levels, could not potentially adversely affect cultural resources. The EIS/EIR states that the potential of adverse impacts to cultural resources does exist:

3.13.2.4 Alternative 2: Full Range of Transfers (Proposed Action)

Transfers that draw down reservoir surface elevations at CVP and SWP reservoirs beyond historically low levels could affect cultural resources. The Proposed Action would affect reservoir elevation in CVP and SWP reservoirs and reservoirs participating in stored reservoir water transfers. Water transfers have the potential to affect cultural resources, if transfers result in changing operations beyond the No Action/No Project Alternative. Reservoir surface water elevation changes could expose previously inundated cultural resources to vandalism and/or increased wave action and erosion (p. 3.13-15).

111

This passage states that the Long Range Water Transfers undertaking may have the potential to affect cultural resources if the water transfers lowered reservoir elevations enough to expose cultural resources. The first step for analysing this would require conducting research for past studies and reports with site specific data for the CVP and SWP reservoirs. The EIS/EIR states:

3.13.1.3 Existing Conditions

This section describes existing conditions for cultural resources within the area of analysis. *All data regarding existing conditions were collected through an examination of archival and current literature pertinent to the area of analysis.* Because action

⁴⁸ Comments in this section are based on the work of Bill Helmer, prepared for AquAlliance on the 2014 Long-Term Water Transfers EIS/EIR

alternatives associated with the project do not involve physical construction-related impacts to cultural resources, no project specific cultural resource studies were conducted in preparation of this Environmental Impact Statement/Environmental Impact Report (EIS/EIR) (EIS/EIR, p. 3.13-13, emphasis added).

111

However, there are no references listed for all the data collected which were "pertinent to the area of analysis." Also, the EIS/EIR states on p. 3.13-15 cited above that the lowering of the reservoir water elevations due to water transfers may affect cultural resources. Obviously, such an impact does not need to "[i]nvolve physical construction-related impacts to cultural resources," so this rationale for not conducting specific cultural resource studies contradicts its own assertion.

Instead of conducting a cultural resources study which locates historic resources and traditional cultural properties (with the use of a contemporary Native American ethnological study), and then assesses the amount of project-related water elevation changes which may affect these resources, the EIS/EIR merely stated that their Transfer Operations Model was used to show that the project's "Impacts to cultural resources at Shasta, Oroville and Folsom reservoirs would be less than significant," (3.13-15, 3.13-16). A chart on page 13.3-15 shows that the proposed project is projected to decrease reservoir elevations at the "critical" level in September by 0.5 ft. at Shasta Reservoir, 2.4 ft. at Lake Oroville, and 1.5 ft. at Folsom Reservoir. (There is no source for this chart, and the reader has to guess that it may be from the Transfer Operations Model. The definitions of the various categories in the chart are also unexplained).

Based upon the findings shown on the chart, it is stated:

The reservoir surface elevation changes under the Proposed Action for these reservoirs would be within the normal operations and would not be expected to expose previously inundated cultural resources to vandalism or increased wave action and wind erosion. Impacts to cultural resources at Shasta, Oroville and Folsom reservoirs would be less than significant (p. 3.13-15).

112

However, there is no evidence to show that a project-related reservoir drop of 2.4 ft. at Lake Oroville will not uncover cultural resources documented in *The Archaeological and Historical Site Inventory at Lake Oroville, Butte County*,⁴⁹ and expose them "to vandalism or increased wave action and wind erosion," thus adversely affecting these resources. This study states that there are 223 archaeological and/or historic sites recorded in the water level fluctuation zone of Lake Oroville (p. 12). Where is the Cultural Study which shows that lowering Lake Oroville 2.4 ft. due to water transfers *will not* expose specific archaeological sites or traditional cultural properties?

⁴⁹ Prepared for the California Department of Water Resources by the Archaeological Research Center, Sacramento, and the Anthropological Studies Center, Rohnert Park, 2004. (Exhibit HH)

Without an inventory of the cultural resources which may be uncovered by the project-related drop in reservoir elevation for all the affected reservoirs, the numbers in the chart on page 13.3-15 mean nothing. The numbers in the chart provide no evidence that the project may or may not have an adverse effect on cultural resources. In contrast, substantial documentation of cultural resources in these areas exists.⁵⁰ The threat of potential project-related impacts to cultural resources triggers a Section 106 analysis of the project under the requirements of the National Historic Preservation Act, which "[r]equires Federal agencies to take into account the effects of their undertakings on historic properties" [36 CFR 800.1(a)].

112

Although the issue here is the raising of the Shasta Reservoir water levels, cultural impacts related to water levels at the Shasta Reservoir has been an ongoing issue for the Winnemem Wintu Tribe. The Winnemem Wintu Tribe and all tribes within the project area (Area of Potential Effects) need to be consulted by federal and state agencies. A project-specific cultural study under CEQA is also required under 15064.5. *Determining the Significance of Impacts to Archaeological and Historical Resources*. Consultation with federally recognized tribes and California Native American tribes is required for this project.

113

k. Air Quality.

The EIS/EIR fails to analyze the air quality impacts in all these regions, especially with regard to the Buyers Service Area. Moreover, Appendix F – Air Quality Emissions Calculations exclude portions of the Sellers Service Area in Placer and Merced Counties. Conversely, there was not data supplied in Appendix F concerning the air quality impacts from the water transfers that would affect the Bay Area AQMD counties (Alameda, Contra Costa, Santa Clara), a Monterey Bay Unified APCD county (San Benito) and San Joaquin APCD counties (San Joaquin, Stanislaus, Merced, Fresno and Kings). Consequently, air quality impacts in the Buyers and Sellers Service Areas are unanalyzed and the EIS/EIR conclusions are not supported by evidence.

114

The EIS/EIR attempts to classify which engines would be subject to the ATCM based on whether an agricultural engine is in an air district designated in attainment for particulate matter and ozone, and is more than a half mile away from any residential area, school or hospital (aka

115

⁵⁰ Folsom Reservoir: <http://online.wsj.com/articles/SB10001424052702304419104579322631095468744>
Lake Oroville-
<http://www.latimes.com/local/la-me-lake-oroville-artifacts-20140707-story.html#page=1> (Exhibit II)
Shasta Reservoir
<http://www.winnememwintu.us/2014/09/09/press-release-dam-the-indians-anyway-winnememwar-dance-at-shasta-dam/> (Exhibit JJ)

sensitive receptors). (See p. 3.5-14). The EIS/EIR claims that the engines in Colusa, Glenn, Shasta and Tehama (part of Sellers Service Area) are exempt from the ATCM. However, 17 CCCR 93115.3 exempts in-use stationary diesel agricultural emissions not only based on the engines being remote, but all also “provided owners or operators of such engines comply with the registration requirements of section 93115.8, subdivisions (c) and (d), and the applicable recordkeeping and reporting requirement of section 93115.10,” which the EIS/EIR ignores. Furthermore, the EIS/EIR fails to present any data about the “tier” the subject agricultural diesel engines fall into. While the EIS/EIR identifies the tiers and concomitant requirements for replacement or repowering, it fails to provide any analysis or evidence evaluating whether the engines being used to pump water are operating within the permissible timeframes, depending on the tier designation.

115

The EIS/EIR analyzes the assessment methods based on existing emissions models from the regulation, diesel emissions factors from USEPA Compilation of Air Pollutant Emission Factors (for Natural gas fired reciprocating engines and gasoline/diesel industrial engines) and CARB Emission Inventory Documentation (for land preparation, harvest operations and windblown dust); and CARB size fractions for particulate matter. None of these references is directly on point to diesel powered water pumps and the emissions caused thereby. Moreover, the EIS/EIR provides absolutely no information as to why these models are appropriate to serve as the basis for thresholds of significance.

116

The analysis provided in the EIS/EIR is less than complete. Here the “Significance Criteria” were only established and considered for the “sellers in the area of analysis where potential air quality impacts from groundwater substitution and crop idling transfers could occur.” (See p. 3.5-25) But that is only half the equation. The unconsidered air quality impacts include what and how increased crop production and vehicle usage would affect the air quality in the Buyers Service Area. Data and evidence of those impacts were not even considered.

In establishing the significance criteria, the EIS/EIR utilized known thresholds of significance from the air districts in the Sellers Service Area that had published them. For the other districts in the Sellers Service Area, the EIS/EIR made the assumption that “[t]he threshold used to define a ‘major source’ in the [Clean Air Act] CAA (100 tons per year [tpy])” could be “used to evaluate significance.” (See p. 3.5-26). There are several flaws with this over broad application of the “major source” threshold. First, agricultural pumps and associated agricultural activity are not typically considered “major sources,” especially when compared to major industrial sources. Second, the application of the major source threshold runs counter to the legal requirement that “[u]pwind APCDs are required to establish and implement emission control programs commensurate with the extent of pollutant transport to downwind districts,” as announced as a requirement of the California Clean Air Act. (See p. 3.5-11). Finally, the 100 tpy threshold is wildly disproportionate to the limits set in nearby or adjoining air district and covering the same air basin. For example, the Butte AQMD considers significance thresholds for

117

NOx, ROG/VOCs and PM10 to be 137lbs/day (25 tpy); Feather River AQMD considers significance thresholds for NOx and VOCs to be 25lbs/day (4.5 tpy) and 80 lbs/day (14.6 tpy) for PM10; Tehama APCD considers significance thresholds for NOx, ROG/VOCs and PM10 to be 137 lbs/day (25 tpy); Shasta AQMD considers significance thresholds for NOx, ROG/VOCs and PM10 on two levels – Level “B” is 137 lbs/day (25 tpy) and Level “A” is 25lbs/day (4.5 tpy) and 80 lbs/day (14.6 tpy) for PM10; and Yolo AQMD considers significance thresholds for ROG/VOCs and NOx to be 54.8 lbs/day (10 tpy) and 80 lbs/day (14.6 tpy) for PM10. Clearly, there is a proportional relationship between these thresholds of significance. In contrast, the EIS/EIR, with substantial evidence to the contrary, assumes that the threshold of significance for those air districts who have not published a *CEQA Handbook* should be 100 tpy, or an increase by magnitudes of 4 to 20 times more than similarly situated Central Valley air districts.

117

“When considering a project’s impact on air quality, a lead agency should provide substantial evidence that supports its conclusion in an explicit, quantitative analysis whenever possible.” (See Guide to Air Quality Assessment in Sacramento County, Sacramento Metropolitan Air Quality Management District, 2009, Ch. 2, p. 2-6). Importantly, the EIS/EIR provides no basis, other than an assumption, as to why the major source threshold of significance from the CAA should be used or is appropriate for assessing the significance of the project impacts under CEQA or NEPA. The use of the CAA’s threshold of significance for major sources is erroneous as a matter of law. (See *Endangered Habitats League v. County of Orange* (2005) 131 Cal.App.4th 777, 793 (“The use of an erroneous legal standard [for the threshold of significance in an EIR] is a failure to proceed in the manner required by law that requires reversal.”)) Lead agencies must conduct their own fact-based analysis of the project impacts, regardless of whether the project complies with other regulatory standards. Here, the EIR/EIS uses the CAA threshold without any factual analysis on its own, in violation of CEQA. (*Protect the Historic Amador Waterways v. Amador Water Agency* (2004) 116 Cal.App.4th 1099, 1109; citing *CBE v. California Resources Agency* (2002) 103 Cal.App.4th 98, 114; accord *Mejia v. City of Los Angeles* (2005) 130 Cal.App.4th 322, 342 [“A threshold of significance is not conclusive . . . and does not relieve a public agency of the duty to consider the evidence under the fair argument standard.”].) This uncritical application of the CAA’s major source threshold of significance, especially in light of the similarly situated air district lower standards, represents a failure in the exercise of independent judgment in preparing the EIS/EIR.

VI. The EIS/EIR Fails to Adequately Analyze Numerous Cumulative Impacts.

The Ninth Circuit Court makes clear that NEPA mandates “a useful analysis of the cumulative impacts of past, present and future projects.” *Muckleshoot Indian Tribe v. U.S. Forest Service*, 177 F.3d 800, 810 (9th Cir. 1999). “Detail is required in describing the cumulative effects of a proposed action with other proposed actions.” *Id.* CEQA further states that assessment of the

118

project's incremental effects must be "viewed in connection with the effects of past projects, the effects of other current projects, and the effects of probable future projects." (CEQA Guidelines § 15065(a)(3).) "[A] cumulative impact consists of an impact which is created as a result of the combination of the project evaluated in the EIR together with other projects causing related impacts." (CEQA Guidelines § 15065(a)(3).)

An EIR must discuss significant cumulative impacts. CEQA Guidelines §15130(a). Cumulative impacts are defined as two or more individual effects which, when considered together, are considerable or which compound or increase other environmental impacts. CEQA Guidelines § 15355(a). "[I]ndividual effects may be changes resulting from a single project or a number of separate projects. CEQA Guidelines § 15355(a). A legally adequate cumulative impacts analysis views a particular project over time and in conjunction with other related past, present, and reasonably foreseeable future projects whose impacts might compound or interrelate with those of the project at hand. Cumulative impacts can result from individually minor but collectively significant projects taking place over a period of time. CEQA Guidelines § 15355(b). The cumulative impacts concept recognizes that "[t]he full environmental impact of a proposed . . . action cannot be gauged in a vacuum." *Whitman v. Board of Supervisors* (1979) 88 Cal. App. 3d 397, 408 (internal quotation omitted).

In assessing the significance of a project's impact, the Bureau must consider "[c]umulative actions, which when viewed with other proposed actions have cumulatively significant impacts and should therefore be discussed in the same impact statement." 40 C.F.R. §1508.25(a)(2). A "cumulative impact" includes "the impact on the environment which results from the incremental impact of the action when added to *other past, present and reasonably foreseeable future actions* regardless of what agency (Federal or non-Federal) or person undertakes such other actions." *Id.* §1508.7. The regulations warn that "[s]ignificance cannot be avoided by terming an action temporary or by breaking it down into small component parts." *Id.* §1508.27(b)(7).

An environmental impact statement should also consider "[c]onnected actions." *Id.* §1508.25(a)(1). Actions are connected where they "[a]re interdependent parts of a larger action and depend on the larger action for their justification." *Id.* §1508.25(a)(1)(iii). Further, an environmental impact statement should consider "[s]imilar actions, which when viewed together with other *reasonably foreseeable or proposed agency actions*, have similarities that provide a basis for evaluating their environmental consequences together, such as common timing or geography." *Id.* §1508.25(a)(3) (emphasis added).

As discussed, below, and in the expert reports submitted by *Custis, EcoNorthwest, Cannon, and Mish* on behalf of AquAlliance, the EIS/EIR fails to comport with these standards for cumulative impacts upon surface and groundwater supplies, vegetation, and biological resources; and, the

baseline and modeling data relied upon by the EIS/EIR that does not account for related transfer projects in the last 11 years.

118

a. Recent Past Transfers.

Because the groundwater modeling effort didn't include the most recent 11 years record (1970-2003), it appears to have missed simulating the most recent periods of groundwater substitution transfer pumping and other groundwater impacting events, such as recent changes in groundwater elevations and groundwater storage (DWR, 2014b), and the reduced recharge due to the recent periods of drought. Without taking the hydrologic conditions during the recent 11 years into account, the results of the SACS2013 model simulation may not accurately depict the current conditions or predict the effects from the proposed groundwater substitution transfer pumping during the next 10 years.

- f. In 2009, the Bureau approved a 1 year water transfer program under which a number of transfers were made. Regarding NEPA, the Bureau issued a FONSI based on an EA.
- g. In 2010, the Bureau approved a 2 year water transfer program (for 2010 and 2011). No actual transfers were made under this approval. Regarding NEPA, the Bureau again issued a FONSI based on an EA.
- h. The Bureau planned 2012 water transfers of 76,000 AF of CVP water all through groundwater substitution.⁵¹
- i. In 2013, the Bureau approved a 1 year water transfer program, again issuing a FONSI based on an EA. The EA incorporated by reference the environmental analysis in the 2010-2011 EA.
- j. The Bureau and SLDMWA's 2014 Water Transfer Program proposed transferring up to 91,313 AF under current hydrologic conditions and up to 195,126 under improved conditions. This was straight forward, however, when attempting to determine how much water may come from fallowing or groundwater substitution during two different time periods, April-June and July-September, the reader was left to guess.⁵²

119

⁵¹ USBR 2012. Memo to the Deputy Assistant Supervisor, Endangered Species Division, Fish and Wildlife Office, Sacramento, California regarding Section 7 Consultation.

⁵² The 2014 Water Transfer Program's EA/MND was deficient in presenting accurate transfer numbers and types of transfers. The numbers in the "totals" row of Table 2-2 presumably should add up to 91,313. Instead, they add up to 110, 789. The numbers in the "totals" row of Table 2-3 presumably should add up to 195,126. Instead, they add up to 249,997. Both Tables 2-2 and 2-3 have a footnote stating: "These totals cannot be added together. Agencies could make water available through groundwater substitution, cropland idling, or a combination of the two; however, they will not make the full quantity available through both methods. Table 2-1 reflects the total upper limit for each agency."

These closely related projects impact the same resources, are not accounted for in the environmental baseline, and must be considered as cumulative impacts.

119

b. Yuba Accord

The relationship between the Lead Agencies is not found in the EIS/EIR, but is illuminated in a 2013 Environmental Assessment. “The Lower Yuba River Accord (Yuba Accord) provides supplemental dry year water supplies to state and Federal water contractors under a Water Purchase Agreement between the Yuba County Water Agency and the California Department of Water Resources (DWR). Subsequent to the execution of the Yuba Accord Water Purchase Agreement, DWR and The San Luis & Delta- Mendota Water Authority (Authority) entered into an agreement for the supply and conveyance of Yuba Accord water, to benefit nine of the Authority’s member districts (Member Districts) that are SOD [south of Delta] CVP water service contractors.”⁵³

In a Fact Sheet produced by the Bureau, it provides some numerical context and more of DWR’s involvement by stating, “Under the Lower Yuba River Accord, up to 70,000 acre-feet can be purchased by SLDMWA members annually from DWR. This water must be conveyed through the federal and/or state pumping plants in coordination with Reclamation and DWR. Because of conveyance losses, the amount of Yuba Accord water delivered to SLDMWA members is reduced by approximately 25 percent to approximately 52,500 acre-feet. Although Reclamation is not a signatory to the Yuba Accord, water conveyed to CVP contractors is treated as if it were Project water.”⁵⁴ However, the Yuba County Water Agency (“YCWA”) may transfer up to 200,000 under Corrected Order WR 2008-0014 for Long-Term Transfer and, “In any year, up to 120,000 af of the potential 200,000 af transfer total may consist of groundwater substitution. (YCWA-1, Appendix B, p. B-97.)”⁵⁵

120

Potential cumulative impacts from the Project and the YCWA Long-Term Transfer Program from 2008 - 2025 are not disclosed or analyzed in the EIS/EIR. The *2015-2024 Water Transfer Program* could transfer up to 600,000 AF per year through the same period that the YCWA Long-Term Transfers are potentially sending 200,000 AF into and south of the Delta. How these two projects operate simultaneously could have a very significant impact on the environment and economy of the Feather River and Yuba River’s watersheds and counties as well as the Delta. The involvement of Browns Valley Irrigation District and Cordua Irrigation District in both long-term programs must also be considered. This must be analyzed and presented to the public in a revised draft EIS/EIR.

⁵³ Bureau of Reclamation, 2013. *Storage, Conveyance, or Exchange of Yuba Accord Water in Federal Facilities for South of Delta Central Valley Project Contractors*.

⁵⁴ Bureau of Reclamation, 2013. *Central Valley Project (CVP) Water Transfer Program Fact Sheet*.

⁵⁵ State Water Resources Control Board, 2008. ORDER WR 2008 - 0025

Also not available in the EIS/EIR is disclosure of any issues associated with the YCWA transfers that have usually been touted as a model of success. The YCWA transfers have encountered troubling trends for over a decade that, according to the draft Environmental Water Account (“EWA”) EIS/EIR, are mitigated by deepening domestic wells (2003 p. 6-81). While digging deeper wells is at least a response to an impact, it hardly serves as a proactive measure to avoid impacts. Additional information finds that it may take 3-4 years to recover from groundwater substitution in the south sub-basin⁵⁶ although YCWA’s own analysis fails to determine how much river water is sacrificed to achieve the multi-year recharge rate. None of this is found in the EIS/EIR. What is found in the EIS/EIR is that even the inadequate SACFEM2013 modeling reveals that it could take more than six years in the Cordua ID area to recover from multi-year transfer events, although recovery is not defined (pp, 3.3-69 to 3.3-70). This is a very significant impact that isn’t addressed individually or cumulatively.

121

c. BDCP

The EIS/EIR fails to include the Bay Delta Conservation Plan (“BDCP”) in the Cumulative Impacts section and in any analysis of the *2015-2024 Water Transfer Program*. Although we acknowledge that BDCP could not possibly be built during the 10-Year Water Transfer Program’s operation, the EIS/EIR misses the point that the *2015-2024 Water Transfer Program* is a prelude to what comes later with BDCP. This connection is entirely absent. If the Twin Tunnels (the facilities identified in “Conservation Measure 1”) are built as planned with the capacity to take 15,000 cubic feet per second (“cfs”) from the Sacramento River, they will have the capacity to drain almost two-thirds of the Sacramento River’s average annual flow of 23,490 cfs at Freeport⁵⁷ (north of the planned Twin Tunnels). As proposed, the Twin Tunnels will also increase water transfers when the infrastructure for the Project has capacity. This will occur during dry years when State Water Project (“SWP”) contractor allocations drop to 50 percent of Table A amounts or below or when Central Valley Project (“CVP”) agricultural allocations are 40 percent or below, or when both projects’ allocations are at or below these levels (EIS/EIR Chapter 5). With BDCP, North to South water transfers would be in demand and feasible.

122

Communication regarding assurances for BDCP indicates that the purchase of approximately 1.3 million acre-feet of water is being planned as a mechanism to move water into the Delta to make up for flows that would be removed from the Sacramento River by the BDCP tunnels.⁵⁸ There is only one place that this water can come from: the Sacramento Valley’s watersheds. It is well known that the San Joaquin River is so depleted that it will not have any capacity to contribute meaningfully to Delta flows. Additionally, the San Joaquin River doesn’t flow past the proposed north Delta diversions and neither does the Mokelumne River.

⁵⁶ 2012. *The Yuba Accord, GW Substitutions and the Yuba Basin*. Presentation to the Accord Technical Committee. (pp. 21, 22).

⁵⁷ USGS 2009. <http://wdr.water.usgs.gov/wy2009/pdfs/11447650.2009.pdf> Exhibit KK)

⁵⁸ Belin, Lety, 2013. E-mail regarding Summary of Assurances. February 25 (Department of Interior). (Exhibit LL)

As discussed above, the EIS/EIR also fails to reveal that the *2015-2024 Water Transfer Program* is part of many more programs, plans and projects to develop water transfers in the Sacramento Valley, to develop a “conjunctive” system for the region, and to place water districts in a position to integrate the groundwater into the state water supply. BDCP is one of those plans that the federal agencies, together with DWR, SLDMWA, water districts, and others have been pursuing and developing for many years.

123

d. Biggs-West Gridley

The *Biggs-West Gridley Water District Gray Lodge Wildlife Area Water Supply Project*, a Bureau project, is not mentioned anywhere in the Vegetation and Wildlife or Cumulative Impacts sections.⁵⁹ This water supply project is located in southern Butte County where Western Canal WD, Richvale ID, Biggs-West Gridley WD, and Butte Water District actively sell water on a regular basis, yet impacts to GGS from this project are not disclosed. This is a serious omission that must be remedied in a recirculated draft EIS/EIR.

124

e. Other Projects

Court settlement discussions between the Bureau and Westlands Water District over provisions of drainage service. Case # CV-F-88-634-LJO/DLB will further strain the already over allocated Central Valley Project with the following conditions:

- k. A permanent CVP contract for 890,000 acre-feet of water a year exempt from acreage limitations.
- l. Minimal land retirement consisting of 100,000 acres; the amount of land Westlands claims it has already retired (115,000 acres) will be credited to this final figure. Worse, the Obama administration has stated it will be satisfied with 100,000 acres of “permanent” land retirement.
- m. Forgiveness of nearly \$400 million owed by Westlands to the federal government for capital repayment of Central Valley Project debt.
- n. Five-Year Warren Act Contracts for Conveyance of Groundwater in the Tehama-Colusa and Corning Canals – Contract Years 2013 through 2017 (March 1, 2013, through February 28, 2018).

125

Additional projects with cumulative impacts upon groundwater and surface water resources affected by the proposed project:

- a. The DWR Dry Year Purchase Agreement for Yuba County Water Agency water transfers from 2015-2025 to SLDMWA.⁶⁰

126

⁵⁹ http://www.usbr.gov/mp/nepa/nepa_projdetails.cfm?Project_ID=15381

⁶⁰ SLDMWA Resolution # 2014 386

http://www.sldmwa.org/OHTDocs/pdf_documents/Meetings/Board/Prepacket/2014_1106_Board_PrePacket.pdf

- b. GCID's *Stony Creek Fan Aquifer Performance Testing Plan* to install seven production wells in 2009 to extract 26,530 AF of groundwater as an experiment that was subject to litigation due to GCID's use of CEQAs exemption for research.
- c. Installation of numerous production wells by the Sellers in this Project many with the use of public funds such as Butte Water District,⁶¹ GCID, Anderson Cottonwood Irrigation District,⁶² and Yuba County Water Authority⁶³ among others.

126

VII. The EIS/EIR Fails to Develop Legally Adequate Mitigation Measures.

CEQA requires that the lead agency consider and adopt feasible mitigation measures that could reduce a project's adverse impacts to less than significant levels. Pub. Resources Code §§ 21002, 21002.1(a), 21100(b)(3), 21151, 22081(a). An adequate environmental analysis in the EIS/EIR itself is a prerequisite to evaluating proper mitigation measures: this analysis cannot be deferred to the mitigation measure itself. *See, e.g., Vineyard Area Citizens for Responsible Growth v. City of Rancho Cordova* (2007) 40 Cal.4th 412. Moreover, mitigation measures must A mitigation measure is inadequate if it allows significant impacts to occur before the mitigation measure takes effect. *POET, LLC v. State Air Resources Board* (2013) 218 Cal.App.4th 681, 740. An agency may not propose a list of measures that are "nonexclusive, undefined, untested and of unknown efficacy." *Communities for a Better Environment v. City of Richmond* (2010) 184 Cal.App.4th 70, 95. Formulation of mitigation measure should generally not be deferred. CEQA Guidelines § 15126.4(a)(1)(B). If deferred, however, mitigation measure must offer precise measures, criteria, and performance standards for mitigation measures that have been evaluated as feasible in the EIR, and which can be compared to established thresholds of significance. *E.g., POET, LLC v. State Air Resources Board* (2013) 218 Cal.App.4th 681; *Preserve Wild Santee v. City of Santee* (2012) 210 Cal.App.4th 260; *Sacramento Old City Association v. City Council* (1991) 229 Cal.App.3d 1011; CEQA Guidelines § 15126.4(a)(1)(B); *Defend the Bay v. City of Irvine* (2004) 119 Cal.App.4th 1261, 1275. Economic compensation alone does not mitigate a significant environmental impact. *See* CEQA Guidelines § 15370; *Gray v. County of Madera* (2008) 167 Cal.App.4th 1099, 1122. Where the effectiveness of a mitigation measure is uncertain, the lead agency must conclude the impact will be significant. *Citizens for Open Govt. v. City of Lodi* (2012) 70 Cal.App.4th 296, 322; *Fairview Neighbors v. County of Ventura* (1999) 70

127

⁶¹ Prop 13. Ground water storage program: 2003-2004 Develop two production wells and a monitoring program to track changes in ground.

⁶² "The ACID Groundwater Production Element Project includes the installation of two groundwater wells to supplement existing district surface water and groundwater supplies."
http://www.usbr.gov/mp/nepa/nepa_projdetails.cfm?Project_ID=8081

⁶³ Prop 13. Ground water storage program 2000-2001: Install eight wells in the Yuba-South Basin to improve water supply reliability for in-basin needs and provide greater flexibility in the operation of the surface water management facilities. \$1,500,00;

Cal.App.4th 238, 242. An EIR must not only mitigate direct effects, but also must mitigate cumulative impacts. CEQA Guidelines § 15130(b)(3).

Under NEPA, “all relevant, reasonable mitigation measures that could improve the project are to be identified,” including those outside the agency’s jurisdiction,⁶⁴ and including those for adverse impacts determined to be less-than-significant (40 C.F.R. § 1502.16(h)).

As discussed, below, and in the expert reports submitted by *Custis*, *EcoNorthwest*, *Cannon*, and *Mish* on behalf of AquAlliance, the EIS/EIR fails to comport with these standards.

The EIS/EIR illegally defers the development of and commitment to feasible mitigation measures to reduce or avoid a whole host of potentially significant project impacts. The EIS/EIR relies on mitigation measures WS-1 and GW-1 to reduce or avoid significant project effects through the entire environmental review document, not just for surface and ground water supplies, but also for impacts to vegetation, subsidence, regional economics, . (3.7-26, 3.7-56, 3.10-37, 3.10-51.) Unfortunately, these mitigation measures fail all standards for CEQA compliance, deferring analysis of the impact in question to a future time, including no criteria or performance standards by which to evaluate success, and failing to demonstrate that the measures are feasible or sufficient.

But the precise relationship of these mitigation measures is unclear. For example, the EIS/EIR relies on GW-1 to mitigate impacts to vegetation and wildlife as a result of stream flow loss; why doesn’t the EIS/EIR consider the streamflow mitigation measure for this impact?

a. Streamflow Depletion.

WS-1 requires that a portion of transfer water be held back to offset streamflow depletion caused by groundwater substitution pumping, but fails to include critical information to ensure that any such mitigation measure could work. First, it is not clear that any transfer release and the groundwater substitution pumping would simultaneously occur, in real time. If groundwater pumping causes streamflow depletion at any time other than exactly when the transfer is made, then the transfer deduction amount will not avoid streamflow drawdown. And, indeed, it is well known that streamflow depletion can continue, directly and cumulatively, after the transfer activity ends. (E.g., figures B-4, B-5 and B-6 in Draft EIS/EIR Appendix B).

Next, the EIS/EIR fails to include any meaningful information to determine whether the applicable “streamflow depletion factor” to be applied to any single transfer project will mitigate significant impacts.

The EIS/EIR provides that “The exact percentage of the streamflow depletion factor will be assessed and determined on a regular basis by Reclamation and DWR, in consultation with buyers and sellers, based on the best technical information available at that time.” (EIS/EIR at

⁶⁴ <http://ceq.hss.doe.gov/nepa/regs/40/40p3.htm>

127

128

129

3.1-21.) More information is required. It is unclear whether WS-1 considers the cumulative volume of water pumped for each groundwater substitution transfers, or the instantaneous rate of stream depletion caused by the pumping. Any factor must be the outcome of numerous measured variables, such as the availability of water to capture, the rate and duration of recharge, the streambed sediment permeability, the duration of pumping, the distance between the well and stream, and others; but the EIS/EIR fails to provide any means of evaluating these various factors. How good must the “best technical information available at that time” be? What is the likelihood it will be available, what constraints does this face, and what requirements are in place to ensure that sufficient information is obtained? Why hasn’t this information been analyzed in the EIS/EIR? What roles do the buyers and sellers have in reaching this determination?

129

Moreover, the EIS/EIR fails to identify the threshold of significance below which significant impacts would not occur. WS-1 purports to avoid “legal injury,” but fails to define any threshold or criteria that will be applied in the performance of WS-1 to clearly determine when legal injury would ever occur.

b. Groundwater Overdraft.

The EIS/EIR illegally defers formulation and evaluation of mitigation measure GW-1 in much the same way as WS-1. In reliance on GW-1, the EIS/EIR goes so far as to defer the environmental impact analysis that should be provided now, as part of the EIS/EIR itself. Moreover, GW-1 fails to include clear performance standards, criteria, thresholds of significance, evaluation of feasibility, analysis of likelihood of success, and even facially permits significant impacts to occur. And importantly, GW-1 does not, in fact, reduce potentially significant impacts to less-than-significant levels, but rather, attempts to monitor for when significant effects occur, then purports to provide measures to slow the impact from worsening.

130

GW-1 begins by referencing the *DRAFT Technical Information for Preparing Water Transfer Proposals* (“DTIPWTP”)(Reclamation and DWR 2013) and Addendum (Reclamation and DWR 2014). First, it is worth noting that this document is in DRAFT form, as have all such previous iterations of the Technical Information for Preparing Water Transfer Proposals, leaving any guidance for a final mitigation measure uncertain. Second, the DTIPWTP itself requires a project-specific evaluation of then-existing groundwater and surface water conditions to determine potentially significant impacts to water supplies; but this is exactly the type of impact analysis that must occur now in the self-described project EIS/EIR before any consideration of mitigation measures is possible. Even still, the exact scope of future environmental review is unclear as well. “Potential sellers will be required to submit well data,” but the EIS/EIR does not explain what data or why. (EIS/EIR at 3.3-88.)

131

GW-1 next requires potential sellers “to complete and implement a monitoring program,” but a monitoring program itself cannot prevent significant impacts from occurring. “ The monitoring

132

program will incorporate a sufficient number of monitoring wells to accurately characterize groundwater levels and response in the area before, during, and after transfer pumping takes place.’ (EIS/EIR 3.3-88.) Again, this should be done now, for public review, to determine the significance of project impacts before the project is approved. Moreover, the EIS/EIR fails to provide any guidance on what constitutes “a sufficient number of monitoring wells.” GW-1 then requires monitoring data no less than on a monthly basis, but common sense suggests that significant groundwater pumping could occur in less than a month’s time. GW-1 requires that “Groundwater level monitoring will include measurements before, during and after transfer-related pumping,” but monitoring after transfer-related pumping can only show whether significant impacts *have* occurred; it cannot prevent them. Yet this is exactly what the EIS/EIR proposes: “The purpose of Mitigation Measure GW-1 is to monitor groundwater levels during transfers to avoid potential effects. If any effects occur despite the monitoring efforts, the mitigation plan will describe how to address those effects.” (EIS/EIR 3.3-91.) Hence, GW-1 only requires elements of the mitigation plan to kick in after monitoring shows significant impacts, which are extremely likely to occur given the fact that monitoring alone amounts to no mitigation or avoidance measure.

132

Even still, the proposed mitigation plans don’t mitigate significant impacts. The mitigation plan includes the following requirements: “Curtailement of pumping until natural recharge corrects the issue.” This, of course, could take years and is acknowledged in the EIS/EIR (p. 3.1-17 and 18), and really amounts to no mitigation of the significant impact at all. “Reimbursement for significant increases in pumping costs due to the additional groundwater pumping to support the transfer.” In what amount, at what time, as decided by who? Monetary compensation is not always sufficient to cover damages to business operations. “Curtailement of pumping until water levels raise above historic lows if non-reversible subsidence is detected (based on local data to identify elastic versus inelastic subsidence).” It does not follow that any water level above the *historic lows* avoids or offsets damage from non-reversible subsidence. -only admits that irreversible subsidence may occur. Finally, “[o]ther actions as appropriate” is so vague as to be meaningless. (EIS/EIR 3.3-90.)

133

The wholesale deferral of these mitigation measures is particularly confusing since the lead agencies should already have monitoring and mitigation plans and evaluation reports based on the requirements of the DTIPWTP for past groundwater substitution transfers, which likely were undertaken by some of the same sellers as the proposed 10-year transfer project. The Draft EIS/EIR should provide these existing Bureau approved monitoring programs and mitigation plans as examples of what level of technical specificity is required to meet the objectives of GW-1.

The DTIPWRP doesn’t add any additional monitoring or mitigation requirements for subsidence, stating that areas that are susceptible to land subsidence may require land surface elevation surveys, and that the Project Agencies will work with the water transfer proponent to develop a mutually agreed upon subsidence monitoring program. The monitoring locations in “strategic” locations are similarly deferred with no guiding criteria.

134

Lastly, groundwater quality monitoring only appears to be required after a transfer has begun, which again is too late to prevent any significant impact from occurring. (EIS/EIR 3.3-89.)

135

Mitigation measure GW-1 calls for stopping pumping after significant impacts are detected and then waiting for natural recovery of the water table. This might not be in time for groundwater dependent farms or riparian trees (cottonwoods & willows) to recover from the impact or could greatly extend the time to recovery. In the meantime, riparian-dependent wildlife including Swainson's hawks would be without nesting habitat, migration corridors, and foraging areas. The mitigation measure should require active restoration of important habitat such as riparian and wetland, not natural recovery. Recovery to an arbitrary water level is not necessarily the same as recovery of wildlife habitat and populations of sensitive species.

136

The water level monitoring in the mitigation measure should give explicit quantitative criteria for significant impact. Stating that a reduction in flow or GW level is "within natural variation" and therefore not significant is deceptive. The natural variation includes extreme cases and the project should not be allowed to add an additional increment to an already extreme condition. The extremes are supposed to be rare, not long-term and chronic. For example, Little Chico Creek may be essentially dry at times but it is not totally dry and that may be all that allows plants and animals to persist until wetter conditions return. If everything dies because the creek becomes totally dry due to the project, then it may never recover.

137

VIII. The EIS/EIR Fails to Analyze a Reasonable Range of Alternatives.

The EIS/EIR is required to evaluate and implement feasible project alternatives that would lessen or avoid the project's potentially significant impacts. Pub. Resources Code §§ 21002, 21002.1(a), 21100(b)(4), 21150; *Citizens of Goleta Valley v. Board of Supervisors* (1990) 52 Cal.3d 553, 564. This is true even if the EIS/EIR purports to reduce or avoid any or all environmental impacts to less than significant levels. *Laurel Heights Improvement Assn. v. Regents of Univ. of Cal.* (1988) 47 Cal.3d 376. Alternatives that lessen the project's environmental impacts must be considered even if they do not meet all project objectives. CEQA Guidelines § 15126.6(a)-(b); *Habitat & Watershed Caretakers v City of Santa Cruz* (2013) 213 Cal.App.4th 1277, 1302; *Center for Biological Diversity v. County of San Bernardino* (2010) 185 Cal.App.4th 866. Further, the EIS/EIR must contain an accurate no-project alternative against which to consider the project's impacts. CEQA Guidelines § 15126.6(e)(1); *Mira Mar Mobile Community v. City of Oceanside* (2004) 119 Cal.App.4th 477.

138

Under NEPA, the alternatives analysis constitutes "the heart of the environmental impact statement" (40 C.F.R. § 1502.14). The agency must "rigorously explore and objectively evaluate all reasonable alternatives" (40 C.F.R. § 1502.14(a), 40 C.F.R. § 1502.14(b)), and to identify the preferred alternative (40 C.F.R. § 1502.14(e)). The agency must consider the no action

alternative, other reasonable courses of action, and mitigation measures that are not an element of the proposed action (40 C.F.R. § 1508.25(b)(1)-(3)).

138

a. No Environmentally Superior Alternative is Identified.

The EIS/EIR fails to follow the law and significantly misleads the public and agency decision-makers in declaring that none of the proposed alternatives are environmentally superior. (EIS/EIR 2-39.) First, neither CEQA nor NEPA provide the lead agencies with discretion to sidestep this determination. As the Council on Environmental Quality (CEQ) has explained, “[t]hrough the identification of the environmentally preferable alternative, the decision maker is clearly faced with a choice between that alternative and the others, and must consider whether the decision accords with the Congressionally declared polices of the Act.”⁶⁵ CEQA provides that “[i]f the environmentally superior alternative is the “no project” alternative, the EIR shall also identify an environmentally superior alternative among the other alternatives.” (CEQA Guidelines § 15126.6(e)(2).)

139

First, the EIS/EIR fails to identify whether the “no project” alternative is environmentally superior to each other alternative. If that is the case, the EIS/EIR must then identify the next most environmentally protective or beneficial alternative. Here, the EIS/EIR presents evidence that Alternative 3 and Alternative 4 each would lessen the environmental impacts of the proposed project. The EIS/EIR however then shirks its responsibility to identify the environmentally superior alternative by casting the benefits of Alternatives 3 and 4 as mere “trade-offs.” This gross mischaracterization misleads the public and agency decision-makers, as the only “trade-off” between the proposed alternative and Alternatives 3 or 4 would be more or less adverse environmental effect.

The EIS/EIR argument that its conclusion that no project impacts are significant and unavoidable misses the point. Just as an EIS/EIR may not simply omit any alternatives analysis when there is purported to be no significant and unavoidable impact, neither can the agencies decline to identify the environmentally superior alternative. In fact, the proposed project would cause numerous significant and adverse environmental effects, and the EIS/EIR relies on wholly deferred and inadequate mitigation measures to lessen those effects, even allowing some level of significant impacts to occur before kicking in. But mitigation measures alone are not the only way to lessen or avoid significant project effects: the alternatives analysis performs the same function, and should be considered irrespective of the mitigation measures proposed.

140

b. Feasible Alternatives to Lessen Project Impacts are Excluded.

In light of the oversubscribed water rights system of allocation in California, changing climate conditions, and severely imperiled ecological conditions throughout the Delta, the EIS/EIR

141

⁶⁵ Forty Most Asked Questions Concerning CEQ’s NEPA Regulations, 48 Fed. Reg. 18,026 (Mar.16, 1981) Questions 6a.

should consider additional project alternatives to lessen the strain on water resources. Alternatives not considered in the EIS/EIR that promote improved water usage and conservation include:

Fallowing in the area of demand. The EIS/EIR proposes fallowing in the area of origin to supply water for the transfers yet fails to present the obvious alternative that would fallow land south of the Delta that holds junior, not senior, water rights. This would qualify as an, “immediately implementable and flexible” alternative that is part of the Purpose and Need section (p.1-2). Whether or not this is a preference for the buyers, this is a pragmatic alternative that should be fully explored in a recirculated EIS/EIR.

Crop shifting in the area of demand. The EIS/EIR proposes crop shifting in the area of origin to supply water for the transfers yet fails to present the obvious alternative that would shift crops south of the Delta for land that holds junior, not senior, water rights. Hardening demand by planting perennial crops (or houses) must be viewed as a business decision with its inherent risks, not a reason to dewater already stressed hydrologic systems in the Sacramento Valley. This would qualify as an, “immediately implementable and flexible” alternative that is part of the Purpose and Need section (p.1-2). Whether or not this is a preference for the buyers, this is a pragmatic alternative that should be fully explored in a recirculated EIS/EIR.

Mandatory conservation in urban areas. In the third year of a drought, an example of urban areas failing to require serious conservation is EBMUD’s flyer from October’s bills that reflects the weak mandates from the SWRCB.

- Limit watering of outdoor landscapes to two times per week maximum and prevent excess runoff.
- Use only hoses with shutoff nozzles to wash vehicles.
- Use a broom or air blower, not water, to clean hard surfaces such as driveways and sidewalks, except as needed for health and safety purposes.
- Turn off any fountain or decorative water feature unless the water is recirculated.

While it is laudable that EBMUD customers have cut water use by 20 percent over the last decade,⁶⁶ before additional water is ever transferred from the Sacramento River watershed to urban areas, mandatory usage cuts must be enacted during statewide droughts. This would qualify as an, “immediately implementable and flexible” alternative that is part of the Purpose and Need section (p.1-2). This alternative should be fully vetted in a recirculated EIS/EIR.

Land retirement in the area of demand. Compounding the insanity of growing perennial crops in a desert is the resulting excess contamination of 1 million acres of irrigated land in the San Joaquin Valley and the Tulare Lake Basin that are tainted with salts and trace metals like selenium, boron, arsenic, and mercury. This water drains back—after leaching from these soils

⁶⁶ <https://www.ebmud.com/water-and-wastewater/latest-water-supply-update>

the salts and trace metals—into sloughs and wetlands and the San Joaquin River, carrying along these pollutants. Retirement of these lands from irrigation usage would stop wasteful use of precious fresh water resources and help stem further bioaccumulation of these toxins that have settled in the sediments of these water bodies. The Lead and Approving Agencies have known about this massive pollution of soil and water in the area of demand for over three decades.⁶⁷ Accelerating land retirement could diminish south of Delta exports and provide water for non-polluting buyers. Whether or not this is a preference for all of the buyers, this is a pragmatic alternative that should be fully explored in a recirculated EIS/EIR.

141

Adherence to California's water rights. As mentioned above, the claims to water in the Central Valley far exceed hydrologic reality by more than five times. Unless senior water rights holders wish to abandon or sell their rights, junior claimants must live within the hydrologic systems of their watersheds. This would qualify as an, “immediately implementable and flexible” alternative that is part of the Purpose and Need section (p.1-2). Whether or not this is a preference for the buyers, this is a pragmatic alternative that should be fully explored in a recirculated EIS/EIR.

IX. The EIS/EIR Fails to Disclose Irreversible and Irretrievable Commitment of Resources, and Significant and Unavoidable Impacts.

Under NEPA, impacts should be addressed in proportion to their significance (40 C.F.R. § 1502.2(b)), and all irreversible or irretrievable commitment of resources must be identified (40 C.F.R. § 1502.16). And CEQA requires disclosure of any significant impact that will not be avoided by required mitigation measures or alternatives. CEQA Guidelines § 15093. Here, the EIS/EIR does neither, relegating significant impacts to groundwater depletion, land subsidence, and hardened demand for California’s already-oversubscribed water resources, to future study pursuant to inadequately described mitigation measures, if discussed at all.

142

a. Groundwater Depletion.

As discussed, above, the EIS/EIR groundwater supply mitigation measures rely heavily on monitoring and analysis proposed to occur *after* groundwater substitution pumping has begun, perhaps for a month or more. Only after groundwater interference, injury, overdraft, or other harms (none of which are assigned a definition or significance threshold) occur, would the EIS/EIR require sellers to propose mitigation measures, which are as of yet undefined. As a result, significant and irretrievable impacts to groundwater are fully permitted by the proposed project.

b. Subsidence.

Here, again, the EIS/EIR suffers the same flaw of only catching and proposing to mitigate

143

⁶⁷ <http://www.usbr.gov/mp/cvpia/3408h/>

subsidence after it occurs. But damages caused by subsidence can be severe, permanent, and complicated. The EIS/EIR does not purport to avoid these impacts, nor possibly mitigate them to less than significant levels. Instead, the EIS/EIR provides for “Reimbursement for modifications to infrastructure that may be affected by non-reversible subsidence.” This unequivocally provides for significant and irreversible impacts to occur.

143

c. Transfer Water Dependency.

The EIS/EIR fails to account for long-term impacts of supporting agriculture and urban demands and growth with transfer water. Agriculture hardens demand by expansion and crop type and urban users harden demand by expansion. Both sectors may fail to pursue aggressive conservation and grapple with long-term hydrologic constraints with the delivery of more northern California river water that has been made available by groundwater mining and following. Since California has high variability in precipitation year-to-year (<http://cdec.water.ca.gov/cgi-progs/iodir/WSIHIST>) (Exhibit Y), and how will purchased water be used and conserved? Should agricultural water users be able to buy Project water, how will DWR and the Bureau assure that transferred water for irrigation is used efficiently? Could purchased water be used for any kind of crop or landscaping, rather than clearly domestic purposes or strictly for drought-tolerant landscaping?

144

Without a hierarchy of priority uses among agricultural or urban users for purchasing CVP and non-CVP water, the EIS/EIR fails to ensure that California water resources will not go to waste, and will not be used to harden unsustainable demands.

X. The EIS/EIR Fails to Adequately Evaluate Growth-Inducing Impacts.

The EIS/EIR gives short shrift to the growth inducing impact analyses required under both CEQA and NEPA by absolutely failing to realize or by obfuscating the obvious: these types of Long-Term Water Transfers inherently lead to economic and population growth. Not only are the amount of water sales and types of water sales unknown to the Lead Agencies and the public, but once water is sold and transferred to the buyer agency, there are no use limitations or priority-criteria imposed on the buyer. Whether agricultural support or municipal supply, hydraulic fracturing, industrial use, or onward transfer, the potential growth inducing impacts, both economically and physically are limitless. And once agencies and communities are hooked on buying water to sustain economic conditions or to support development and population growth, while drought conditions continue or are exacerbated, unwinding the clock may prove impossible.

145

Growth inducing impacts are addressed in Section 15126.2(d) of the CEQA Guidelines, and the Council on Environmental Quality NEPA Sections 1502.16(b) and 1508.8(b). CEQA Section 15126.2(b) requires an analysis of a project’s influence on economic or population growth, or increased housing construction and the future developments’ associated environmental impacts. The CEQA Guidelines define growth inducing impacts as “...the ways in which the

proposed project could foster economic or population growth, or the construction of additional housing, either directly or indirectly, in the surrounding environment.” Under NEPA, indirect effects as declared in Section 1508.8(b) include reasonably foreseeable growth inducing effects from changes caused by a project.

145

A project may have characteristics that encourage and facilitate other activities that could significantly affect the environment, either individually or cumulatively. CEQA Guidelines section 15126.2(d) admonishes the planner not to assume that growth in any area is necessarily beneficial, detrimental, or of little significance to the environment. Included here are projects that would remove physical obstacles to growth, such as provision of new water supply achieved through Long Term Water Transfers. Removal of a barrier such as water shortages may lead to the cultivation of crops with higher-level water dependency and higher profit margins at market, or may supplement perceived and actual advantages of living in population-dense locales, leading to increased population growth.

146

The EIS/EIR states that direct growth-inducing impacts are typically associated with the construction of new infrastructure while projects promoting growth, like increased water supply in dry years, could have indirect growth inducing effects. Claiming that growth inducing impacts would only be considered significant if the ability to provide needed public services is hindered, or the potential for growth adversely affects the environment, the EIS/EIR then incorrectly concludes that the proposed water transfer from willing sellers to buyers, to meet existing demands, would not directly or indirectly affect growth beyond what is already planned. But the EIS/EIR does not describe “what is already planned,” nor how binding such plans would be.

Similar to the drought period in the late 1980’s and early 1990’s, urban agencies demand was approximately 40 percent of the transfer market. During that drought period, dry-year purchases were short term deals, intended to offset lower deliveries. However, this time around most of the transfer water is available to support longer-term growth, not solely to make up for shortfalls during droughts. Under current law, urban water agencies must establish long-term water supply to support new development, and long term transfers can provide this necessary evidence.⁶⁸

Adding to these concerns is the increase in fracking interests throughout the state, requiring large-scale water demand to extract oil and gas, run by companies with the financial ability to influence water rights through payment. While one county directly south of the boundary involving this proposed transfer agreement recently banned fracking, other counties in

⁶⁸ California Senate Bills 221 and 610, entered into law, 2001: requires agencies with over 5000 service connections and those with under 5000 service connections to demonstrate at least 20 years of available water supply respectively, for projects in excess of 500 residential units, or equivalent in combined residential and other demand (large service agencies), or for projects demanding least 10 percent growth in local water needs (small service agencies).

California are either involved in the practice of fracking, have yet to ban the practice, or have no interest in a fracking ban. Notably, the Monterey Shale Formation that stretches south through central California is in the buyer-area of the water districts served by this potential Long-Term Water Transfer Agreement. Without use limitations upon water transfers proposed within this agreement, water transferred under this plan may well be used for fracking

146

The EIS/EIR inappropriately fails to evaluate or disclose these reasonably foreseeable growth-inducing impacts.

XI. Conclusion

Taken together, the Bureau, SLDMWA, and DWR treat these serious issues carelessly in the EIS/EIR, the *Draft Technical Information for Water Transfers in 2013*, and in DWR's specious avoidance of CEQA review. In so doing, the Lead and Approving Agencies deprive decision makers and the public of their ability to evaluate the potential environmental effects of this Project and violate the full-disclosure purposes and methods of both the National Environmental Policy Act and the California Environmental Quality Act. For each of the foregoing reasons, we urge that the environmental review document for this project be substantially revised and recirculated for public and agency review and comment before any subject project is permitted to proceed.

147

Sincerely,



Barbara Vlamis, Executive Director
AquAlliance



Bill Jennings, Executive Director
California Sportfishing Protection Association



Jason Flanders
Aqua Terra AERIS Law Group

Summary

The Long-Term Water Transfers Environmental Impact Statement/Environmental Impact Report Public Draft (henceforth referred to as the “EIR/EIS”) articulates an ambitious plan to transfer water within the state of California. But this ambition is not matched by a similar degree of technical merit, as the modeling components of the EIR/EIS are potentially inadequate, inaccurate, and insufficient to the task. Because of this shortcoming, the EIR/EIS fails to demonstrate that environmental impacts of these transfers will be acceptably small. In particular, the groundwater substitution components of the proposed water transfers are based on modeling assumptions that likely limit their practical accuracy, and on computational simulation techniques that cannot be trusted for their intended use without additional work.

1

The EIR/EIS as written fails to make a technically-persuasive case for these water transfers, and therefore the proposed transfers should be rejected until the various water transfer stakeholders can advocate more effectively for these transfers by using sound scientific principles instead of mere assertions of negligible impact on the environment.

Critique Overview

This critique concentrates on the groundwater modeling portions of the EIR/EIS, as those portions of the EIR/EIS provide the least technical information relative to the importance of this particular part of the transfer plans. Groundwater resources are seldom seen directly, but their influence is present throughout the hydrological cycle. When the water table sinks, streams dry up and fish die. And when that phreatic surface drops below the level available to domestic water-supply wells, families lose their water supply. Groundwater mining is an all-too-common source of environmental woes, including irreversible loss of aquifer capacity and subsidence observable at the surface of the ground. So accurate groundwater modeling is an essential component of any trustworthy assessment of potential negative environmental effects.

2

This critique focuses on four particular aspects of the groundwater modeling efforts outlined in the EIR/EIS, namely:

- the lack of a defensible technical basis for the use of the SacFEM2013 groundwater model in assessing man-made hazards due to groundwater substitution activities,
- the inherent assumptions and potential inaccuracies present in the SacFEM2013 model, including an exposition of how better groundwater modeling techniques could have been deployed to engender more trust in the computed results,
- the lack of any formal characterization of uncertainty in the model that might be used to assess the impact of those SacFEM2013 model inaccuracies, and
- some general comments on the EIR/EIS’s all-too-often inadequate technical treatment of aquifer mechanics.

3

Sins of omission and commission are thus found in the EIR/EIS, and this critique will attempt to guide the reader through a discussion of each, towards the goal of more accurate and technically-defensible modeling that would be required to support the proposed water transfers.

Professional Background

My professional experience has long been concentrated in the development and deployment of large-scale computational models for engineered and natural systems. I have worked in this professional field for well over thirty years, and have published refereed journal publications on subsurface mechanics and computational simulation of geological processes, as well as texts and related educational works on computational modeling in solid and fluid mechanics. I have served as a regular faculty member on the Civil Engineering faculties of two major U.S. research universities (the University of California, Davis, and the University of Oklahoma), as well as in leading-edge technical and administrative capacities at federal national laboratories. With my academic colleagues and graduate students, I have published journal articles and technical reports on aquifer mechanics, computational geomechanics, fluid-solid interaction, high-performance computing, and on the inherent limits to accuracy of computational modeling for complex systems in the presence of inherent uncertainties. I have earned M.S. and Ph.D. in Civil Engineering and a B.S. in Mathematics, all from the University of California, Davis. I have lived in Northern California for more than one-half of my adult life, and have long provided *pro bono* technical assistance on science and engineering topics of import to the quality of life for residents of California. My current work involves simulation of complex man-made and natural systems using some of the largest computers in the world, and so I am well-equipped to describe the state-of-the-art in predictive modeling for large-scale water transfers in California.

Overview of Technical Concerns

This review focuses primarily on the groundwater substitution aspects of the EIR/EIS, because those aspects are where my own expertise is deepest. The groundwater model utilized in the EIR/EIS has enough shortcomings to call into question the trustworthiness of the entire EIR/EIS, and until these shortcomings are remedied, such groundwater transfers should not be permitted. Some representative problems with the SACFEM2013 model are presented below.

Fundamental Technical Problems with the SacFEM2013 Model

In simplest terms, the EIR/EIS fails to make a compelling case for the use of the SacFEM2013 groundwater model in assessing man-made hazards due to groundwater substitution activities.

For example Appendix D of the EIR is provided to document the SacFEM2013 model, but this section of the EIR/EIS raises more questions than answers about the suitability of the model. Some of the assertions made in Appendix D are incorrect, while others are irrelevant to the purpose of the EIR/EIS. And the most fundamental problem with the information presented on the SacFEM2013 model is that Appendix D fails to provide enough technical context to justify the use of SacFEM2013. A technically-informed citizen interested in providing accurate public commentary on the EIR/EIS must search the literature and other open-source documents to find relevant information about the suitability of the SacFEM2013 model. Unfortunately, these searches prove fruitless, because there simply is not enough information provided in the EIR/EIS to perform a technically-defensible characterization of the suitability of SacFEM2013. Because of this, some of the my comments include qualifiers such as “appears to be” or “apparently”. These qualifiers do not imply any insufficiency in my own understanding: they are explicit reminders that the EIR/EIS fails to provide an adequate technical basis for use of SacFEM2013.

One example of incorrect modeling assertions in the EIR/EIS is the characterization¹ of SacFEM2013 and its parent code MicroFEM as “three-dimensional” and “high-resolution”. In fact, the SacFEM2013 model provides only a linked set of two-dimensional analyses², and would more charitably be described as “two-and-a-half dimensional” instead of possessing a fully-3D modeling capability. This limitation is not an unimportant detail, as a general-purpose 3D groundwater model could be used to predict many important physical responses, e.g., the location of the phreatic surface within an unconfined aquifer. For the SacFEM2013 model, this prediction is part of the data instead of part of the computed solution, and hence SacFEM2013 apparently has no predictive capability for this all-important aquifer response. Here is the relevant EIR/EIS content on this topic³:

The uppermost boundary of the SACFEM2013 model is defined at the water table. To develop a total saturated aquifer thickness distribution and, therefore, a total model thickness distribution, it was necessary to construct a groundwater elevation contour map and then subtract the depth to the base of freshwater from that groundwater elevation contour map. Average calendar year groundwater elevation measurements were obtained from the DWR Water Data Library. These measurements were primarily collected biannually, during the spring and fall periods; and these values were averaged at each well location to compute an average water level for each location. These values were then contoured, considering streambed elevations for the gaining reaches of the major streams included in the model, to develop a target groundwater elevation contour map for the year 2000.

5

Note that, in order to begin a SacFEM2013 analysis, the phreatic surface must be specified instead of predicted, and that this specification is based on past records of water table location instead of on verifiable accurate predictions of future groundwater resources. Since California is currently in an unprecedented drought, and because the assessment of similarly-unprecedented future large-scale groundwater transfers is the whole point of the EIR/EIS, it is technically inappropriate to use an averaged historical basis to locate the water table surface simply because the SacFEM2013 is unable to predict that important parameter from first principles!

A good example of an irrelevant assertion in the EIR/EIS is the list of reasons given⁴ why MicroFEM was chosen as the modeling platform. The first reason is true of *any* finite-element code used to model groundwater response, and the second and third arise from the existence of a graphical user interface for the model input and output data. Any modern computational tool (e.g., the word-processing application I’m using to write this critique) possesses such a user interface, so all three reasons apply equally well to any well-designed finite element application, yet they are used to motivate the choice of only one such application. Why this specific choice of MicroFEM was made is never developed in the EIR/EIS, but it should be, as with the choice of computational model comes a set of model constraints that can limit the model’s utility.

6

Technical sidebar: *finite element models are particularly easy to develop and deploy graphical user interfaces for, because the interpolation scheme used to generate the finite element results provides uniquely-defined and easy-to-compute results for every point in the spatial domain. In addition to this readily-accessible supply of spatial data available for visual interpretation of results, these models also can produce results at regular time*

¹ EIR/EIS, Appendix D, Page 1

² S.A. Leake and P.A. Mock, “Dimensionality of Ground Water Flow Models”, *Ground Water*, Volume 35, Number 6, Page 930, 1997

³ EIR/EIS, Appendix D, Page 4

⁴ EIR/EIS, Appendix D, Page 1

intervals (e.g., monthly) that make it easy to generate animations of the spatial data. So the presence of a graphical user interface is a poor reason to choose a particular finite element application, as custom visualization tools are readily developed at low cost to support the use of the model, or public-domain visualization tools can be utilized instead.

6

Unfortunately for the results presented in the EIR/EIS, MicroFEM is a poor choice for such large-scale modeling. It is an old code that apparently utilizes only the simplest (and least accurate) techniques for finite-element modeling of aquifer mechanics, and MicroFEM (and hence SacFEM2013) embed serious limitations into the model that compromise the accuracy of the computed results. These limitations include, but are not limited to, the following:

- The model places a remarkably-low upper limit on problem resolution, i.e., 250,000 surface nodes are available to the modeler, but no more. This limit would appear to the technically-oriented reader to indicate that the advanced age of the MicroFEM program has constrained its software architecture so that high-resolution and high-fidelity models are beyond its capabilities. In particular, its MS/DOS origins might indicate an inability to address sufficient computer memory to support a higher-resolution model, or that its solver routines do not scale to support the multiple-processor capabilities available on virtually all current computers. If this is the case, then this problem should be explicitly noted in the EIR/EIS as a model limitation. If it is not the case, then some justification for this upper limit should be provided to aid in the impartial evaluation of the SacFEM2013 model.
- As mentioned above, the SacFEM2013 model is only partially predictive, in that some aquifer responses are entered as input data instead of being computed as predictive quantities. The most serious of these is the lack of ability to predict the location of the phreatic surface in the aquifer. This location is a natural candidate as the single the most important predicted quantity available for understanding near-surface environmental effects of groundwater motion, yet it is apparently not computed by SacFEM2013, which instead relies on its location via the a priori data-entry process quoted above.
- As mentioned earlier, the model is not a three-dimensional model, but instead estimates groundwater response via approximations involving a suite of two-dimensional layers with uniform horizontal permeabilities coupled via estimated leakage parameters that represent the actual three-dimensional flow fields of groundwater resources. The limitations of this self-induced model constraint are outlined in more detail below, but the summary is simple enough: the real-world complexities of California's groundwater aquifers are over-simplified by the SacFEM2013 model into no more than 25 available two-dimensional layers of uniform composition, and hence the model results are at best computational simplifications not necessarily representative of actual groundwater responses to pumping.

7

8

9

In addition to the model not being a true 3D model of the actual geometric nature of the state's groundwater resources, some other problems with the model include the following:

- The model requires considerable data manipulation to be used, and these manipulations are necessarily subject to interpretation. This fact implies that the model results depend on the choices made by the analyst, and are hence not necessarily reproducible. In other words, adjusting of the results (by accident or by design) is an inherent characteristic of the model, and that characteristic alone erodes trust in the model. There are technically-defensible ways to provide accurate assessments of how such adjustments might affect output results used in

10

decision-making (e.g., sensitivity analyses for these parameters), but these means for evaluating trust in the model are not mentioned in the EIR/EIS, and one can only conclude that they have never been performed.

- The model description in the EIR/EIS presents no validation results that can be used to provide basic quality-assurance for the analyses used in the EIR/EIS. The reader can seek information on the parent code MicroFEM, but precious little data is available on that code's capabilities, so the question of "can the results of this model be trusted?" is not answered by the EIR/EIS. An expert reviewing the EIR/EIS might seek to examine the MicroFEM code directly, but the underlying source code is not available, and the MicroFEM tool can only be purchased for a substantial fee (\$1500), so it is infeasible to gain informed public comment on the suitability of MicroFEM or SacFEM2013 without paying a substantial price.
- The model is not predictive in some aquifer responses (as mentioned above), so its results are a reflection of past data (e.g., streamflows, phreatic surface location, etc.) instead of providing a predictive capability for future events. Since accurate prediction of future environmental effects is the whole point of the EIR/EIS, the SacFEM2013 model is arguably not even suitable for use in the EIR/EIS, much less in real-world hydrological practice.

The problem of data manipulation mentioned in the first bullet above represents a serious limitation of the SacFEM2013 model. Model quality can be measured by standard quality-assurance processes utilized for software development, such as the CMM model⁵ widely used in software practice. The five stages of increasing quality in the CMM model are termed ad hoc (or chaotic), repeatable, defined, managed, and optimized, and the repeatable stage is generally accepted as the minimal level of quality appropriate for any critical analysis methodology. Since analyst intervention in data preparation creates an obvious risk of analyst dependencies in the output data used to set policy, the current SacFEM2013 workflow is likely only at the "ad hoc/chaotic" state of quality assurance for a model. This is simply not appropriate for critical analyses that are used in decision-making on such important resources as water in California.

A typical example of analyst intervention in data preparation can be found in Appendix D of the EIR/EIS⁶:

After a transmissivity estimate was computed for each location, the transmissivity value was then divided by the screen length of the production well to yield an estimate of the aquifer horizontal hydraulic conductivity (Kh). The final step in the process was to smooth the Kh field to provide regional-scale information. Individual well tests produce aquifer productivity estimates that are local in nature, and might reflect small-scale aquifer heterogeneity that is not necessarily representative of the basin as a whole. To average these smaller scale variations present in the data set, a FORTRAN program was developed that evaluated each independent Kh estimate in terms of the available surrounding estimates. When this program is executed, each Kh value is considered in conjunction with all others present within a user-specified critical radius, and the geometric mean of the available Kh values is calculated. This geometric mean value is then assigned as the representative regional hydraulic conductivity value for that location. The critical radius used in this analysis was 10,000 meters, or about six miles. The point values obtained by this process were then gridded using the kriging algorithm to develop a Kh distribution across the model domain. The aquifer transmissivity at each model node within each model layer was then computed using the geometric mean Kh values at that node times the thickness of the model layer. Insufficient data were available to attempt to

⁵ M.C. Paulk, C.V. Weber, B. Curtis, M.B. Chrissis, "Capability Maturity Model for Software (Version 1.1)". Technical Report, Software Engineering Institute, Carnegie Mellon University, 1993

⁶ EIR/EIS, Appendix D, Page 13

subdivide the data set into depth-varying Kh distributions, and it was, therefore, assumed that the computed mean Kh values were representative of the major aquifer units in all model layers. The distribution of K used throughout most of the SACFEM2013 model layers is shown in Figure D-4. During model calibration, minor adjustments were made to the Kh of model layer one east of Dunnigan Hills and in model layers six and seven in the northern Sacramento Valley based on qualitative assessment of Lower Tuscan aquifer test data in this area.

Note the presence of terms such as “adjustments”, “assumed”, “insufficient data”, and “representative”. What is being described in this paragraph is a potentially non-repeatable process that converts the three-dimensional permeability tensor into a homogenized number Kh that is then used to estimate conductivity in a plane parallel to the ground surface. Permeability is a local tensorial property of the aquifer (i.e., it varies from point to point in the 3D subsurface domain), but the resulting Kh is smeared across the domain to convert this tensor with six independent spatially-dependent components into a single number that is applied over a huge geographical area instead. And this conversion is subject to the judgment of each analyst, so the results depend on the skill (or lack thereof) of the particular analyst doing the modeling.

***Technical sidebar:** it is remarkably straightforward to perform accurate and technically-defensible computational analyses to assess the ultimate effect of these data adjustments. One of the most easily-deployed of these techniques is the use of a sensitivity analysis that measures how computed output results depend on adjustments to input parameters. Sensitivity analyses are readily grafted onto nearly any computational model, and while these computations require more effort than not using them, most of the additional effort can readily be offloaded to the computer, so that undue levels of human efforts are not required for their application. Formal sensitivity analyses can also be used to aid in the assessment of model uncertainty (see discussion below), so their omission in the EIR/EIS is a mystery to the technically-informed impartial reviewer of the EIR/EIS.*

And that’s only the tip of the larger iceberg of problems with these ad hoc techniques. It is actually quite easy to avoid all these adjustments and oversimplifications entirely, and treat the aquifer as it is, namely as a true three-dimensional physical body of large extent, with a time-varying location of the water table, and with accurate treatment of the complex hydraulic conductivity inherent to the subsurface conditions of California. It’s also remarkably simple to include poromechanical effects (see discussion below) in such a 3D model so that accurate local and regional estimates of environmental impacts such as subsidence and loss of aquifer capacity can be predicted and validated. All of this technology has been available for decades, but it is not utilized in the SacFEM2013 model. *The citizens of California clearly deserve a better model for decision-making involving one of their most precious resources!*

Regarding The Need to Characterize Uncertainty in Engineered and Natural Systems

Some discussion is warranted at this point on the difference between a natural and an engineered system, towards the goal of appreciating why characterizing uncertainty in any proposed water-transfer strategy is an essential goal of a well-considered EIR/EIS. An engineered system is designed entirely by humans, so each component of that system is reasonably well-understood *a priori*, and the uncertainties that are inherent in any system (natural or man-made) are limited to defined uncertainties such as materials chosen, geometric specifications, and conditions of construction and use. So an engineered system such as an automobile (or a groundwater-pumping facility) is uncertain in many aspects, but that uncertainty can in theory be constrained

13

14

15

by quality-control efforts or similar means of repeatability. Constraining these uncertainties comes at a price, of course: that is a large part of what we mean when we refer to *quality* in an engineered system such as in cars or consumer electronics.

A natural system has a much higher threshold for uncertainty, as we often do not even know of all the components of the system, much less their precise characterization (e.g., in a water-bearing aquifer, the materials that entrain the water are by definition unavailable for characterization, and the mere act of digging some of them up for laboratory inspection often changes their physical behaviors so that the tests we perform in the laboratory may not be entirely relevant to the response of the actual subsurface system). So when studying a natural system, a scientist or engineer must exercise due diligence in the examination and characterization of the system's response to stresses of operational use, and must consistently provide means to determine the presence and effect of these inherent uncertainties. To do otherwise is to risk visitation by Murphy's Law, i.e., "anything that can happen, will happen."

Thus one of the most obvious metrics for evaluating the quality of any environmental plan is to examine the plan's use of terms such as "uncertainty", as well its technical relatives that include "validation" (testing of models via physical processes such as laboratory experiments), "verification" (testing of models via comparison with other generally-accepted models), and "calibration" (tuning a model using a given set of physical data that will be used as initial conditions for subsequent verification, validation, and uncertainty characterization). These basic operations are fundamental characteristics of any computational model, and are used in everyday life for everything from weather prediction (where uncertainty dominates and limits the best efforts at forecasting) to the simple requirement that important components of infrastructure such as highway bridges be modeled using multiple independent analyses to provide verification of design quality before construction can begin.

Unfortunately, the EIR/EIS does not contain a formal characterization of model uncertainty, either for the SacFEM2013 application itself, or for the underlying data gathered to support the SacFEM2013 analyses. As described in previous sections, both the model and the input data contain simplifications that potentially compromise the model's ability to provide accurate estimates of real-world responses of water resources, and these idealizations create *more* need for uncertainty characterization, not less. And the all-important technical terms "validation" and "verification" do not appear the EIR/EIS. The term "calibration" occurs twice⁷ with regard to groundwater models, but only in the context of ad-hoc "adjustments" of the model data.

Lack of Trust in the SacFEM2013 Model

In addition to generally-poor modeling assumptions inherent in the SacFEM2013 model, the all-important task of characterizing uncertainty in the model's implementation and data is neglected in the EIR/EIS. On page 19 of Appendix B, the reader is promised that model uncertainty will be described in Appendix D, but that promise is never delivered: the only mention of this essential modeling component occurs merely as an adjunct to discussion of deep percolation uncertainty.

⁷ EIR/EIS, Appendix D, Pages 10 and 13

This lack of any formal measure of uncertainty is not an unimportant detail, as it is impossible to provide accurate estimates of margin of error without some formal treatment of uncertainty. Many such formal approaches exist, but apparently none were deployed for the EIR/EIS modeling efforts. In simple terms, this lack of uncertainty characterization removes the basis for trust in the model results, and hence the entire groundwater substitution analysis presented in the EIR/EIS is not technically defensible. Until this omission is remedied, the EIR/EIS simply proposes that water interests in California trust a model that is arguably not worthy of their trust.

16

And it's even worse than this, as while the model is asserted to be "high-resolution", in fact the SacFEM2013 model is quite the opposite. The actual spatial resolution of the model is given in Appendix D as ranging from 125 meters for regions of interest, up to 1000 meters for areas remote from the transfer effects. Nodal spacing along flood bypasses and streams is given as 500 meters. No mention is made in the EIR/EIS of exactly what this means in terms of trust in the model, but in accepted computational modeling practice, this is not a particularly high resolution.

In fact, there are formal methods for characterizing the ability of a discretized model such as SacFEM2013 to resolve physical responses of interest. These methods are based on elementary aspects of information theory (e.g., the Nyquist-Shannon sampling theorem), and their practical result is that a discrete analog (i.e., a computer model) of a continuous system (i.e., the actual subsurface geological deposits that entrain the groundwater) cannot resolve any feature that is less than a multiple of the size of the discretization spacing. For regular periodic features (e.g., the waveforms that make radio transmission possible), that multiple can be as small as two, but for transient phenomena (e.g., the response of an aquifer), established practice in computational simulation has demonstrated that a factor of five or ten is the practical limit on resolution.

Thus the practical limit of the SacFEM2013 model to "see" (i.e., to resolve) any physical response is measured in kilometers! The model can compute results smaller than this scale, but those results cannot be implicitly trusted: they are potentially the computational equivalent of an optical illusion. For this reason alone, the SacFEM2013 model cannot be trusted without substantial follow-on work that the EIR/EIS gives no indication of ever having been performed. And thus any physical response asserted by the model's results has a margin of error of 100% if that response involves spatial scales smaller than a kilometer or more, i.e., there is little or no predictive power in the model for those length scales.

17

The additional verification effort required to gain some measure of trust in the model (i.e., refining the nodal spacing by a factor of two and four to create more refined models, and then comparing these higher-resolution results to gain assurance that no computational artifacts exist in the original model, i.e., no optical illusions are being used to set water transfer policy) is quite straightforward and is also standard practice in verifying the utility of a computational model. It is something of a mystery why this standard modeling quality-assurance technique is not presented in the EIR/EIS, but this omission provides yet-another sound technical reason to reject the results of the EIR/EIS until better modeling efforts are provided.

***Technical sidebar:** one important side benefit of performing verification studies by refining the finite element mesh in the spatial and temporal domains is that this extra effort provides important information as to whether the resolution of the model is sufficient. In practice, improving the resolution of a computer model is only a means to*

the desired end of gaining higher fidelity, i.e., a closer approximation to reality. So what we really desire from a computer model is not resolution, but fidelity, and while it is notoriously difficult to assess measures of fidelity, verification techniques based on refining the finite element mesh do provide some measure of trust in model results. One particularly simple verification measure involves plotting the computed results for a quantity of interest (e.g., groundwater flux at some point in the aquifer) as a function of model resolution (e.g., a metric indicating the number of the elements in the model, or a representative spatial scale used) for successive refinements of the finite-element mesh. Such plots help the analyst estimate whether the results at any given resolution yield an asymptotically-accurate estimate of the best results the model can provide given its inherent modeling assumptions. When combined with validation data (e.g., model predictions compared to real-world measured data), these verification-and-validation techniques provide a more sound basis for trust in the model than the minimal motivations found in the EIR/EIS.

17

It is likely that the SacFEM2013 model may be incapable of performing these more refined higher-resolution analyses because of its underlying assumptions (e.g., idealizing the three-dimensional subsurface domain as a set of coupled two-dimensional layers), and if that is the case, then the underlying groundwater model is simply not up to the requirements of accurate regional water transfer modeling. The underlying MicroFEM model is an old simulation tool, originally written for the MS/DOS platform, and it appears to be near the practical limit of its resolution at the stated size⁸ of 153,812 nodes (compared to the maximum nodal resolution in MicroFEM of 250,000 nodes cited above). But the current generation of desktop computers can easily handle many millions of nodes for such simulations, and enterprise computers well within the budgets of government agencies are routinely utilized to model systems with hundreds of millions of nodes, so if the SacFEM2013 model is already at its limit of resolution, then it's clear that a newer, better computational model should be used to replace it.

Inadequacy of Basic Aquifer Mechanics Principles in the EIR/EIS

In addition to all the fundamental problems inherent in the SacFEM2013 model, the EIR/EIS presents a biased view of basic principles of aquifer mechanics, and this bias serves to understate the risks of serious environmental problems that have long been a bane of water policy in California. In particular, the EIR/EIS simply understates the risk of these environmental effects, beginning with its executive summary and continuing throughout the rest of the document. Here's a representative sample of the problem at its first occurrence⁹:

18

Groundwater substitution would temporarily decrease levels in groundwater basins near the participating wells. Water produced from wells initially comes from groundwater storage. Groundwater storage would refill (or "recharge") over time, which affects surface water sources. Groundwater pumping captures some groundwater that would otherwise discharge to streams as baseflow and can also induce recharge from streams. Once pumping ceases, this stream depletion continues, replacing the pumped groundwater slowly over time until the depleted storage fully recharges.

⁸ EIR/EIS, Appendix D, Page 3

⁹ EIR/EIS, Executive Summary, Page 10

The use of the adverb “fully” implies that the original storage is entirely recovered, but this is not necessarily the case. The science of poromechanics demonstrates that irreversible loss of aquifer capacity can occur with groundwater extraction, and while this physical phenomenon is explained elsewhere in the EIS/EIR, it is apparently ignored by the SacFEM2013 model, and hence it is not predicted with any degree of accuracy for use in estimating this important environmental effect. California has seen many examples of the accumulation of this environmental risk, as the readily-observable phenomenon known as subsidence is the surface expression of this loss of aquifer capacity. The small strains induced in the aquifer skeleton by groundwater extraction accumulate over the depth of the aquifer, and are expressed by the slow downward movement of the ground surface. The EIR/EIS makes little connection between groundwater extraction process modeled by SacFEM2013 and the all-too-real potential for surface subsidence, and the attendant irreversible loss of aquifer capacity. It is remarkably simple to model these coupled fluid- and solid-mechanical effects using modern computers, and it is thus a fatal shortcoming of the EIR/EIS that such a rational science-based approach to estimating these environmental risks has not been undertaken.

18

The problem is especially important during drought years, when groundwater substitution is most likely to occur. In a drought, the aquifer already entrains less groundwater than normal, so that additional stresses due to pumping are visited upon the aquifer skeleton. This is exactly the conditions required to cause loss of capacity and the risk of subsidence. Yet the EIR/EIS makes scant mention of these all-too-real problems, and no serious modeling effort is presented in the EIR/EIS to assess the risk of such environmental degradation.

Taken together with the other problems catalogued above, it is clear that the EIR/EIS does not accurately estimate potential environmental risks due to groundwater extraction. And since this component of the water transfer process is only one aspect of how water might be moved within the state, the interested reader of the EIR/EIS can only wonder what other important environmental effects have not been accurately assessed in the EIR/EIS.

19

Conclusions

The current draft version of the EIR/EIS fails to accurately estimate environmental effects likely to occur during water transfers. The model used to predict groundwater resources is flawed by being based on old technology that is apparently not up to the task of accurate large-scale modeling as combined with requisite validation measures and uncertainty characterization efforts needed to justify the use of the model. The reasons given for the use of this model do not stand up even to the most rudimentary examination, and the model neglects important environmental effects that have long been observed in California. The proposed transfers should be rejected until a more sound scientific basis can be established for prediction of all substantial environmental effects, and established practices in the use of computational models are developed and deployed in all aspects of computational prediction of those effects.

20

Comments on:

LONG TERM TRANSFERS EIR/EIS REVIEW OF EFFECTS ON SPECIAL STATUS FISH

1. INTRODUCTION

Long term transfers represent Reclamation and San Luis Delta Mendota Water Authority’s ability to move water from north of the Delta to south of the Delta using its Central Valley Project storage, conveyance, and export facilities, and associated authorities. The EIS/EIR describes the details and effects of Reclamation’s actions to carry out such transfers. Water for transfers would come from stored and saved water north of the Delta that would be delivered in summer south of the Delta. The amount of water proposed for transfer by Reclamation could be up to 600,000 af (Federal Register and EIS/EIR at p. 1-5), but is likely to be over 200 thousand acre-ft. Reclamation’s EIS/EIR covers myriad proposed transfers. Some additional proposed State transfers are addressed in the EIS/EIR cumulative impacts assessment.

1

CSPA has undertaken a review of transfers and the EIS/EIR effects analysis on special status fish species. The species addressed include Chinook salmon, Steelhead, Green and White sturgeon, and Longfin and Delta smelt. These fish all depend on Central Valley river and Delta flows and habitats for portions of their life cycles. A summary of this review is presented in this report.

2. SUMMARY OF CSPA COMMENTS ON SECTION 3.7

A. Effects of Transfers

1. Change in timing and amount of river flows

Table C2 shows that summer Delta inflows from the Sacramento River in dry and critical water years may increase by several thousand cfs to accommodate transfer Delta exports. With non-CVP transfers the total change is not inconsequential. With minimum river flows of 3000-5000 cfs, transfers can double river flow and Delta inflow in summer of drier years when reservoir levels are low and water deliveries are cut back. **Holding Delta outflow near minimum and nearly doubling inflow and exports warms the Delta, increases loss of Delta fishes to export pumps, and degrades freshwater and low salinity zone habitat. For more discussion of this effect see Attachments A and B.**

2

River flows in winter can be lower by 10-20% in dry years as previous year’s transfer releases are made up by reservoir water retention. Rivers flows may be reduced by

3

over 1000 cfs although usually in higher precipitation months. **The refill of reservoirs the year after summer transfers reduces winter river flows and Delta inflow. The effect is greatest in drier years when river flows and reservoir releases are at a minimum. These indirect winter effects though not as dramatic as direct summer transfer effects have consequences to drier year winter river rearing and migration habitat of salmon and smelt.**

3

Overall effects from flow changes:

- **Significant negative effect on winter run salmon: (1) young rearing in lower Sacramento River in summer, (2) smolt migration in winter, (3) adult upstream migration in winter.**
- **Significant negative effect on delta smelt: (1) young rearing in the Delta in summer of drier years, (2) adults migrating upstream into Delta during winter.**

2. Changes in Delta Exports

Tables C8 and C9 show expected increases in drier year summer exports in the range of 20-60% from CVP transfers. With non-CVP transfer exports of similar magnitude, total drier year exports are near double or even more in critical years like 2014. **Higher exports increase entrainment and salvage losses of fish and degrade Delta rearing habitat (higher water temperatures, lower turbidity, and lower primary and secondary production).**

4

Overall effects from export increases in summer:

- **Significant negative effect on delta smelt: (1) from increased entrainment of young rearing in the Delta in summer of drier years, (2) from degradation of rearing habitat of young.**

3. Changes in water source

Water released from reservoirs for transfers in summer is not the same water exported from the Delta. Exports from the South Delta in summer of drier years typically take the cooler, slightly brackish, productive upper low salinity zone that has been in residence in the Delta for some time. The exported water includes nearly all the higher productivity water of the San Joaquin River that enters the Delta. Exported water is replaced by reservoir water including that released for transfers. The added reservoir water in higher Delta inflows degrades Delta habitat with fresher, warmer, clearer water.

5

Overall effects from changes:

- **Significant negative effect on delta smelt from degradation of rearing habitat of young in north, south, and west Delta, and eastern Suisun Bay.**

4. Changes in reservoir storage

As it may take several years or more to replace reservoir water released for transfers, reservoir storage is depleted by transfers in multiyear droughts. Reservoir depletion

6

over several years may reach 500,000 ac-ft or more total. Long term droughts already deplete reservoirs to the point of affecting cold water pools and winter-spring releases that benefit fish especially in droughts. Storage releases in the summer of 2014 were in fact higher than planned or believed needed to sustain transfers, other water demands, and outflow and water quality requirements. Thus the true effect of transfers on reservoir storage is unknown.

Reductions in cold water pools can lead to (1) adult salmon being susceptible to diseases from warm water, (2) delays in salmon spawning, (3) reduced survival of eggs and embryos, (4) lower young survival during rearing, and (5) and delays and lower survival of smolts during emigration.

Overall effects from reservoir storage reductions:

- **Significant negative effect on winter run salmon in multiyear droughts: (1) young rearing in lower Sacramento River in summer, (2) migrating smolts in winter, (3) eggs and embryos in summer, and (4) adults from lower winter attraction flows in multiyear droughts.**

B. Cumulative Effects

We believe the addition of water transfers places significant added burden on the special status fish species over that already imposed by climate change, drought, increasing water supply use, record-high Delta diversions, increasing demands on surface and groundwater, as well as increased demand forecasted under the BDCP. The EIS fails to address these factors, although it does mention the potential of added effects from other Central Valley transfers through the Delta (i.e., by State Water Project and non-project water) not covered by the EIS. The EIS acknowledges these effects, but simply states that the added and cumulative effects are insignificant without any analyses as to whether the severely depressed populations and habitats of special status species are potentially affected by the added stress. Based on our assessment of cumulative effects, significant added stresses would occur on the fish and their habitats:

1. *Winter Run Salmon*

The cumulative effects of the above stresses with addition of water transfers will put winter-run in continuing jeopardy and inhibit their recovery. Transfers reduce reservoir storage in multiyear droughts as transfer storage releases cannot be made up until wet years again occur. Low storage limits the amount of Shasta Reservoir cold water pool to sustain winter run through summer spawning, incubation, and rearing. Continuing low fall releases limits the extent of rearing habitat and early emigration cues. Higher August and September flows from reservoir transfer releases may improve early rearing habitat in the upper Sacramento River near Redding, but may also deplete the cold-water pool and send emigration cues that may push young into warmer portions of the lower Sacramento River. Low storage levels in multiyear droughts limit the available water for storage releases in winter to sustain young emigration and upstream adult migration through the Delta and Bay to and from the Pacific Ocean.

2. *Spring and Fall Run Salmon*

Lower river flows in winter and spring in drier years would effect downstream emigration success of fry to the Delta. Poor dry year Delta rearing habitat would be further degraded by lower Delta inflows. High late summer transfers would encourage early migrations and maturation of adult fall run only to subsequently be subjected to lower fall flows and higher water temperatures.

9

3. *Delta Smelt and Longfin Smelt*

Adult migration and spawning success would be negatively affected by lower Delta winter and spring inflows in multiyear droughts. Lower Delta inflow in late winter and springs of multiyear droughts will reduce survival of young smelt. Higher summer Delta inflows will reduce survival of rearing pre-adult smelt in the Delta from degradation of the low salinity zone and direct and indirect losses to higher Delta exports.

10

C. Are the Effects of Transfers Unreasonable?

Reclamation argues that the effects of transfers are not “unreasonable”. Their main argument is that the BOs state that planned summer transfers up to 600,000 ac-ft would not constitute jeopardy, and that NMFS and USFWS have “OK’d” individual transfers in summer 2014 and past years. The facts are that winter-run salmon and delta smelt populations have further declined significantly since the BOs were prepared. Based on the present situation after two recent periods of drought (6 of last 8 years being dry or critical) we believe the predicted added stress of the whole array of planned transfers is an unreasonable threat to listed salmon and smelt.

11

D. Reasonableness of Reclamation’s Assessment in EIS

As shown in Tables 2-9 and 2-10, the Proposed Action in Reclamation’s opinion would not have any significant, unavoidable adverse impacts. From our review the proposed transfers have significant potential effects that are avoidable. Our review shows that potential effects are greatest in multiyear droughts when listed fish are already under maximum stress. Many of the most significant effects can be avoided by limiting transfers in the second or later years of drought. A more detailed review might yield specific criteria or rules that would allow some transfers to occur under certain circumstances. If transfers cannot be avoided, then other types of restrictions on water supply storage or deliveries could be considered to reduce effects of transfers and risks to the listed species.

12

E. Flaws in Reclamation’s Assessment

Major flaws in Reclamation’s assessment are as follows:

- 1) Reclamation assumes delta smelt are not found in the Delta in the summer transfer season, when in fact during dry and critical years when transfers would occur most if not all delta smelt are found in the Delta (see Attachments A and B).

13

- 2) Reclamation downplays the potential total amount of all transfers, when in fact the capacity exists for transfer amounts up to 600,000 ac-ft (see EIS/EIR CHART BELOW). *“The “up to” amount of transfer water that could be made available in any year is approximately 473,000 acre-feet. However, it is unlikely that this amount of water could be transferred in any year due to Delta regulatory and other constraints.”* (Source: http://www.usbr.gov/mp/PA/water/docs/2014_water_plan_v10.pdf)
- 3) Reclamation has not assessed the effect on Delta habitat in terms of water temperature, turbidity, and location of the Low Salinity Zone.
- 4) Reclamation has failed to address population level effects on listed fish.
- 5) Reclamation has failed to follow the State Board’s recommendation: *““The key is to follow the water, not the agreements. Focus on the source of the actual water moving to the transferee. This is the water being transferred and will guide the types of changes in water rights that may be needed.”* (p 10-3 of SWRCB Guide to Water Transfers.). Reclamation has failed to identify that the water they divert for transfer in the Delta is not the water released upstream for transfer.
- 6) Reclamation has failed to assess the cumulative effects on listed fish in multi-year droughts and the consequences of adding transfers on top of emergency drought actions designed to save storage by reducing water demands, exports, and relaxing water quality standards. Reclamation failed to mention its own requests to the State Board for Temporary Urgency Changes in 2013 and 2014 including provisions to exempt transfers from the TUCs that allowed lower Delta outflow and higher salinities in the Delta in summer 2014. Neither BO allowed for transfers under these conditions.

14

15

16

17

18

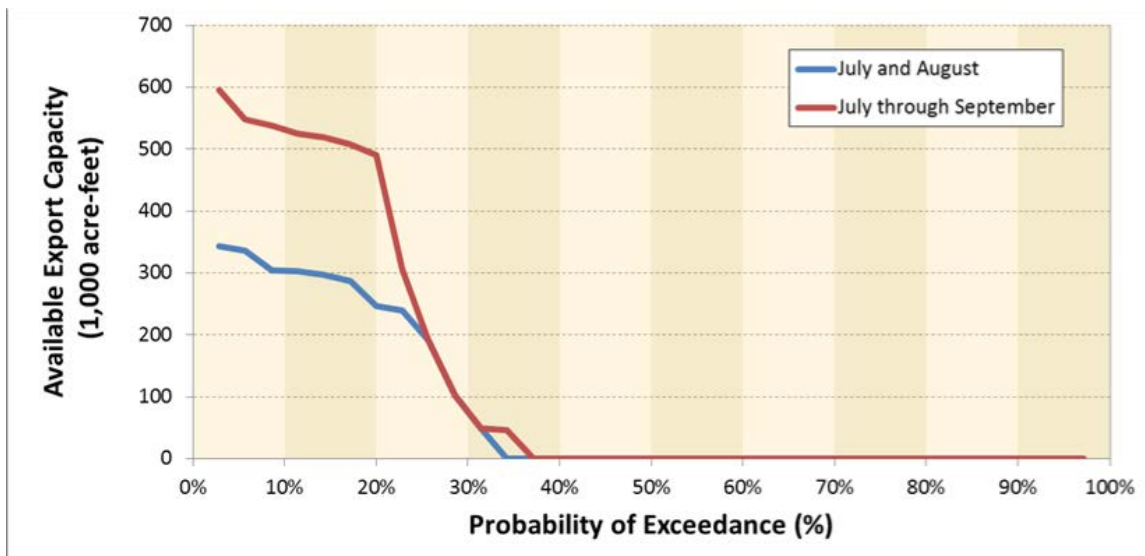

F. Reclamation has not followed its own rules

1. • *Transfer may not cause significant adverse effects on Reclamation’s ability to deliver CVP water to its contractors.*

In 2014 Reclamation had to release more water than expected to meet export demands including transfers. The unplanned release of “extra” Shasta and Folsom storage water adversely affects Reclamation’s ability to meet its contractual demands and permit requirements. For example, North-of-Delta contractors were initially threatened with a 40 percent allocation that was later changed to 75 percent delivery.

19

2. • *Transfer will be limited to water that would be consumptively used or irretrievably lost to beneficial use.*

Water diverted from the Delta is not water that would be consumptively used; it is water that would have eventually move to San Francisco Bay.

20

3. • *Transfer will not adversely affect water supplies for fish and wildlife purposes.* Transfers results in storage levels lower than predicted, which limit cold-water pools and the ability to maintain downstream “fish flows”.

21

4. • *Transfers cannot exceed the average annual quantity of water under contract actually delivered.*

The amount of CVP storage necessary to meet transfer export demands may be double the contracted amount.

22

G. Comments on Impact Statements in the EIR/EIS

1. *“Water supplies on the rivers downstream of reservoirs could decrease following stored reservoir water transfers, but would be limited by the refill agreements”.*

The whole subject of “refill agreements” is not adequately covered by Reclamation. The fact that it may take several years or more to refill is a significant effect not addressed.

23

2. *“Water transfers could change reservoir storage in CVP and SWP reservoirs and could result in water quality impacts.”* No information as to the specific effects on Shasta, Trinity, or Folsom reservoir storage or downstream tailwater flows was provided.

24

3. *“Water transfers could change reservoir storage non-Project reservoirs participating in reservoir release transfers, which could result in water quality impacts.”* The effect on reservoir and tailwater water quality in non-refill years of multiyear droughts was not addressed.

25

4. *“Water transfers could change river flow rates in the Seller Service Area and could affect water quality.”* Effects on specific rivers and reaches were not addressed.

26

5. *“Water transfers could change Delta outflows and could result in water quality impacts.” “Water transfers could change Delta salinity and could result in water quality impacts.”* Specific effects on Delta water temperature, salinity, and turbidity in drought years like 2014 were not addressed.

27

6. *“Transfer actions could alter hydrologic conditions in the Delta, altering associated habitat availability and suitability”* Specific effects of transfers on Delta hydrology in drought years like 2014 were not addressed.

28

H. Specific Comments on Cumulative Impact Assessments in the EIR/EIS

“The cumulative analysis evaluates potential SWP transfers, but they are not part of the action alternatives for this EIS/EIR.” Given the difficulty of separating these actions and their effects, and that other environmental assessments and biological opinions address joint actions, we see no reason to not address the joint action of transfers through the Delta in this EIR/EIS, especially given the following EIR/EIS statement: *“Most of the pumping capacity available would be at the Banks Pumping Plant except for very dry years. Banks is an SWP facility, so SWP-related transfers would have priority. Agreements with DWR would be required for any transfers using SWP facilities.”*

29

Note: In 2013, DWR facilitated about 265 thousand acre-feet of water transfers through State Water Project facilities, nearly double the amount anticipated for CVP transfers.

http://www.water.ca.gov/watertransfers/docs/2014/Transfer_Activities_v11.pdf

I. Specific Comments on Section 3.7 Fisheries

1. *“Water transfers, which would occur from July through September, would coincide with the spawning period of winter-run Chinook salmon. However, spawning occurs upstream of the areas potentially affected by the transfers. Due in part to elevated water temperatures in these downstream areas during this period, emigration would be complete before water transfers commence in July.”* P3.7-12

30

Water transfers also come from Shasta storage releases. Downstream emigration of fry from spawning reaches near Redding commences in July and continues through September.

2. *“Summer rearing of CV steelhead would overlap with water transfers occurring in the Selder Service Area (July-September), both in the Sacramento and San Joaquin River and their tributaries (see specific tributaries listed above). Thus water*

31

transfers have the potential to affect steelhead. The majority of rearing, however, would occur in the cooler sections of rivers and creeks above the influence for the water transfers.” P3-7-14. The “majority” of rearing occurs in tailwaters, which would be affected by transfers (e.g., the lower American River tailwater below Folsom Reservoir).

31

3. *“(Delta smelt) Larvae and juveniles are generally present in the Delta from March through June. Delta smelt have typically moved downstream towards Suisun Bay by July because elevated water temperatures and low turbidity conditions in the Delta are less suitable than those downstream (Nobriga et al. 2008). Some delta smelt reside year-round in and around Cache Slough (Sommer et al. 2011). Delta smelt in Suisun Bay and Cache Slough would be outside of the influence of the export facilities.” P3-7-16. In dry and critical years, delta smelt reside primarily in the Delta in summer in the direct path of water moving across the Delta to South Delta export pumps (see Attachments A and B for details).*

32

4. Consistency of Section 3.7 with the provisions of the California Environmental Quality Act (CEQA) and the CEQA Guidelines. Section 3.7 concludes that all effects are less than significant (e.g., p37-37). Using CEQA criteria - *An alternative would have a significant impact on fisheries resources if it would:*

33

a. *Cause a substantial reduction in the amount or quality of habitat for target species. YES*

b. *Have a substantial adverse effect, such as a reduction in area or geographic range, on any riverine, riparian, or wetland habitats, or other sensitive aquatic natural community, or significant natural areas identified in local or regional plans, policies, regulations, or by CDFW, NOAA Fisheries, or USFWS that may affect fisheries resources. YES*

34

c. *Conflict with the provisions of an adopted HCP, NCCP, or other approved local, regional, or state habitat conservation plan. YES (Delta Water Quality Control Plan)*

35

d. *Cause a substantial adverse effect to any special-status species, – Have a substantial adverse effect, either directly or through habitat modifications, on any endangered, rare, or threatened species, as listed in Title 14 of the California Code of Regulations (sections 670.2 or 670.5) or in Title 50, Code of Federal Regulations. A significant impact is one that affects the population of a species as a whole, not individual members. YES (WINTER RUN, DELTA SMELT)*

36

e. *Have a substantial adverse effect, either directly or through habitat modifications, on any species identified as a candidate, sensitive, or special-status species in local or regional plans, policies, or regulations, or by CDFW, NOAA Fisheries, or USFWS, including substantially reducing the number or restricting the range of an*

37

endangered, rare, or threatened species. YES (WINTER RUN, DELTA SMELT)

37

f. Cause a substantial reduction in the area or habitat value of critical habitat areas designated under the federal ESA or essential fish habitat as designated under the Magnusson Stevens Fisheries Act. YES (WINTER, SPRING, FALL, LATE FALL RUN; STEELHEAD, GREEN AND WHITE STURGEON, DELTA AND LONGFIN SMELT)

38

g. Conflict substantially with goals set forth in an approved recovery plan for a federally listed species, or with goals set forth in an approved State Recovery Strategy (Fish & Game Code Section 2112) for a state listed species. YES, RECOVERY PLANS FOR CV SALMON, DELTA SMELT, AND LONGFIN SMELT.

39

3. ATTACHMENTS

A. Summer 2014 Water Transfers

Transfers were conducted in the summer of 2014 under a Finding of No Significant Impact NEPA document. Our review of the proposed 2014 transfers is presented in Attachment A.

40

B. Summer 2014

As background on the overall effect of summer transfers, we present an assessment of the overall effect on Delta Smelt in summer 2014 in Attachment B.

Thomas N. Lippe (Bar No. 104640)
LAW OFFICES OF THOMAS N. LIPPE APC
201 Mission St., 12th Floor
San Francisco, California 94105
Tel 415 777-5604 x 1
Fax 415 777-5606
E-mail: lippelaw@sonic.net

Michael R. Lozeau (Bar No. 142893)
Richard T. Drury (Bar No. 163559)
Douglas J. Chermak (Bar No. 233382)
LOZEAU DRURY LLP
410 12th Street, Suite 250
Oakland, California 94607
Tel: (510) 836-4200
Fax: (510) 836-4205
E-mail: michael@lozeaudrury.com
richard@lozeaudrury.com
doug@lozeaudrury.com

Attorneys for Plaintiffs AQUALLIANCE
and CALIFORNIA SPORTFISHING
PROTECTION ALLIANCE

**UNITED STATES DISTRICT COURT
EASTERN DISTRICT OF CALIFORNIA**

AQUALLIANCE, a non-profit corporation, and
CALIFORNIA SPORTFISHING PROTECTION
ALLIANCE, a non-profit corporation,

Plaintiffs,
v.

UNITED STATES BUREAU OF RECLAMATION,
a federal agency, RICHARD J. WOODLEY, in his
official capacity, LOWELL PIMLEY, in his official
capacity, and DAVID MURILLO, in his official
capacity,

Defendants.

) Case No.:
)
) DECLARATION OF TOM CANNON IN
) SUPPORT OF MOTION FOR PRELIMINARY
) INJUNCTION
)
) (National Environmental Policy Act, 42 U.S.C. §
) 4321 *et seq.*; Administrative Procedure Act, 5
) U.S.C. §§ 701 *et seq.*)

I, Tom Cannon, declare:

1. I am a specialist in assessing environmental effects on fish and their aquatic habitats. I have over 40 years of experience in this field along with degrees in fisheries, biology, and biostatistics. A true and correct record of my qualifications is attached hereto as Exhibit 1.

2. I have been retained by the Law Offices of Thomas N. Lippe to provide consulting and expert witness testimony regarding the potential effects on Delta smelt of the 2014 San Luis & Delta-Mendota Water Authority Water Transfers for which the Bureau of Reclamation has approved a Finding of No Significant Impact under the National Environmental Policy Act (“NEPA”).

3. My professional career has focused on estuarine fisheries ecology with experience in East Coast and West Coast estuaries including 25 years since 1977 relating to the Sacramento-San Joaquin Delta Estuary. From 1977-1980 I was project director of Bay-Delta ecological studies for PG&E's Bay-Delta power plants effects studies. From 1980-82, I was a consultant to the State Water Contractors, the National Marine Fisheries Service, and State Water Resources Control Board (“State Board”) determining the effectiveness of the 1978 Bay-Delta Water Quality Standards in protecting the Bay-Delta ecosystem and striped bass population. From 1986-1987, I was a consultant to the State Water Contractors and Bureau of Reclamation during the State Board hearings on water quality standards. From 1994-1995, I was a consultant to the State Water Contractors and the California Urban Water Agencies, working on the 1995 Bay-Delta Water Quality Standards and how the new standards would affect the Bay-Delta ecosystem and its fish populations. From 1995-2003 I was a consultant to the CALFED Bay-Delta Program where I worked on various teams assessing the effects of alternative Delta operations and water supply infrastructure. From 2002-2010, I was involved in activities related to the Striped Bass Stamp Program, Salmon Hatchery Program, and Delta fish surveys funded by the US Fish and Wildlife Service to assess the effects on Delta fish and habitats. In the past decade I have worked closely with the Fishery Foundation of California, the California Striped Bass Association, and the

California Sportfishing Protection Alliance (“CSPA”) on Delta science related issues including water quality standards and the Bay Delta Conservation Plan (“BDCP”). Most recently I have reviewed the effects of the various drought-related orders of the State Water Board and the potential effects of the State's 2014 Drought Plan on the Bay-Delta Estuary’s fish populations and habitats. I obtained a Master’s Degree in Biology from Northern Michigan University in 1971 and a Masters of Public Health degree in Biostatistics from the University of Michigan in 1972.

4. In 2013 I prepared an analysis of the effects of OCAP operations on Delta smelt for the CSPA. A true and correct copy of that analysis is attached hereto as Exhibit 2.

5. In May, 2014, I prepared, for Thomas Lippe, an attorney representing CSPA and AquAlliance, an analysis of the effects of OCAP operations with the addition of the Bureau of Reclamations’ 2014 San Luis & Delta-Mendota Water Authority Water Transfers (2014 Transfers) in combination with the State Water Resources Control Board’s May 2, 2014 relaxation of standards that govern Delta flow and water quality pursuant to Order D-1641. A true and correct copy of that analysis is attached hereto as Exhibit 3.

6. On June 9, 2014, I prepared, for Thomas Lippe, an analysis of the degree to which Delta outflow as measured and regulated by the state and federal agencies that govern Delta OCAP operations, grossly overestimates actual Delta outflow, with severe consequences for Delta smelt. A true and correct copy of that analysis is attached hereto as Exhibit 4.

7. The analyses contained in Exhibits 2, 3, and 4 represent my best professional judgment regarding the matters described therein, and the opinions expressed in these reports represent my current professional opinions.

8. Delta smelt occupy the area of the Delta known as the “low-salinity zone” (“LSZ”). The LSZ is located where fresh water flowing toward San Francisco Bay mixes with salt or brackish water. The LSZ is generally centered around the areas where salinity values equal 2 parts per thousand, a value

known as X2. In the summer months in normal or wet water years, normal Delta outflows keep the LSZ, and the Delta smelt population that lives in the LSZ, in the Western Delta, where water temperatures are suitable for Delta smelt and where they are far from the water export pumps located in the South Delta.

9. In my 2013 analysis (Exhibit 2), I conclude that (1) low Delta outflows caused the LSZ (and its population of Delta smelt) to move upstream into the Central and Southern Delta, where water temperatures are significantly higher than the Western Delta; (2) releases of warm water from reservoirs upstream of the Delta (primarily Lake Shasta) in late June caused water temperatures in July in the LSZ to reach temperatures lethal to smelt; and (3) as a result, Delta smelt suffered significant mortality.

10. In my May 2014 analysis (Exhibit 3), I conclude that the 2014 Transfers, in combination with the SWRCB's May 2, 2014 relaxation of standards that govern Delta flow and water quality will exacerbate a similar increase in Delta smelt mortality because, once again: (1) low Delta outflows will cause the LSZ (and its population of Delta smelt) to move upstream into the Central and Southern Delta, where water temperatures are significantly higher than the Western Delta, and where they are more vulnerable to entrainment in the export pumps; (2) releases of warm water for the Transfers from reservoirs upstream of the Delta (primarily Lake Shasta) in the transfer period (July through September) will cause water temperatures in the transfer period in the LSZ to reach temperatures lethal to smelt; (3) will cause or increase reverse OMR flows making it more likely that any surviving smelt will be entrained in the export pumps; and (4) as a result, Delta smelt will suffer significant mortality.

11. In my June 9, 2014, letter (Exhibit 4), I conclude that Delta outflows this summer will be much lower than expected or considered in the Bureau's environmental assessment for the 2014 Transfers because the standard governing Delta outflows (i.e., minimum 3,000 cfs Net Delta Outflow Index ("NDOI") for the transfer period) grossly overestimates actual Delta net outflow. As a result,

actual outflows will be close to zero or even negative. This has severe consequences for Delta smelt, because such low outflows exacerbate the conditions that make the standard of 3,000 cfs harmful.

42

12. The Bureau of Reclamation responded to my May 2014 analysis by letter dated May 30, 2014, which included comments provided from Ms. Frances Brewster, a hydrologist, and Dr. Erwin Van Nieuwenhuysse, a biologist. (A true and correct copy of this letter is attached hereto as Exhibit 5.)

13. These reviewers fail to address my main points: that transfers under relaxed standards increase the already high risk from low outflow and exports in summer of critical years when “all” smelt are in the Delta. The main risk is degrading critical habitat by increasing already high water temperatures. My analysis shows that already-critical water temperature will increase in critical habitat habitats of smelt with transfers. All locations in the LSZ will increase in water temperature to near or above critical levels. Thus, while the temperature increases may be small in relative terms, they are critical because temperatures will be near or at lethal levels even without the transfers and relaxation of standards.

43

14. The analysis of impacts of Delta water management operations on Delta smelt involves a number of causes of impacts that must be assessed in combination with each other, not in isolation, including reduced outflow and higher flow through the Delta from transfers. There are also a number of impacts on smelt habitat from these causes, all of which interact with each other. These include higher water temperature, reverse OMR flows, more upstream location of the LSZ, and reduced food availability. My analysis includes all of these variables.

44

15. Ms. Brewster, in contrast, selects four values that are not germane to my analysis, and discusses each one in isolation, rather than in combination. Therefore, her conclusions are non-responsive.

16. **Temperature.** Ms. Brewster presents data showing that average temperature in the entire three-month transfer period is .5 degrees F higher in the Sacramento River at Rio Vista than at

45

Emmaton. This is the wrong metric for purposes of analyzing the Transfers' impact on Delta smelt. The issue is not whether the transfers under relaxed outflow standards will cause a large average difference, over a 3 month time period, between temperatures at Emmaton and Rio Vista. The issue is whether the transfers under relaxed outflow standards will cause a large enough difference in temperature to kill smelt at any time as compared to either not doing the transfers or doing them under normal outflow standards.¹

17. The U.S. Fish and Wildlife Service determination that Delta smelt warrant designation as "endangered" states: "Delta smelt tolerate temperatures ranging from 7.5 C to 25.4 C (45 to 78 F) in the laboratory (Swanson et al. 2000, p. 386, Table 1)" (Federal Register, Vol 75, No. 66., p. 17668.) Bennet's peer reviewed study states: "Water temperatures over about 25°C [77°F] are also lethal, and can constrain delta smelt habitat especially during summer and early fall (Swanson and others 2000). Overall, the majority of juveniles and adults in the TNS and MWT have been caught at water temperatures less than 22°C [71.6°F] (Figure 5)." ("Critical assessment of the delta smelt population in the San Francisco Estuary, California" (2005), William A. Bennet, John Muir Institute of the Environment, Bodega Marine Laboratory, University of California, Davis.) Among biologists, seventy-seven (77) degrees F is a commonly accepted lethal temperature for smelt. In my opinion, prolonged exposure to temperatures above seventy-five (75) degrees F is stressful to smelt.

18. In my 2013 analysis, I reported that temperatures in late June and July of 2013 reached lethal levels around July 5 in some locations and near-lethal temperatures for a prolonged period of time in many locations. The following table summarizes the data I presented in my 2013 report.

¹ As the U.S. Fish and Wildlife Service has explained, "Since 1978, delta smelt have become increasingly rare in summer and fall surveys of the San Joaquin region of the San Francisco Bay-Delta (Nobriga et al. 2008, p. 9). The primary reason appears to be the comparatively high water clarity in the region, although high water temperatures are also likely a contributing factor (Nobriga et al. 2008, pp. 8, 9)." (Federal Register, Vol 75, No. 66., p. 17669.)

Location	Temperature above 75°F	Temperature above 77°F
Emmaton	June 30- July 11	peaked at 76.9 on July 4
San Joaquin River at Antioch	July 1- 7	peaked at 76.69 on July 2
San Joaquin River at Jersey Point	June 30- July 11	peaked at 76.75 on July 5
Three Mile Slough at Joaquin River	July 1- 11	July 5
False River	June 30- July 7	July 3-5
Bacon Island at Old River	June 27- July 17	June 29-July 14
Clifton Court Forebay	June 27- July 31	June 29-July 15
Middle River at Middle River	June 27- July 31	June 29-July 17, July 24-27
Staten Island	June 27- July 15	July 1- July 10

This data shows that a half-degree increase in temperature is potentially very significant because temperatures are likely to be in the near-lethal to lethal ranges in the LSZ even without transfers and/or relaxed standards. This data also shows that using the small (but potentially significant) difference in the three month average temperature at Emmaton and Rio Vista as a metric for the Transfers' harm to smelt is not useful for predicting impacts on smelt.

19. **Entrainment.** Ms. Brewster argues that the 2008 Smelt BO does not have OMR reverse flow limits in the transfer period and that reverse OMR flows can be as high as -8000 cfs in a “typical year.” These facts are irrelevant to what is happening in the summer months of dry and critically dry years (*i.e.*, 2013 and 2014) because, in a typical year, the LSZ is in the Western Delta, where water temperatures are suitable for Delta smelt and where they are far from the water export pumps located in the South Delta. One of my key points is that the 2008 Smelt BO fails to address what is happening in

the summer months of dry and critically dry years, especially under relaxed D-1641 outflow conditions. Indeed, the USFWS has conceded this point.²

20. **Smelt Food.** Ms. Brewster does not disagree with my opinion that “transfer flows will displace plankton rich, higher turbidity water with plankton poor, low turbidity water.” Instead, she asks how this phenomenon differs from normal Delta operations. The USFWS has found that “normal” Delta operations are a significant reason Delta smelt are a “threatened” species and that the “endangered” designation is warranted.³ Ms. Brewster looks at this variable in isolation, rather than in combination with other effects of the transfers under relaxed D-1641 standards. Specifically, doing the transfers under relaxed outflow standards will cause the LSZ where smelt live to be closer to the pumps than they would be in a “normal” year.

21. **LSZ Area.** Ms. Brewster argues that the area of LSZ is “essentially the same” whether X2 is at Emmaton or Three-mile Slough. This is a red herring, because my opinions are primarily based on the changed *location* of the LSZ, not its smaller areal extent.

² “Although the proposed departure from D-1641 was not anticipated in the Project Description of the BiOp, or the modeling in the biological assessment, the proposed relaxations, based on the provisions provided in the TUC Order, as amended, and existing hydrologic and biological conditions for the months of April and May appear to be within the range of effects previously analyzed in the 2008 BiOp. The Service, therefore, concurs with Reclamation's determination that the proposed modifications for April and May will have no additional adverse effects on delta smelt or its critical habitat. ¶ The Service cannot, however, concur at this time with Reclamation's determination that the proposed Plan will have no additional adverse effects on delta smelt or its critical habitat for the remainder of the project time period, June 1 through November 15, 2014.” (USFWS, April 8, 2014, p. 8, attached hereto as Exhibit 2 (emphasis added).)

³ “Based on a review of the best scientific and commercial information available, we find that destruction, modification, or curtailment of habitat poses a current and future threat to delta smelt. Operation of upstream reservoirs, increased water exports, and upstream water diversions have altered the location and extent of the low salinity zone, concentrating smelt in an area with competing fish species. Upstream reservoirs and the increased presence of *Egeria densa* have also reduced turbidity levels in rearing habitat, which may reduce foraging efficiency.” (Federal Register, Vol 75, No. 66., p. 17669.)

22. Nevertheless, since Ms. Brewster has focused attention on this value, it is worth noting that using her “Figure B-1,” it appears that when X2 moves from Emmaton (at about mile point 90 on the x-axis) to Three-mile Slough (at about mile point 93 on the x-axis), the LSZ loses about 10% of its area (i.e., about 500 of 4,500 hectares). Ms. Brewster suggests no reason, and certainly no biological reason, that 4,000 hectares is “essentially the same” as 4,500 hectares for purposes of assessing impacts on smelt.

50

23. Dr. Nieuwenhuysse apparently agrees with me that in the coming summer months the LSZ is going to be uninhabitable by smelt due to high temperatures and lack of food. Dr. Nieuwenhuysse suggests that this new state of affairs will not cause harm to smelt because they can find temperature and food refuge in the Sacramento Deepwater ship channel upstream of Rio Vista. I am aware of no scientific basis for this assertion. The U.S. Fish and Wildlife Service’s 2008 Smelt Biological Opinion does not suggest that the Sacramento Deepwater ship channel upstream of Rio Vista provides a viable temperature and food refuge for Delta smelt when their only recognized habitat – the LSZ in the Delta – has been rendered unsuitable for their survival by the Bureau’s water management decisions.

51

24. In my opinion, the effect of Delta operations this summer of confining smelt to the Sacramento Deepwater ship channel upstream of Rio Vista due to adverse environmental conditions in the LSZ that will be exacerbated by the Transfers, both with and without relaxed outflow standards, with no evidence that they can emerge from the ship channel in the fall to produce another generation of smelt, is significant new information showing that the Transfers will have significant adverse impacts on Delta smelt.

52

I declare under penalty of perjury that the forgoing is true and correct of my personal knowledge.
Executed this 10th day of June, 2014, in Fair Oaks, California,



Tom Cannon

EXHIBIT 1

Resume of Thomas C. Cannon

Aquatic Ecologist
5161 Oak Shade Way
Fair Oaks, CA 95628
916-988-1291 home
916-952-6576 cell
tccannon@comcast.net

EDUCATION:

University of Michigan
Fall 1965 – Summer 1969
School of Natural Resources
Major: Fisheries and Aquatic Ecology
B.S. in Fisheries

Northern Michigan University
Fall 1969 – Spring 1971
Biology Department
Majors: Biology and statistics.
M.A. in Biology

University of Michigan
Fall 1971 – Spring 1972
School of Public Health
Majors: Biostatistics and Environmental/Public Health
Masters of Public Health in Biostatistics

AFFILIATIONS:

American Fisheries Society (AFS)
CAL-NEVA Division of AFS
Fishery Foundation of California
California Sportfishing Protection Alliance

Relevant Experience:

- **Hudson River Power Plant NPDES Permit Projects – Hudson River Utilities
New York (1972-1977)**

Early in my career I participated in some of the earliest projects developed under NEPA. Most notably I participated in studies related to the continuing operations of Hudson River power plants as related to environmental impacts to Hudson River biota with emphasis on fish and water quality. I managed projects and staff, and designed and

carried out studies, analyzed data, assessed impacts, and prepared reports and NPDES permits for all major power plant complexes on the Hudson River. I participated in the related NEPA process for licensing of the Indian Point Nuclear Power Plant for the Atomic Energy Commission and Federal Power Commission.

- **Great Lakes Power Plants NPDES Permits – Detroit Edison (1976-1977)**

I managed a project preparing NPDES permit applications for all of Detroit Edison's electric generating stations on the Great Lakes.

- **PG&E Delta Power Plant NPDES Permit Project – PG&E (1977-1980)**

I managed a project preparing NPDES permit applications for all of PG&E's steam-electric generating stations in California. The project included extensive surveys of the Bay-Delta and power plant impacts on the environment. Studies were coordinated closely with the DFG and federal agencies. Studies were coordinated with the NMFS (Tiburon Office), USFWS, and the Regional Water Quality Control Boards. One of my primary responsibilities was coordination with resource and regulatory agencies.

- **Striped Bass Project – SWRCB (1981-1982)**

I was a member of the State Board's Striped Bass Project team in the early 1980's investigating the failure of the water quality control plans in halting the precipitous decline in the striped bass and other fishes of the Bay-Delta. Our chief objective was to determine whether Delta and other diversions were directly causing loss of fish through entrainment or whether there was a fundamental shift in ecosystem productivity and habitat quality that was the cause of the declines in fish populations. We identified in our report to the State Board that regardless of the cause, the D-1485 Delta standards were inadequate to protect the Bay-Delta ecosystem and important fish populations including salmon and striped bass.

- **Importance of Bay-Delta as Nursery Area for Chinook Salmon – NMFS (1981-1982)**

As a consultant to the NMFS, I conducted a review of the importance of the Bay-Delta as a nursery area for Chinook salmon and other anadromous fishes including striped bass.

- **South Fork of the American River (SOFAR) Project (1981-1982)**

As a consultant to the project developer, my engineering firm was involved in the design of the SOFAR projects. My role included preliminary permitting and agency interaction.

- **Forest Management and Timber Harvest Plan – Hoopa Indian Reservation for BIA (1982)**

As a consultant to the BIA, I participated in the development of a Forestry Management Plan for the Hoopa Indian Reservation in northern California. I evaluated potential effects of all forest management activities on salmon and steelhead and their habitat in the Klamath and Trinity Rivers, and in tributaries to those rivers on tribal lands affected by forest management activities. I spent two weeks on the reservation with reservation and BIA staff observing potentially effected habitats and planned timber management activities. During that time I became acutely aware of the growing conflict between BIA

managers and the tribes over control over reservation resources. I developed portions of the plan outlining protections to salmon and their habitat from forest management activities.

- **Alaska Oilfields Environmental Studies – ARCO/USACE (1982-1986)**

As project manager of NEPA mandated environmental programs for oil companies and the Alaska District USACE, I coordinated environmental studies that addressed environmental impacts of oil field operation on the tundra and coastal river, estuarine, and marine ecosystems. Major focus was on effects to anadromous fish and their habitat from environmental impacts allowed under USACE permits. I worked closely under the direction of an interagency oversight team to evaluate impacts, conduct monitoring programs, and to define mitigation measures for North Slope oil operations. I also coordinated with North Slope native organizations from Point Barrow to the McKenzie River in Canada. I prepared for and presided over dozens of interagency and stakeholder meetings and technical workshops, and prepared reports and scientific papers.

- **Effects of Delta Pumping Plants on Bay-Delta Ecosystem – State Water Contractors and MWD – (1981-1987)**

As a consultant to the State Water Contractors and the Metropolitan Water District, I evaluated potential effects water projects in the Central Valley. My assignments included evaluating effects of CVP operations on the American River including review of early Instream Flow Incremental Methodology studies. I participated in many interagency reviews and worked closely with DWR and DFG staff working on a Draft Two-Agency Agreement for the State Water Project. I also worked with the USBR on testimony for the 1986 Water Quality Control Plan hearings with the State Water Resources Control Board.

- **Columbia River Data Development Project – BPA (1981-1984)**

As a consultant to the Bonneville Power Authority, I participated in a comprehensive study of the Columbia River estuary. My role was as an estuarine ecologist with emphasis on fish populations and the food chain. Working with agency and university biologist, our team developed baseline information on the Columbia River Estuary and its role in salmon ecology.

- **Susitna Hydroelectric Project – Alaska Power Authority (1984-1985)**

As a consultant to the Alaska Power Authority, I participated in the process of obtaining a FERC license for a hydroelectric dam on the Susitna River in south-central Alaska. Large scale changes in river flow, sediment and water temperature regimes, and geomorphology of the river from the proposed dam indicated to all involved that major impacts to the many salmon populations of the river could be expected if the dam were built. Eventually a lack of need for power killed the project. The project allowed me for to work with engineers, hydrologists, geomorphologists, groundwater, sediment, and water quality specialists to evaluate proposed effects of development on an ecosystem scale.

- **FERC Snake River Projects (1986-1989)**

As a consultant to Federal Energy Regulatory Commission (FERC), I participated in the NEPA process and preparation of federal EIS's relating to the licensing and relicensing of hydroelectric projects on the Snake River in Idaho. My role was to develop sections on aquatic species and habitats, and to coordinate Section 7 consultations with federal and state agencies review teams. Protected species at the time included bald eagles and several aquatic snail species. Rare and isolated populations of cutthroat trout were also addressed. I was responsible for addressing state and local land use laws and plans. Instream flow requirements for the Snake River were fundamental issues. This was one of several major FERC projects in which I was involved where state water law and the ESA were in direct conflict.

- **USFS/FERC Skagit-Nooksack Project (1988-1989)**

Working as a consultant to the US Forest Service, I participated in the NEPA process for multiple hydropower licensing and relicensing projects for the Forest Service and FERC. Actions evaluated included changes to flow and stream habitats. Effects considered included those on sockeye salmon and bull trout, as well as Coho and Chinook salmon and steelhead populations of the Skagit and Nooksack rivers.

- **FERC Elwha Project (1988-1990)**

I participated in the NEPA process relating to the relicensing or termination of FERC licenses for two dams on the Elwha River in Washington. I evaluated the potential impacts and benefits to salmon, steelhead, and bull trout populations from various alternatives including dam removal.

- **BPA Cowlitz Falls Project (1988-1990)**

I participated in the environmental documentation for the Cowlitz Falls Project of the City of Tacoma Washington for BPA. Actions included reintroduction of anadromous salmon and steelhead to the Cowlitz River and its tributaries above existing large hydroelectric project dams and reservoirs. Concepts and alternatives developed and evaluated including trucking adult salmon and trout above reservoirs and capturing young salmon and steelhead on their downstream migration before they reached the reservoirs, and transporting them below the lower dam on the Cowlitz River. The project is one of the most successful attempts at reintroducing anadromous fish to headwaters of dammed river.

- **FERC Salt Caves Project (1989-1991)**

As a consultant to FERC, I participated in the FERC licensing project for the Salt Caves Project on the Klamath River on the border of California and Oregon. I evaluated environmental effects of alternative hydropower generation facilities on resident trout, endangered suckers, and other aquatic life of the Klamath River. The evaluation included potential effects to anadromous salmon and steelhead of the project in the event that passage was restored past downstream dams (Irongate and Copco 1 and 2). I participated in Section 7 consultations relating to bald eagle and endangered suckers. I reviewed recovery plans and actions relating to the project that could impact or benefit these

species. The primary laws and regulations governing potential project operations were those of the state of Oregon. The project was eventually not licensed by FERC because it failed to meet state water quality standards. I helped coordinate and conduct public meetings in Klamath Falls.

- **FERC Platte River Project (1990-1992)**

As a consultant to FERC, I participated in FERC licensing and related NEPA process for the Platte River Project in Nebraska. I evaluated potential effects to resident fishes, as well as special status species including paddlefish, sturgeon, whooping cranes, Arctic terns, and piping plovers - fish and birds that would be potentially affected by flow and habitat changes relating to the relicensing of the hydropower project. The Platte River Project supplied much of the agricultural water supply of central Nebraska. FERC jurisdiction and endangered species protection mandates brought project water supply objectives into direct conflict with ESA. On this and other FERC projects my team served as an extension of the FERC staff and often operated as “FERC staff” in coordinating with federal, state, and local entities, in conducting public meetings, and in preparing documentation. I presided over public meetings and technical coordinating meetings with federal, state, and local agencies, as well as stakeholders including environmental groups. Working with engineering staff I helped develop water supply and hydrology models of the Platte River. Key technical issues including land use, stream flows, and water supply were discussed and agreements worked out.

- **USACE Missouri River Master Manual Review (1991-1994)**

As a consultant to the Missouri River Division of the USACE, I spent several years developing and evaluating alternatives and preparing an EIS on alternative Master Manual Operation regimes for the Missouri River dam-reservoir system from eastern Montana to the mouth of the Missouri River. My role focused on developing alternatives and assessing effects on environmental and cultural resources including special status species such as sturgeon and paddlefish. Effects considered were to reservoir water levels, stream flows, and related effects on water quality. The project included coordination with the many tribes along the Missouri River. Many of the tribes had keen interests in recreation, water supply, cultural, and water quality issues. I prepared for and presided over public meetings and technical workshops.

- **USACE/BPA Columbia/Snake Operations Review (1992-1994)**

I participated in the Columbia/Snake Operations Review for the USACE Walla Walla District, BPA, and USBR. I worked on elements of the EIS and potential effects to project alternatives to salmon and steelhead populations of the Columbia and Snake River systems.

- **BPA/Clearwater Indian Nation Clearwater River Study (1993-1994)**

I participated in IFIM and hydrology studies on the Clearwater River to evaluate changes in flow on salmon and steelhead and their habitat on the Clearwater River in southwestern Idaho. We worked through the tribes who received grants from BPA.

- **Bay/Delta Ecosystem Effects Studies – MWD (1994-1995); CUWA (1996)**

As a consultant to the Metropolitan Water District of Southern California and the California Urban Water Agencies, I was part of a team planning development of a multispecies habitat conservation plan for the State Water Project. I was also assigned to evaluate and help improve the IEP Monitoring Program in the Bay-Delta working closely with DFG, DWR, and USBR staff. I participated in many interagency review meetings and technical workshops on the operations of the state and federal water projects.

- **PG&E Delta Power Plants HCP and EA (1997-1999)**

As a third-party consultant funded by PG&E and representing the USFWS and NMFS, I participated in the preparation of an HCP and EA for a Section 10 application to take winter-run Chinook salmon and delta smelt at two Delta power plant complexes. I evaluated the long-term effects of the facilities and future operations on Delta and anadromous fish populations. I helped prepare the HCP and EA submitted by PG&E. I met with state and federal ESA agency staff on numerous occasions to discuss conservation measures and the effects of the facilities. I also evaluated potential conflicts between the NPDES and Section 10 permits for the facilities, as well as potential for greater diversions and higher temperature thermal plumes from the plants under the new ownership and ISO/IPO system being implemented by the California Energy Commission.

- **Delta Wetlands Project – BA and ER (1996-1998)**

As a third-party consultant funded by Delta Wetlands and representing the State Board and USACE, I participated in the development of alternatives and their environmental impact evaluations for the Delta Wetlands Project in the Sacramento-San Joaquin River Delta. I participated in the evaluation of potential effects of new water diversions on Delta outflow and evaluated implications to salmon, steelhead, and delta smelt populations. I also evaluated the potential to violate water quality criteria in the Delta from island storage releases. I participated in Section 7 consultations for the project with State and federal agencies while representing the applicant, the State Board, and USACE.

- **Montezuma Wetlands Project – BA and EIR/EIS (1996-1998)**

As part of a third-party consulting team funded by the applicant and representing Solano County and the USACE, I participated in the NEPA process related to the Montezuma Wetlands Project in Suisun Marsh near Collinsville. My roles included preparation of EIS sections on potential effects and benefits to fish and their habitat in the Bay-Delta, including winter run chinook salmon and delta smelt. Our team worked with the San Francisco District of the USACE and Solano County to ensure we met the needs of these permitting agencies.

- **Lower Butte Creek Study Program – Nature Conservancy and Ducks Unlimited (CVPIA program) (1997-1999)**

As a consultant to the Nature Conservancy and Ducks Unlimited I participated in the Lower Butte Creek Study Program to evaluate potential means for improving salmon and steelhead passage through the Butte Creek system. My role was to evaluate potential fish passage problems and help to identify and promote solutions through working with local

stakeholders. I identified passage solutions and previously unforeseen problems facing downstream salmon and steelhead juveniles migrating from spawning areas in the upper watershed. The Butte Creek system has tremendous obstacles to downstream migration of young salmonids particularly in drier years – most of these problems have yet to be resolved. My activities brought me in contact with local stakeholder groups, primarily farmers, but also federal and state refuge managers who also depend on water and land for their waterfowl and wetland programs.

- **Butte Creek Parrot-Phelan Dam Project – Butte County (1998-1999)**

As a consultant to Butte County I evaluated the final facilities constructed to replace facilities lost at the Parrot-Phelan diversion site from devastating floods. The facilities were constructed under emergency authorities and Butte County asked me to review the project to ensure it was constructed appropriately under their laws and responsibilities. I noted that the screen and ladder were well designed and worked well. I noted potential problems with the flood flow bypass and associated problems for upstream passage under high flows.

- **CVPIA and CALFED EIR/EIS's – USBR/CALFED (1995-1999)**

I participated in the preparation of the EIR/EIS's for the CVPIA and CALFED programs for the USBR and CALFED. The EIS's covered many actions under the CVPIA and CALFED programs including alternatives development and evaluation. I worked on the water management strategies for both programs including the Environmental Water Account. I have worked extensively on all elements of the CALFED program and many elements of the CVPIA program. This experience has made me acutely aware of water management in the Central Valley. My previous experience with problems relating from D-1485 water quality standards, proposed D-1630 standards, and the 1995 Accord and Standards fits in well with my recent experiences dealing with conservation and recovery of fish populations in the Central Valley. I also with the Anadromous Fish Restoration Program in the evaluation of the AFRP flow recommendations for the lower American River.

- **CALFED Ecosystem Restoration Program Plan – CALFED (1995-2000)**

As a consultant to CALFED, I was one of the original designers and authors of the Ecosystem Restoration Program Plan (ERPP). I prepared individual sections on actions to be considered for specific watersheds and resources including special status fish species. One of the major features of the ERPP is its links to other ecosystem restoration programs. I participated in various watershed reviews including the American River and was the author of the draft vision for the American River. I participated in the planning and conduct of many of the CALFED meetings and workshops.

- **CALFED Conservation Strategy - (1998-2000)**

I participated in the early design and development of the CALFED Conservation Strategy developed in consultation with a team of consulting scientists. I prepared early drafts of CALFED's Adaptive Management philosophy. I worked extensively on CALFED's Multi-Species Conservation Strategy. I was the principal author of appendix plans that

included many prescriptions for conservation and recovery of all special status fish species in the Central Valley. I reviewed listing documents and recovery plans and incorporated elements into the conservation actions. I reviewed all salmon conservation and recovery actions for the Central Valley and Pacific Coast and made recommendations for modifying and adding to the overall recovery program. I also developed conservation schemes and measures for potential effects of each of the CALFED Program elements and associated actions that could affect special status fish species.

- **Delta Fish Facility Advisory and Technical Teams – CALFED/ CVP (1999-2001)**

I participated as a consultant to Delta fish facilities teams evaluating intake and fish protection facilities at the Delta Cross Channel, proposed Hood diversion, Clifton Court Forebay, and Tracy Fish Protection Facilities. As a consultant to the CALFED Delta Entrainment Effects Team, I helped in evaluating the potential effects of many options for water diversion from the Delta, including potential effects to salmon and steelhead. I prepared papers on factors affecting salvage numbers of salmon and steelhead at the state and federal pumping plants in the South Delta.

- **CVPIA Comprehensive Assessment and Monitoring Program (CAMP) – (1995-1996)**

I was an original member of the CAMP consulting team. We developed a monitoring and assessment program to evaluate whether objectives of the CVPIA would be met, particularly goals to double salmon and steelhead runs in the Central Valley. I promoted development of monitoring and assessment techniques to estimate production of wild smolts as well as adult escapement.

- **CALFED Water Management Strategy and Environmental Water Account – (1998-2001)**

I participated in CALFED's development of a water management strategy including the Environmental Water Account that would protect and enhance survival of salmon. The water management evaluation included detailed review of operations of the American River Project on flows of the American River and Delta inflow. I participated in the inter-agency gaming exercise to evaluate alternative operations of the water projects in combination with CVP and CALFED water accounts. During two years of extensive exercises I became very familiar with water project operations in the Central Valley.

- **CALFED Delta Entrainment Effects Team – (1998-2000)**

I participated as an analyst on the CALFED DEFT team to evaluate the effects of water diversions on Bay-Delta fish populations.

- **CALFED DCC-TDF – (2000-2002)**

I participated in CALFED's Delta Cross Channel and Through Delta Facility team as an analyst to evaluate the benefits and adverse effects of different operations of the Delta Cross Channel and the proposed Through Delta Facility.

- **Water Forum/EBMUD – (1997-2000)**

As a consultant to the Water Forum (EBMUD) and SAFCA I participated in the evaluation of the alternatives for American River flow and flood management and river restoration. I also helped prepare Lower American River Floodway Management Plan for SAFCA. I participated in numerous Lower American River Task Force meetings and other related meetings including the Lower American River Operations Group and Management Group. I participated in the preparation of the EIR for EBMUD's and Sacramento County's water diversion from the lower American River (since moved to Freeport on the Sacramento River). I worked on SAFCA restoration projects along the lower river and participated in temperature studies from Lake Natomas downstream through the river. As a consultant to the East Bay Municipal Utility District, I attended Water Forum public meetings and advised EBMUD on issues relating to water and habitat that would affect salmon and steelhead of the lower American River prior to the Water Forum Agreement of 2000. I participated in teams evaluating potential salmon habitat conservation and improvement projects for the lower American River. I was the principal author of SAFCA's fish habitat section of the Lower American River Floodway Management Plan. As part of that project I evaluated numerous options for conserving and improving salmon and steelhead habitat throughout the lower American River. I consulted with EBMUD to evaluate proposed conservation and habitat improvement measures of the Water Forum for the lower American. I prepared and submitted grant proposals to CALFED on behalf of SAFCA for specific habitat improvements to the lower American River. I evaluated effects of operations of USBR on the lower American River salmon and steelhead habitat and populations.

- **GCID Sacramento River Project – USACE (1999)**

I participated in the design of a monitoring program to evaluate the effectiveness of mitigation measures and project fish protection elements for the new GCID intake facility on the Sacramento River.

- **Battle Creek Hatchery Screening Project – USBR (2000)**

I participated in the design of a monitoring program to evaluate the effectiveness of new fish screens at the Battle Creek hatchery intake system on Battle Creek.

- **Yolo Bypass Ecosystem Restoration Strategy Development Project - Yolo Basin Foundation (1999)**

Working with the Yolo Basin Foundation, I prepared a grant application for local stakeholders to develop a restoration strategy to restore wildlife and fish habitat and improve salmon survival through the Yolo Bypass. I spent many hours in the bypass from the Fremont Weir in the North to the exit of the bypass on Cache Slough observing habitat conditions, land use patterns, and potential obstructions to salmon upstream and downstream passage. I identified many potential problems and opportunities to improve habitat and passage for Sacramento River salmonids. I met with individual stakeholders (including DWR and PG&E Properties) and helped obtain their support for the project. The project was funded and has begun.

- **Upper Yuba River Studies Program – CALFED (2000-2001)**

As a consultant to CALFED, I participated in the Upper Yuba River Studies Program. I prepared a monitoring program design to collect information necessary to determine if the upper watershed above Englebright Dam has habitats adequate for anadromous salmon and steelhead. I participated in CALFED workshops with participating stakeholders and the general public.

- **Lower Yuba River Studies Program – YRTWG (2000-2001)**

I have supported the Yuba River Technical Working Group in the preparation of grant applications to study fish passage problems in the lower Yuba River at Daguerre Dam. I supported the Working Group in reviewing the USACE preliminary study of Daguerre Dam. Options being evaluated are dam removal and ladder improvements.

- **Yuba River Watershed Assessment – Yuba Watershed Council, South Yuba River Citizens League (2000-2002)**

I have supported Yuba River watershed stakeholder groups in preparing grant applications for federal and state funding for watershed assessment and restoration activities. I have attended meetings with the Yuba Watershed Council and the South Yuba Citizens League. I have taken many field trips to the watershed and have identified problems including high sediment loads that threaten production of salmon and steelhead in the lower river.

- **Mokelumne River Watershed Assessment – Sierra Pacific Industries (2000-2001)**

As a consultant to Sierra Pacific Industries, I participated in the development of a watershed assessment for the upper Mokelumne River watershed properties of Sierra Pacific. The assessment focused on potential risks to water quality, sediment/erosion, and water supply from timber harvest in the watershed. We identified sub-watersheds that had the greatest potential impacts from timber harvest and identified measures to reduce environmental damage.

Recent Employment

- **Jones and Stokes Associates – Sacramento (1995-1999)**

At JSA I participated in numerous local and regional projects including those identified above for this time period. I also received considerable management training as well as environmental training and classes on CEQA/NEPA and CESA/ESA. I managed JSA's contracts with CALFED and participated in CALFED's consulting team.

- **Foster Wheeler Environmental – Sacramento (1999-2002)**

At Foster Wheeler I was primarily responsible for developing environmental business in northern California, Idaho, Washington, and Alaska, in addition to the pursuit of local projects identified above.

- **Fishery Foundation of California (2002-present)**

As the executive director (2002-2003) and principal investigator of the non-profit Fishery Foundation of California I helped conduct a striped bass tagging study, striped bass pen

rearing program, and hatchery salmon acclimation program, and conducted a monitoring study of Delta fish habitat at Kimball Island near Antioch. I coordinated numerous activities with California Striped Bass Association and other sportfishing groups. I managed development and implementation of monitoring surveys of SAFCA habitat restoration projects in the LAR. I was the principal investigator of CVPIA monitoring surveys of the LAR that involved determining the habitat requirements of salmon and steelhead. I coordinated with stakeholder and agency groups and participated in workshops and projects including the Lower American River Corridor Management Plan. I have become intimately familiar with the river's hydrology, water temperature regime, salmon and steelhead populations, spawning and rearing habitat, and recreational fisheries. I was project manager and principal investigator on a grant from CVPIA to study water supply opportunities for the Cosumnes River. I was a consultant to Lake Wildwood Homeowners Association in proceedings with the Regional Water Quality Control Board and DFG Region 2 on water quality control plan violations in the Deer Creek watershed, a tributary to the lower Yuba River.

- **HDR Engineering – Folsom (2003-2004)**

At HDR I was primarily responsible for developing environmental business in northern and southern California, in addition to the pursuit of local projects identified above. I also participated in water resources projects in Alaska and Nebraska. I was project manager for regional indefinite deliverable contracts I helped procure for HDR with CALTRANS. I participated in many local and regional HDR projects working closely with the water resources engineering department.

- **Wildlands Inc. - Rocklin (2004-2010)**

As manager of aquatic programs at Wildlands during the past decade I developed habitat restoration programs for Central Valley rivers under federal and state mitigation banking programs. I have worked closely with DFG, NMFS, USFWS, DWR, and SAFCA in defining opportunities for riparian and floodplain restoration. I have participated in Lower American River meetings and workshops. I have worked closely with NMFS in the development of a Conservation Banking Program in the Central Valley for listed salmonid fishes. I developed longfin smelt and Delta smelt conservation banks in the Delta and Suisun Marsh.

- **Consultant (semi-retired) (2010-present)**

Consultant on fishery ecosystem assessment programs relating to California resource management. Consultant to Karuk Tribe, Quartz Valley Indian Reservation, California Sport Fishing Protection Alliance, Cal Trout, Klamath River Keeper, Westerveld Inc, Fishery Foundation of California, and others. Participate in various workgroups and committees of these planning entities. Subjects include ecosystem restoration, Yolo Bypass, fisheries enhancement, aquatic habitat assessment, water rights, water resources development, groundwater and surface water management - review, management, reports, assessments, and analyses.

EXHIBIT 2

SUMMER 2013

The demise of Delta smelt under D-1641 Delta Water Quality Standards

Thomas Cannon
Consultant

Representing
California Sportfishing Protection Alliance

August 2013

Summer 2013

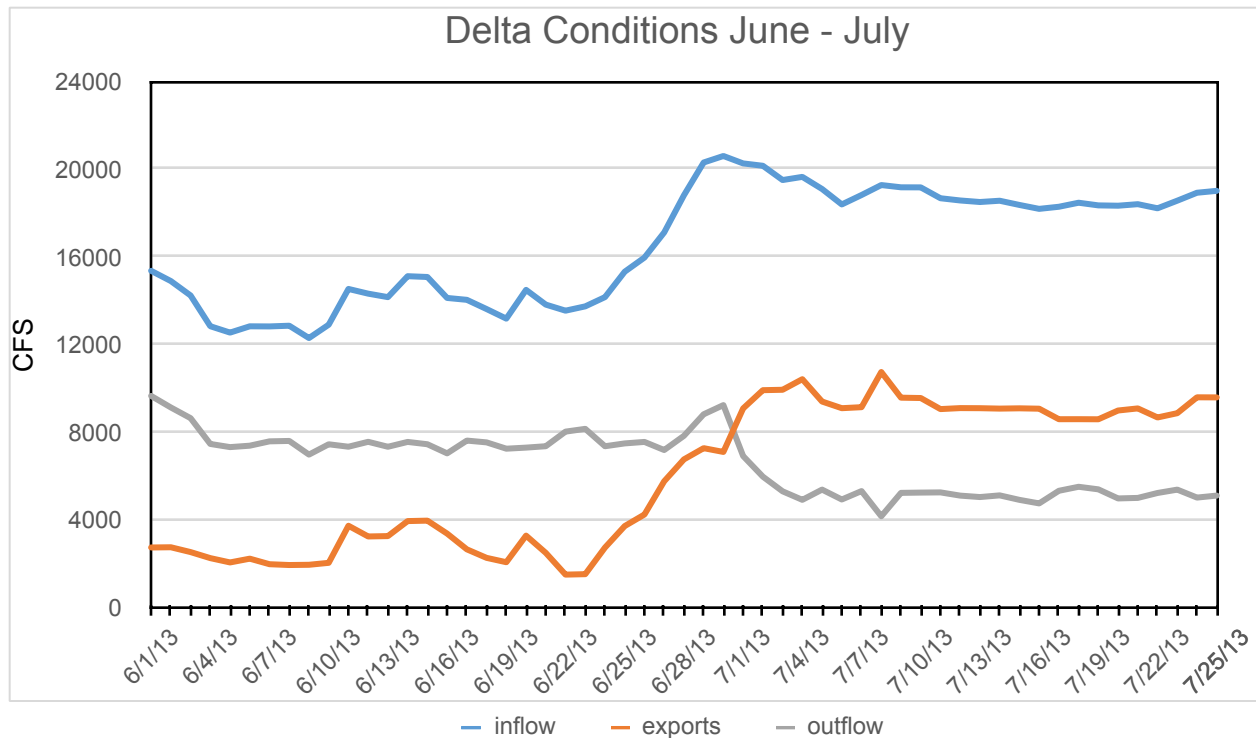

Dry Year Standards Relaxed?

Despite near record low precipitation in the Central Valley in the spring of 2013, the water year remained classified as “dry,” pursuant to D-1641. The “dry year” standards for EC at Emmaton were violated in April, May and June and the EC standard at Jersey Point was violated in June. These standards were established to protect agricultural beneficial uses in the Delta.

The Department of Water Resources and the Bureau of Reclamation, fearing that water exports from the State and Federal Water Projects (Projects) would lead to violations of Delta outflow and western Delta EC standards and depletion of cold water storage in Shasta Reservoir, asked the State Water Resources Control Board on 24 May to reclassify the water year to “critically dry” and requested permission to move the temperature compliance point on the Sacramento River upstream from Red Bluff to Anderson to save the cold-water pool supply in Shasta Reservoir. The Department of Fish and Wildlife, NOAA Fisheries and US Fish and Wildlife Service submitted letters supporting the request.

While the State Board had no authority to arbitrary change a water year classification, it informed the agencies that it “will not object or take any action if the Bureau and Department operate to meet critically dry year salinity objectives for Western and interior Delta.”

On or about June 22, the Projects began substantially increasing exports and Delta inflows, and shortly thereafter significantly reducing Delta outflow per the Delta Standards.

The D-1641 standards for a dry year (Figure 1) already allowed salinity to encroach into the West Delta at Emmaton and Jersey Point. Earlier violations of those standards in the spring had already exacerbated conditions by summer (it should also be noted that South Delta EC standards were also violated in June and July through August 15).

This report reviews conditions in the summer of 2013, the inadequacy of D-1641 dry year standards and the adverse impacts to Delta smelt caused by violation of those already inadequate standards.

TABLE 3 (continued)						
WATER QUALITY OBJECTIVES FOR FISH AND WILDLIFE BENEFICIAL USES						
COMPLIANCE LOCATION	INTERAGENCY STATION NUMBER(RK11)	PARAMETER	DESCRIPTION (UNIT) [2]	WATER YEAR TYPE [3]	TIME PERIOD	VALUE
DELTA OUTFLOW						
		<i>Net Delta Outflow Index (NDOI) [7]</i>	<i>Minimum monthly average [8] NDOI (cfs)</i>	<i>All</i>	<i>Jan</i>	<i>4,500 [9]</i>
				<i>All</i>	<i>Feb-Jun</i>	<i>[10]</i>
				<i>W,AN</i>	<i>Jul</i>	<i>8,000</i>
				<i>BN</i>		<i>6,500</i>
				<i>D</i>		<i>5,000</i>
				<i>C</i>		<i>4,000</i>
				<i>W,AN,BN</i>	<i>Aug</i>	<i>4,000</i>
				<i>D</i>		<i>3,500</i>
				<i>C</i>		<i>3,000</i>
				<i>All</i>	<i>Sep</i>	<i>3,000</i>
				<i>W,AN,BN,D</i>	<i>Oct</i>	<i>4,000</i>
				<i>C</i>		<i>3,000</i>
				<i>W,AN,BN,D</i>	<i>Nov-Dec</i>	<i>4,500</i>
				<i>C</i>		<i>3,500</i>
RIVER FLOWS						
<i>Sacramento River at Rio Vista</i>	<i>D-24 (RSAC101)</i>	<i>Flow rate</i>	<i>Minimum monthly average [11] flow rate (cfs)</i>	<i>All</i>	<i>Sep</i>	<i>3,000</i>
				<i>W,AN,BN,D</i>	<i>Oct</i>	<i>4,000</i>
				<i>C</i>		<i>3,000</i>
				<i>W,AN,BN,D</i>	<i>Nov-Dec</i>	<i>4,500</i>
				<i>C</i>		<i>3,500</i>
<i>San Joaquin River at Airport Way Bridge, Vernalis</i>	<i>C-10 (RSAN112)</i>	<i>Flow rate</i>	<i>Minimum monthly average [12] flow rate (cfs) [13]</i>	<i>W,AN</i>	<i>Feb-Apr 14 and</i>	<i>2,130 or 3,420</i>
				<i>BN,D</i>	<i>May 16-Jun</i>	<i>1,420 or 2,280</i>
				<i>C</i>		<i>710 or 1,140</i>
				<i>W</i>	<i>Apr 15-</i>	<i>7,330 or 8,620</i>
				<i>AN</i>	<i>May 15 [14]</i>	<i>5,730 or 7,020</i>
				<i>BN</i>		<i>4,620 or 5,480</i>
				<i>D</i>		<i>4,020 or 4,880</i>
				<i>C</i>		<i>3,110 or 3,540</i>
				<i>All</i>	<i>Oct</i>	<i>1,000 [15]</i>

Figure 1a. D-1641 EC Water Quality Objectives Table 2.

TABLE 2
WATER QUALITY OBJECTIVES FOR AGRICULTURAL BENEFICIAL USES

COMPLIANCE LOCATION	INTERAGENCY STATION NUMBER (RKI [1])	PARAMETER	DESCRIPTION (UNIT) [2]	WATER YEAR TYPE [3]	TIME PERIOD	VALUE
WESTERN DELTA						
Sacramento River at Emmaton	D-22 (RSAC092)	Electrical Conductivity (EC)	Maximum 14-day running average of mean daily EC (mmhos/cm)		0.45 EC	EC from date shown to Aug 15 [4]
					April 1 to date shown	----
				W	Aug 15	----
				AN	Jul 1	0.63
				BN	Jun 20	1.14
D	Jun 15	1.67				
C	----	2.78				
San Joaquin River at Jersey Point	D-15 (RSAN018)	Electrical Conductivity (EC)	Maximum 14-day running average of mean daily EC (mmhos/cm)		0.45 EC	EC from date shown to Aug 15 [4]
					April 1 to date shown	----
				W	Aug 15	----
				AN	Aug 15	----
				BN	Jun 20	0.74
D	Jun 15	1.35				
C	----	2.20				
INTERIOR DELTA						
South Fork Mokelumne River at Terminus	C-13 (RSMKL08)	Electrical Conductivity (EC)	Maximum 14-day running average of mean daily EC (mmhos/cm)		0.45 EC	EC from date shown to Aug 15 [4]
					April 1 to date shown	----
				W	Aug 15	----
				AN	Aug 15	----
				BN	Aug 15	----
D	Aug 15	----				
C	----	0.54				
San Joaquin River at San Andreas Landing	C-4 (RSAN032)	Electrical Conductivity (EC)	Maximum 14-day running average of mean daily EC (mmhos/cm)		0.45 EC	EC from date shown to Aug 15 [4]
					April 1 to date shown	----
				W	Aug 15	----
				AN	Aug 15	----
				BN	Aug 15	----
D	Jun 25	0.58				
C	----	0.87				

Figure 1b. D-1641 Flow Water Quality Objectives Table 3.

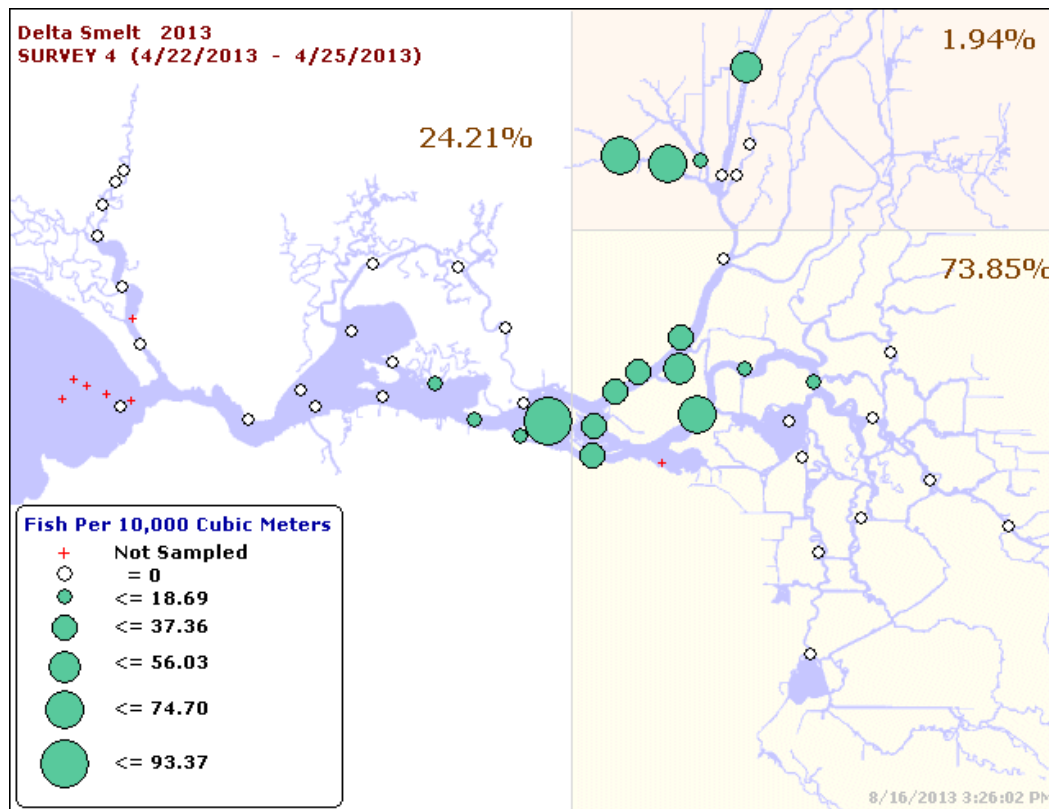

Figure 2. Late-April 2013, 20-mm Smelt Survey results. (Source: <http://www.dfg.ca.gov/delta/data/20mm/>)

Delta Smelt in April

Although not the subject of this report, spring conditions set the stage for summer. April 2013 was a tough time for smelt. Sacramento River inflow to the Delta dropped to only 6,000 cfs, San Joaquin inflows were 1500-3000 cfs, exports were up to 2,500-3,000 cfs, and outflow was as low as 6,000 cfs. Old and Middle River OMR flows were -1000 to -4000 cfs. The Delta Cross Channel was closed.

Over the past 20 years, the late April – early May period had been under the protection of VAMP (Vernalis Adaptive Management Program) experiment, but these protections ended in 2010. This year, without these protections, late April exports climbed to 2,500-3,000 cfs reaching 4,000 cfs in early May (from 1500 cfs cap under VAMP). This increase in exports without the VAMP export cap occurred under lower inflows, outflows, and negative OMR flows. Nearly three quarters of the Delta smelt population was in the Central and Western Delta (20-mm survey, Fig. 2) and thus subject to being exported (especially with negative OMRs with the DCC closed). Most of the smelt were not of salvageable size (they were only 10-25 mm), so they were entrained in the export water likely in large numbers (hundreds of thousands per day were moving into Old River toward pumps).

Despite these horrible conditions many still survived in the western Delta under the modest outflows and thus became subject to summer conditions.

Delta Smelt in Mid June

In mid June 2013 the small remnant population of delta smelt surviving in the San Francisco Bay-Delta after the below-normal water year of 2012 and poor spring conditions described above were spread through their usual dry-year habitats in the western Delta, eastern Suisun Bay, Montezuma Slough, and the Cache Slough/Bypass/Ship Channel complex in the north Delta (Figure 3).

Other than the north Delta group, most of the smelt were in their summer low-salinity zone (LSZ) home where salinities are low (0.5-5 ppt) and water temperature optimal (about 20C). With the protective dry-year EC standard of 0.45 through June 15, the LSZ was in eastern Suisun Bay west of the Delta.

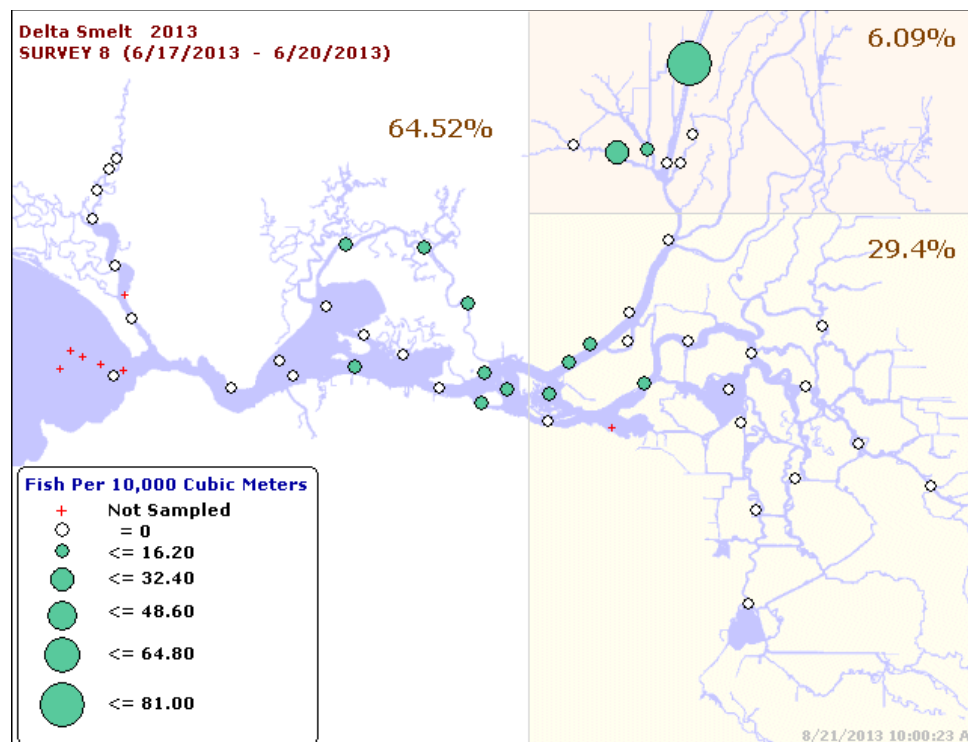

Figure 3. Mid-June 2013, 20-mm Smelt Survey results. (Source: <http://www.dfg.ca.gov/delta/data/20mm/>)

Summer Flow and Salinity Conditions

Beginning in the third week in June, inflow increase from the 12,000-14,000 cfs level to 20,000 cfs and exports increased from 2,000 to 10,000 cfs (Figure 4). A week later Delta outflow was reduced to 5,000 cfs.

West Delta

The effect is seen in the EC patterns at Emmaton and Jersey Point in the west Delta (Figures 5a and 5b). As outflow declines, salinities (EC) increase. The LSZ with its 500-6000 EC signature moved upstream into the West Delta with each incoming tide. In contrast, in wet year 2011, outflow was maintained at 8000 cfs and the LSZ did not move upstream into the Delta (Figure

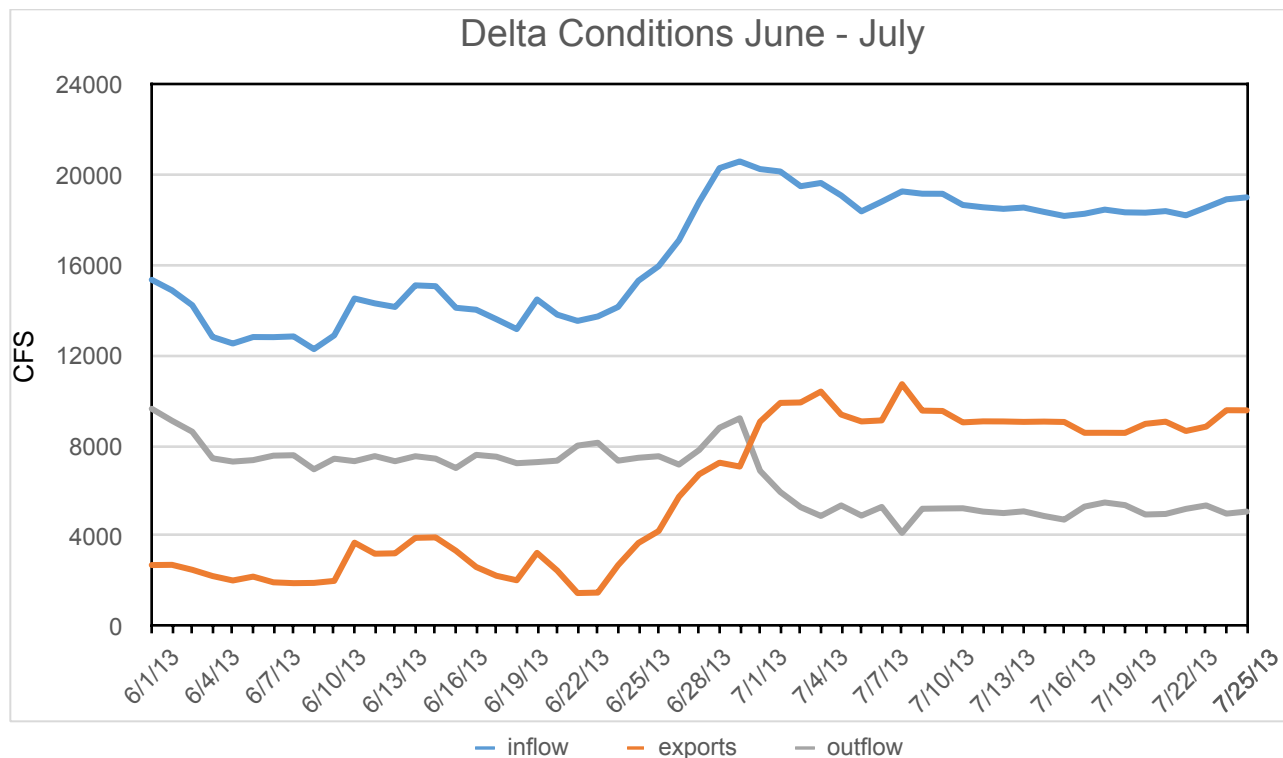

5c).

Figure 4. June through July 2013 Delta inflow, outflow, and exports. Summer EC standards kick in after mid June.

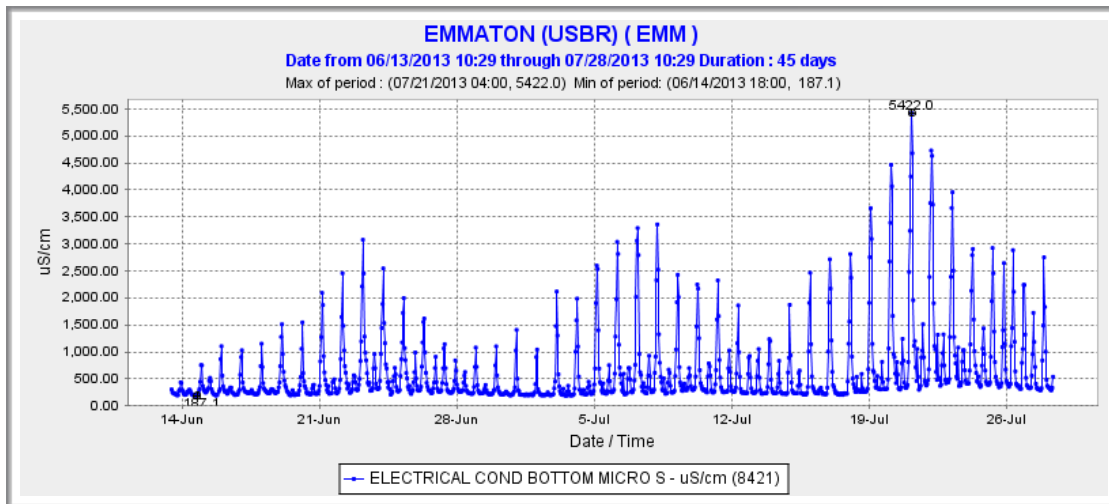

Figure 5a. Conductivity (EC) at Emmaton on lower Sacramento River in West Delta after mid June 2013. (Source: CDEC)

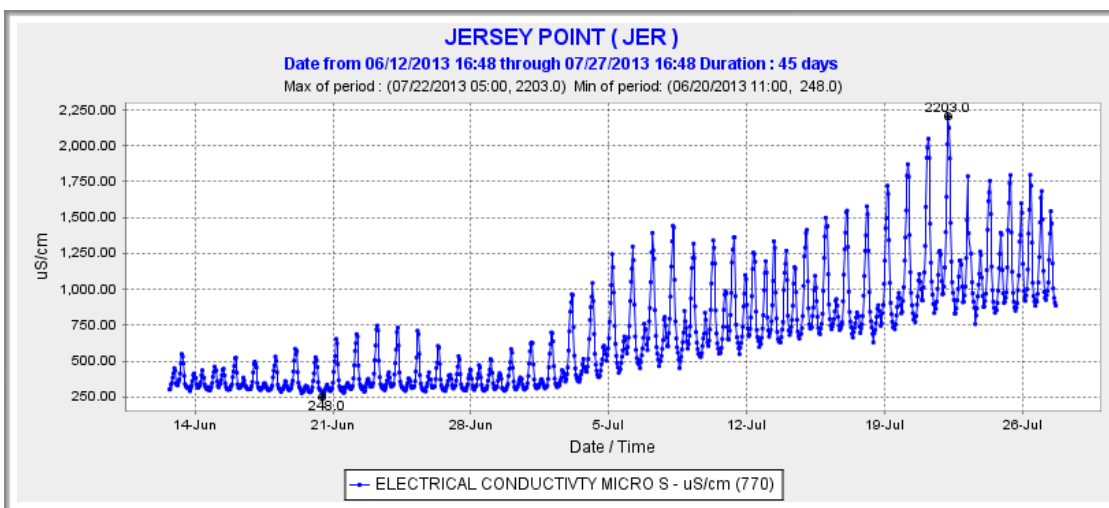

Figure 5b. Conductivity (EC) at Jersey Point on lower San Joaquin River in West Delta after mid June 2013. (Source: CDEC)

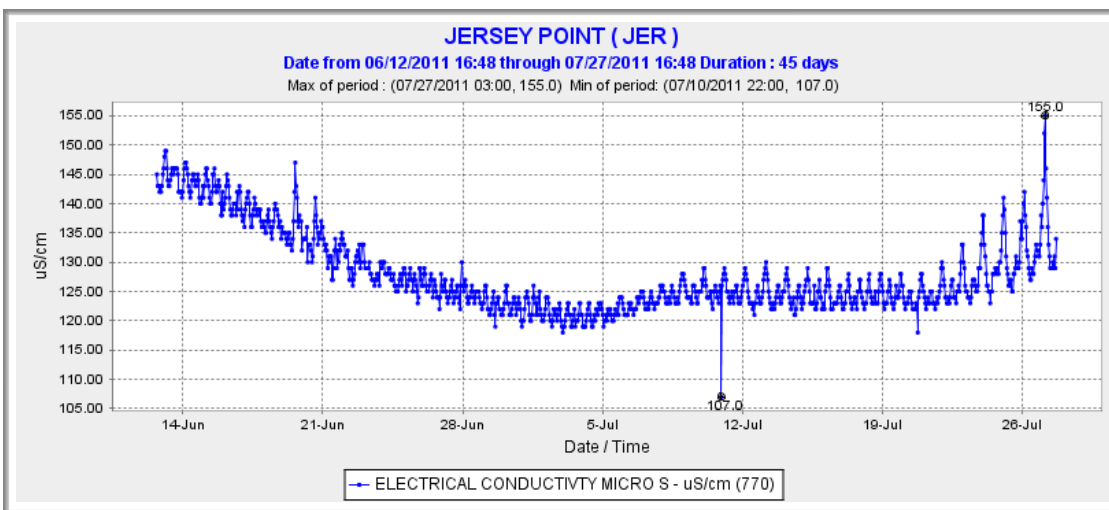

Figure 5c. Conductivity (EC) at Jersey Point on lower San Joaquin River in West Delta after mid June 2011. (Source: CDEC)

Eastern Suisun Bay

Salinity (EC) in Eastern Suisun Bay at Collinsville on the north and Pittsburg on the south also increased at the beginning of July with the decrease in outflow (Figures 6 and 7). At high tide the LSZ was well upstream of the two locations by early July. The lower end of the LSZ did extend downstream to these locations during low tides through July.

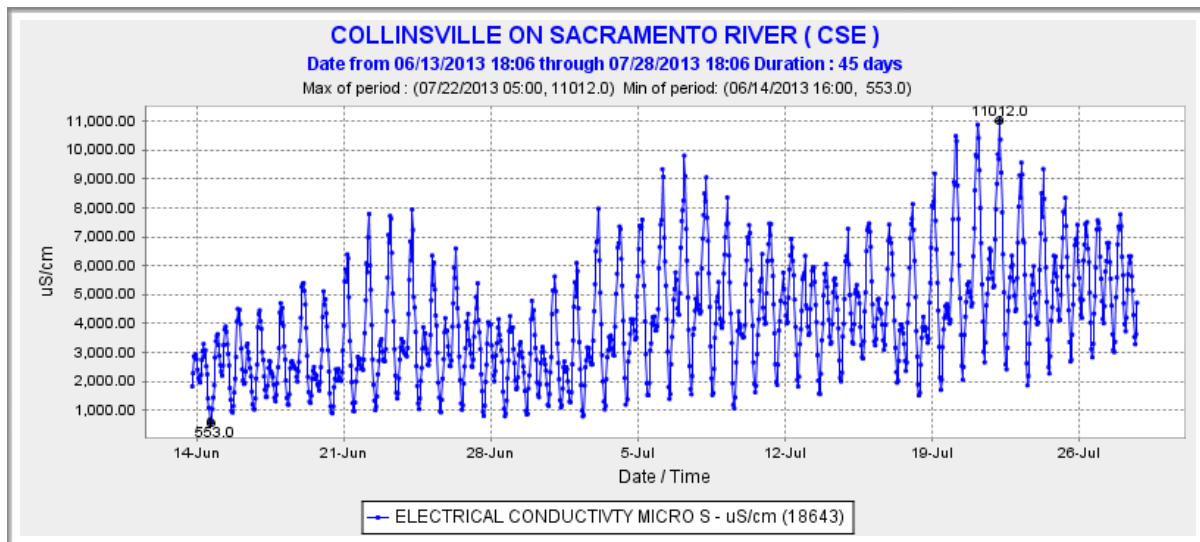

Figure 6. Conductivity (EC) at Collinsville in Eastern Suisun Bay after mid June 2013. (Source: CDEC)

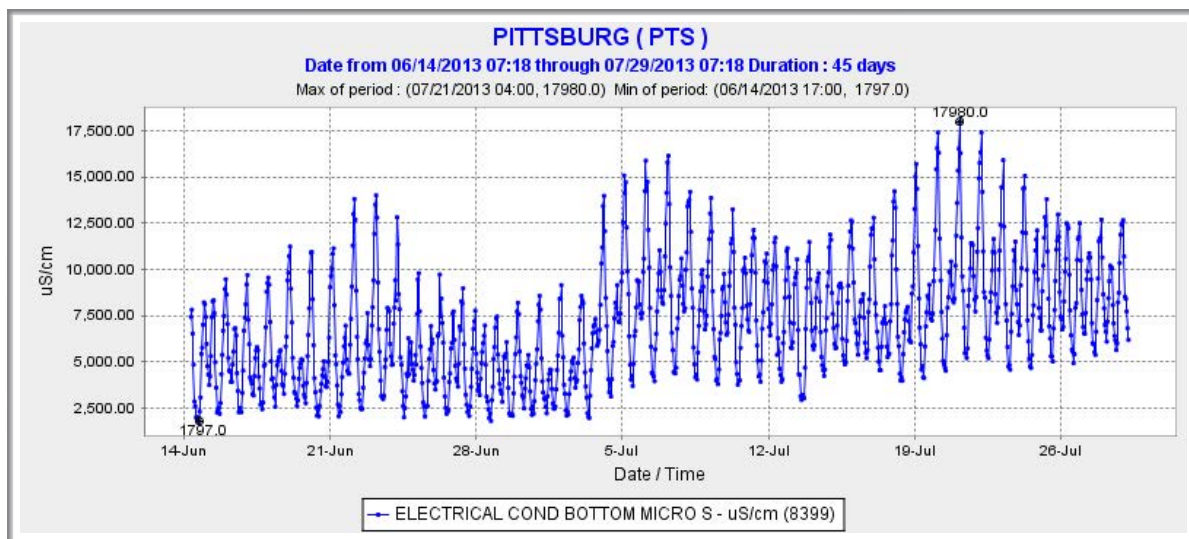

Figure 7. Conductivity (EC) at Pittsburg in Eastern Suisun Bay after mid June 2013. (Source: CDEC)

Central Delta

Central Delta EC as measured Threemile Slough on the San Joaquin River (Figure 8) and False River (Figure 9) also shows the movement of the LSZ upstream coincident with the reduction in Delta outflow at the beginning of July.

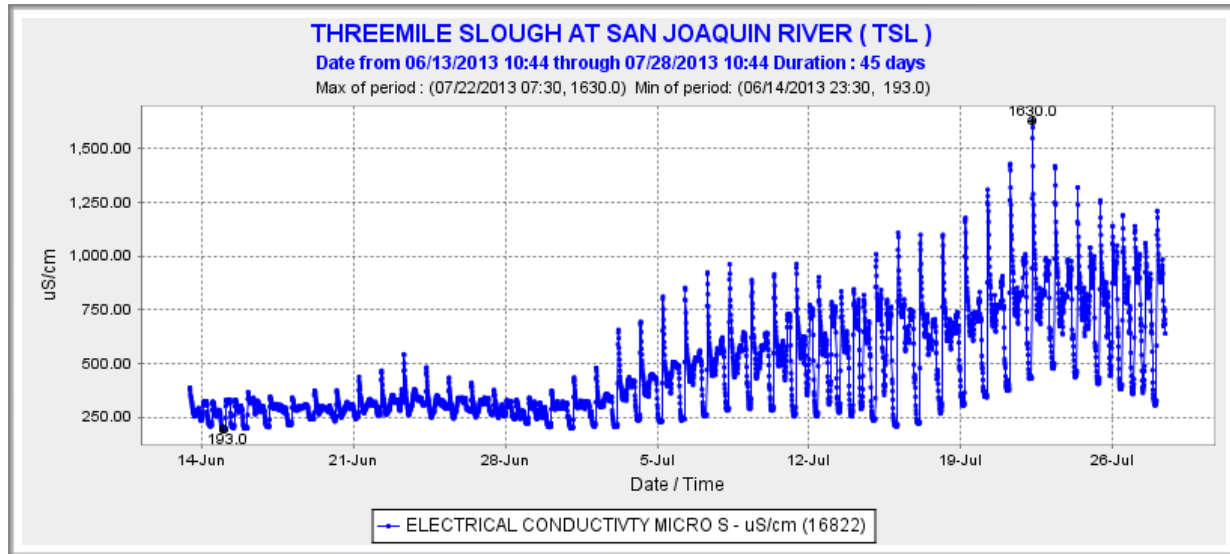

Figure 8. Conductivity (EC) at Threemile Slough in the Central Delta after mid June 2013. (Source: CDEC)

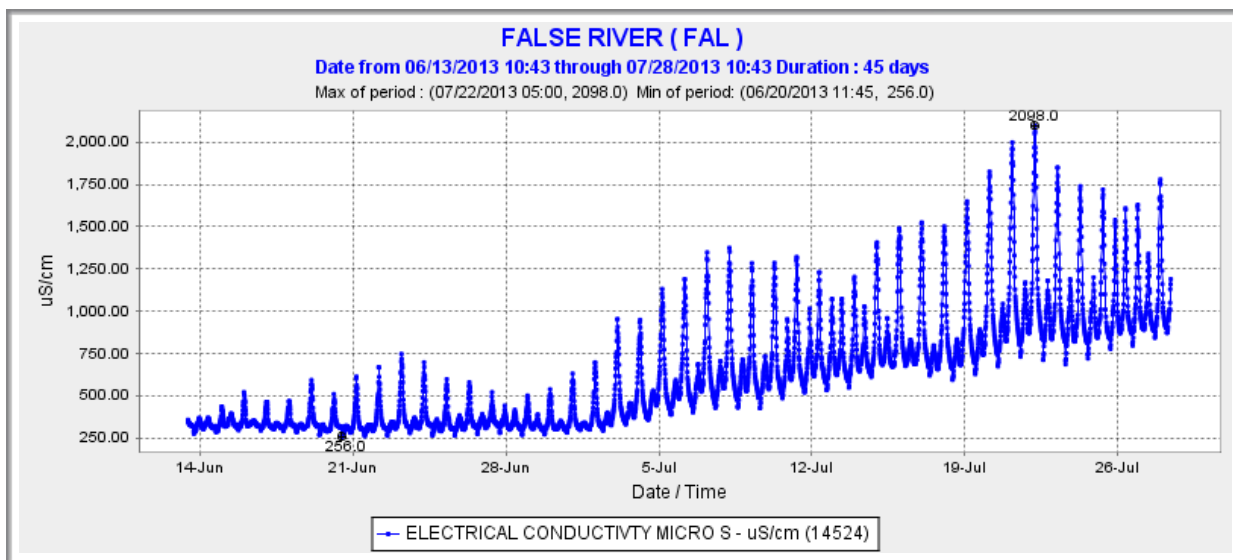

Figure 9. Conductivity (EC) at False River in the Central Delta at Franks Tract after mid June 2013. (Source: CDEC)

South Delta

South Delta EC also increased as the upper portion of the LSZ was mixed with cross Delta moving freshwater Sacramento River on the way to the export pumps. Salinity gradually increased in Old River as the head of the LSZ actually moved into the South Delta toward the export pumps (Figure 10).

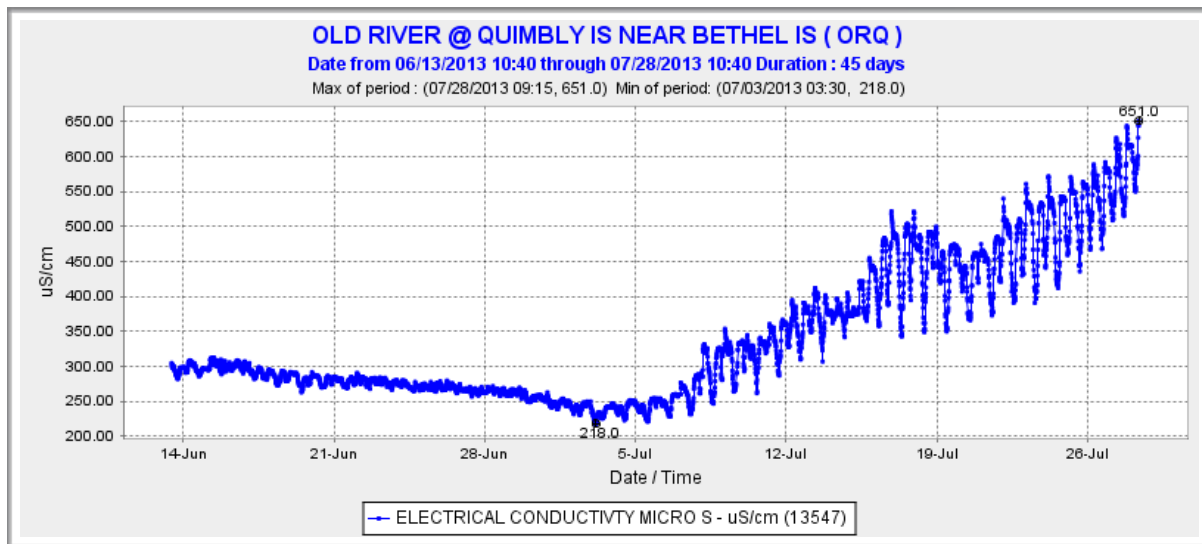

Figure 10. Conductivity (EC) in Old River in the Central Delta near Bethel Is after mid June 2013. (Source: CDEC)

Salinity in Clifton Court Forebay was slightly less as Forebay water is a mixture of Old River, Middle River, and East Delta waters of lower salinity (Figure 11).

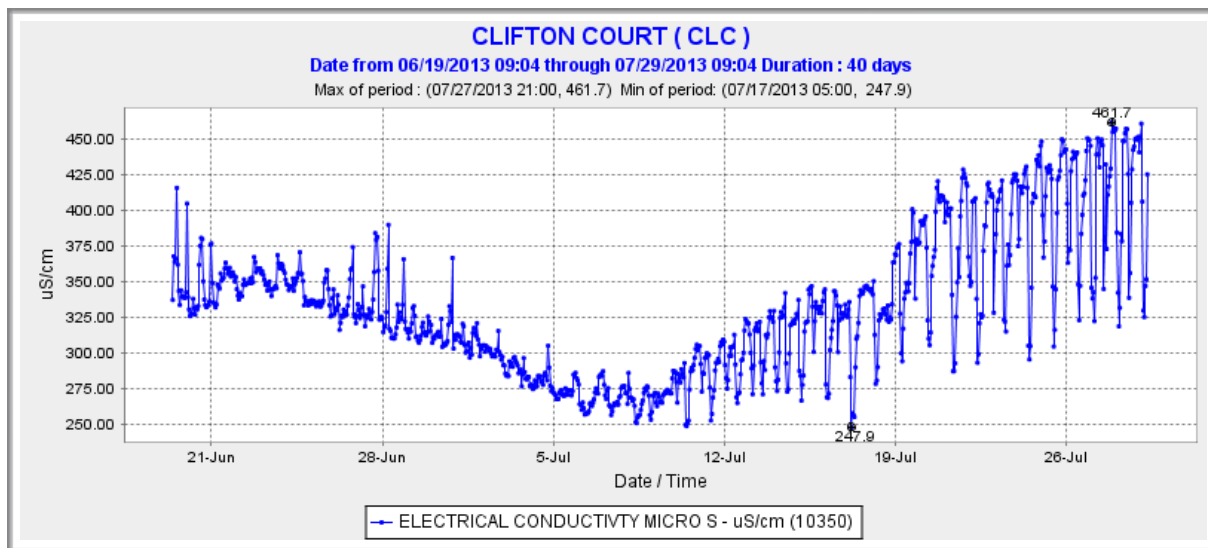

Figure 11. Conductivity (EC) in Clifton Court Forebay after mid June 2013. (Source: CDEC)

Summer Water Temperatures

Western Delta

Water temperatures reached near lethal levels for smelt (75-77F) in the western Delta by the beginning of July (Figures 12-14). Water temperatures rose sharply in late June due to the combination of warm air temperatures and sharply higher Delta inflows. Water temperatures declined thereafter through mid July with lower air temperatures, lower Delta inflows, and cooler waters moving upstream from Suisun Bay with lower outflows.

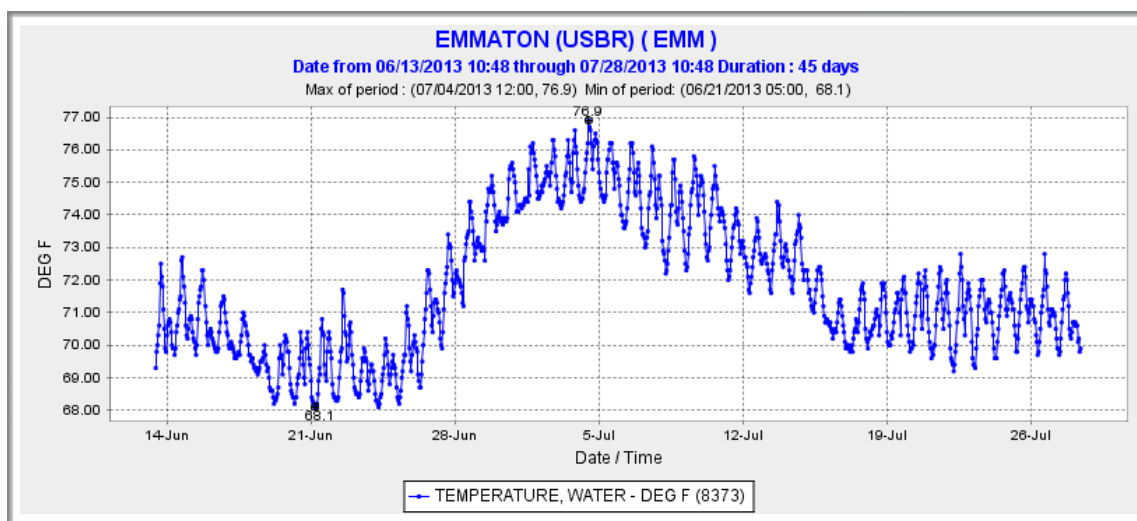

Figure 12. Water temperature at Emmaton mid June through July 2013. (Source: CDEC)

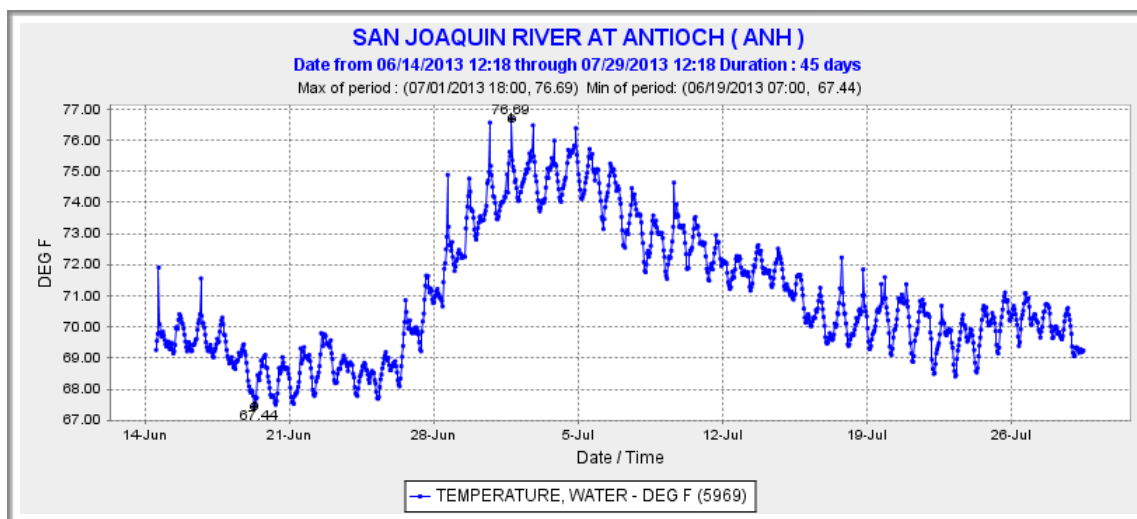

Figure 13. Water temperature at Antioch mid June through July 2013. (Source: CDEC)

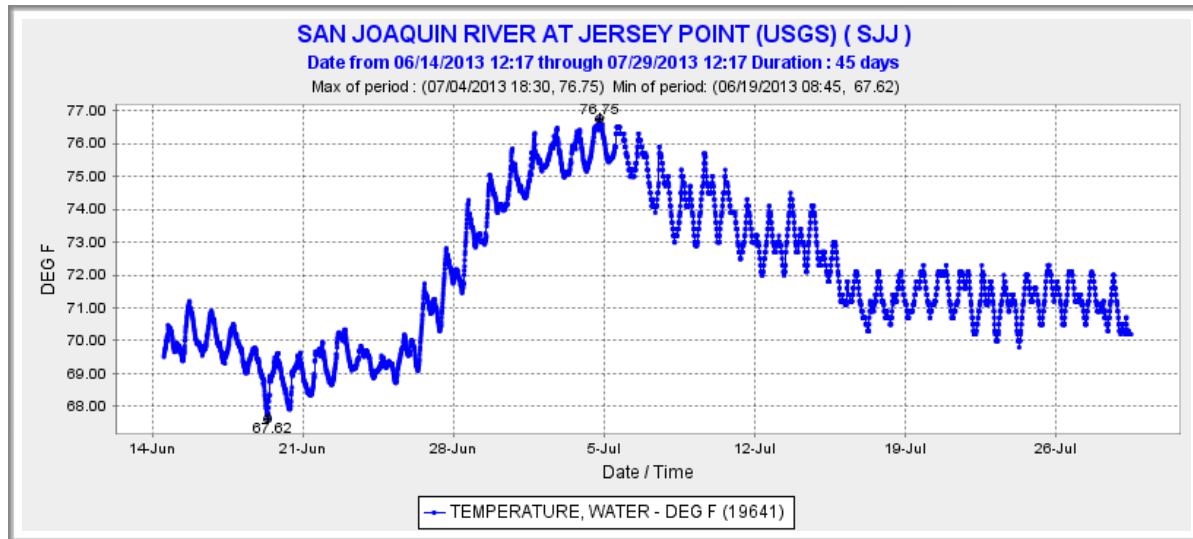

Figure 14. Water temperature at Jersey Point mid June through July 2013. (Source: CDEC)

Central Delta

Water temperatures reached near lethal levels for smelt (75-77F) in the Central Delta by the beginning of July (Figures 15 and 16). Water temperatures rose sharply in late June due to the combination of warm air temperatures and sharply higher Delta inflows. Water temperatures declined thereafter through mid July with lower air temperatures, lower Delta inflows, and cooler waters moving upstream from The West Delta with lower outflows.

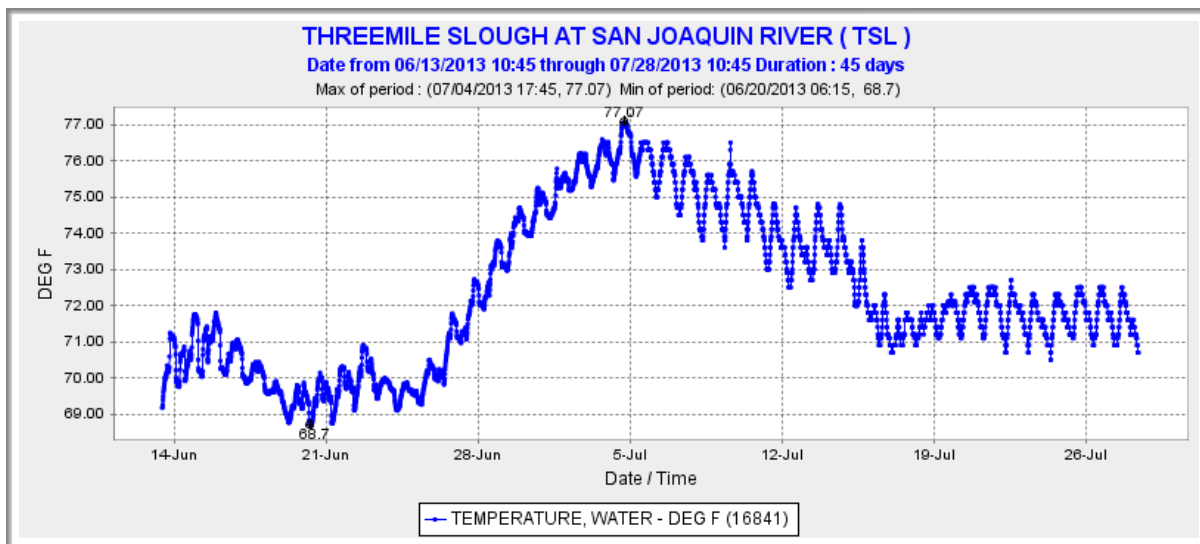

Figure 15. Water temperature at Threemile Slough mid June through July 2013. (Source: CDEC)

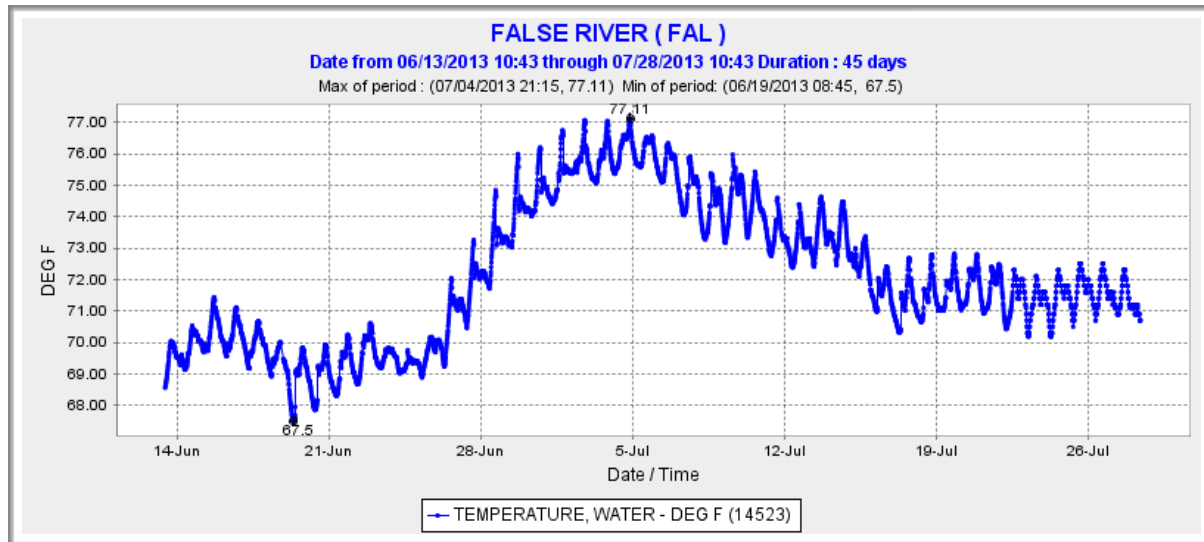

Figure 16. Water temperature at False River mid June through July 2013. (Source: CDEC)

South Delta

Water temperatures reached lethal levels for smelt (78-80F) in the South Delta by the beginning of July (Figures 17-18). Water temperatures rose sharply in late June due to the combination of warm air temperatures, sharply higher Delta inflows, and higher exports drawing warm water into the South Delta. Water temperatures declined thereafter through mid July with lower air temperatures, lower Delta inflows, and cooler waters moving into the South Delta from the western and central Delta with lower outflows.

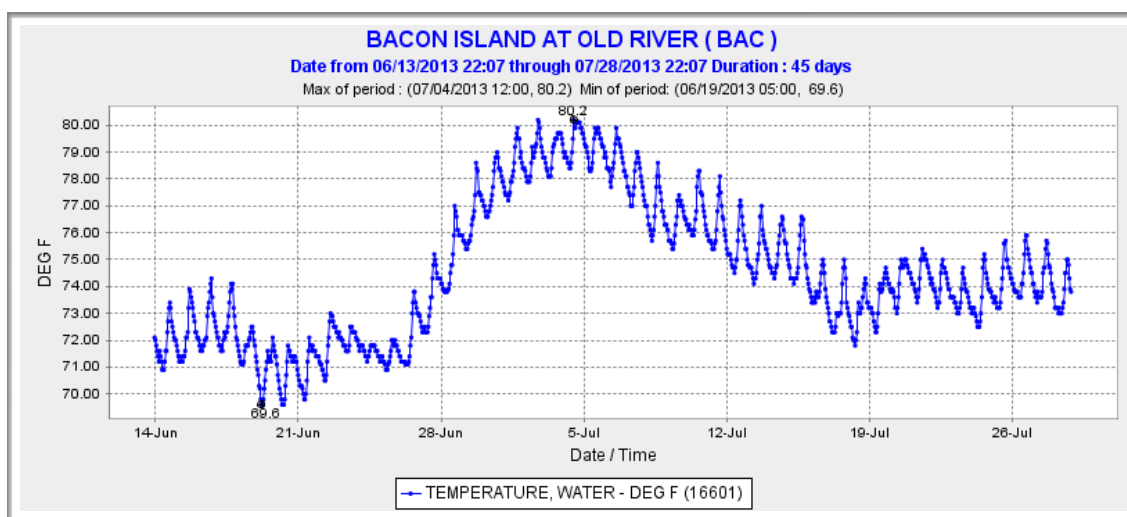

Figure 17. Water temperature in Old River near Bacon Is mid June through July 2013. (Source: CDEC)

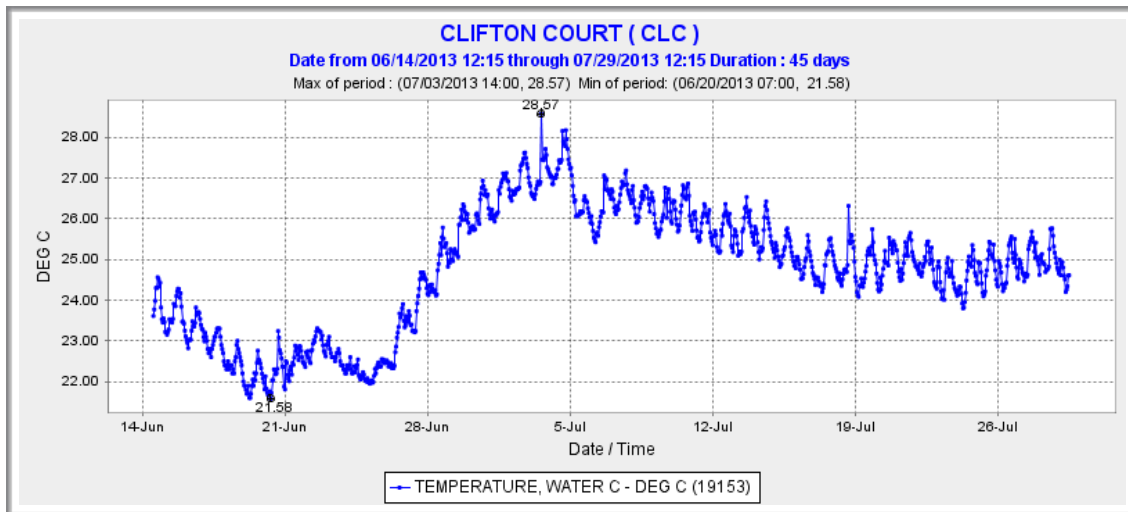
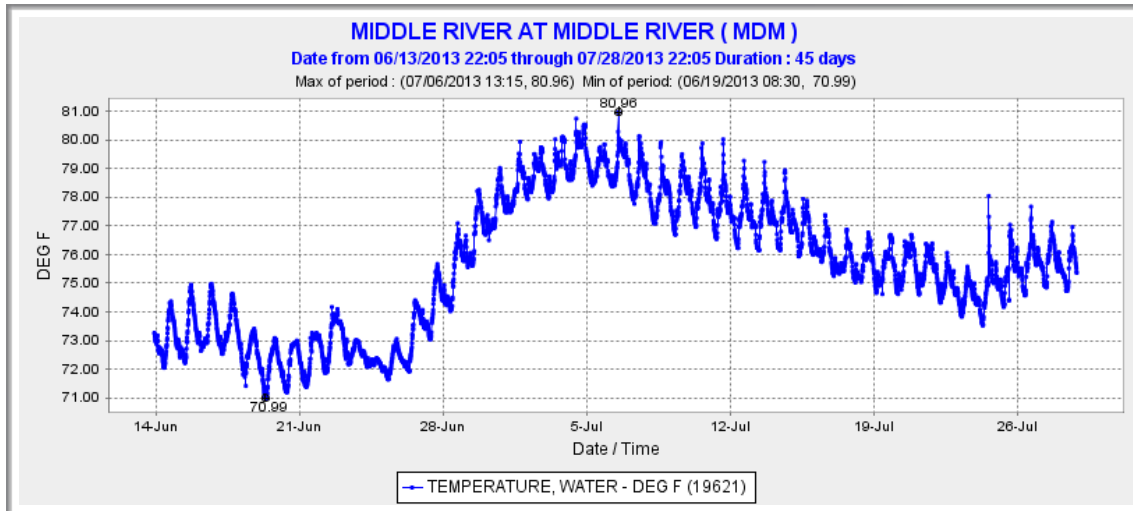

Figure 18. Water temperature in Clifton Court Forebay near Byron mid June through July 2013. (Source: CDEC)

Eastern Delta

Water temperatures in the eastern Delta also reached lethal levels of 80-81F (Figures 19 and 20).

Figure 19. Water temperature in Middle River mid June through July 2013. (Source: CDEC)



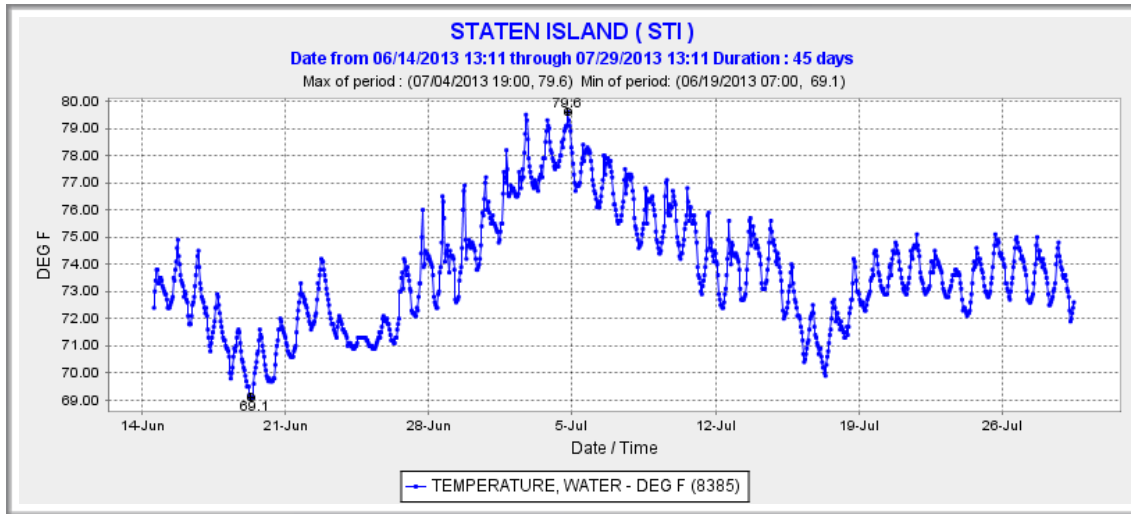

Figure 20. Water temperature near Staten Island mid June through July 2013. (Source: CDEC)

Delta Smelt Vulnerable

With the LSZ reaching into the Central and South Delta at high tides at a greater frequency through July than in wetter years it begs the question as to why were not more smelt salvaged. Clearly small salvage events occurred through mid June coincident with small pulses of exports (Figure 21). But, why not after mid June?

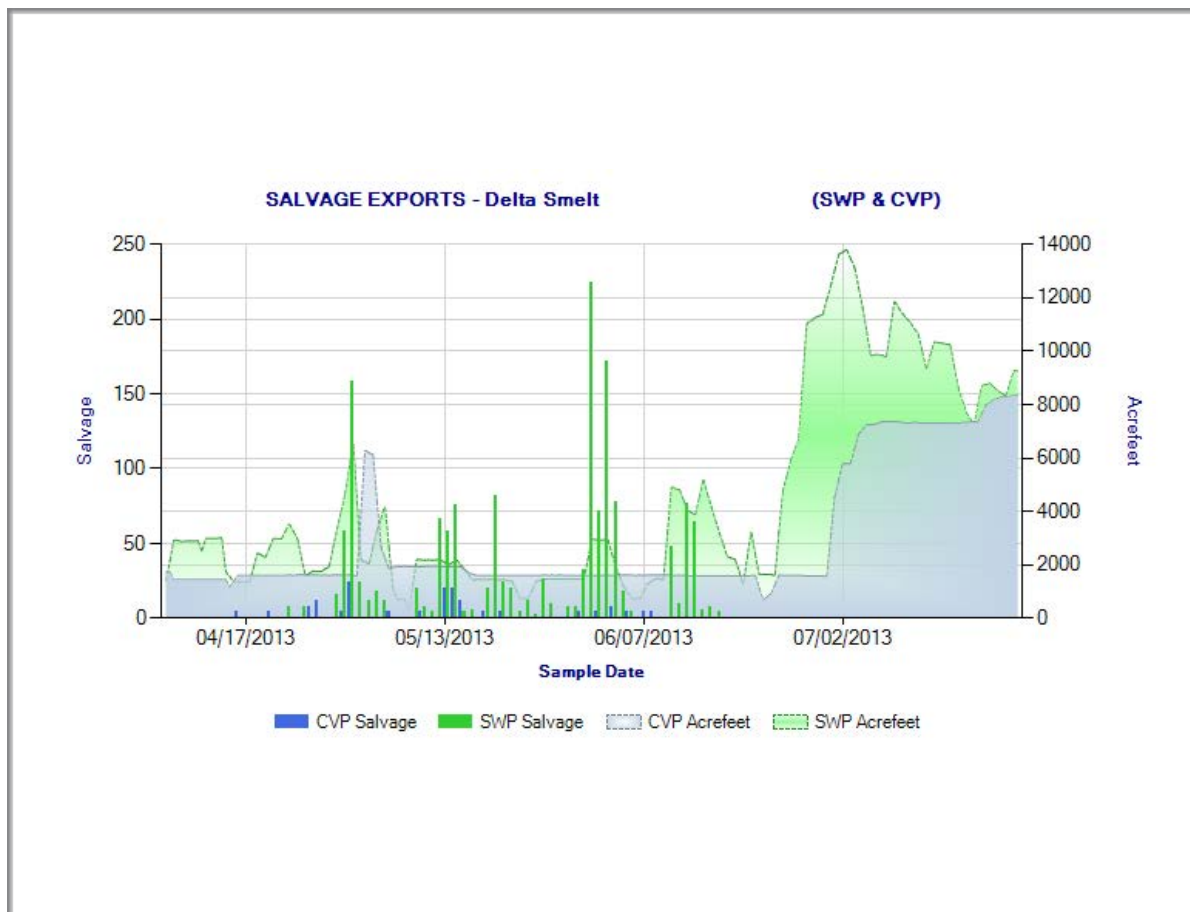

Figure 21. Delta exports and smelt salvage In spring and summer 2013. (Source: USBR MP)

First, the high inflows, low exports and high outflows kept the LSZ away from the influence of the pumps toward the end of June. Until about 8 July export demand was satiated by the pool of freshwater left over in the Delta from prior high inflows as observed in Clifton Court Forebay EC (Figure 11). But soon thereafter evidence of the LSZ being drawn to the pumps was apparent.

So why were no smelt salvaged after exports picked up and the LSZ entered the Central Delta? The answer is high water temperatures by early July. No smelt were able to survive passage to the

South Delta export salvage facilities because of lethal water temperatures in the Central and South Delta.

The high exports and high inflows at the end of June and beginning of July not only pulled the LSZ upstream into the Central Delta and under influence of the South Delta pumps at Clifton Court Forebay, but it also led to a sharp increase in water temperature throughout much of the LSZ that was lethal to delta smelt (77-80F or 25-27C). Warm weather occurred at the beginning of July throughout the Delta (but reaching over 100F to the north and east), along with nearly a week of 20,000 cfs inflow (from the north and east) with high ambient water temperature, and near 10,000 cfs exports resulted in near lethal or lethal water temperatures in the North, Central, West, and South Delta. Smelt were able to survive only in the western portion of the LSZ of eastern Suisun Bay and extreme western Delta (Figure 22) where water temperatures remained sub-lethal at 22-24C.

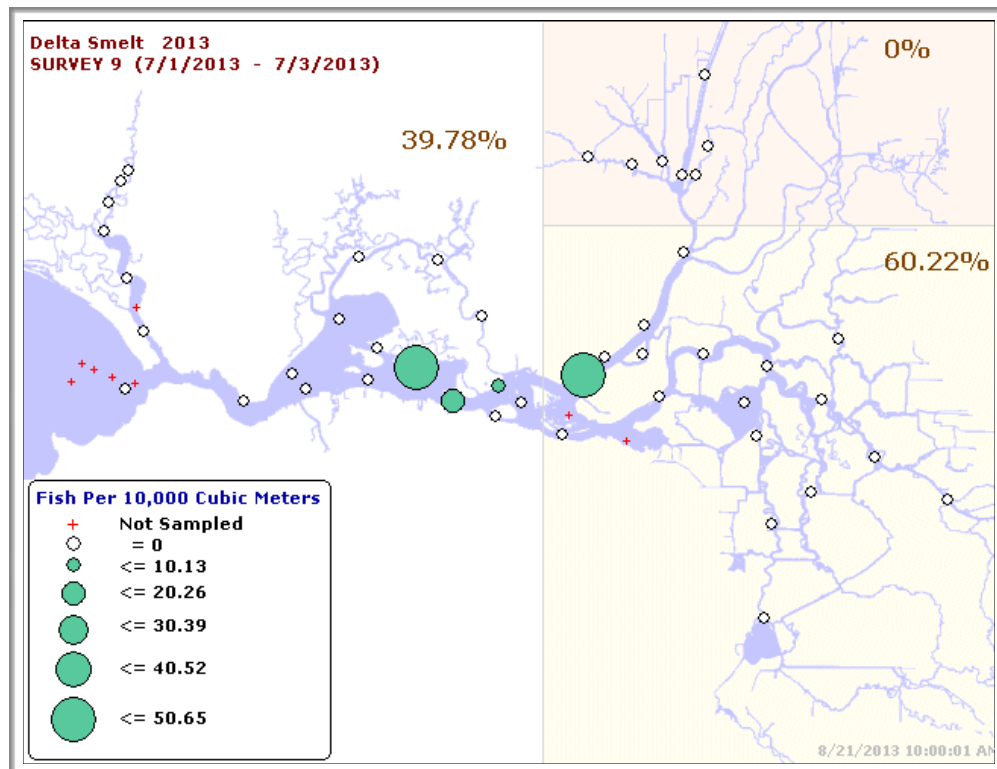

Figure 22. Early July 20-mm Smelt Survey results. (Source: <http://www.dfg.ca.gov/delta/data/20mm/>)

This ninth and last of the Department of Fish and Wildlife's 2013 20-mm Survey shows that the majority of smelt were in the Delta at the beginning of July. The Summer Townet Survey that began in mid June (unpublished CDFW data) has provided a Delta smelt abundance index based upon its first two surveys (weeks of June 10 and 24). The preliminary 2013 index is 0.7, down from last year's 0.9. The results from the remaining Summer Townet Survey and the Fall Mid-

Water Trawl Survey will help reveal the full extent to which Delta smelt were harmed by Project operations this summer. Based upon my decades of experience, I suspect that summer 2013 parallels the conditions during the Pelagic Organism Decline (POD) and record low smelt indices early in the last decade.

Solution

The problem remains that neither the D-1641 Water Quality Objectives for the Delta or the OCAP Biological Opinions have protections for Delta smelt after June. The demise of VAMP's limit on exports in the late spring has exacerbated the problem. The D-1641 dry and critical year standards for outflow are simply too low to protect delta smelt and their important habitats. Even with higher outflows, excessive exports remain a problem. The inflows necessary to sustain high exports reduce reservoir storage and cold-water pools, and bring warmer, low-productive reservoir water into the Delta and LSZ. Cooler, more productive, more turbid water, critical to delta smelt growth and survival is first exported from the Delta and then replaced with warm, low turbidity, low productivity reservoir water. Higher summer outflow and reduced exports (and a minimum of inflow necessary to sustain reduced exports) in drier years are fundamentally necessary for delta smelt recovery. A minimum of inflow and exports will increase residence time and productivity, allow higher productivity waters and smelt to remain in the Delta, and allow Delta waters to remain cooler to sustain smelt.

EXHIBIT 3

Review of Summer 2014 Water Transfers Federal Environmental Assessment

Introduction

On April 25, 2014, Governor Brown issued a Proclamation of a Continued State of Emergency related to the drought. The Proclamation finds that California's water supplies continue to be severely depleted despite a limited amount of rain and snowfall since January, with very limited snowpack in the Sierra Nevada mountains, decreased water levels in California's reservoirs, and reduced flows in the state's rivers. The Proclamation orders that the provisions of the January 17, 2014 Proclamation remain in full force and also adds several new provisions including: the State Water Board and the Department of Water Resources (DWR) are to expedite requests to move water to areas of need.

Federal water contractors in the Sacramento Valley recently were allocated by the US Bureau of Reclamation (Reclamation) up to 75% of their contract amounts of Central Valley Project (CVP) water this summer, while more "junior" water contractors in the San Joaquin Valley received 0%. The San Joaquin contractors would like to purchase some of the allocated water from the north and transfer it for their use through the federal Central Valley Project export facilities in the Delta to the south. Reclamation, which co-operates the Delta export facilities with the State Water Project, must notice the transfer under the National Environmental Policy Act (NEPA) as a federal action for public review and comment. Reclamation has provided public notice of the proposed transfers under a Finding of No Significant Impact (FONSI) with a supporting Environmental Assessment (EA).

This document summarizes the major findings of my review of Reclamation's findings specifically as they apply to the effects of the proposed water transfers on Longfin and Delta smelt, two endangered species that reside in the Bay-Delta estuary and who may be adversely affected by the proposed water transfers. The Delta Smelt are only found in the Delta and are at their lowest population level ever recorded. Both smelt populations decline significantly in droughts. Water transfers are a contributing stressor in droughts.

The proposed water transfers would be carried out under applicable Delta protections for water quality and fish (and other beneficial users). The main protections are from the Delta Water Quality Control Plan (D-1641 Water Quality Standards), two federal Endangered Species Act biological opinions (one from the National Marine Fisheries Service for salmon, steelhead, and sturgeon; the other from the US Fish and Wildlife Service for Delta Smelt), and a State Endangered Species Act Incidental Take Permit (ITP) for state listed salmon, steelhead, and smelt (Longfin and Delta smelt). The State Water Board modifies the Standards regularly with Orders upon receiving requests from the California Department of Water Resources and concurrence from others. Water transfers are generally exempt under these Orders.

53

54

The Delta water quality standards have been modified under recent State Water Board orders to save water supplies in reservoirs that have been depleted during the three years of drought. Delta outflow and salinity standards (required minimal limits) have been relaxed for the summer under recent orders to reduce the release of reservoir water to the Delta normally prescribed to block salt water intrusion from San Francisco Bay. The state and federal resource agencies responsible for protecting the listed endangered species in the Delta have generally concurred with provisions of the orders.

54

Water transfers come in various forms and may conform to the existing water quality standards and biological opinions, or have their own special rules from specific Orders or changes to biological opinions after consultations with agencies. The federal Central Valley Project (Shasta, Folsom, and New Melones reservoirs) and State Water Project (Oroville Reservoir) are the major sources of water transfer water. However, generally water transfers involve the sale of water from one entity to another. A good example is the sale of Yuba County Water Agency water from Bullards Bar Reservoir on the North Fork of the Yuba River to state and federal water contractors. The purchased water (often 50,000 acre-feet per year) is released over the summer down the Yuba River into the Delta for export "on top of" normal state and federal Delta exports under a special set of rules. While normal summer exports are limited to 65% of the freshwater inflow to the Delta, water transfer water released from reservoirs to the Delta may be exported at 100% of the added contribution to Delta inflow. Therein lies the basic problem with water transfers through the Delta.

55

In the Yuba summer transfer example there is a whole array of actions and potential problems or ramifications. First, water is released from the reservoir for an unintended purpose (not Yuba County irrigation). Storage is lowered. Recreation and future supplies are affected. The Yuba River (and Feather River) is subjected to abnormal flow patterns (good and bad). Extra electricity is generated above that normally allowed under the Yuba Accord. Second, the water enters at the north end of the Delta's tidal bowl and is exported on paper at the south end via the South Delta export pumps. What gets exported is really not Yuba water, but a mix of tidewater habitat with endangered species and their foodweb organisms.

Another good example of a water transfer through the Delta is the spring 30-day flow pulse from San Joaquin Valley reservoirs (100-150 thousand acre-feet) under the guise of a "fish flow". Normal rules call for export of only 35% of spring Delta inflow, but this transfer is allowed to export 100% or 1:1. This transfer occurs from mid-April to mid-May with several thousand cfs of water entering the South Delta from the San Joaquin River at Vernalis. The sources of the pulse flow are the Sierra reservoirs on the Stanislaus, Merced, and Tuolumne Rivers.

56

The problem with transfers is that each is usually small and flies under the radar, but together can have a large cumulative effect that generally is not considered and often ignored. Therefore assessments of transfer effects need consider the individual (local) effects, but more importantly the cumulative effects of the entire array of transfers.

The water transfers proposed by Reclamation are just a subset of the overall transfers proposed this summer. Reclamation's Environmental Assessment covers only proposed federal contractor transfers, and thus does not present sufficient information to assess the true nature and full extent of impacts of all the potential transfers that may occur this summer. Therefore this review is limited only to the specific effects of the proposed federal transfers, with some insights as to the overall effect of all the transfers.

57

The following review lays out the basis for my assessment in a way that is hopefully understandable to those not as familiar as me with the complexities of the Delta. The workings of the state and federal water project, the role of water quality standards, and their effects on Delta fish biology are generally highly contentious.

I provide a summary of my qualifications up front in the report to show my experience with the subject. I am very familiar with the workings and problems of the state's Delta water quality standards and the biological opinions for endangered Central Valley and Delta fishes. I understand how the water quality standards work and how the recent State Water Board orders affect Delta operations and fish. I attempt to explain how the Delta water quality standards work and how Delta operations and the resulting hydrology affect the Longfin and Delta smelt populations. I address how moving transfer water through the Delta for export under relaxed water quality standards places great risk to the smelt and the habitats they and many other species depend upon. I explain the key issues as I see and understand them, and include the data and analyses that support my reasoning. I have tried to minimize the vast amount of technical jargon that plague Delta issues.

I start with background on my qualifications and experience, and then summarize the water transfer requests, how they would work, and my assessment and conclusions. My focus on five key questions:

1. **Will water transfers increase the exposure of Longfin or Delta smelt to South Delta Exports?**
2. **Will water transfers reduce the growth or survival potential of smelt populations?**
3. **Will water transfers increase the risk of extinction of the smelt species?**
4. **Would water transfers under D-1641 standards pose a greater risk to smelt than would otherwise occur without water transfers?**
5. **Would water transfers under D-1641 standards for the transfer period as relaxed per the May 2, State Board Order pose a significant risk to smelt as compared to transfers under normal D-1641 standards for the transfer period?**

Experience and Qualifications

I am a specialist in assessing environmental effects on fish and their aquatic habitats. I have over 40 years of experience at this along with degrees in fisheries, biology, and biostatistics. My professional career has focused on estuarine fisheries ecology with experience on East Coast and West Coast estuaries including 25 years since 1977 relating to the Sacramento-San Joaquin Delta Estuary. From 1977-1980 I was project director of Bay-Delta ecological studies for PG&E's Bay-Delta power plants effects studies. From 1980-82, I was a consultant to the State Water Contractors, the National Marine Fisheries Service, and State Water Resources Control Board (State Board) determining the effectiveness of the 1978 Bay-Delta Water Quality Standards in protecting the Bay-Delta ecosystem and striped bass population. From 1986-1987 I was a consultant to the State Water Contractors and Bureau of Reclamation during the State Board hearings on water quality standards. From 1994-1995, I was a consultant to the State Water Contractors and the California Urban Water Agencies, working on the 1995 Bay-Delta Water Quality Standards and how the new standards would affect the Bay-Delta ecosystem and its fish populations. From 1995-2003 I was a consultant to the CALFED Bay-Delta Program where I worked on various teams assessing the effects of alternative Delta operations and water supply infrastructure. From 2002 to 2010 I was involved in activities related to the Striped Bass Stamp Program, Salmon Hatchery Program, and Delta fish surveys funded by the US Fish and Wildlife Service to assess the effects on Delta fish and habitats. In the past decade I have

worked closely with the Fishery Foundation of California, the California Striped Bass Association, and the California Sport Fishing Protection Alliance on Delta science related issues including water quality standards and the Bay Delta Conservation Plan (BDCP). Most recently I have reviewed the effects of the various drought-related orders of the State Water Board and the potential effects of the State's 2014 Drought Plan on the Bay-Delta Estuary's fish populations and habitats.

Water Transfer Proposal

Reclamation proposes to transfer up to 175,000 acre-feet of Central Valley Project water allocated to Sacramento Valley federal water contractors to San Joaquin Valley federal water contractors. The water would be released from Shasta Reservoir (at a rate of 205-420 cfs depending on the willingness of sellers) this summer and routed down the Sacramento River into the Delta where it will be exported at the federal South Delta export facilities to the San Joaquin Valley via the federal Delta Mendota Canal. The proposal states that the transfer through the Delta would occur under existing water quality standards and biological opinions requirements, as amended through agency consultations (Figure 1).

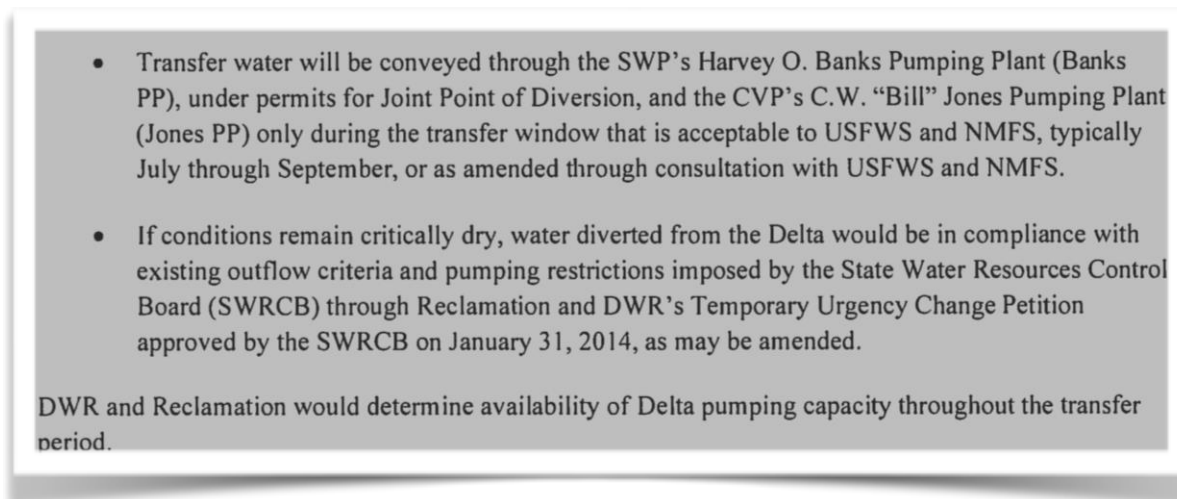

Figure 1. Transfer water conveyance (from Reclamation's FONSI letter)

Restrictions on Water Transfers

Under State Water Board orders, export restrictions in the Delta water quality standards would not apply to water transfers. Salinity standards would apply; however, these standards have been relaxed to accommodate water transfers. A small portion of the transfer water amount entering the Delta may not be exported in order to maintain specific salinity standards. Biological opinion export restrictions only apply through June. Thus to avoid these restrictions, the proposal only applies for the summer (July-September). In summer, exports are restricted to 65% of freshwater inflow, but this limitation does not apply to water transfers between state or federal water contractors. The State Water Board orders restrict exports from the Delta to health and safety needs of no more than 1,500 cfs, with the exception of transfers. *"Any exports greater than 1,500 cfs shall be limited to natural or abandoned flows, or transfers. Additionally, DWR and Reclamation, in cooperation with the fishery agencies, will*

consider transfer requests on an individual basis. The Interagency 2014 Drought Transfers Group will help facilitate the approval of proposed transfers." (Source: <http://ca.gov/drought/pdf/2014-Operations-Plan.pdf>; page 10.)

58

Summary of Reclamation Assessment

Reclamation has issued a Finding of No Significant Impact (FONSI) based on the following reasoning:

In their FONSI cover letter, the Bureau stated that their Environmental Assessment-Incidental Take Statement (EA/IS) analyses indicated after a "*thorough and systematic evaluation*" that "*no potentially significant environmental impact may occur as a result of the Proposed Action, as mitigated.*" Their specific statement on effects on fish resources follows in Figure 2. Their assessment as to potential cumulative effects of these and other transfers follows in Figure 3.

FISHERY RESOURCES

Water transfers would slightly increase river flows downstream of the point of diversion relative to the No Action Alternative during the transfer period. Reclamation is consulting frequently with USFWS and NMFS on CVP and SWP operations relative to the BOs and special status fish species in the Delta. Special status fish species would not be affected by the Proposed Action beyond those impacts considered by the BOs and current consultations with NMFS and USFWS.

The Proposed Action would result in increased conveyance through the Delta during the transfer period (July through September, unless it shifts based on feedback from NMFS and USFWS). Special status fish species are generally not in the Delta during the transfer period (July-September) and effects to these fish species from transferring water during this timeframe were considered in the NMFS and USFWS BOs. Transfers would slightly increase inflow into the Delta, but would not change outflow conditions as compared to the No Action Alternative. The incremental effects of transfers on special status fish species in the Delta from water transfers would be less than significant.

Figure 2. Reclamation's effects statements from FONSI letter.

11. Cumulative Impacts: The cumulative impacts analysis considers other potential water transfers that could occur in the 2014 transfer season, including non-CVP water transfers and other existing water transfer and groundwater programs, including the Lower Yuba River Accord. Given the short-term nature of the Proposed Action, Environmental Commitments and minimization measures, impacts to the previously discussed resource categories associated with the Proposed Action will not contribute to a cumulatively significant adverse impact when added to other past, present, and reasonably foreseeable future actions. The Proposed Action would not adversely affect the human environment and therefore would not contribute to any long-term effects on environmental resources. The Proposed Action will not result in cumulative impacts to any of the resources previously described.

Figure 3. Reclamation's cumulative effects statement from FONSI letter

My Review Approach

My assessment is focused on the potential effects of the proposed water transfer on Longfin and Delta populations residing in the Delta during the summer of 2014. Specifically, I have assessed how the added Sacramento River Delta inflow and export of 205-420 cfs from the South Delta this summer would potentially affect the smelt populations. I also address the veracity of the Bureau's impact arguments and conclusions.

Information Used for My Review

In preparing for this review and assessment of the effects of proposed water transfers on the listed smelt and their habitats, I have reviewed the daily patterns of Delta operations in recent drought years including 2014 through mid-May. In addition to the reviewing the water transfer proposals and the associated Reclamation environmental assessment and State Board orders, I have reviewed and used hourly or daily data on hydrology, water quality, Delta pumping plant operations and fish salvage, and smelt distributions in the Delta available via the Internet at various state and federal agency web sites. Most helpful is the review and analyses of the agencies' Smelt Working Group (SWG) that has met and reported weekly on Delta operations and the effect of drought operations on as well as assessments of risk to the smelt populations. The Smelt Working Group weekly reports¹ include data from special real-time smelt surveys not available from other sources, as well as the opinions of its members on relevant subjects.

Review and Analyses

The basis for my review and analyses of effects of the proposed water transfers is a comparison of without-transfer conditions expected this summer with expected with-transfer conditions. Both conditions include recently relaxed water quality standards. The conditions this summer will be somewhat unique because for the first time in nearly 20 years the applicable Delta water

¹ http://www.fws.gov/sfbaydelta/cvp-swp/smelt_working_group.cfm

quality standards have been relaxed because of the present extreme drought². Specifically, (1) the critical year summer standard of 4000 cfs Delta outflow has been reduced to 3000 cfs; (2) the Delta salinity standard³ for the Emmaton site has been moved upstream approximately 2.5 miles to Three Mile Slough; and (3) South Delta exports are limited to 1500 cfs from the normal maximum of 11,400 cfs or 65% of Delta freshwater inflow (whichever is less), not including transfers.

Summer Delta Conditions per D-1641 Standards: Without Transfers:

- Delta Inflow – comprised of abandoned flow and reservoir releases necessary to meet revised standards for Delta outflow and salinity.
- South Delta Exports \leq 1500 cfs
- Delta Outflow \geq 4000 cfs
- Delta Salinity at Emmaton = (\leq 2.78 mmhoes EC or \sim 1.7 ppt salinity)

Summer Delta Conditions per D-1641 Standards: With Transfers:

- Delta Inflow – comprised of abandoned flow and reservoir releases necessary to meet revised standards for Delta outflow and salinity as well as added water transfer inflow (205-420 cfs)
- South Delta Exports \leq 1500 cfs plus additional 205-420 cfs transfer water
- Delta Outflow \geq 4000 cfs
- Delta Salinity at Emmaton = (\leq 2.78 mmhoes EC or \sim 1.7 ppt salinity)

Summer Delta Conditions per D-1641 Standards: As Relaxed by May 2 Order: With Transfers:

- Delta Inflow - abandoned flow and reservoir releases necessary to meet standards for Delta outflow and salinity, as well as added water transfer inflow (205-420 cfs)
- South Delta Exports \leq 1500 cfs plus 205-420 cfs transfer water
- Delta Outflow \geq 3000 cfs
- Delta Salinity at **Three Mile Slough** = (\leq 2.78 mmhos EC or \sim 1.7 ppt salinity⁴)

Smelt Risk Assessment: Summer Delta Conditions per D-1641 Standards: Without Transfers

² http://www.swrcb.ca.gov/waterrights/water_issues/programs/drought/docs/tucp/050214_tucp_order.pdf

³ Note: the “Table 2 Western Delta Sacramento River” salinity requirement is 2.78 EC, which is about 1.7 ppt (or psu). Thus, the compliance location for the “Table 2 Western Delta Sacramento River” salinity requirement in Three Mile Slough is a good indicator of the center of the low-salinity zone that defines young Delta Smelt habitat in the Delta in the transfer period.

⁴ This is very close to the expected average location of X2 (2 ppt), which would vary from EC as a function of water temperature. Note: X2 as defined as a depth specific or averaged parameter may move up to six miles or more in a single tidal cycle, and vary significantly on a daily, 14-day, or monthly average with outflow and tidal forces. EC can vary significantly as with X2 but also with depth.

Young Delta smelt being pelagic (open water residing) are at risk to exports from the South Delta under the regular standards and even more so under relaxed standards. Adding higher exports from the water transfers further adds to the risk. Regular without-relaxation conditions occurred as recently as the beginning of May 2014 and are expected to soon revert to the relaxed standard conditions through the summer. Delta smelt young were observed at both the state and federal south Delta export facilities in early May (Smelt Working Group May 12 meeting notes⁵). The process in which young smelt are vulnerable to export is depicted in Figure 4. Early May exports were higher at 2500 cfs than the 1500 cfs of the May 2 State Board Order, because of the San Joaquin River water transfer. Exports of this magnitude, though only about 20% of capacity, draw water south from the central Delta (see my added yellow arrows in Figure 4) to the export facilities (added red circle). Delta outflow in this case was 4000 cfs (the regular standard), slightly higher than that of the 3000 cfs of the relaxed standard. Freshwater inflow in Figure 4 is depicted by my added blue arrows. (Note: freshwater inflow is net inflow and may represent only a small percentage of the actual tidal flows.) Delta smelt collected in the 20-mm Net Survey⁶ are depicted in Figure 4 by green dots. I also added the approximate location of the average 2 ppt salinity level (red line), which is very near the prescribed location of the regular water quality standard. Under the relaxed standards, this standard location (Emmaton) would move upstream to Three Mile Slough (the left most blue arrow). Note the relocation comes about by less freshwater flow coming down the Sacramento River channel at Three Mile Slough resulting in higher average salinity. With less westward transport young Delta smelt would be less inclined to move west to relative safety. With higher exports and more southerly transport, young smelt would be more inclined to move south across the Delta to the export pumps to their demise. Thus Delta smelt are more vulnerable to being drawn toward south Delta exports under the relaxed outflow standard and higher exports allowed under the transfer.

59

⁵http://www.fws.gov/sfbaydelta/documents/smelt_working_group/swg_notes_05-12-2014.pdf

⁶ <http://www.dfg.ca.gov/delta/data/20mm/>

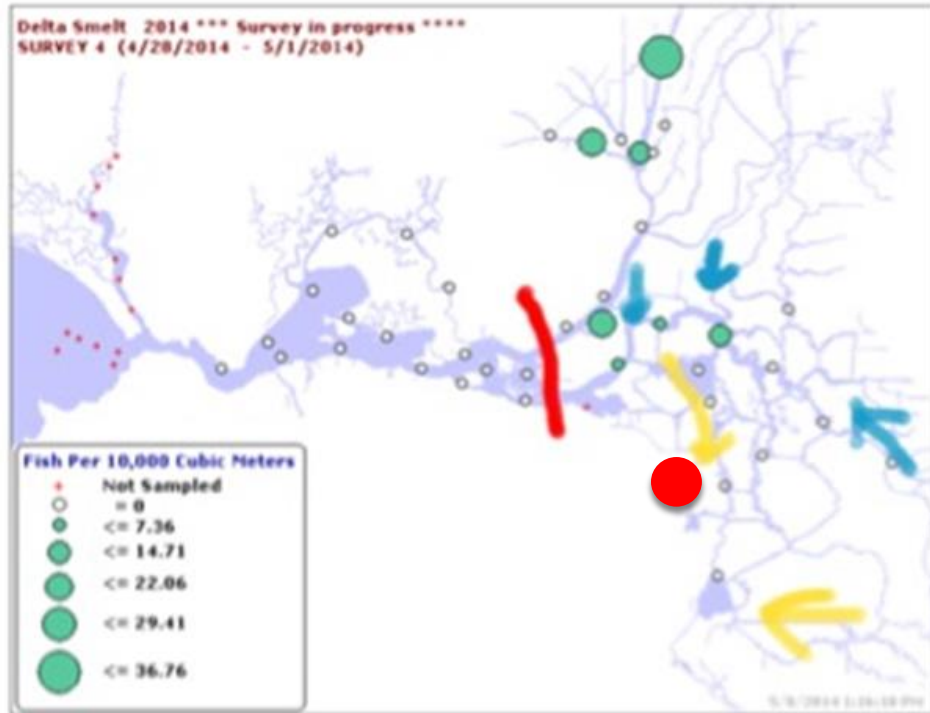

Figure 4. The distribution of Delta smelt young in early May 2014 survey under near-normal conditions (4000 cfs Delta outflow). Blue arrows represent freshwater inflow. Yellow arrows represent reverse flows to south Delta export facilities at red circle. Red line represents the approximate location of 2 ppt salinity.

The young Longfin smelt distribution in the same early May 2014 20-mm Net Survey⁷ depicts a different risk pattern with Longfin concentrated further downstream in the Bay (Figure 5) than Delta smelt (Figure 4). Thus the Longfin were less vulnerable to the south Delta exports under these regular water quality standards (4000 cfs outflow and 2 ppt salinity at Emmaton). However, under relaxed standards with lower outflow (3000 cfs) and 2 ppt salinity at Three Mile Slough, Longfin concentrations would likely be further upstream in the central Delta and more vulnerable to exports. Increasing exports with water transfers would thus increase the risk to Longfin smelt albeit a lesser overall risk than that for Delta smelt.

60

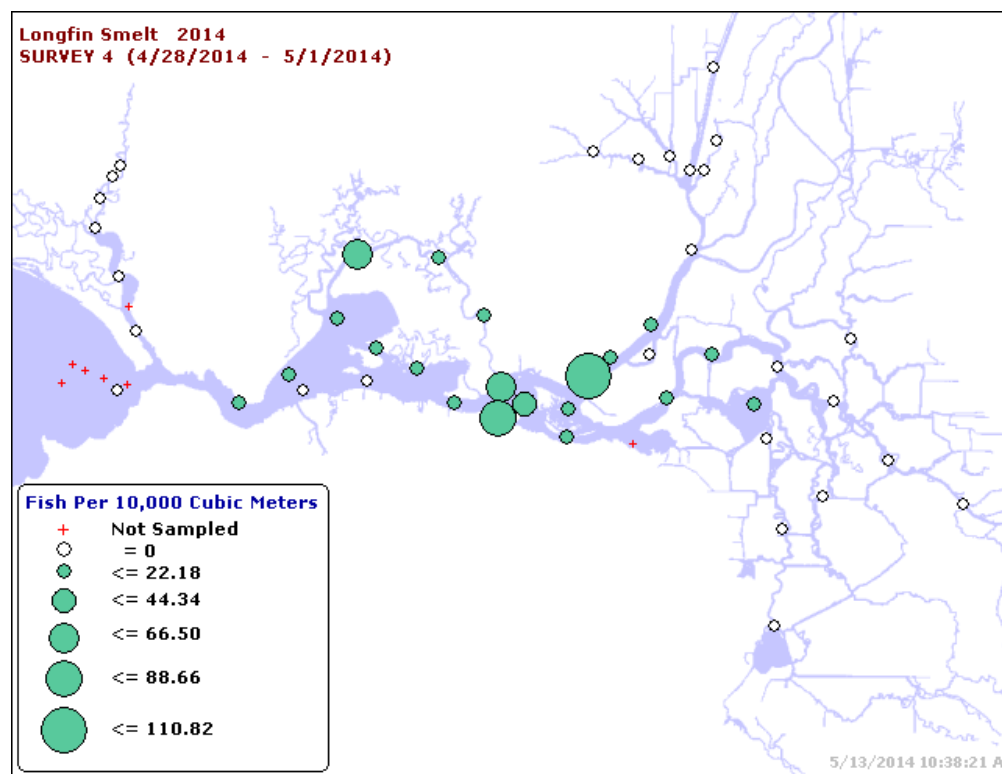

Figure 5. Distribution of Longfin smelt young in early May 2014 survey.

⁷ <http://www.dfg.ca.gov/delta/projects.asp?ProjectID=20mm>

To further characterize the risk to smelt, I also looked at the early summer distribution Delta smelt in recent drought years 2009 (Figure 6) and 2013 (Figure 7). In each case outflows were slightly higher than the standards and Delta smelt were concentrated in the west and north Delta. With a change to the relaxed standards, Delta smelt in these two situations would likely shift with the 2 ppt salinity line (solid red line) upstream to a new location (dotted red line) where Delta smelt would be at much higher risk to south Delta exports. Indeed, Delta smelt were observed in south Delta export fish-salvage collections⁸ in all three periods with the normal standards, low-outflow, low-export conditions (Figures 8, 9, and 10).

61

Smelt Risk Assessment: Summer Delta Conditions per D-1641 Standards: With Transfers

While Reclamation has not requested water transfers to occur under normal (non-relaxed) standards, under the Orders water transfers could be conducted in this manner. Such a situation may arise if higher abandoned flows from rainstorms increase reservoir storage or Delta inflows and thus provide for (allow) exports higher than 1500 cfs. In which case, water transfers would occur as they have in past years. With the addition of transfers, the risks to smelt would increase as exports would increase under the same outflow. Delta outflow requirements would be 4000 cfs or higher, plus the added exports would increase risk as they occur under the transfer rule of 100% of inflow compared to the normal export rule of 65% exports/inflows. It is my opinion that the added risk to Delta smelt from transfers is lower the higher the total exports, because the relative proportion of the transfers declines with increasing exports. Thus, the relative effect of transfers is higher under low exports because the transfers represent a higher relative proportion of the inflows and exports. The risk can be amplified if the federal contractor transfers represent only a portion of the potential transfers being proposed this summer.

62

Smelt Risk Assessment: Summer Delta Conditions per D-1641 Standards: As Relaxed by May 2 Order: With Transfers

To assess the potential risk to Delta smelt of adding summer transfers under relaxed standards I looked at the distribution of Delta smelt in these same surveys from the beginning of summer in recent drought years 2009 and 2013 to ascertain the potential risk to the Delta smelt from increased exports from transfers. It is my opinion that the risk to Delta smelt from transfers is greater under the new relaxed standards. As stated above, the relaxation of outflow from 4000 cfs to 3000 cfs moves the concentrations of Delta and Longfin smelt further to the east where they are more likely to be drawn to the south Delta exports. Adding 15-25% to Delta exports from the water transfers under these low-outflow, low-export conditions adds significantly to the risk. Smelt would be more likely to enter the north-to-south, cross-Delta flow-transport stream to the south Delta exports. It is for this reason that the summer export standard to protect all beneficial uses is 65% of Delta inflows. Allowing water transfers to occur at or very near 100% ignores this basic premise for protecting the beneficial uses including smelt, other fish, and their habitat-foodweb resources. If the federal contractor transfers represent only a portion of the

63

⁸ Note: each of the federal and state pumping plants has fish collection facilities that “salvage” fish prior to entering pump facilities. These fish are collected and trucked to the west Delta. Only a very small percentage of smelt survive the salvage process. Furthermore, many of the smelt that move south in the net flows of the export pumps across the Delta are believed to be lost prior to reaching the export salvage facilities.

potential transfers being proposed this summer, then the risk to Longfin and Delta smelt from higher transfer amounts would be even greater.

63

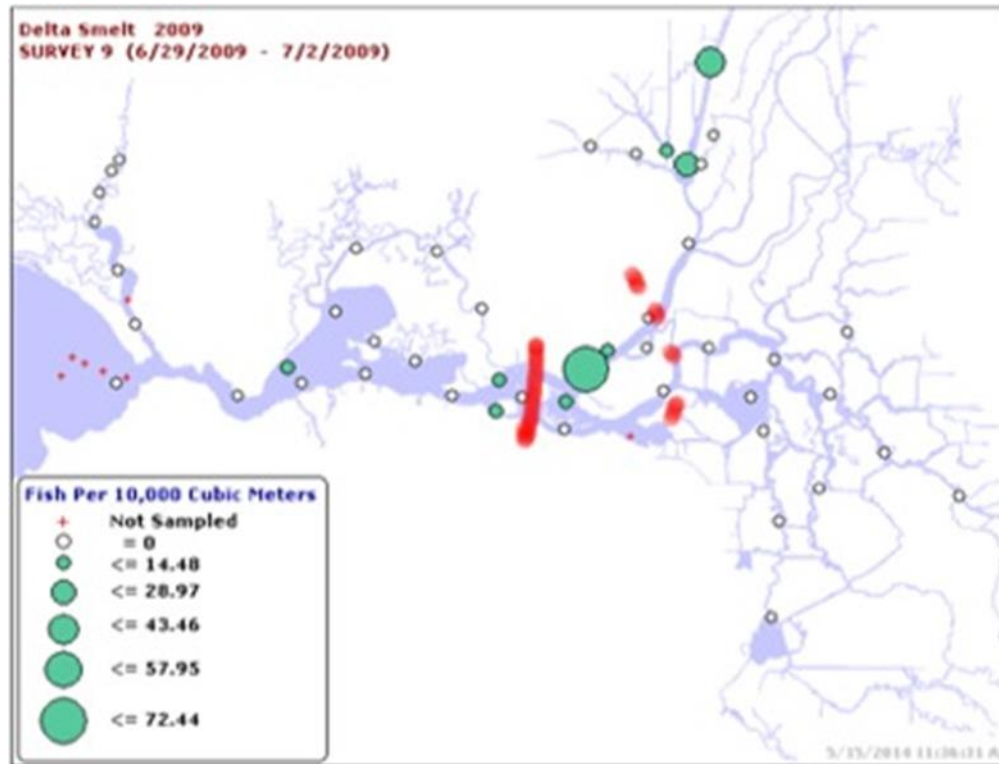

Figure 6. Distribution of Delta smelt from early summer survey in 2009. Red line depicts the approximate location of 2 ppt salinity during the survey. Dotted red line depicts the likely location of 2 ppt salinity with only 3000 cfs outflow under the relaxed standards of the 2014 Orders.

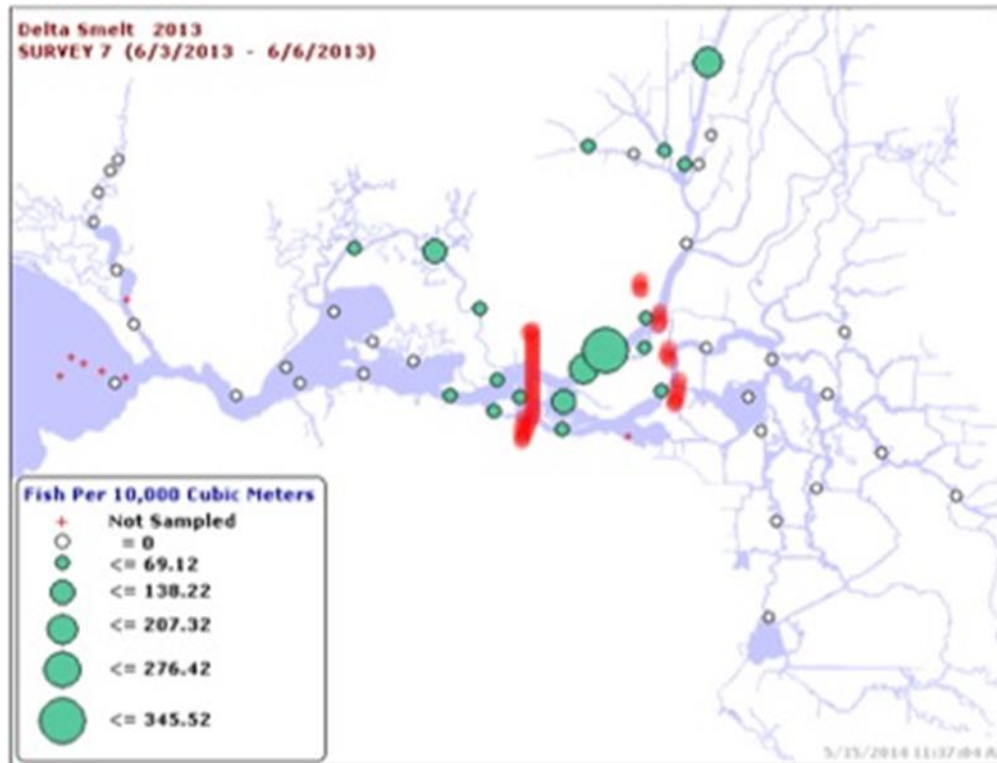

Figure 7. Distribution of Delta smelt from early summer survey in 2013. Red line depicts the approximate location of 2 ppt salinity during the survey. The dotted red line depicts the likely location of 2 ppt salinity with only 3000 cfs outflow of the relaxed standards under the 2014 Order.

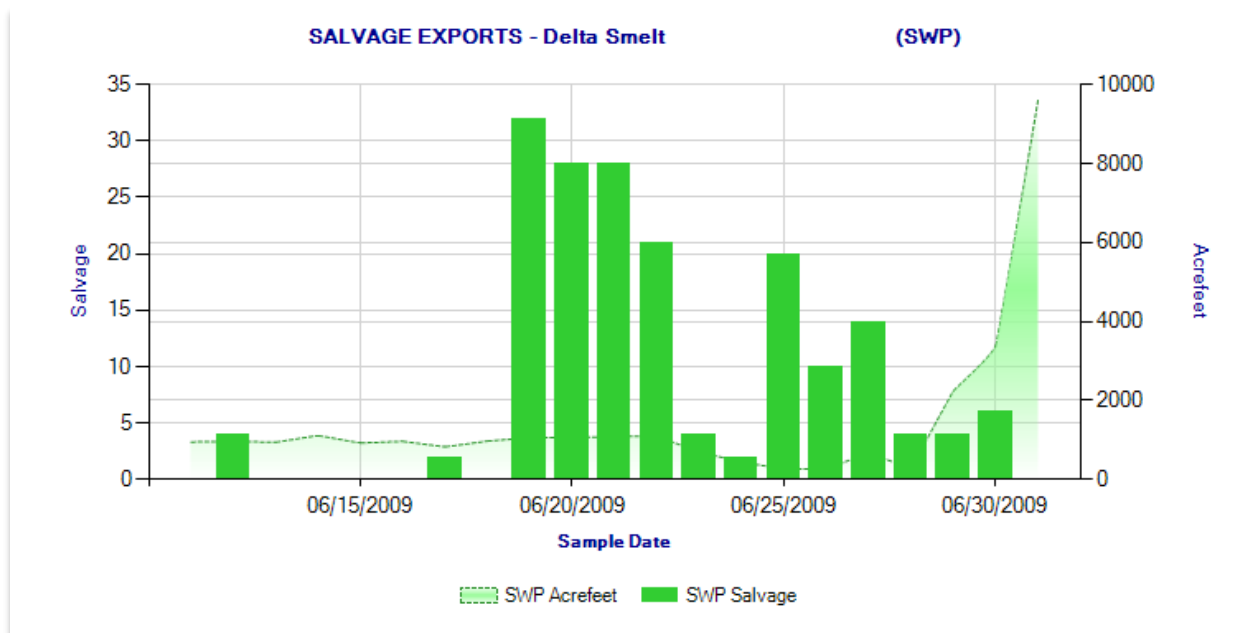

Figure 8. Salvage of Delta smelt at the Clifton Court Forebay fish collection facilities in the south Delta in June 2009. The export rate was less than 1000 cfs during this period of low Delta outflow.

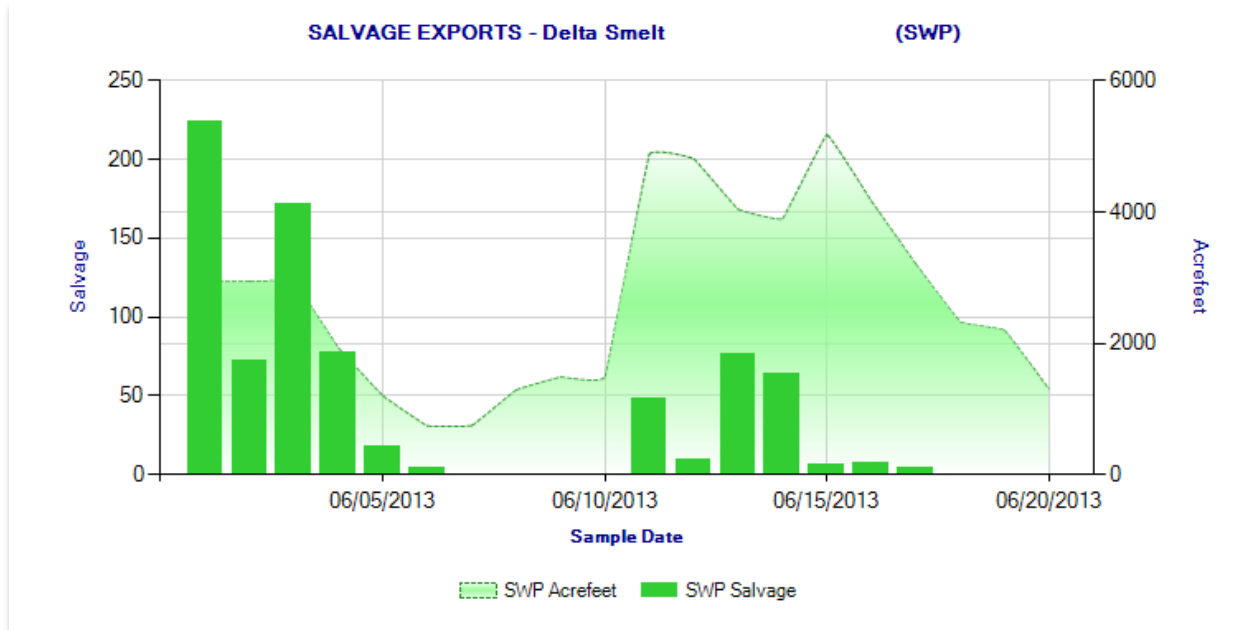

Figure 9. Salvage of Delta smelt at Clifton Court Forebay fish collection facilities in the south Delta in June 2013. The export rate was 500-2500 cfs during this period of low Delta outflow.

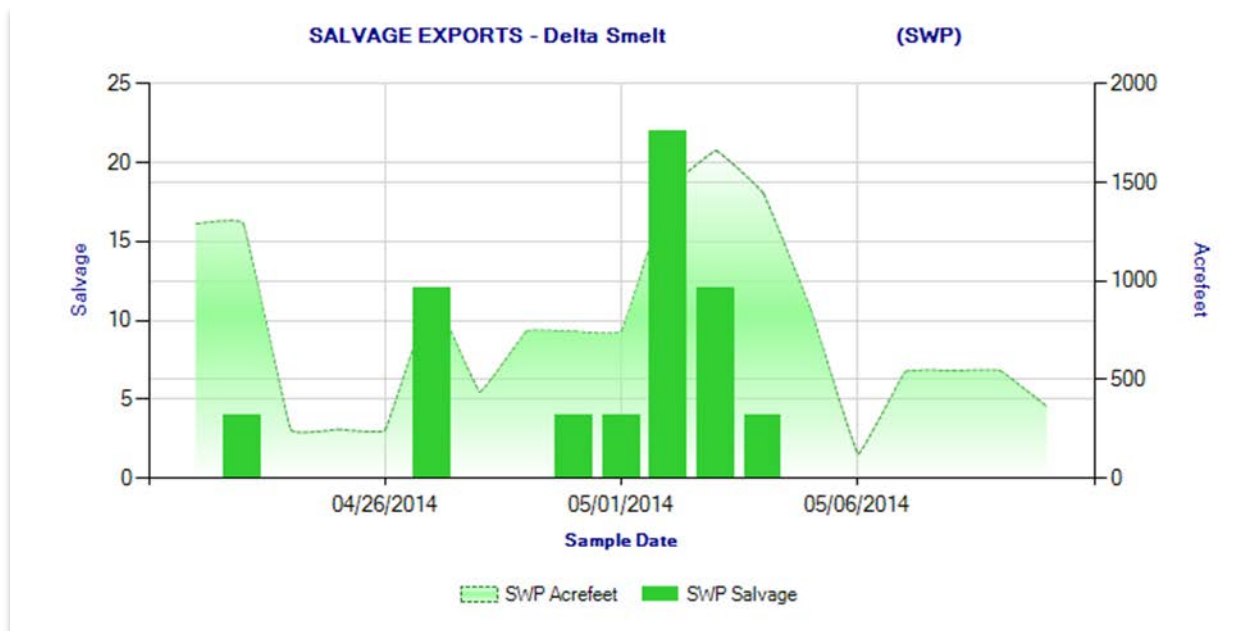

Figure 10. Salvage of Delta smelt at Clifton Court Forebay fish collection facilities in the south Delta in late April and early May 2014. Export rate was less than 3000 cfs during this period of low Delta outflow.

My Answers for Key Questions

In my review and analyses I kept in mind the key questions I was going to address on the potential effects of the Proposed Action:

1. Will water transfers increase the exposure of Longfin or Delta smelt to South Delta Exports?
2. Will water transfers reduce the growth or survival potential of smelt populations?
3. Will water transfers increase the risk of extinction of the smelt species?
4. Would water transfers under D-1641 standards pose a greater risk to smelt than would otherwise occur without water transfers?
5. Would water transfers under D-1641 standards for the transfer period as relaxed per the May 2, State Board Order pose a significant risk to smelt as compared to transfers under normal D-1641 standards for the transfer period?

Opinion on Question 1: Water transfers this summer under normal or relaxed water quality standards would significantly increase the risk to smelt residing in the Delta to being drawn into the south Delta and exported (lost) at the federal and state export facilities.

64

Opinion on Question 2: Water transfers will increase the export of low salinity pelagic habitat; and degrade remaining habitat through increase water temperatures, reduced foodweb productivity, and lower turbidity in smelt nursery areas (from higher river inflows of water transfers); which would reduce growth and survival of Longfin and Delta smelt.

65

Opinion on Question 3: The Delta smelt and Longfin smelt populations are at or near record low index levels. Any further stressors such as higher exports from water transfers on the population would significantly increase the already high risk of extinction. The Bay-Delta population of Longfin smelt risk of extinction though less than that of Delta smelt is also higher because the relaxed standards will shift their population upstream from the relative safety of Suisun Bay into the West and Central Delta where the effects of added transfers will be significantly higher.

66

Opinion on Question 4: Water transfers under normal D-1641 standards and under normal dry year conditions with low Delta inflows, low Delta outflows, and low exports pose a significant risk to smelt because transfers have a higher proportional effect on the conditions. Under 1:1 criteria, transfers increase inflow and exports proportionally over outflow, which increases the risk to smelt.

67

Opinion on Question 5: Water transfers in dry year conditions under relaxed D-1641 standards water quality standards would significantly increase the risk to smelt over that under the normal water standards. With even less outflow and a LSZ being further upstream and well into the cross-Delta flow of export water, transfers pose a much greater risk to the smelt

68

Conclusions

(1) The EA for the 2014 North to South Water Transfers does not present sufficient information to assess the true nature and extent of impacts that water transfers may have on Longfin and

69

Delta smelt. Specifically, the EA does not address the added risk from the changes to the water quality standards requested by Reclamation and approved by the State Water Board.

69

(2) With or without the relaxation of the water quality standards, the transfers are likely to have a significant adverse effect on Longfin and Delta smelt through increased direct loss of young smelt to south Delta exports and indirect loss from degradation of smelt critical habitat by higher water temperatures, lower turbidity, and reduced foodweb productivity.

70

(3) State Board Orders and the April 18 Drought Plan call for changes in Delta water quality standards (D-1641) that increase already high risks to the Bay-Delta ecosystem including Longfin and Delta smelt. Adding water transfers under relaxed standards will add significantly to already high risks.

(3.1) Relaxed outflow standards in summer (reduced outflow from 4000 cfs to 3000 cfs) will reduce the amount of low-salinity habitat in the Delta critical to Longfin and Delta smelt (two listed species that reside primarily in the low salinity zone in late spring and summer), and reduce migration cues for smelt that must pass through the Delta to their fall-winter nursery areas in upper San Francisco Bay. In addition to the decline in area of the low salinity zone, the low salinity zone will be located further upstream (to the east) in the Central and Northern Delta which will result in poor water quality (high water temperatures that may reach lethal levels for smelt, and higher concentration of chemicals including ammonia and pesticides potentially lethal to smelt and their food organisms). Further deterioration of the low salinity zone would occur from higher water temperatures, lower turbidity, and poor Delta foodweb production, as well as the potential upstream expansion of invasive non-native Bay clams. Lower turbidity will reduce smelt growth and survival, and lead to increased predation by non-native fish species on native fish species including smelt. In July there would be no protection for smelt and other pelagic Bay-Delta fish species and their plankton food supply from planned Delta exports that include water transfers. The overall effects will result in potentially dramatic changes to the Bay-Delta endangered fish populations that will last for decades to come.

71

(3.2) The proposed change in the lower Sacramento agricultural water quality standard from Emmaton to Three Mile Slough (necessary under the relaxed lower Delta outflow) will raise Delta salinities and allow further reductions in Delta outflows to the detriment of smelt, salmon, and steelhead. Salinity at Emmaton and Rio Vista in the lower Sacramento River will more than double (EC will go from 2 to 5 millimhos at EMM). Salinity in water exported from the south Delta including transfer water will also be higher with relaxed standards.

(4) Only federal Central Valley Project water transfers were included in the Environmental Assessment. Significant other transfers are possible this summer, thus no adequate cumulative effects assessment was conducted by Reclamation.

72

Veracity of Reclamation FONSI Conclusions

- *“Special status species would not be affected by the Proposed Action beyond those impacts considered by the BOs and current consultations with NMFS and USFWS.”* Neither biological opinion prescribes protection for covered species during the summer. However,

73

both opinions recognize existing water quality standards (mainly 65% export/inflow and Delta salinity standards) as valid protections. (e.g., USFWS BO, pages 29, 128)

- *“Special status fish species are generally not in the Delta during the transfer period (July-September).”* Longfin and Delta smelt both will reside in the Delta under the relaxed water quality standards as they do in most drought years. Nearly the entire Delta smelt population will reside within the Delta this summer with or without the approved changes to the water quality standards.
- *“Effects to these fish species from transferring water during this timeframe were considered in the NMFS and USFWS BOs.”* While water transfers up to 600,000 acre-feet were considered in the BOs, such water transfers were assumed to occur under existing water quality standards, not under the specific relaxed standards of: 3000 cfs outflow; and ag-salinity standard moved 2.5 miles upstream from Emmaton to Three Mile Slough.
- *“Transfers would slightly increase inflow into the Delta, but would not change outflow conditions compared to the No-Action Alternative.”* Delta outflow would be controlled by new relaxed standard of 3000 cfs. Delta inflows from the Sacramento River would increase when Sacramento Valley contractors do not divert their allocated water and instead allow it to pass through to the Delta for export.
- *“The incremental effects of transfers on special status fish species in the Delta from water transfers would be less than significant.”* The incremental effect of transfers will be significant, especially under the conditions expected with relaxed standards.
- *“The Proposed Action will not result in cumulative impacts to any resources previously described.”* The cumulative effect of all transfers would likely have serious consequences to the smelt populations incrementally above that of the relaxed standards. The Proposed Action being one of the potentially larger transfers would have one of the greatest incremental effects.

73

74

75

76

77

78

EXHIBIT 4

Thomas Cannon

5161 Oak Shade Way,
Fair Oaks , CA 95628
916-952-6576
tccannon@comcast.net

June 9, 2014

Tom Lippe
Law Offices of Thomas N. Lippe APC
201 Mission St., 12th Floor
San Francisco, CA 94105

Dear Tom,

At your request, I have reviewed Delta outflows records maintained by the Department of Water Resources to assess whether the outflow measures known as the Net Delta Outflow Index (NDOI) and Net Delta Outflow (NDO) are comparable. My review indicates that in low flow conditions such as July of 2013 and May of 2014, NDOI grossly overestimates actual Delta outflow (see attached charts.)

The comparison is similar to one provided by DWR's for NDOI and NDO for the year 2013 at:

http://www.water.ca.gov/dayflow/docs/2013_Comments.pdf .

In July of 2013, average NDOI was 5,340 cfs, while average NDO was 1,169 cfs. In May of 2014, average NDOI was 3805 cfs, while average NDO was - 45 cfs.

Sincerely yours

A handwritten signature in black ink that reads "Thomas Cannon". The signature is written in a cursive, flowing style.

Thomas Cannon

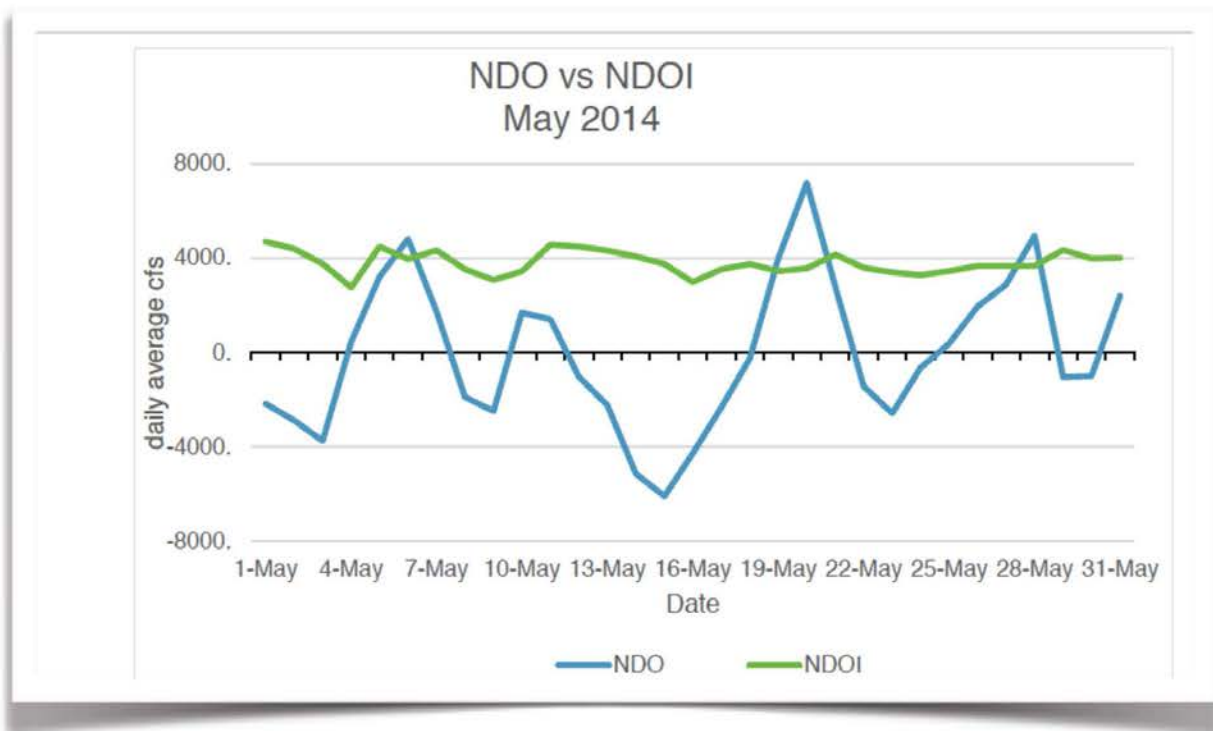
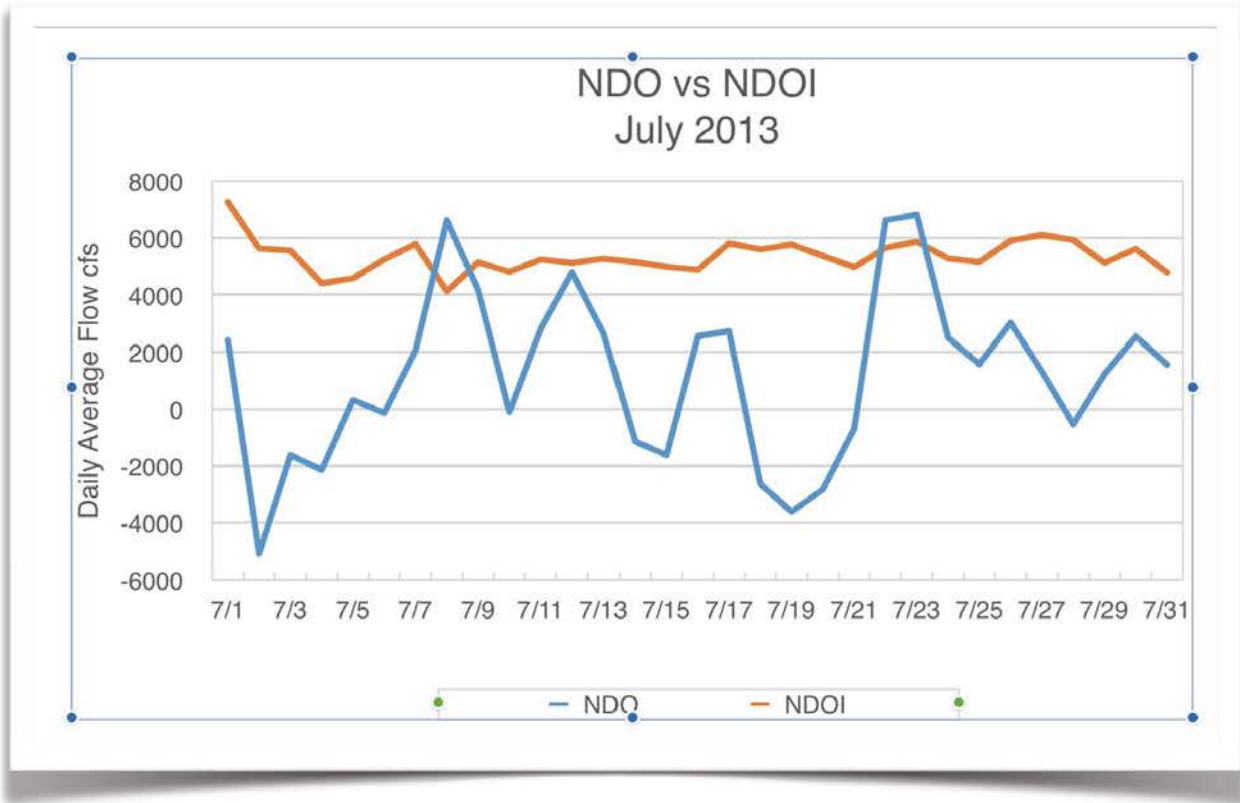

EXHIBIT 5



United States Department of the Interior

BUREAU OF RECLAMATION
 Mid-Pacific Regional Office
 2800 Cottage Way
 Sacramento, CA 95825-1898

IN REPLY REFER TO:

MP-410
 ENV-6.00

JUN 06 2014

Thomas N. Lippe
 201 Mission Street
 San Francisco, CA 94105

Subject: 2014 San Luis & Delta-Mendota Water Authority Water Transfers - NEPA

Dear Mr. Lippe:

Your letter dated May 30, 2014 addressed to Brad Hubbard of my staff was forwarded to me. The Bureau of Reclamation (Reclamation) has reviewed this letter and the Exhibits provided, including Tom Cannon's *Review of Summer 2014 Water Transfers Federal Environmental Assessment Report*. Your letter and Mr. Cannon's report both focus specifically on a claim that the proposed 2014 San Luis & Delta Mendota Water Authority Water Transfers could have significant effects on the Federally listed delta smelt.

Our office solicited the review of Mr. Cannon's report by biologists Ms. Frances Brewster with Santa Clara Valley Water District and Dr. Erwin Van Nieuwenhuysse with Reclamation's Bay Delta Office. The responses we received are provided below.

Ms. Frances Brewster's assessment:

Their arguments make no sense to me.

1. They claim there will be higher mortality due to higher temperatures at 3-mile slough than at Emmaton. That claim is not supported by the data. I compared temps at Emmaton with those at Rio Vista for 7/1/2013 through 10/2/2013 (the transfer window). Rio Vista is considerably further upstream than 3-mile slough, but the 3-mile slough station doesn't have a temp sensor. The average difference in temperature is 0.5 degrees F (n=2173 hourly measurements). That difference in temperature is insignificant. (see attached file)

2. They claim there will be increased entrainment of young-of-the-year due to higher reverse flows. The BiOps have no OMR requirements during the transfer window and in a typical year OMRs can be upwards of -8,000 cfs (easy to pull some real data to support actual OMR during that timeframe). Will the transfers even come remotely close to creating that level of negative OMR (model data ought to be available to support that). There is no BiOp OMR requirements during the transfer window timeframe because entrainment risk is so low based on historic data (the BiOp should provide support for that).

3. Their final claim makes the least sense. They claim that transfer flows will displace plankton rich, higher turbidity water with plankton poor, low turbidity water. How is what is being proposed any different from a normal water year when the projects make reservoir releases for export and to augment outflow?

4. Finally, assuming the amount of LSZ habitat makes a difference, according to FWS the available habitat area (as defined by salinity only) when X2 is at Emmaton versus at 3-Mile Slough is essentially equal. Both areas are within the confined Sacramento River channel around X2=95km (see figure below from BiOp at 374).

Figure B-17. Relationship between X2 and habitat area for delta smelt during fall, with standard shown for wet and above normal years.

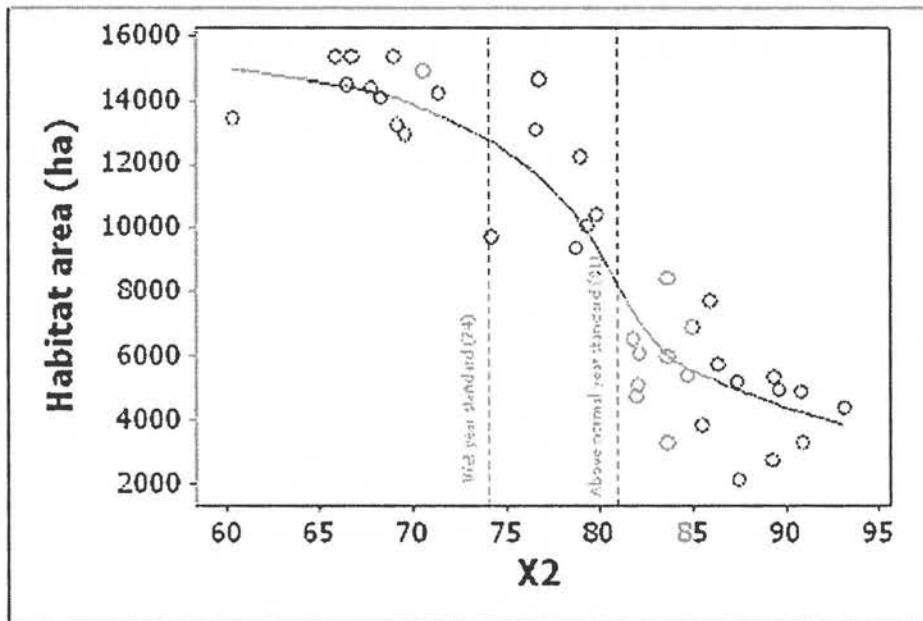

Dr. Erwin Van Nieuwenhuyse's assessment:

I read Tom Cannon's report and Frances Brewster's comments and agree with Frances' assessment. I don't think that Tom's concerns about increased entrainment are warranted given how low OMR flows are expected to be and his concerns about increased water temperature and reduced turbidity and foodweb productivity are also off the mark. As Frances points out, the area of the Low Salinity Zone (LSZ) will not change appreciably and the temperature difference between Emmaton and Rio Vista is negligible. Under these low flow conditions, turbidity in the LSZ is mostly a function of wind-induced sediment resuspension rather than flow. Similarly, I would not expect the proposed water transfers to have any discernible effect on the LSZ foodweb. Most of the smelt population now resides in the Sacramento Deepwater ship channel upstream of Cache Slough. The ship channel offers relatively high food supplies for smelt and is thermally stratified during July-Oct. Our data indicate that temperature in the lower half of the water column (bottom six meters) remains below 23 C during summer-fall. The ship channel is thus a temperature refuge for over-summering fish. By contrast, unless management actions are taken to stimulate a fall phytoplankton bloom in the lower Sacramento River, the LSZ during the water transfer period is likely to remain relatively food-poor with water temperatures at or near the 25 C threshold. I do not think that the proposed transfer would increase the likelihood of delta smelt extinction.

A copy of the spreadsheet file Ms. Brewster provided is enclosed for your reference. Based on these assessments, Reclamation has determined the impacts of the information provided were already covered in the existing EA, so no changes are warranted. Therefore, Reclamation will not be supplementing the Environmental Assessment or preparing an EIS. Please contact Mr. Brad Hubbard, Natural Resources Specialist, at 916-978-5204 or bhubbard@usbr.gov if you have any questions about our reply.

Sincerely,



Richard J. Woodley
Regional Resources Manager

Enclosure

cc: Ms. Frances Mizuno
Assistant Executive Director
San Luis & Delta Mendota Water Authority
P.O. BOX 2157
Los Banos, CA. 93635



Butte Environmental Council

Educating and advocating for the land, air, and water in Northern California since 1975



December 1, 2014

Brad Hubbard (USBR)
Frances Mizuno (SLDMWA)

Subject: Comments, Long-Term Water Transfers (LTWT) Environmental Impact Statement/Environmental Impact Report (EIS/R), September 2014

Butte Environmental Council (BEC) and the undersigned groups and individuals submit the following comments concerning Long-Term Water Transfers. The comments focus on the legal issues surrounding groundwater substitution water transfers and the technical deficiencies found within Section 3.3 and Appendix D of the EIS/R. Concerned citizens of the northern Sacramento Valley recognize that it is long past the time needed to realize the limitations and variability of our natural water supply. We must learn to live within the confines of that system and stop the exploitation of groundwater and strive to improve protections of this critical, fail-safe source of life.

BEC's policy statement regarding water identifies our concerns for Northern Sacramento Valley water resources. Specifically, we believe that citizens should have control over local resources; that Northern California's watersheds must be protected for future generations; and that its ground and surface water must not be exported out of the area to address misuse, waste, and over-allocation elsewhere in California. The undersigned groups and individuals submit these comments holding to one conviction:

The EIS/R should be withdrawn from public circulation until the issues listed herein can be adequately addressed.

1

A leading-edge organization for hydrogeologists and groundwater professionals recently posted an opinion on the declining groundwater conditions across the state.

Thirty-six alluvial groundwater basins that have high degree of groundwater use and reliance may possess greater potential to incur water shortages as result of drought. The basins exist in the North Coast, Central Coast, Sacramento River Tulare Lake, and South Coast hydrologic regions. (Groundwater Resources Association of California, Hydrovisions Summer 2014)

2

Introduction

This EIS/R is inadequate and lacks clarity concerning findings of “no injury to other legal users of the water involved” and “no unreasonable effects on fish and wildlife.” Many of the inhabitants of the northern Sacramento Valley are solely dependent on and are “legal users of water” from the underlying strata, and varying and often disparate aquifer systems of the Sacramento Valley groundwater basin.

Californians have approved millions in bond funding since 2000 for projects that should help her citizens develop and implement strategies to improve water quality, availability, and affordability. These funds should be allocated and spent prior to the development of any project for which the sole objective is focused on ‘supplemental water.’ California’s water supply is over allocated – the very nature of that adjective means that there exists no supplemental water for anyone or anything.

3

1. The LTWT EIS/R is contrary to laws encompassing NEPA, CEQA and California Water Code.

- a. The EIS/R should be withdrawn and rewritten to reflect a programmatic EIS/R.

The very act of invoking Sec 1745. of the California Water Code necessitates a programmatic EIS/R. The document must follow NEPA guidelines for length and tiering as well as detailing the plan for the development and delivery of project level EIS/R(s).

4

NEPA regulation 40 CFR 1502.7 declares that the text of an EIS for “proposals of unusual scope or complexity shall normally be less than 300 pages.” It is impossible for organizations interested in thoughtfully responding to the LTWTP documents to be staffed for a thorough NEPA/CEQA review based on the unreasonable size of the released documentation.

NEPA 40 CFR 6.200(f) To eliminate duplication and to foster efficiency, the Responsible Official should use tiering (see 40 CFR 1502.20 and 1508.28) and incorporate material by reference (see 40 CFR 1502.21) as appropriate.

Associated tiered documentation must be included and show that transfers are consistent with applicable Groundwater Management Plans (GMPs) or, in the absence of a GMP, the transferring water supplier can show a transfer will not create, or contribute to, conditions of long-term overdraft in the groundwater basin.

5

- b. Groundwater substitution transfers are illegal if sourced from most Sacramento Valley groundwater basins

Section 1220 of the California Water Code states that **groundwater cannot be exported from these basins** unless pumping complies with a GMP. It is inadequate to simply list associated GMPs in a table (Table 3.3-1); each GMP listed must be included with the EIS/R documentation set and clearly show approval **'by vote from all counties that lie within'** the Sacramento Valley groundwater basin.

*...states that groundwater cannot be exported from these basins unless pumping complies with a GMP, **adopted by the county board of supervisors** in collaboration with affected water districts, **and approved by a vote from the counties that lie within** the basin. (EIS/R p. 3.3-5)*

According to the CVPIA Section 3405(a), the following principles must be satisfied for any transfer:

- Transfer will be limited to water that would be consumptively used or irretrievably lost to beneficial use;
- Transfer will not have significant long-term adverse impact on groundwater conditions; and
- Transfer will not adversely affect water supplies for fish and wildlife purposes.

Groundwater substitution transfers do not qualify under the intent of the first item. Groundwater substitution transfers involve foregoing the use of surface water and pumping groundwater. But this requires use of a water source that was not or would not be consumptively used given access to surface water rights. Nor is groundwater available that was irretrievably lost to beneficial use. Neither the natural recharge of groundwater nor the 'deep percolation' of excess from applied irrigation water has been defined in California water law as water irretrievably lost to a beneficial use. This first limitation provides **no water** under groundwater substitution transfers by intent of the law.

The EIS/R does not provide any defining characteristics of significant long-term adverse impacts to groundwater conditions and fails to adequately identify the current groundwater conditions of the Sacramento Valley. As such, it is impossible for decision makers to decide if impacts might occur from LTWT and to separate from impacts occurring presently.

The EIS/R fails to quantify the interactions between groundwater and surface water, which is known to be a controversial and difficult process. Lacking an understanding of this set of mechanisms leaves public agencies without the proper tools to assess the adverse affects to water supplies for fish and wildlife purposes under current groundwater usage. Increasing groundwater pumping under the climatic stresses of dry and critically dry water years should be unlawful.

6

7

8

9

2. LTWT and Process Issues

The project description has changed and the EIS/R fails to make this clear. What was stated during and subsequent to the scoping process are in fact no longer correct. It is understood where the 600,000 acre-feet originates. It is the same value that the Bay Delta Conservation Plan promotes. What is not clear is why the May 2011 Scoping Report states an entirely different value than documented within this EIS/R.¹

10

Commenters were concerned that transfers may include up to 600,000 acre-feet of water annually; however, this EIS/EIR will include a much smaller transfer volume (approximately 100,000 to 150,000 acre-feet). [Long-Term Water Transfers: Scoping Report. BOR & SLDMWA. May 2011.]

Federal regulation 40 CFR 1501.1 requires early NEPA integration into planning process prior to the preparation of the EIS emphasizing cooperative consultation among agencies.

11

(b) Emphasizing cooperative consultation among agencies before the environmental impact statement is prepared rather than submission of adversary comments on a completed document.

Either the Bureau has failed to develop an understanding of the hydrologic system of the northern Sacramento Valley and has abused the mandates of NEPA (40 CFR 1501.1(b)); or the California Department of Water Resources, as a responsible agency to LTWT, is complicit in covering the adverse hydrologic conditions existing in the Sacramento Valley present day.

12

- a. Cumulative impact analysis fails to take into consideration all programs present and future.

Sec. 1.7 of the EIS/R lists issues of known controversy, yet the cumulative impacts to Water Supply, Water Quality and Groundwater Resources are missing many critical projects and list projects that will not increase dependence on groundwater resources.

13

The cumulative effects analysis must include all water transfers and programs that result in additional groundwater pumping in the Sacramento region. (EIS/R p. 1-19)

Glenn-Colusa Irrigation District Groundwater Supplemental Supply Project; DWR Future Water Supply Project; and the Bay Delta Conservation Plan currently use groundwater and will increase the exploitation of groundwater supplies from the Sacramento Valley.

- b. The purpose and need behind this project is nebulous and imprecise.

Facilitating water transfers from willing sellers upstream of the Delta to points south of the Delta are illegal, wasteful, and unnecessary; and do not of themselves define a reasonable **purpose** for a project.

14

¹ National Oceanic and Atmospheric Administration Fisheries Service (NOAA Fisheries] 2009) analyze transfers through the Delta from July to September (commonly referred to as the “transfer window”) that are up to 600,000 AF in dry and critically dry years.

*The **purpose** of the Proposed Action is to facilitate and approve voluntary water transfers from willing sellers upstream of the Delta... (EIS/R p. 1-2)*

Water users all over California have a **need** for immediately implementable and flexible solutions to water supply problems. These problems include shortages from inappropriate allocation of natural supplies;² the risks inherent in living in a Mediterranean climate; and poorly envisioned projects that have left behind a wake of environmental destruction and have decimated surface and groundwater supplies.

*Water users have the **need** for immediately implementable and flexible supplemental water supplies to alleviate shortages. (EIS/R p. 1-2)*

No project should be allowed that focuses on the 'needs' of a few. This seems to be the antithesis of the purposes of NEPA and CEQA, which are set in place to ensure protection of the environment and **benefit to the public**. There would be no need for a project if California were to mandate that we live within the means of our natural water supply. The timing and place of water flow has been significantly altered, to the detriment of the environment, throughout California from the construction of dams and canals and use of rivers as modified canals. These countless acts have in turn created a limitation on our water supply. The placement and slowing of water in unnatural environments at unnatural times has resulted in water quickly evaporating or percolating to replenish overdrafted groundwater or both.

The following issues render this EIS/R incomplete; inadequate to mandated findings of "no injury to other legal users" and "no unreasonable effects on fish and wildlife" under NEPA and CEQA; and misleading: these issues preclude meaningful public review.

The EIS/R should be withdrawn from public circulation until the issues listed here can be adequately addressed.

- 1. The Sacramento Valley groundwater basin is inadequately characterized to assess findings of significance under NEPA and CEQA.**
- 2. Well logs included in the EIS/R depict only very shallow aquifers of the region.**
- 3. EIS/R fails to adequately describe the existing hydrologic conditions of the Sacramento Valley.**
- 4. The selection process for a 'reasonable' range of alternatives is biased.**
- 5. Mitigation methods are inadequate to address the significant impacts resulting from project alternatives.**

² Abuse of beneficial use guidelines under California water law – the very nature of moving water from the Delta to points far south is an abuse of the constitutional provisions that prohibit waste and unreasonable use.

BEC incorporates by reference within these comments those of several other correspondents regarding the LTWT.³

16

Discussion

1. The Sacramento Valley groundwater basin is inadequately characterized to assess findings of significance under NEPA and CEQA for the LTWT EIS/R.

The EIS/R inaccurately and detrimentally characterizes the Sacramento Valley as a large, contiguous, and homogenous groundwater basin that extends from a boundary just north of Red Bluff south to the Cosumnes River. The description of depth to base of fresh water essentially paints the aquifer system as one large alluvial-filled 'bathtub.' Inconsistencies exist throughout the EIS/R that understates the complex nature of the aquifer systems that exist within the basin boundaries of the Sacramento Valley. And, statements such as follows, solidify the intention of this document to misrepresent the groundwater system of the Sacramento Valley (see further discussion of this under Issue 3. below).

17

Figure 3.3-8 and Figure 3.3-9 show the location and groundwater elevation of select monitoring wells that portray the local groundwater elevations within the Sacramento Valley Groundwater Basin. (EIS/R p. 3.3.-22)

The EIS/R fails to provide adequate discussions concerning the unique surface hydrology, geologic and hydrogeologic characteristics of the subbasins found within the Sacramento Valley. For example, there exists no mention of the confining layers and varying stratigraphy created under differing formation periods and depositional environments of the Tuscan Formation. The data and analyses incorporated in the EIS/R are cherry-picked, providing a 30,000-foot view of the basin and fails to provide a rigorous definition of the environment and groundwater conditions of the valley today. This oversight results in a suspect analysis. The process of revealing or exposing only what is favorable to the lead agencies shrouds the methodology of the EIS/R, leaving the public and other agencies inadequate tools to assess the results.

2. Selected well logs included in the EIS/R depict only the very shallow aquifers of the region. Inclusion of this data simply shrouds reality, weakening any credence the associated assessment and analysis may have established with this effort.

The six (6) monitoring wells selected to "portray" local groundwater elevations within the northern Sacramento Valley groundwater basin are all very shallow. The average depth to water below ground surface (bgs) ranges between 5' and 45' bgs. While the historical low of any of the wells never exceeded 100' bgs. These wells do not represent the groundwater elevations nor does the discussion surrounding the

18

³ Butte Environmental Council joins with the comments of Tony St. Amant and AquAlliance.

hydrographs represent groundwater condition currently found throughout the northern Sacramento Valley.

Shallow wells shown in the EIS/R may show an endemic decline from underlying aquifers “recovering” water and a long-evolving change in groundwater storage capacity. In the case of confined aquifers, “recovery” might be dewatering the confining layers. Recharge and recovery are not the same hydrologic mechanisms and differ in the ability to ascertain the health of a groundwater production zone. **Recovery of groundwater levels in a production zone is not indicative of a balanced aquifer system.**

Figure 1 shows a significant decline and little recovery that occurred during the summer of 2007. The City of Chico maintains a very steady draw from their groundwater production wells. These hydrographs depict a stress that has altered the efficacy and perhaps the storage capacity of the production zone that these monitoring wells represent. The questions this EIS/R fails to address are considerable. What caused this irreversible change in the groundwater source? What affects does this impact have on the quality of the water sourced from this production zone? What affects will this have on the Central Plume? How many other instances of similar significance have occurred throughout the Sacramento Valley groundwater basin? To what extent will similar impacts occur under the pumping proposed through the LTWT throughout the Sacramento Valley groundwater basin?

18

Central Plume Intermediate and Deep Zone Aquifers
 Semiannual Groundwater Monitoring Report
 Contract No. 11-T1080, Work Order No. 1-020-1.0-100035

Section 3.0
 July 2014
 Page 3-10

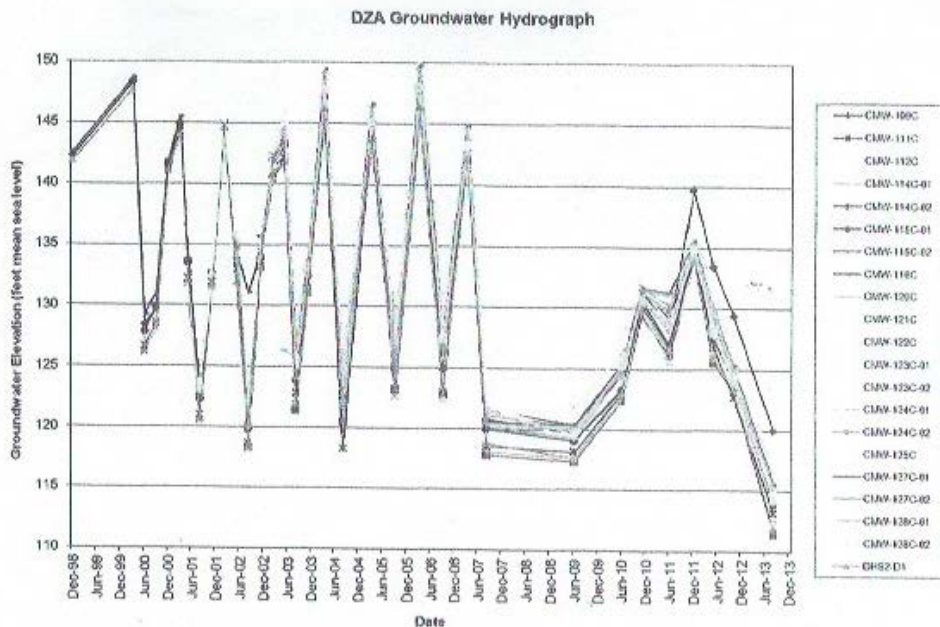

Figure 3-2. DZA Groundwater Hydrograph

Figure 1: Monitoring wells of the Central Plume for intermediate and deep aquifer zones.

19

3. EIS/R fails to adequately describe the existing hydrologic conditions of the Sacramento Valley. Modeling lacks appropriate boundary conditions and fails to evaluate stresses given current and a best assessment of future conditions.

Use of the SACFEM2013 model to simulate stresses on regional surface and subsurface hydrology due to additional groundwater pumping over baseline from groundwater substitution transfers was a useless analysis of the past. Baseline conditions are not delineated and it is unclear if they represent the modeling period or the proposed period for transfers. It is necessary to model impacts under the most accurate assumptions of the hydrologic conditions surrounding the transfer period to understand and mitigate for the most likely range of stresses. The assessment process fails to do just that.

Standard methods of study for groundwater basins are not easily applied to the Sacramento Valley. Standard assumptions cannot account for the hydrogeologic complexity, such as anisotropy, associated with the stratigraphy and range of geologic materials present in the Tuscan, Mehrten and Tehama formations. Numerical groundwater models are intended to help shed light on the possible range of responses a system might exhibit over space and time given predictable changes in stresses. They should not be used to support decisions that may jeopardize the long-term sustainability of water resources of the northern Sacramento Valley.

The following statements from the EIS/R show the vagueness surrounding results of the modeling and analyses. The known or estimated impacts are not clearly quantified or defined making it impossible for public officials to assess potential impacts to their jurisdictions. Specifically, terms like long-term recovery and short-term declines must be defined and quantified for every legal user of water supplies sourced above and below the surface.

...most of the recovery near the pumping zone occurs in the year after the transfer event. Groundwater levels return to approximately 75 percent of the baseline level five years after the single year transfer event in WY 1981 and between 50-75 percent six years after the multi-year transfer event... (EIS/R p. 3.3-70)

...the maximum groundwater level declines resulting from substitution transfers within the Sacramento Valley Groundwater Basin range widely depending on the distance from the transfer groundwater pumping.

Seasonal groundwater level declines would be greater than the typical fluctuation when substitution pumping is included, indicating the potential for adverse effects. (EIS/R p. 3.3-81)

The EIS/R fails to define and quantify the following terms: seasonal groundwater level declines and typical fluctuation (there is nothing typical in the changes experienced presently in this valley, see the decadal groundwater elevation changes in Fig. 2.). What are the “baselines” for the supporting modeling and analyses behind this EIS/R? Were these “baselines” established under climatic and hydrologic conditions of nearly a half century ago?

20

21

The potential for adverse drawdown effects would increase as the amount of extracted water increased. The potential for adverse effects would be higher during dry years, when baseline fluctuations would already be large and groundwater levels would likely be lower than normal. (EIS/R p. 3.3-81)

The EIS/R fails to define and quantify the adverse drawdown effects. What are the differences in stresses to the entire system under dry and critically dry years? It is disingenuous to document, in a time when wells are going dry across the Sacramento Valley, that reduction in well **yields** is the greatest concern the modeling and analyses behind this EIS/R has uncovered.

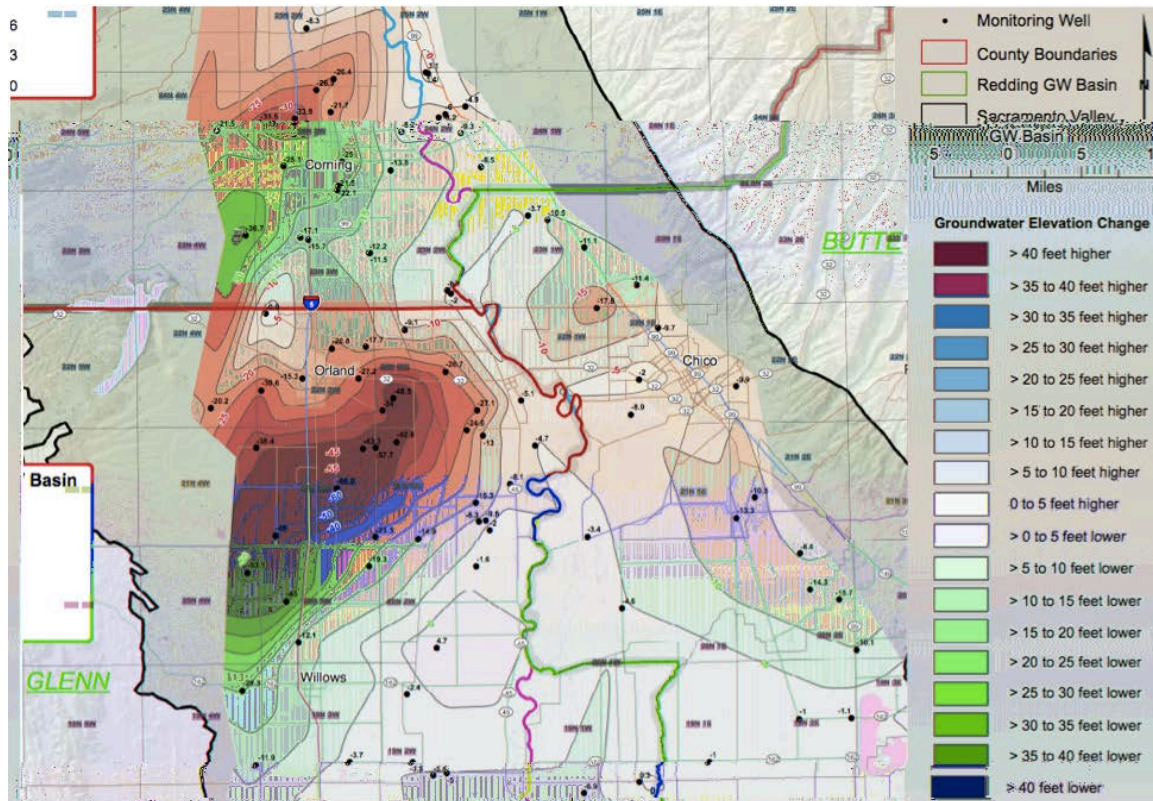

Figure 2: Shallow groundwater elevation changes Summer 2004 to Summer 2014 for well depths 100-450' bgs

4. The selection process for a 'reasonable' range of alternatives is biased.

It appears that alternatives were studied only from the perspective of benefits to water supply and not to the full intent of NEPA and CEQA. The process is unreasonably biased toward the narrow interests of the lead agency SLDMWA and does not adequately protect the region from which the water will be produced. The EIS/R must show substantial treatment, that is **rigorous exploration and objective evaluation**, of all alternatives.⁴

⁴ § 1502.14 Alternatives including the proposed action. This section is the heart of the environmental impact statement. Based on the information and analysis presented in the sections on the Affected Environment (§ 1502.15) and the Environmental Consequences (§1502.16), it should

Metrics used to evaluate alternatives and establish a purpose and need for this project are biased and lack objective criteria (Table 2-1, p. 2-4). Meeting the intent of the CVPIA mandates, such as retiring lands would better serve the entire state and would provide immediate and long-term benefits. All Californians are in need of flexibility in the water supply system during dry or critically dry years. Those of us dependent on groundwater should not fear the extraction of their resource for sale by willing sellers during a time when its use will increase.

Flexibility is not a reasonable or fair metric. There are many other projects the Bureau and SLDMWA can develop to secure the water necessary to meet the needs of the region that are based on hydrologic reality of that region.

Robbing one region of their primary source of water to provide another region with additional water is not a reasonable or fair metric to evaluate alternatives in the context that has been established through this project. For example, Agricultural Conservation in the seller service area somehow meets all three-evaluation metrics while Ag Conservation in the buyer service region does not.

*Immediate: the term proposed for this EIS/EIR is 2015 through 2024. This period is relatively short, and measures need to be able to **provide some measurable benefit** within this time period.*

*Flexible: project **participants need water in some years, but not in others** They need measures that have the flexibility to be used only when needed.*

*Provide **Substantial** Water: project participants need measures that have the capability of providing **additional water to regions** that are experiencing shortages. (EIS/R p. ES-7; 2-3; 2-4; **and** 4-1)*

5. Mitigation methods are inadequate to address the significant impacts resulting from project alternatives.

A 'reasonable range' of alternatives was limited by a poorly defined purpose and the screaming bias inherent in the charters of the lead agencies'.⁵ Environmental impacts and consequences were inappropriately analyzed and lack a fair cumulative analysis. The baseline conditions were not identified or assessed or are nonsense and the existing or known projects dependent on increasing the exploitation of the Sacramento Valley groundwater basin were not included. The EIS/R fails to adequately define the resources that might be impacted: stream flow depletions; irrecoverable groundwater losses; subsidence; and water quality changes in surface and the subsurface. The EIS/R fails to provide a clear line of reasoning in its conclusions related to the direct, indirect, and cumulative impacts. The EIS/R fails to adequately mitigate for potential or known impacts from the project alternatives on the physical, natural, and socioeconomic environment of the region.

present the environmental impacts of the proposal and the alternatives in comparative form, thus sharply defining the issues and providing a clear basis for choice among options by the decisionmaker and the public.

⁵ Comment Letter 1, Tony St. Amant, November 3, 2014 is incorporated by reference.

NEPA requires that mitigation involve:

1508.20 Mitigation. *Mitigation includes: (a) Avoiding the impact altogether by not taking a certain action or parts of an action. (b) Minimizing impacts by limiting the degree or magnitude of the action and its implementation. (c) Rectifying the impact by repairing, rehabilitating, or restoring the affected environment. (d) Reducing or eliminating the impact over time by preservation and maintenance operations during the life of the action. (e) Compensating for the impact by replacing or providing substitute resources or environments.*

Groundwater substitution transfers could decrease flows in neighboring surface water bodies and alter existing subsurface hydrology resulting in a variety of effects to groundwater levels, land subsidence, and groundwater quality. The EIS/ indicates repeatedly that groundwater basins require an unknown amount of time to recharge following a transfer.

The reductions in CVP and SWP supplies are not complete within one year, but can extend over multiple years as the groundwater aquifer refills. (EIS/R p. 3.1-17)

a. Streamflow depletion

Applying a Streamflow Depletion Factor is not a mitigation method (SW-1). It simply and often erroneously identifies how much surface water might be lost due to groundwater pumping. It is a method of charging willing sellers for water the state owns (stream flow) that is assumed to be lost to groundwater pumping. According to Trevor Joseph, DWR, streamflow depletion factors are controversial and little understood with regard to surface and groundwater interactions and the time delays associated with “additional pumping.”

b. Irrecoverable groundwater losses

Dependence on GMPs to reduce the significance of impacts as a result of groundwater substitution water transfers is not an adequate mitigation method (GW-1). In 2014, DWR and the California Water Foundation performed separate studies to assess the current state of groundwater management planning in California. Both organizations found GMPs lacking mandated components necessary to promote good groundwater management practices and monitor groundwater levels. DWR found plans that include all California Water Code requirements cover just 17% of the groundwater basins defined in Bulletin 118.⁶

⁶ Many plans lacked basic basin management objectives (BMOs), such as groundwater level or quality thresholds. Groundwater data, crucial for effective management, is lacking in many groundwater basins. There has been slight improvement in the plans since the passage of SB 1938, which requires specific elements to be included in a GMP in order for an agency to be eligible for certain DWR funding. However, most plans did not contain an implementation strategy for ensuring that BMOs, when articulated, will be met. Stakeholder outreach and participation was either non-existent or not described adequately in many, if not most, of the plans. Additionally, 28% of the plans were written in 2002 or earlier and have not been updated.

An Evaluation of California Groundwater Management Planning, California Water Foundation, July 2014

25

26

c. Subsidence

The potential for serious impacts due to subsidence are clearly defined by DWR's latest report.⁷ The fact that this report is not referenced is problematic, shedding more light on the egregious analytical shortcomings of this EIS/R.

Groundwater extraction for groundwater substitution transfers would decrease groundwater levels, increasing the potential for subsidence. Most areas of the Sacramento Valley Groundwater Basin have not experienced land subsidence that has caused impacts to the overlying land. (EIS/R p. 3.3-82)

27

d. Water quality

The environmental assessment surrounding the LTWT completely ignores groundwater quality issues. There are numerous plumes throughout the Sacramento Valley for which the Department of Toxic Substance Control has oversight.

28

Conclusion

The EIS/R should be withdrawn from public circulation; and

The EIS/R should be modified to:

Reflect the elements and requirements of a programmatic EIS/R, strictly adhering to page limitations and tiering of appropriate project level environmental documentation; and

29

Reflect a legally appropriate lead agency, such as a group of agencies, including SLDMWA and the counties that overlie the DWR Bulletin 118 groundwater basins and confined (deeper) aquifers from which groundwater substitution transfers may occur, organized into a cooperative effort by contract, joint exercise of powers, or similar device.⁸

Sincerely,

Robyn Difalco
Executive Director
Butte Environmental Council

Carol Perkins
Water Policy Advocate
Butte Environmental Council

⁷ Summary of Recent, Historical, and Estimated Potential for Future Land Subsidence in California, CA Department of Water Resources, October 2014.

⁸ 14 CCR § 15051 (d).

cc: Nancy Quan, State Water Project Analysis Office
Debbie Davis, Office of Planning and Research
John Laird, Secretary – California Natural Resources Agency
Craig McNamara, President – California Department of Food and Agriculture
Karen Ross, Secretary– California Department of Food and Agriculture
Matthew Rodriguez, Secretary – California Environmental Protection Agency

December 1, 2014

Mr. Brad Hubbard
Bureau of Reclamation
2800 Cottage Way, MP-410
Sacramento, CA 95825



Re: California Waterfowl Association Comments on the Draft EIS/EIR on Proposed Long-Term Water Transfers

Delivered by email.

Dear Mr. Hubbard:

Thank you for the opportunity to comment on the draft EIR/EIS on Proposed Long-term Water Transfers. The California Waterfowl Association is a statewide nonprofit organization whose principal objective is the conservation of the state's waterfowl, wetlands, and hunting heritage. California Waterfowl believes hunters have been the most important force in conserving waterfowl and wetlands. California Waterfowl biologists are leading experts on designing, operating, and maintaining managed wetlands throughout California, including the Sacramento/San Joaquin River Delta and the Suisun Marsh.

Since 1945, California Waterfowl has been active in creating and maintaining managed wetlands habitats for migratory waterfowl, including ducks and geese. Because of the loss of 95 percent of the historical wetlands in California, the remaining wetlands, two-thirds of which are in private ownership, have to be intensively managed to provide the optimum habitat value for migratory waterfowl. While not listed under the state or federal endangered species acts, migratory waterfowl are protected by legislation or treaty, including the North American Wetlands Conservation Act (NACWA) and the international Migratory Bird Treaty.

The state and federal governments and private landowners such as farmers and duck clubs have invested millions of dollars in managed wetlands for the primary benefit of migratory waterfowl. These managed wetlands also benefit a variety of other bird species, as well as reptiles, fish, and mammals. They use natural and artificial water flows to flood wetlands, and then use developed infrastructure to hold and drain floodwaters as appropriate to provide food resources and suitable seasonal habitat.

California Waterfowl has reviewed the Draft EIR/EIS on proposed long-term water transfers. As proposed in the current drafts, long-term water transfers could have significant and unavoidable impacts on wetland and waterfowl resources in the Sacramento and San Joaquin. Section 3.8 of Chapter 3 discusses environmental impacts to terrestrial resources from the water transfers. California Waterfowl's main concern is with the natural communities and agricultural habitats in the sellers' service area identified in Section 3.8.1.3.1. California Waterfowl is primarily interested in impacts arising from Alternatives 2, 3, and 4.

In California Waterfowl's estimation, the greatest impacts to migratory waterfowl would result from cropland idling and shifting transfers, as discussed in Section 3.8.2.1.2. Migratory waterfowl depend

1

heavily for food resources on the post-harvest and winter flooding of rice fields for decomposition of rice stubble. Section 3.8.2.1.2 correctly identifies the impacts of cropland idling and shifting transfers on migratory waterfowl. The idling of cropland and the shifting of water will deprive waterfowl of food resources and habitat. However, as also pointed out at the top of page 3.8-35, fallowing of fields provides an opportunity to develop nesting habitat.

1

California Waterfowl was the sponsor of a bill in the state Legislature that declares it is the policy of the state to encourage the planting of dry cover crops on fallowed fields for the purpose of providing nesting habitat for local, resident birds, such as mallards. SB 749 (Wolk – Chapter 387, Statutes of 2013) requires the Department of Water Resources to provide guidelines to landowners on how to create and maintain nesting cover for resident waterfowl and other birds on fallowed lands. The EIS/EIR should include a requirement of this type of affirmative action to mitigate for the loss of habitat from fallowed fields.

2

Please contact me at (916) 217-5117, or at jvolberg@calwaterfowl.org if you would like further information on this suggested mitigation activity.

Sincerely,



Jeffrey A. Volberg
Director of Water Law & Policy

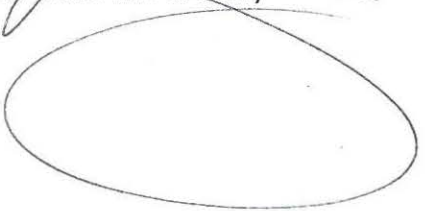



CENTER *for* BIOLOGICAL DIVERSITY

Sent Via Email to: bhubbard@usbr.gov

December 1, 2014

Brad Hubbard
 U.S. Bureau of Reclamation
 2800 Cottage Way
 Sacramento, CA 95825

RE: Central Valley Project Long-term Water Transfers Draft Environmental Impact Statement/Environmental Impact Report

Dear Mr. Hubbard:

These comments are submitted on behalf of the Center for Biological Diversity (Center) regarding the Central Valley Project (CVP) Long-term Water Transfers Draft Environmental Impact Report/Environmental Impact Statement (DEIR/EIS).

The Center for Biological Diversity is a national, nonprofit organization with nearly 158,000 members and activists in California who are dedicated to the protection of endangered species and wild places. The Center has worked to protect and restore endangered species and their habitats in the Sacramento River and San Joaquin River watersheds since the late 1990s.

The proposes water transfers would export water from the Sacramento and San Joaquin regions to the Bay Area and Central Valley from 2015-2024 (Project). The Project would occur through methods including reservoir releases, groundwater substitution, and crop idling/shifting. These water transfers would drain both surface and groundwater resources from the Sacramento River and San Joaquin River watersheds (Exporting Areas), imposing significant and irreversible threats to the sensitive species that rely on these water resources and associated aquatic and riparian habitats to survive. However, the DEIR/EIS fails to establish an adequate baseline by which to assess Project impacts, fails to adopt an acceptable methodology for accurately determining existing conditions and potential Project impacts, and fails to sufficiently assess or provide adequate measures to minimize or mitigate the impacts on sensitive species and their habitats within the Exporting Areas.

1

Reservoir Releases

The DEIR/EIS concludes that reservoir releases will have less than significant impacts on natural communities and special-status species since they would not reduce

2

reservoir storage in Export Areas by more than 10% during normal to wet water years. (DEIR/EIS, at 3.8-47.) In particular, the DEIR/EIS concludes that, with the exception of Bear River, reservoir releases from the Project under the Proposed Action would reduce surface water flows by less than 10% and therefore less than significant levels in the Sacramento River watershed. (DEIR/EIS, at 3.8-49.) The 10% threshold of significance appears arbitrary since it does not correspond with the significance criteria established, and does not refer to other sections of the DEIR/EIS. (DEIR/EIS, at 3.8-49.) Additionally, the DEIR/EIS unreasonably assumes there would be sufficient surface water flows within the Exporting Areas for the 10% drawdown during drought periods.

2

The DEIR/EIS also lacks historic flow data on twenty-one smaller rivers that would be impacted by the Project. (DEIR/EIS, at 3.8-51.) Therefore the DEIR/EIS fails to provide sufficient information regarding existing conditions in order to establish an adequate baseline for assessing impacts. Consequently, the DEIR/EIS cannot accurately assess potential Project impacts or provide mitigation measures without first establishing a baseline of existing conditions from which to analyze.

3

The DEIR/EIS also estimates that since the Project would reduce surface water flow and Delta outflow but therefore would have no significant biological impacts. (DEIR/EIS, at 3.8-62; 3.7-12.) However, the DEIR/EIS provides inadequate data to support these conclusions. The Project will likely result in significant impacts to listed fish species including Chinook salmon and Central Valley steelhead, green and white sturgeon, and Delta and longfin smelt. For instance, the DEIR/EIS states that water transfers would coincide with the spawning period of winter-run Chinook salmon and could alter stream flow and temperature in the upper Sacramento River. (DEIR/EIS, at 3.7-12.) Yet the DEIR/EIS concludes that the Project would not result in significant effect on this and other species based simply on the 10% flow reduction criteria. (DEIR/EIS, at 3.7-25.)

4

Additionally, the DEIR/EIS admits that the Project would reduce reservoir waters by 18.2% during critically dry years in August and September. (*Id.*) These drawdown estimates during critically dry years such as this year are unacceptable since there will unlikely be sufficient water for the Project to operate without depleting the entire reservoir storage during drought periods. The DEIR/EIS is thus misleading by claiming that reductions in reservoir storage would be less than significant *over all*, while downplaying the fact that drawdown during critically dry years like this one would be significant and likely infeasible.

5

Groundwater substitution transfer

First, the data that the DEIR/EIS relies on to assess groundwater substitution impacts on stream water is severely outdated. The impacts of groundwater substitution transfer on stream water depletion was calculated based on data on water export availability in the Region from 1970 to 2003 (DEIR/EIS, at 3.8-38.) This method fails to

6

include data that reflect *reduced* exports based on current water realities or regulatory constraints including the 2008 and 2009 biological opinions. Thus the DEIR/EIS fails to establish an adequate baseline by which to assess Project impacts.

6

Similarly, criteria that the DEIR/EIS adopts to evaluate groundwater substitution impacts on surface waterways are also flawed. DEIR/EIS dismisses small waterways near modeled groundwater transfer areas as not warranting further modeling if water flow for these small waterways will be reduced by 1 cubic-foot per second or 10% since “the effect was considered too small to have a substantial effect on terrestrial species.” (DEIR, at 3.8-38.) This appears to be an arbitrary threshold of significance for evaluating impacts on small waterways since it does not correspond with significance criteria on 3.8-43 and the DEIR/EIS does not refer to other sections of the document for support. (DEIR, at 3.8-43.) The DEIR/EIS also fails to discuss how groundwater substitution would affect aquatic species in small waterways. A 1 cubic-foot per second reduction in water flow could affect both aquatic and terrestrial species especially in drought periods.

The Project would increase groundwater pumping for irrigation in the Exporting Areas to substitute surface water that would be exported, which the DEIR/EIS states could result in a reduction in a level of groundwater in the vicinity of pumps. (DEIR/EIS, at 3.8-31.)

7

However, the DEIR concludes that groundwater drawdown from increased will be less than significant since groundwater modeling results indicate that shallow groundwater is typically deeper than 15 feet in most locations under existing conditions and not associated with groundwater-dependent ecosystems. Even if species such the valley oak rely on deeper groundwater, the DEIR/EIS states groundwater drawdown impacts to these species to be minimal by asserting that “these species have further adapted to California’s Mediterranean climate of wet winters and hot dry summers.” (DEIR, at 3.8-32.) The DEIR/EIS concludes that groundwater drawdown under the Proposed Action would have less than significant impacts on natural communities and special-status plants. (DEIR/EIS, at 3.8-47.) The only justification the DEIR/EIS affords in reaching this conclusion is that “Plants within these communities would be able to adjust to the small reductions in groundwater levels because the draw down is expected to occur slowly through the growing season, allowing plants to adjust their root growth to accommodate the change.” (*Id.*) These assertions are not supported in the DEIR/EIS.

The DEIR/EIS further dismisses the negative impacts of groundwater drawdown that would result from the Project on riparian ecosystems, stating that “Because of the interaction of surface flows and groundwater flows in riparian systems, including associated wetlands, enables faster recharge of groundwater, these systems are less likely to be impacted by groundwater drawdown as a result of the action alternatives.” (*Id.*) This statement ignores the fact that Exporting Areas will take a double hit of reduce surface *and* groundwater resources. The DEIR/EIS also inappropriately assumes that there would be sufficient surface waters would to recharge groundwater, ignoring that

8

this is not the case during drought periods. In addition, surface and groundwater resources in the Sacramento region are highly interconnected. (Howard 2010.) Therefore any drawdown of surface water or groundwater would very likely impact the level of the other. Given the Exporting Area's high surface and groundwater connectivity the DEIR/EIS fails to accurately address the likelihood that reducing surface water flow will reduce groundwater recharge potential in the area.

8

The DEIR/EIS would require implementing entities to adopt monitoring program and mitigation plans to alleviate impacts from groundwater substitution transfers. (DEIR/EIS, at 3.3-88 to 3.3-91). However, these measures are inadequate to minimize and mitigate the significant impacts that would result from groundwater drawdown since they do not provide sufficient information for decision-makers or the public to be able to ascertain whether they would be effective or enforceable. In particular, the DEIR/EIS fails to require monitoring and reviewing the impacts groundwater pumping on connected surface waters and groundwater-dependent ecosystems. Furthermore, the DEIR/EIS inappropriately defers the responsibility for developing specific mitigation plans as well as criteria for significance to each individual seller. (DEIR, at 3.3-90.)

9

Finally, the DEIR/EIS fail to and should be revised to address how it would comply with existing groundwater management plans in the Exporting Areas as well as the statewide groundwater legislation that will be in effect beginning January 1, 2015.

10

Cropland idling/shifting

The Proposed Action would allow idling/shifting of 8,500 acres of upland cropland and 51,473 acres of seasonally flooded agriculture. (DEIR/EIS, at 3.8-63 and 3.8-64.) The DEIR/EIS recognizes that cropland idling/crop shifting would potentially affect some wildlife species that depend on cropland for foraging and/or depend on habitat associated with cropland and managed agricultural lands, as well as downstream habitat dependent upon agricultural flow returns. (DEIR/EIS, at 3.8-33.)

However, the DEIR/EIS states without support that "bird species that would be potentially affected by idling of upland crops would be capable of dispersing to other areas or other non-idled parcels." (*Id.*) The DEIR/EIS unreasonably assumes that migratory birds will still be able to find adequate food in years when upland crops are fallowed for transfers. However, in drought years, birds are already stressed by lack of food availability. Additionally, the DEIR/EIS itself recognizes yet fails to take into account that birds with limited distribution and specific breeding and foraging requirements including the greater sandhill crane and black tern will not adapt to crop idling/shifting. (DEIR/EIS, at 3.8-26 to 3.8-27.)

11

The DEIR/EIS also admits that crop idling/shifting could contribute to habitat fragmentation by preventing species or moving between areas. (DEIR, at 3.8-35.) The DEIR/EIS acknowledges that the "distribution of these water year types within the action

12

period is unknown. Additionally, the exact locations of cropland idling/shifting actions would not be known until the spring of each year, when water acquisition decisions are made.” (DEIR/EIS, at 3.8-35.) The DEIR/EIS does not have or provide sufficient information regarding where/when crop idling/shifting will take place, and therefore cannot calculate the potential for habitat reduction and fragmentation will result from crop idling/shifting activities. Yet the DEIR/EIS concludes that “because crop rotation and idling are standard practices, species that reside in agricultural areas adjust to these types of activities.” (*Id.*) This statement is not supported by fact and contrary to the DEIR/EIS’ previous statements regarding recognizing habitat fragmentation as a threat to species survival. (DEIR/EIS, at 3.8-33 to 3.8-35.)

12

The DEIR/EIS provides that upland crop idling/shifting would not impact migratory bird populations since there are other areas to forage and species will adapt by looking for other forage areas. (DEIR/EIS, at 3.8-63.) As discussed above, the DEIR/EIS does not adequately address the significant adverse impacts that would result from these activities. The DEIR/EIS also does not provide any measures to mitigate these impacts. Instead, the DEIR/EIS simply states that “cropland idling decisions would be made early in the year before the general breeding season of most birds that have the potential to occur in the area of analysis,” without providing further detail on if or how these decisions would reduce impacts to bird species (DEIR, 3.8-63.)

The DEIR/EIS provides that proposed environmental commitments would reduce potential impacts to seasonally flooded cropland idling/shifting to less than significant by ensuring canals bordering rice parcels continue to carry water even when adjacent parcels are idled. (DEIR/EIS, at 3.8-65, 3.8-67.) The DEIR/EIS assumes that watered canals provide sufficient habitat for bird species, and fails to explain how these canals would sufficiently make up for the nearly 51,500 acres of habitat for migratory birds and other birds including the tri-colored blackbird, western pond turtle, giant garter snake, and other protected and sensitive species that would be lost due to fallowing the rice parcels.

13

This Project will only worsen those existing conditions under the drought, and inadequate mitigation is proposed to mitigate the significant resulting impacts to migratory birds and other species that currently rely on agricultural lands for survival.

Conclusion

Thank you for the opportunity to submit comments on this proposed Project. We look forward to working to assure that the Project and environmental review conforms to the requirements of state and federal law and to assure that all significant impacts to the environment are fully analyzed, mitigated or avoided. In light of many significant, unavoidable environmental impacts that will result from the Project, we strongly urge the Project not be approved in its current form. Please do not hesitate to contact the Center with any questions at the number listed below. We look forward to reviewing the U.S.

14

RE: CVP Long-term Water Transfer DEIR/EIS
December 1, 2014
Page 6 of 7

Bureau of Reclamation's responses to these comments in the Final EIR/EIS for this Project once it has been completed.

14

Sincerely,



Chelsea Tu
Staff Attorney, Urban Wildlands Program

REFERENCES

Howard J, Merrifield, M. (2010). Mapping Groundwater Dependent Ecosystems in California. *Available at:*
<http://www.plosone.org/article/info%3Adoi%2F10.1371%2Fjournal.pone.0011249>.

Buckman, Carolyn

From: HUBBARD, BRADLEY <bhubbard@usbr.gov>
Sent: Thursday, October 23, 2014 5:00 PM
To: Buckman, Carolyn; Veronese, Gina; Frances Mizuno
Subject: Fwd: Question regarding Long-Term Water Transfers Draft EIS-EIR

----- Forwarded message -----

From: **Rachel Zwillinger** <RZWILLINGER@defenders.org>
Date: Thu, Oct 23, 2014 at 4:58 PM
Subject: Question regarding Long-Term Water Transfers Draft EIS-EIR
To: "bhubbard@usbr.gov" <bhubbard@usbr.gov>

Hi Brad,

I have a quick question about the Long-Term Water Transfers Draft EIS-EIR. Section 6.2.3 of the draft states that "Reclamation will submit a Biological Assessment for USFWS review under Section 7 of the Federal Endangered Species Act." Will there be a single biological opinion that covers all of the transfers that are analyzed in the Draft EIS-EIR? And do you have any sense of when the Section 7 analysis will occur?

1

Thanks,

Rachel



Rachel Zwillinger
Water Policy Advisor

Defenders of Wildlife
1303 J Street, Suite 270, Sacramento, CA 95814
Tel: (415) 686-2233
rzwillinger@defenders.org | www.defenders.org

--
Thanks,
Brad



California Office
1303 J Street, Suite 270 | Sacramento, CA 95814 | tel 916.313.5800 | fax 916.313.5812
www.defenders.org

December 1, 2014

Brad Hubbard
U.S. Bureau of Reclamation
2800 Cottage Way, MP-410
Sacramento, CA 95825

Sent via U.S. Mail and via email to bhubbard@usbr.gov.

Re: Comments on the Long-Term Water Transfers Draft Environmental Impact Statement / Environmental Impact Report

Dear Mr. Hubbard:

On behalf of Defenders of Wildlife, which has approximately 1,200,000 supporters and members, 180,000 of whom are Californians, we are writing to provide comments on the Long-Term Water Transfers Draft Environmental Impact Statement/Environmental Impact Report (“Draft”). We are sympathetic to the fact that management decisions involving water transfers need to occur quickly, and believe that an Environmental Impact Statement (“EIS”)/Environmental Impact Report (“EIR”) covering an extended time period could be beneficial. However, the Draft suffers from several fundamental flaws that undermine its ability to provide information regarding the environmental impacts of the proposed long-term water transfers, and that render the document legally inadequate.

First, the Draft includes several “environmental commitments” intended to avoid significant impacts that could be caused by crop idling transfers. These commitments, however, are inadequate to protect the threatened giant garter snake and bird species that depend upon agricultural lands in the project area. Because significant environmental impacts will remain after implementation of the proposed commitments, we have suggested additional environmental commitments that should be included either as part of the project description, or as mitigation measures. Second, the Draft entirely fails to analyze the proposed water transfers’ impacts on waterfowl, shorebirds, and south of Delta refuges, although the impacts to these public trust resources could be profound. Third, the Draft uses an arbitrary and not biologically-based screening threshold to avoid analyzing the impacts that flow reductions caused by the proposed transfers could have on fisheries and sensitive terrestrial species. The Draft also fails to account for climate change impacts in its operational modeling, does not consider an adequate range of alternatives, and fails to include foreseeable projects in its cumulative impacts analysis.

*Comments on Long-Term Water Transfers Draft EIS/EIR
December 1, 2014*

These deficiencies and the others that we describe below are so substantial that we believe the Bureau of Reclamation (“Reclamation”) and the San Luis & Delta-Mendota Water Authority (“SLDMWA”) should issue a revised draft EIS/EIR for the proposed long-term water transfers. Remedying the problems in the current Draft will require modifications to the proposed action and significant new analysis, and the public and the project proponents would benefit from another round of review before the document is finalized.

On the pages that follow, we discuss the problems with the Draft in greater detail, and provide suggestions for how the deficiencies should be addressed in a revised draft EIS/EIR.

I. The Draft Fails to Adequately Analyze Impacts to Wildlife from Crop Idling Transfers, and Fails to Prescribe Required Mitigation

The National Environmental Policy Act (“NEPA”) has “twin aims. First, it places upon [a federal] agency the obligation to consider every significant aspect of the environmental impact of a proposed action. Second, it ensures that the agency will inform the public that it has indeed considered environmental concerns in its decisionmaking process.” *Baltimore Gas & Elec. Co. v. Natural Res. Def. Council, Inc.*, 462 U.S. 87, 97 (1983) (citation and internal quotation marks omitted). To achieve these goals, “[a]n EIS must include a comprehensive discussion of all substantial environmental impacts and inform the public of any reasonable alternatives which could avoid or minimize these adverse impacts.” *High Sierra Hikers Ass’n v. U.S. Dep’t of Interior*, 848 F. Supp. 2d 1036, 1048-1049 (N.D. Cal. 2012) (citing 40 C.F.R. § 1502.1). NEPA “emphasizes the importance of coherent and comprehensive up-front environmental analysis to ensure informed decision making to the end that the agency will not act on incomplete information, only to regret its decision after it is too late to correct.” *Blue Mts. Biodiversity Project v. Blackwood*, 161 F.3d 1208, 1216 (9th Cir. 1998) (quotation marks and citation omitted).

Similarly, the California Environmental Quality Act (“CEQA”) is intended to inform decision makers and the public about the potentially significant environmental effects of proposed projects. *See, e.g.*, 14 Cal. Code Regs. § 15002. To this end, an EIR “shall include a detailed statement setting forth . . . [a]ll significant effects on the environment of the proposed project” (Cal. Pub. Res. Code § 21100), and “must present information in such a manner that the foreseeable impacts of pursuing the project can actually be understood and weighed.” *Vineyard Area Citizens for Responsible Growth, Inc. v. City of Rancho Cordova*, 40 Cal. 4th 412, 450 (2007). If a significant effect on the environment is identified, an EIR is required to include provisions to avoid or mitigate the significant effect. Cal. Pub. Res. Code § 21081. Mitigation must be “fully enforceable through permit conditions, agreements, or other measures,” (*id.* § 21081.6 (b)) and there must be a reporting or monitoring program to ensure that the mitigation measures are implemented (*id.* § 21081.6 (a)). “The purpose of these requirements is to ensure that feasible mitigation measures will actually be implemented as a condition of development, and not merely adopted and then neglected or disregarded.” *Cal. Clean Energy Comm. v. City of Woodland*, 225 Cal. App. 4th 173, 189 (2014) (citation omitted).

*Comments on Long-Term Water Transfers Draft EIS/EIR
December 1, 2014*

A. The Environmental Commitments are Insufficient to Avoid Significant Impacts to Wildlife from Crop Idling Transfers and Additional Mitigation is Required

The proposed action includes several “environmental commitments,” which are intended to “avoid potential environmental impacts from water transfers.” Draft EIS/EIR at 2-29. These environmental commitments are critical to the Draft’s conclusion that the proposed action will not have a significant impact on special status plant and animal species. For example, the Draft concludes that significant impacts to the following species from crop idling transfers will be avoided, in whole or in part, by implementation of the environmental commitments: giant garter snake (*id.* at 3.8-70); Pacific pond turtle (*id.* at 3.8-71 to 3.8-72); greater sandhill crane (*id.* at 3.8-76); long-billed curlew (*id.* at 3.8-76); tricolored blackbird (*id.* at 3.8-77); white-faced ibis (*id.* at 3.8-78); purple martin (*id.* at 3.8-79); yellow-headed blackbird¹ (*id.* at 3.8-79 to 3.8-80); special status plant species (*id.* at 3.8-67); and special status bird species (*id.* at 3.8-74, 3.8-80).

However, as we explain below, these critically important environmental commitments are inadequate to avoid significant impacts to the species listed above, including the giant garter snake and sensitive birds. Because the impacts from crop idling transfers remain significant after implementation of the environmental commitments, CEQA requires that the action agencies identify additional mitigation measures that, if implemented, would reduce the impacts of the project to below the significance threshold. *See* Cal. Pub. Res. Code § 21081. In the sections that follow, we explain why the environmental commitments are inadequate to ameliorate significant impacts from crop idling transfers, and suggest additional mitigation measures that, if implemented, would help the agencies comply with legally-required mitigation obligations.

1. The Environmental Commitments Do Not Adequately Protect Giant Garter Snakes

The giant garter snake is listed as threatened under both the Federal Endangered Species Act and California Endangered Species Act. *See* Draft EIS/EIR at 3.8-23. The snake “primarily occurs in areas with dense networks of canals among rice agriculture and wetlands,” and has been observed within the Sacramento Valley portion of the Seller Service Area. *Id.* at 3.8-23 to 3.8-24. The Draft acknowledges that giant garter snakes may be substantially impacted by crop idling transfers. For example, it states that “[a]ny level of cropland idling/shifting would reduce the availability of stable wetland areas during a particular transfer year and may reduce suitable giant garter snake foraging habitat and increase the risk of predation on individual giant garter snakes.” *Id.* at 3.8-69. Yet the Draft concludes that the proposed action would have a less than significant impact on the giant garter snake “because a relatively small proportion (no more than 10.5 percent) of the rice acreage would be affected in any given year and the Environmental Commitments would avoid or reduce many of the potential impacts associated with this activity and the displacement of giant garter snake that could result.” *Id.* at 3.8-70.

¹ We assume that the discussion of the purple martin in the section titled “Yellow-Headed Blackbird” was an error, and that the Draft intended to refer to the yellow-headed blackbird.

Comments on Long-Term Water Transfers Draft EIS/EIR
December 1, 2014

The Draft's reliance on the purportedly small amount of rice acreage that would be idled under the proposed action is completely unsupported. The Draft provides no analysis of the population-level impact of a 10.5 percent reduction in habitat. Further, the long-term transfers will occur primarily in dry years, when rice acreage is already substantially reduced. *See id.* at 1-2 (project purpose and need indicating that transfers will occur during dry years); 3.8-69 (acknowledging that planted rice acreage is reduced by drought conditions). The California Rice Commission, for example, has reported that about 140,000 acres of rice, which amounts to 25 percent of last year's crop, went unplanted this year because of water shortfalls.² A 10.5 percent reduction in suitable habitat on top of already reduced rice acreage is substantial, and the Draft cannot assert that such a reduction is insignificant without biological analysis.

This leaves only the environmental commitments to support the no significant impact finding, and these too fail to ensure that significant impacts are avoided. It appears that the giant garter snake-focused environmental commitments were derived from previous Endangered Species Act biological opinions involving water transfers, including the Biological Opinion for Reclamation's 2010-2011 Water Transfer Program. *See* U.S. Fish and Wildlife Service ("FWS"), *Endangered Species Consultation on the Bureau of Reclamation's Proposed Central Valley Project Water Transfer Program for 2010 – 2011* (Mar. 2010) at 5-7 (attached as Exhibit A) (presenting "conservation measures" that are similar to Draft's environmental commitments); *see also* FWS, *Endangered Species Consultation on the Proposed 2009 Drought Water Bank for the State of California* (Apr. 2009) at 7-8 (attached as Exhibit B) (same). The biological opinions incorporated conservation measures that are similar to the Draft's environmental commitments into Reasonable and Prudent Measures, and concluded that compliance with those measures was "necessary and appropriate" to minimize the impact of take caused by the proposed crop idling transfers. Exh. A at 40; Exh. B at 38.

The California Department of Water Resources subsequently reaffirmed that "the conservation measures outlined in the USFWS biological opinion for Reclamation's 2010-2011 Water Transfer Program represent the most current and best scientific information on protective measures for the giant garter snake," and indicated that DWR "will require transfer proponents to incorporate in their transfer proposals those conservation measures from the biological opinion relevant to crop idling." California Department of Water Resources, *DRAFT Technical Information for Preparing Water Transfer Proposals* (Oct. 2013) at 22-23, available at http://www.water.ca.gov/watertransfers/docs/DTIWT_2014_Final_Draft.pdf.

The Draft's environmental commitments, however, are considerably less protective than the conservation measures that FWS and DWR have deemed to be necessary and appropriate, and reflective of the best scientific information available. First, the biological opinions required that the block size of idled rice parcels would be limited to 320 acres with no more than 20 percent of rice fields idled cumulatively (from all sources of fallowing) in each county. They further provided that the idled parcels would not be located on opposite sides of a canal or other waterway, and would not be immediately adjacent to another fallowed parcel. Exh. A at 5-6;

² *See, e.g.*, <http://www.capitalpress.com/California/20141021/rice-growers-wrap-up-drought-diminished-harvest>.

Comments on Long-Term Water Transfers Draft EIS/EIR
December 1, 2014

Exh. B at 7. Prior to the 2009 and 2010 biological opinions, FWS had concluded that a 160-acre limitation on the size of idled rice parcels was appropriate. See FWS, *Programmatic Biological Opinion on the Proposed Environmental Water Account Program* (Jan. 2004) at 18 (attached as Exhibit C). Defenders of Wildlife previously submitted comments indicating that increasing the parcel size from 160 to 320 acres would be harmful to giant garter snakes because the size of their home range is 40 and 90 acres, and forcing individuals to travel farther than this range may result in mortality. See *Comments on Addendum to the Environmental Water Account EIR/EIS* (Jan. 2009) (attached as Exhibit D). Yet the current Draft's environmental commitments do not include *any* limitation on the acreage of fallowed parcels, the cumulative percentage of rice fields in any county that can be idled, or the layout of idled parcels relative to each other and to particular habitat features.

5

Second, the biological opinions' conservation measures included a requirement that a field cannot be fallowed more than two irrigation seasons in a row. Exh. A at 6; Exh. B at 7. Again, this important conservation measure is entirely missing from the Draft's environmental commitments.

6

Third, the biological opinions required that the water seller maintain a depth of at least two feet of water in the major irrigation and drainage canals to provide a movement corridor for giant garter snakes. Exh. A at 6; Exh. B at 7. The Draft, on the other hand, provides that "[c]anal water depths should be similar to years when transfers do not occur or, where information on existing water depths is limited, at least two feet of water will be considered sufficient." Draft EIS/EIR at 2-29. The biological opinions' clear requirement of two feet of water is easier to monitor and enforce, and more protective of the giant garter snake.

7

Finally, the prior biological opinions all prohibited transfers from certain sensitive areas, including the Natomas Basin. Exh. A at 6; Exh. B at 7-8; Exh. C at 18. As discussed in Section I.A.4, below, the Draft does not make clear whether all transfers from areas with known priority giant garter snake populations will be prohibited. Such a prohibition is essential to protecting the threatened giant garter snake.

8

The Draft fails to justify its departure from these conservation practices that FWS and DWR have previously deemed to be the minimum requirements necessary and appropriate for protecting sensitive giant garter snake populations from crop idling transfers. Yet it inexplicably concludes that the environmental commitments would avoid or reduce to insignificant levels the proposed action's impacts on giant garter snakes. The Draft's departure from conservation measures that have been widely accepted as necessary to protect the giant garter snake undermines its no significant impact conclusion, and further mitigation is required. At a minimum, the environmental commitments must include all of the giant garter snake protections that were included in the 2009 and 2010 biological opinions. Further, we continue to believe that the 320-acre parcel-size limitation is not biologically justified and is insufficiently protective of the giant garter snake, and that a 160-acre limitation is warranted.

9

2. The Environmental Commitments Do Not Protect Birds from Impacts Caused by Crop Idling Transfers Involving Rice Fields

In addition to the giant garter snake, crop idling transfers involving seasonally flooded agricultural lands (i.e., rice) would affect waterfowl, shorebirds, waterbirds, and riparian songbird that rely on the fields for forage and nesting habitat. The Draft explains that “[s]easonally flooded agriculture, specifically rice fields, and its associated uplands, drainage ditches, irrigation canals, and dikes, provide potentially suitable habitat for . . . a variety of water birds including, but not limited to egrets, herons, ducks, and geese.” Draft EIS/EIR at 3.8-34. It also indicates that rice fields provide habitat and forage for special status bird species, including the greater sandhill crane, black tern, purple martin, tricolored blackbird, white-faced ibis, yellow-headed blackbird, and long-billed curlew. *Id.* at 3.8-25 to 3.8-30; 3.8-74. The Draft acknowledges that crop idling transfers will impact these species by reducing available forage and nesting habitat. *Id.* at 3.8-74 to 3.8-80.

These impacts are likely to be significant. The Draft indicates that the 51,473 acres of rice that could be idled in any year is equivalent to 10.5 percent of the average amount of land in rice production from 1992 to 2012. *Id.* at 3.8-69. The water transfers will occur in dry years, however, when planted rice acreage, other agricultural habitat, and wildlife refuge habitat are already greatly reduced. Thus, the crop idling transfers, in combination with other dry-year habitat reductions, will likely cause only a small fraction of the food and habitat necessary to sustain the special status bird species and other migratory birds to be available at critical times during the year.

The Draft concludes, however, that the proposed action would have a less than significant impact on special status bird species because there would be a less than significant impact on the habitats that support these species. *Id.* at 3.8-80. The impacts to seasonally flooded agricultural habitats, it concludes, would not be significant because of implementation of the environmental commitments. *Id.* at 3.8-65.³ There is only one environmental commitment, however, that is specifically designed to protect birds. It states that, “[i]n order to limit reduction in the amount of over-winter forage for migratory birds, including greater sandhill crane, cropland idling transfers will be minimized near known wintering areas in the Butte Sink.” *Id.* at 2-30.

Clearly, this one environmental commitment that is geographically limited to the Butte Sink is insufficient to mitigate impacts from the idling of rice fields throughout the Sellers’ service area because simply limiting habitat loss in one area does not ameliorate the impacts from habitat destruction elsewhere. Further, as discussed in Section I.A.4, the bird-focused commitment is so vague that it would provide little concrete protection for over-wintering birds in the Butte Sink.

³ As discussed *infra*, Section I.B, the Draft cannot rely on the availability of other suitable habitat to show that the proposed action will not have a significant impact because the Draft provides no analysis of the adequacy or availability of such habitat.

Comments on Long-Term Water Transfers Draft EIS/EIR
December 1, 2014

To the extent the Draft relies on the environmental commitments that are focused on protecting the giant garter snake, these commitments are inadequate to reduce impacts to bird species to insignificant levels. The giant garter snake commitments focus on habitat that is particularly important for that species, including major irrigation and drainage canals, smaller drains and conveyance infrastructure, and areas with known priority giant garter snake populations. While birds would receive some benefit from these protections, the commitments only reduce impacts to a very small percentage of the important bird habitat that will be lost as a result of the crop idling transfers.

Thus, the Draft's conclusion that impacts to special status bird species will be insignificant because of implementation of the environmental commitments does not withstand scrutiny. The one bird-focused commitment is inadequate, and the giant garter snake protections only address a very small percentage of the important bird habitat that will be impacted by crop idling transfers. Because the proposed action will result in significant impacts to special status bird species, and the environmental commitments are insufficient to ameliorate these impacts, additional mitigation is required.

First, we suggest including an environmental commitment that requires landowners on idled rice fields to cultivate or retain nonirrigated cover crops or natural vegetation to provide habitat and forage. Such a commitment would be in keeping with California Water Code section 1018, which provides that, "[w]hen agricultural lands are being idled in order to provide water for transfer . . . , landowners shall be encouraged to cultivate or retain nonirrigated cover crops or natural vegetation to provide waterfowl, upland game bird, and other wildlife habitat, provided that all other water transfer requirements are met." A report issued by California Waterfowl suggests that vetch and other cover crops can provide valuable habitat for birds, helping to mitigate impacts from idled rice fields. See California Waterfowl, *Rice-Cover Crop Rotation Pilot Project* (Feb. 2013) (attached as Exhibit E).

Second, we suggest including an environmental commitment that requires Reclamation to deliver a specific amount, such as 10 percent, of the water transferred in any crop idling transfer to south of Delta wildlife refuges that provide habitat for birds and other species that are impacted by the transfers. This environmental commitment would help to partially offset the habitat loss and refuge impacts caused by the proposed crop idling transfers.⁴

Third, we recommend including an environmental commitment that prohibits crop idling transfers on fields that are within 2 kilometers of wetlands and refuges, riparian corridors, and known Sandhill crane roost sites. This commitment is important because landscape context, particularly the amount and proximity of flooded wetland habitat, has been shown to be important to predicting shorebird abundance in wetland-agriculture mosaics.⁵ Landscape context

⁴ The Proposed Action's impacts on south of Delta refuges are discussed in Section III, below.

⁵ See Taft O. W, and Haig S. M. 2006. *Landscape context mediates influence of local food abundance on wetland use by wintering shorebirds in an agricultural valley*. Biological Conservation 128: 298–307; Elphick, C. S. 2008. *Landscape effects on waterbird densities in*

*Comments on Long-Term Water Transfers Draft EIS/EIR
December 1, 2014*

is also important for other waterbirds—the vast majority of heron and egret nesting colonies in the Sacramento Valley are in riparian stands along the major rivers and streams,⁶ and these birds must fly out to irrigated agricultural fields (mainly rice, also alfalfa, irrigated pasture, wetlands) to forage for themselves and to bring back food to nestlings. Additionally, wintering Sandhill cranes in the Central Valley forage mainly within 2 km of nighttime roost sites with suitable water depths and isolation from disturbance.⁷ Restricting crop idling transfers near wetlands and refuges, riparian corridors, and known Sandhill crane roost sites will help to minimize the proposed action’s impacts on important bird species.⁸

3. The Environmental Commitments Do Not Protect Birds from Impacts Caused by Crop Idling Transfers Involving Upland Crops

The proposed action also includes idling of up to 8,500 acres of upland crops, including idling of between 16 and 20 percent of existing corn acreage, depending on the county. Draft EIS/EIR at 3.8-63. In Sutter and Solano Counties, idling of upland crops could result in a 9 percent loss in residual feed. *Id.* According to the Draft, some upland crops, such as corn and wheat, are “highly beneficial to wildlife” (*id.* at 3.8-33), and several special status bird species, including greater sandhill cranes, long-billed curlews, and tricolored blackbirds rely on upland crops for forage and habitat. *Id.* at 3.8-25, 3.8-28, 3.8-29, 3.8-74. The Draft acknowledges that transfers involving the idling of upland crops could affect these species (*see, e.g., id.* at 3.8-74 to 3.8-77), and the impacts to these birds could be significant. As discussed above, the water transfers will occur in dry years, when other habitat is already substantially reduced. The food-supply reduction caused by the crop idling transfers, in combination with other reductions known to occur in dry years, could cause food shortages for special status bird species and other migratory birds that depend upon Central Valley habitats.

The Draft concludes, however, that “[b]ecause of the limited amount of upland crop acreage that would be idled under this alternative, and in conjunction with the environmental commitments described in Section 2.3.2.4, and because this is within the historic range of variation for the individual crops, cropland idling/shifting in the Seller Service Area is not

California rice fields: Taxonomic differences, scale-dependence, and conservation implications. Waterbirds 31:62–69.

⁶ Shuford, W. D. 2014. *Patterns of distribution and abundance of breeding colonial waterbirds in the interior of California, 2009–2012.* A report of Point Blue Conservation Science to California Department of Fish and Wildlife and U.S. Fish and Wildlife Service (Region 8). Available at www.fws.gov/mountain-prairie/species/birds/western_colonial.

⁷ Ivey, G. L., B. D. Dugger, C. P. Herziger, M. L. Casazza, and J. P. Fleskes. 2011. *Sandhill Crane Use of Agricultural Lands in the Sacramento–San Joaquin Delta.* Final Report Submitted to the California Bay-Delta Authority.

⁸ Implementation details for these and other proposed environmental commitments must be developed before they can be integrated into a final EIS/EIR. Allowing time for another round of comments on a revised draft document will help to ensure that all of the environmental commitments are clear and enforceable.

*Comments on Long-Term Water Transfers Draft EIS/EIR
December 1, 2014*

expected to significantly impact wildlife species dependent on upland cropland habitat.” *Id.* at 3.8-63 to 3.8-64.

This conclusion does not withstand scrutiny. First, the Draft provides no analysis to support the conclusion that the elimination of 8,500 acres of upland crop habitat will not have a significant impact, and as discussed above, the impact could be profound. Further, the assertion that the idling is not problematic because it is within the historic range of variation for individual crops misses the point—the crop idling transfers will occur during dry years, when planted acreage is already reduced. The idled acreage will be additive to the reductions that have historically occurred in dry years, and will likely be cumulatively substantial. As discussed in Section I.B, below, the Draft’s conclusory statements that impacts to birds will not be significant because there is sufficient alternative habitat and forage available are legally inadequate because they are unsupported by any analysis.

12

The Draft’s reliance on the environmental commitments is also misplaced. The one bird-focused commitment is geographically limited and unacceptably vague, and the protections for giant garter snakes are not relevant to upland crops, as giant garter snakes only exist in flooded agricultural habitats. The Draft’s conclusion that crop idling transfers involving upland crops won’t have significant impacts on special status bird species is unsupported, and in light of the evidence that impacts to these species will be significant, additional mitigation is required.

13

As discussed with respect to water transfers involving the idling of rice fields, we recommend including an environmental commitment that requires landowners with idled upland crops to cultivate or retain nonirrigated cover crops or natural vegetation in conformity with Water Code section 1018. We also recommend addition of an environmental commitment requiring Reclamation to deliver a specific percentage of the water made available from any crop idling transfer to south of Delta refuges. Additionally, we suggest including a commitment that prohibits crop idling transfers on fields that are within 2 kilometers of wetlands and refuges, riparian corridors, and known Sandhill crane roost sites.

We also recommend addition of a few environmental commitments that are specifically focused on upland crop habitat. Specifically, we suggest including a commitment that prohibits the idling of corn, winter wheat/triticale, or other grain crops that are particularly important to cranes and waterfowl. If water transfers involving the idling of these crops are not prohibited, we suggest including two additional commitments. First, the idling of corn, winter wheat/triticale, and other grain crops should be restricted to regions where there is a limited extent of such crops overall, and to areas with little or no current or historical use by greater sandhill cranes. Second, we suggest including an environmental commitment that limits transfers involving the idling of corn to areas where this crop is traditionally not flooded after harvest, as flooded corn supports a greater variety of bird species than does dry corn.⁹

14

⁹ Shuford, W. D., M. E. Reiter, K. M. Strum, C. J. Gregory, M. M. Gilbert, and C. M. Hickey. 2013. *The effects of crop treatments on migrating and wintering waterbirds at Staten Island, 2010–2012*. Final Report to The Nature Conservancy, 190 Cohasset Road, Suite 177, Chico, CA 95926.

4. The Environmental Commitments are Unacceptably Vague and No Enforcement Mechanism is Apparent

According to Reclamation's NEPA Handbook, "[e]nvironmental commitments are written statements of intent made by Reclamation to monitor and mitigate for potential adverse environmental impacts of an action." U.S. Bureau of Reclamation, *Reclamation's NEPA Handbook* (Feb. 2012) at 3-15, available at http://www.usbr.gov/nepa/docs/NEPA_Handbook2012.pdf. Reclamation is required to allocate funds necessary to carry out the commitments, monitor and evaluate the commitments' effectiveness, and document results. *Id.* at 3-16. Additionally, while implementation can be delegated to a third party as a permit condition, compliance with the environmental commitments remains Reclamation's responsibility. *Id.* The Handbook provides details regarding creation of an environmental commitments program, plan, and checklist to ensure the environmental commitments are appropriately implemented. *Id.* at 9-5 to 9-6.

Further, though they are integrated into description of the proposed action, the environmental commitments effectively operate as mitigation measures. CEQA requires that mitigation measures be "fully enforceable through permit conditions, agreements, or other measures." Cal. Pub. Res. Code § 21081.6(b). This requirement helps to ensure that "mitigation measures will actually be implemented . . . , and not merely adopted and then neglected or disregarded." *Cal. Clean Energy Comm*, 225 Cal. App. 4th at 189.

The Draft, however, does not appear to require that the environmental commitments be integrated as permit conditions, and does not make clear how Reclamation will enforce the commitments. The Draft merely provides that "Reclamation will have access to the land to verify how the water transfer is being made available and to verify that actions to protect the giant garter snake are being implemented," but does not explain how Reclamation will ensure compliance. Draft EIS/EIR at 2-29.

To adhere to Reclamation's NEPA Handbook and CEQA, and to ensure that the environmental commitments are enforced, we recommend that the environmental commitments be incorporated into the terms of contracts governing the water transfers. This approach has been used before—for example, the 2009 Biological Assessment for the Drought Water Bank provided that conservation measures for the giant garter snake "will be incorporated into contracts between DWR and the water seller." *2009 Drought Water Bank Biological Assessment* (attached as Exhibit F) at 11. The Biological Assessment elaborated that the contracts would include provisions allowing DWR to access the fallowed parcels to make sure the conservation measures were being implemented. *Id.* Incorporating similar terms into the contracts governing the long-term water transfers would help to ensure that the environmental commitments are more than empty promises.

Additionally, the environmental commitments are so vague that enforcement will be impossible, and any potential benefits are likely illusory. First, the bird-focused commitment provides that "cropland idling transfers will be minimized near known wintering areas in the

15

16

*Comments on Long-Term Water Transfers Draft EIS/EIR
December 1, 2014*

Butte Sink,” but it fails to define “minimized” and does not indicate how “known wintering areas” will be identified. Draft EIS/EIR at 2-30. Additionally, it does not specify what entity will oversee the proposed action to ensure that transfers near known wintering habitat are minimized. Unless additional clarity is provided, it will be impossible to effectively implement and enforce this commitment. 16

The commitments that focus on the giant garter snake are also so vague that implementation will be impossible. For example, one commitment provides that “[d]istricts proposing water transfers made available from idled rice fields will ensure that adequate water is available for priority habitat with a high likelihood of giant garter snake occurrence.” *Id.* The term “adequate water” is not defined, and the following commitment indicates that crop idling transfers *will* be permitted in priority habitat. *Id.* This suggests that a landowner could receive credit for transferring water out of priority habitat while still maintaining adequate water for giant garter snakes. This would likely be impossible because removing water from their habitat exposes giant garter snakes to displacement and the associated risks of predation and reduced food availability. *See id.* at 3.8-70. 17

Additionally, the environmental commitment regarding areas with known priority giant garter snake populations is ambiguous. It provides that:

Areas with known priority giant garter snake populations will not be permitted to participate in cropland idling/shifting transfers. Water sellers can request a case-by-case evaluation of whether a specific field would be precluded from participating in long-term water transfers. These areas include lands adjacent to naturalized lands and refuges and corridors between these areas, such as:

- Fields abutting or immediately adjacent to Little Butte Creek between Llano Seco and Upper Butte Basin Wildlife Area, Butte Creek between Upper Butte Basin and Gray Lodge Wildlife areas, Colusa Basin drainage canal between Delevan and Colusa National Wildlife Refuges, Gilsizer Slough, Colusa Drainage Canal, the land side of the Toe Drain along the Sutter Bypass, Willow Slough and Willow Slough Bypass in Yolo County, Hunters and Logan Creeks between Sacramento and Delevan National Wildlife Refuges; and
- Lands in the Natomas Basin. 18

Id. at 2-30. It is not clear from the text whether the areas that are specifically listed will be categorically excluded from participating in transfers, or whether landowners within these areas will be able to request a case-by-case determination regarding particular fields. As discussed above, if the latter is the intended interpretation, this is a major departure from the conservation measures included in recent giant garter snake biological opinions. Further, merely permitting landowners to request a parcel-specific evaluation is inadequate—what will be the consequence if a water seller chooses not to request such an evaluation?

Comments on Long-Term Water Transfers Draft EIS/EIR
December 1, 2014

Because the vague and unenforceable nature of the environmental commitments will render their benefits illusory, significant impacts will remain from crop idling transfers. The environmental commitments are legally inadequate and must be rewritten so that they are clear, protective, and enforceable, or alternative mitigation measures must be provided.

19

B. The Draft Makes Unsupported Assumptions Regarding the Availability of Alternative Habitat and Forage for Birds, Undermining its Conclusion that Impacts from Crop Idling Transfers Will Be Insignificant

To comply with CEQA, “[a] legally adequate EIR must produce information sufficient to permit a reasonable choice of alternatives so far as environmental aspects are concerned.” *Kings County Farm Bureau v. City of Hanford*, 221 Cal. App. 3d 692, 733 (1990) (quotation marks and citation omitted). “A conclusory statement unsupported by empirical or experimental data, scientific authorities, or explanatory information of any kind not only fails to crystallize issues but affords no basis for a comparison of the problems involved with the proposed project and the difficulties involved in the alternatives.” *Whitman v. Board of Supervisors*, 88 Cal. App. 3d 397, 411 (1979) (quotation marks and citations omitted). Similarly, one of NEPA’s primary purposes is “to guarantee relevant information is available to the public.” *N. Plains Res. Council, Inc. v. Surface Transp. Bd.*, 668 F.3d 1067, 1072 (9th Cir. 2011); *Natural Res. Def. Council v. U.S. Forest Serv.*, 421 F.3d 797, 811 (9th Cir. 2005) (“Where the information in the initial EIS was so incomplete or misleading that the decisionmaker and the public could not make an informed comparison of the alternatives, revision of an EIS may be necessary to provide a reasonable, good faith, and objective presentation of the subjects required by NEPA.” (quotation marks and citation omitted)).

20

The Draft’s analysis of impacts to birds from crop idling transfers falls far short of these standards. In particular, the Draft relies upon entirely unsubstantiated assertions regarding the availability of alternative forage and habitat to support its conclusion that the proposed action will have a less than significant impact on birds. For example, with respect to rice fallowing, it states that “[t]he decision to idle or shift a field would be made early in the year. So for species that migrate into the area seasonally (mainly birds), those arriving in the spring would not be impacted as they would select suitable habitat upon their arrival.” Draft EIS/EIR at 3.8-65. The Draft contains no analysis, however, to show that adequate suitable habitat would be available in all water year types. Similarly, for upland crops, it asserts that “[i]dling would reduce forage areas, but species would respond by looking for forage in other habitats. The bird species that would be potentially affected by idling of upland crops would be capable of dispersing to other areas or other non-idled parcels.” *Id.* at 3.8-63. Again, there is no analysis to show that adequate alternative food supplies exist. With respect to impacts to special status bird species, the Draft asserts that “[t]hese species are highly mobile and could easily relocate to other suitable habitats that would continue to exist in the surrounding areas.” *Id.* at 3.8-80; *see also id.* at 3.8-75, 3.8-78. The Draft is devoid of information regarding the availability of alternative suitable habitat in the surrounding areas.

The Draft’s assumption that adequate alternative forage and habitat exist ignores the context in which the transfers will occur. Importantly, the Draft fails to account for the fact that

21

*Comments on Long-Term Water Transfers Draft EIS/EIR
December 1, 2014*

water transfers will occur in dry years, when suitable habitat is least likely to be available. For example, during this drought year, 25 percent fewer acres of rice were planted in the Sacramento Valley than were planted the previous year. Additionally, water deliveries to federal, state, and privately managed wildlife refuges were substantially curtailed. The Draft also indicates that State Water Project crop idling transfers will likely occur at the same time as the long-term transfers, further reducing available habitat. *Id.* at 3.9-46 (“Cropland idling implemented under the SWP transfers could result in a maximum of 26,342 acres of idled rice land.”).

Moreover, existing evidence suggests that the Draft’s assumption that adequate alternative habitat will be available may be incorrect. For example, Ducks Unlimited used the bioenergetic model TRUOMET to evaluate the impact of California’s drought on waterfowl in the Central Valley. *See* Dr. Mark Petrie, Ducks Unlimited, Inc., *California’s Drought and Potential Impacts on Waterfowl* (May 2014) (attached as Exhibit G). The modeling showed that, under severe drought conditions, dabbling duck food supplies would be exhausted by early December, before bird numbers traditionally peak in the Valley, and dark geese and white geese food supplies would be exhausted by early February and late January, respectively. *Id.* at 10.

21

The impacts to birds from habitat reductions caused by the long-term transfers in dry years when habitat is already reduced could be profound. For example, a reduction of food availability would send birds back to their spring breeding grounds in poor condition, which would greatly reduce breeding success. In addition, the significant reduction in waterfowl habitat would cause overcrowding, which has in the past exacerbated outbreaks of avian diseases such as cholera and botulism. Such conditions could affect waterfowl populations for years to come.

Because the Draft’s conclusory statements regarding alternative bird habitat are “unsupported by empirical or experimental data, scientific authorities, or explanatory information of any kind,” they fail to comply with applicable law and additional analysis is required. *See Whitman*, 88 Cal. App. 3d at 411. We suggest that, at a minimum, a revised draft EIS/EIR should include bioenergetics modeling to assess the impact that crop idling transfers will have on available food supplies in various water year types and in light of other reductions in available habitat. TRUOMET modeling was conducted for the Bay Delta Conservation Plan (“BDCP”) environmental documents, and such modeling would be appropriate here. *See, e.g., BDCP Draft EIS/EIR at 12-729; 12-2559.*¹⁰

22

II. The Draft Improperly Fails to Analyze Impacts to Waterfowl and Shorebirds

Though the proposed action would likely have substantial impacts on waterfowl and shorebirds, the Draft entirely fails to discuss or analyze impacts to these species.¹¹ Such an

23

¹⁰ All chapters from the BDCP Draft EIS/EIR that are cited in this letter are available at <http://baydeltaconservationplan.com/PublicReview/PublicReviewDraftEIR-EIS.aspx>.

¹¹ The Draft does, however, acknowledge that waterfowl and shorebirds rely on seasonally flooded agricultural habitat. *See, e.g., Draft EIS/EIR at 3.8-14* (indicating that post-harvest winter flooding “provides habitat for waterfowl and other wildlife,” that invertebrates in flooded

*Comments on Long-Term Water Transfers Draft EIS/EIR
December 1, 2014*

analysis is required by CEQA, which provides that “[a]n EIR shall identify and focus on the significant environmental effects of the proposed project.” 14 Cal. Code Regs. § 15126.2.¹² “[S]ignificant effect on the environment,” in turn, “means a substantial, or potentially substantial, adverse change in any of the physical conditions within the area affected by the project including land, air, water, minerals, flora, fauna, ambient noise, and objects of historic or aesthetic significance.” *Id.* § 15382.

It is clear that crop idling transfers could lead to a substantial adverse change in the condition waterfowl and shorebirds within the project area. For example, modeling of population energy demand and population energy supply for dabbling ducks in the Central Valley shows that reduced winter-flooded rice acreage due to drought causes food demand to exceed supply. *California’s Drought and Potential Impacts on Waterfowl*, Exh. G. When further drought-related habitat reductions are taken into consideration, food demand far exceeds supply for dabbling ducks, and demand also outpaces supply for dark geese and white geese. *Id.* Water transfers involving the idling of seasonally flooded agricultural habitat will occur primarily in dry years when habitat is already reduced, and will further diminish the already-inadequate food supplies available to migratory waterfowl. Shorebirds, which also rely on seasonally flooded agricultural habitat, could be similarly impacted by crop idling transfers. Because impacts to waterfowl and shorebirds are an important part of the significant environmental effects of the proposed action, the Draft must include an analysis of impacts to these species.

The importance and feasibility of this analysis is underscored by the BDCP Draft EIS/EIR, which included substantial assessment of impacts to waterfowl and shorebirds. *See, e.g.*, BDCP Draft EIS/EIR at 12-729 to 12-745. The BDCP environmental document emphasized that “[m]anaged wetlands, tidal natural communities, and cultivated lands (including grain and hay crops, pasture, field crops, rice, and idle lands) provide freshwater nesting, feeding, and resting habitat for a large number of Pacific flyway waterfowl and shorebirds.” *Id.* at 12-729. It recognized that the proposed Plan would modify habitat in a manner that could affect these species, the included substantial analysis to understand the nature and extent of those impacts. *See, e.g., id.* at 12-729 to 12-745. The BDCP Draft EIS/EIR also acknowledged the Central Valley Joint Venture’s conservation goals, and analyzed impacts to waterfowl and shorebirds in light of the Joint Venture’s 2006 Implementation Plan. *Id.* at 12-729 to 12-730. In addition to qualitative discussions of impacts to waterfowl and shorebirds, the BDCP environmental document included analysis from the TRUOMET model to quantify the proposed action’s impacts on waterfowl. *See, e.g., id.* at 12-729.

fields “are particularly important to shorebirds,” and that “[r]ice fields provide pair, brood, and nesting habitat for birds such as mallard duck, northern pintail, and terns”).

¹² NEPA also requires an analysis of the proposed action’s effects on waterfowl and shorebirds, as these impacts are an important part of the environmental consequences of the proposed action. *See Nat’l Parks & Conservation Ass’n v. BLM*, 606 F.3d 1058, 1072 (9th Cir. 2010) (“Under NEPA, an EIS must contain a ‘reasonably thorough’ discussion of an action’s environmental consequences.” (citing *State of California v. Block*, 690 F.2d 753, 761 (9th Cir. 1982))).

*Comments on Long-Term Water Transfers Draft EIS/EIR
December 1, 2014*

The long-term water transfers would affect the same shorebirds and waterfowl as the proposed BDCP, and there is no valid reason for the Draft's complete exclusion of these species from its impacts analysis. We recommend that a revised draft EIS/EIR include both qualitative and quantitative analysis of the proposed action's impacts on waterfowl and shorebirds.

23

III. The Draft Improperly Ignores South of Delta State Wildlife Areas and Federal Wildlife Refuges

A. The Draft Fails to Analyze Potentially Significant Impacts to South of Delta Refuges

California law requires that an EIR "must include a description of the physical environmental conditions in the vicinity of the project." 14 Cal. Code Regs. § 15125(a). The CEQA Guidelines emphasize that "[k]nowledge of the regional setting is critical to the assessment of environmental impacts," and that "[s]pecial emphasis should be placed on environmental resources that are rare or unique to that region and would be affected by the project." *Id.* § 15125(c). A failure to accurately describe the environmental setting may render an EIR inadequate, *inter alia*, because important environmental impacts from the proposed action are likely to be omitted. *See San Joaquin Raptor/Wildlife Rescue Ctr. v. Cnty. of Stanislaus*, 27 Cal. App. 4th 713, 729 (1994) ("For the reasons set forth above, the description of the environmental setting of the project site and surrounding area is inaccurate, incomplete and misleading; it does not comply with State CEQA Guidelines section 15125. Without accurate and complete information pertaining to the setting of the project and surrounding uses, it cannot be found that the FEIR adequately investigated and discussed the environmental impacts of the . . . project."). Similarly NEPA requires a "full and fair discussion of significant environmental impacts," and a failure to discuss a significant impact can render an EIS legally inadequate. 40 C.F.R. § 1502.1.

24

Here, the Draft is fatally flawed because it fails to include important south of Delta State Wildlife Areas and Federal Wildlife Refuges in its description of the proposed action's environmental setting, and fails to analyze impacts to these important resources. *See* Draft EIS/EIR at 3.8-15 to 3.8-17. This omission is particularly odd because the Draft acknowledges that, within SLDMWA, "[w]ater for habitat management occurs on approximately 120,000 acres of refuge lands, which receive approximately 250,000 to 300,000 acre-feet (AF) per water year." *Id.* at ES-4.

Yet it is clear that the proposed action could have significant impacts on south of Delta refuges. First, the proposed action could result in increased avian overcrowding. Crop idling transfers will reduce available habitat and forage in the Sacramento Valley, placing additional pressure on the already-stressed south of Delta habitats. Overcrowding could reduce breeding success for important bird species, exacerbated outbreaks of diseases such as cholera and botulism, and could affect waterfowl populations for years to come.

Second, the Draft does not clearly discuss the order of priority for use of CVP conveyance facilities. If deliveries to the refuges are not appropriately prioritized, the refuges could be left without adequate water to support migratory bird populations. The Draft states that

25

*Comments on Long-Term Water Transfers Draft EIS/EIR
December 1, 2014*

“[t]ransfers that must be conveyed through the Delta are limited to periods when capacity at C.W. ‘Bill’ Jones Pumping Plant (Jones Pumping Plant) and Harvey O. Banks Pumping plant (Bank Pumping Plant) is available typically from July through September, *and only after Project needs are met.*” *Id.* at 2-18 (emphasis added). The Draft must clarify whether “Project needs” includes *all* deliveries to refuges that are required under the CVPIA. If Level 2 and Level 4 refuge deliveries are not considered “Project needs,” then the Draft must analyze how the proposed action could impact water delivers to the south of Delta refuges, and how any potentially reduced deliveries could impact migratory birds and other species that depend upon the refuges.

25

Third, the proposed action could increase the price of available water, making it impossible for Reclamation to purchase incremental Level 4 refuge supplies. A revised draft EIS/EIR should analyze how the proposed action will impact water prices, and whether price changes will affect Reclamation’s ability to provide full deliveries to the south of Delta refuges.

26

B. The Draft Should Include Transfers to South of Delta Refuges

Because it appears that impacts to south of Delta refuges could be significant, the Draft should include measures to mitigate these impacts. *See* Cal Pub Res. Code § 21081. A first step toward providing this mitigation would be to include transfers to south of Delta refuges in this environmental review. Reclamation needs flexibility to move available water quickly to protect these public trust resources, and including refuge transfers in this EIS/EIR would help to provide this flexibility. In dry years, north-to-south transfers can provide critically important water to south of Delta refuges. For example, this year, Reclamation transferred a portion of the permanent refuge supply that it purchased from the Anderson-Cottonwood Irrigation District from north of Delta refuges that could not physically receive the water, to the Kern National Wildlife Refuge, which is south of the Delta. Including such transfers in the proposed action would streamline approval and reduce transaction costs, allowing Reclamation to expeditiously provide water that is desperately needed for wetland habitat south of the Delta. We hope to see transfers to south of Delta refuges included in the proposed action in a revised draft EIS/EIR.

27

IV. The Draft Fails to Adequately Analyze Impacts to Fish and Wildlife from Groundwater Substitution and Reservoir Release Transfers

A. The Draft Uses Inappropriate Screening Thresholds to Avoid Analyzing Biological Impacts from Flow Reductions

1. The Draft Fails to Analyze Impacts to Fisheries Caused by Flow Reductions

28

The Draft’s analysis of impacts to fisheries from instream flow reductions caused by the proposed action is seriously deficient because the Draft applies an arbitrary, not biologically-based screening threshold to avoid analyzing potentially significant impacts. In particular, the Draft concludes that a reduction in instream flow would only be biologically significant if it involved both a 10 percent change in mean flow by water year type and a minimum change in flow of 1 cfs. Draft EIS/EIR at 3.7-20. These two thresholds were used as an initial screen, and

*Comments on Long-Term Water Transfers Draft EIS/EIR
December 1, 2014*

further analysis to assess biologically significant impacts to fisheries was only conducted if flow reductions were both greater than 10 percent and greater than 1 cfs. *Id.* at 3.7-21.

Based on application of these thresholds, the biological impacts from flow reductions in vast majority of waterways in the Sellers' service area were never assessed. For example, the Draft states:

Under the Proposed Action, mean monthly modeled flows would be reduced by less than ten percent on the Sacramento, Feather, Yuba, and American rivers. Based on the screening level criteria, these flow reductions are not considered substantial. Therefore, the effects of the Proposed Action on fisheries in these rivers would be less than significant.

Id. at 3.7-25. Because the Draft concluded that the impacts would be less significant based on the 10 percent significance threshold, impacts to fisheries on these critically important waterways were not analyzed. Similarly, the screening thresholds were applied to exclude the following waterways from any assessment of biological impacts caused by flow reductions: Deer Creek (in Tehama County), Antelope Creek, Paynes Creek, Elder Creek, Mill Creek (in Tehama County), Thomes Creek, Mill Creek (Thomes Creek tributary), Butte Creek, Auburn Ravine, Freshwater Creek, Colusa Basin Drain, Putah Creek, and Wilson Creek. *Id.*

The Draft does not, and cannot, adequately justify its use of these arbitrary thresholds. The document explains that “[t]he ten percent threshold was used to determine measurable flow changes based on several major legally certified environmental documents in the Central Valley related to fisheries,” including the Trinity River Mainstem Fishery Restoration Record of Decision (December 2000), the San Joaquin River Agreement Record of Decision (March 1999), the Freeport Regional Water Project Record of Decision (January 2005), and the Lower Yuba Accord EIR/EIS (October 2007). *Id.* at 3.7-20. Reliance on these old documents is misplaced because they do not reflect the best available scientific information, and because most of the documents were drafted for programs that *increased* flows. The Draft does not include any information regarding the biological significance of these thresholds, such as their relationship to water temperature, available spawning area, or other important factors.

Further, agencies have recently used a more conservative screening threshold to determine the potential significance of flow reductions. For example, the December 2013 Draft EIS/EIR for the proposed BDCP used a 5 percent screening threshold:

Physical modeling outputs each month and water year type were compared for between model scenarios at multiple locations to determine whether there were differences between scenarios at each location. A “difference” was defined as a >5% difference between the pair of model scenarios in at least one water year type in at least 1 month. If a difference was found at a location, subsequent biological modeling and analyses for fish species that occur in that location were conducted and reported for that location. If no differences were found,

28

29

*Comments on Long-Term Water Transfers Draft EIS/EIR
December 1, 2014*

subsequent biological modeling and analyses for fish species that occur in that location were deemed unnecessary and were not conducted.

BDCP Draft EIS/EIR at 11-202. The BDCP draft environmental document does not appear to use the additional 1 cfs threshold. Though the Draft and BDCP analyze impacts from flow reductions on the same rivers, the Draft does not attempt to explain why a less conservative threshold is appropriate for analysis of the proposed action's impacts to fish.

Because the Draft's reliance on the 10 percent and 1 cfs screening thresholds is inappropriate, and because impacts to special status fish species on the waterways that were eliminated based on application of the thresholds may be significant, further analysis is required. We recommend that a revised draft EIS/EIR analyze the significance of impacts based only on biological criteria, such as water temperature and changes to habitat quality. Alternatively, if a significance threshold for flow reductions is used, it should be at least as conservative as the 5 percent threshold used in the BDCP Draft EIS/EIR.

2. The Draft Fails to Analyze Impacts to Vegetation and Wildlife from Flow Reductions

The Draft uses the same screening thresholds from the fisheries chapter to determine whether flow reductions will have a significant impact on terrestrial species. Draft EIR/EIS at 3.8-38 ("If the flow reduction caused by implementing the transfer action would be less than one cubic feet per second (cfs) and less than ten percent change in mean flow by water year type, then no further analysis was required, because the effect was considered too small to have a substantial effect on terrestrial species."). The Draft justifies its use of these thresholds based on the same outdated documents it relied on in the fisheries section, even though the fisheries section indicates that those environmental reports were "related to fisheries." *Id.* at 3.8-39, 3.7-20. The use of these thresholds therefore appears to be even more arbitrary with respect to impacts to terrestrial species because the 10 percent threshold was derived from fisheries-related analysis.

Based on application of these thresholds, the vast majority of rivers and streams with special status terrestrial species were eliminated from consideration before biological impacts to those species could be analyzed. The following waterways were eliminated from further consideration based on the screening thresholds: Sacramento River, Feather River, Yuba River, American River, Deer Creek (in Tehama County), Antelope Creek, Paynes Creek, Seven Mile Creek, Elder Creek, Mill Creek (in Tehama County), Thomes Creek, Mill Creek (Thomes Creek tributary), Butte Creek, Auburn Ravine, Honcut Creek, Freshwater Creek, Colusa Basin Drain, Upper Sycamore Slough, Funks Creek, Putah Creek, Spring Valley Creek, Walker Creek, North Fork Walker Creek, Wilson Creek, Stone Corral Creek, Little Chico Creek, and the South Fork of Willow Creek. *Id.* at 3.8-49 to 3.8-50.

Because application of the screening threshold was inappropriate, and flow reductions from the proposed action could have a significant impact on special status terrestrial species that rely on the eliminated waterways, further analysis is required.

29

30

B. The Draft's Conclusions Regarding Impacts to Fish and Wildlife from Reduced Instream Flows on Specific Rivers are Unsupported

1. The Draft's Conclusions that Important Fish Species Will Not Be Impacted Lack Biological Support

For the rivers in which modeled flow reductions would exceed 10 percent and 1 cfs in any month, the Draft purports to conduct further biological analysis to determine whether the flow reduction would have a significant impact on special status fish species. Draft EIS/EIR at 3.7-21. The presented analysis, however, is entirely qualitative and extremely cursory. Though the lead agencies are familiar with a variety of modeling tools that could have helped to more fully understand the proposed action's impacts on fisheries, no modeling of biological impacts was conducted. The extensive modeling that was used in the BDCP Draft EIS/EIR suggests various tools that could have been used, including SALMOD, the Sacramento Ecological Flows Tool, and the Reclamation Temperature Model. While these and other available models have flaws, they provide important insights into how flow reductions will impact fisheries. The Draft's failure to conduct *any* modeling substantially undermines its conclusions that the proposed action will not result in significant impacts to special status fish species.

31

Further, the Draft's qualitative assessment of biological impacts from flow reductions is of such poor quality that it cannot be considered reliable. For example, for Stony Creek and Coon Creek, the Draft concludes that, because "significant" flow reductions—i.e., greater than 10 percent and 1 cfs—will happen infrequently, the impacts to special status fish species will be less than significant. Draft EIS/EIR at 3.7-28 to 3.7-29. The Draft does not explain, however, why the frequency of a low-flow event is dispositive as to biological impacts, and it is not at all clear that a single occurrence of low flows and high temperatures could not significantly impact sensitive fish populations. Additionally, with respect to Stony Creek, if a 5 percent significance threshold was used instead of a 10 percent threshold, "significant" flow reductions would occur in many more months. *Id.* at 3.8-56 to 3.8-57. For Coon Creek, the Draft doesn't even mention which species could be impacted. *Id.* at 3.7-29.

32

With respect to Little Chico Creek, the Draft appears to conclude that, because the Creek already suffers from low flows, additional flow reductions will not be problematic. *Id.* at 3.7-29. The Draft cannot simply write off the biological impacts from an increased frequency of low flow events without providing any analysis of effects on temperature, habitat suitability and availability, and other important factors.

33

On Cache Creek, the Draft concludes that there will be no impact to Fall-run Chinook salmon because connectivity for migration only exists in wet years, and there are no significant instream flow reductions in wet years. *Id.* at 3.7-28. The significance determination is based on the unsupported 10 percent figure, however, and use of a more conservative threshold would show that a significant flow reduction would occur in October in wet years. *See id.* at 3.8-55.

34

*Comments on Long-Term Water Transfers Draft EIS/EIR
December 1, 2014*

The Draft also appears to erroneously exclude waterways that may contain special status fish species from further biological review. The Draft states that “[n]o field sampling information is available regarding the presence of special-status fish species in the following waterways: Seven Mile Creek, Elder Creek, Spring Valley Creek, North Fork Walker Creek, and Wilson Creek.” *Id.* at 3.7-9. It elaborates that, “[w]ithout further information, it was assumed that these streams could support special-status fish species and, therefore, further biological analyses were conducted in these waterways.” *Id.* In the following paragraph, however, the Draft states that field sampling data and reports indicate that special status fish species are not present in Seven Mile Creek, Spring Valley Creek, North Fork Walker Creek, and Wilson Creek, and accordingly that no further biological analysis was conducted for these waterways. *Id.* A revised draft EIS/EIR should clarify whether there is field sampling information available for these Creeks, and should conduct biological analysis if information regarding the presence of special status fish species is not available.

35

The impacts of the proposed action on fisheries remain unclear because the Draft uses inappropriate screening thresholds, fails to model biological impacts, and includes logically unsound qualitative assessments of biological impacts from admittedly significant flow reductions. To comply with CEQA and NEPA’s legal requirements that an EIS/EIR provide the public with sufficient information to understand the environmental impacts of a proposed project and meaningfully compare alternatives, substantially more analysis is required, including modeling to understand the biological implications of flow reductions.

36

2. The Draft’s Conclusions that Vegetation and Wildlife Will Not Be Impacted Lack Biological Support

Similarly, for terrestrial species, the Draft’s analysis of biological impacts on the few waterways that it analyzes after application of the screening thresholds is unacceptably cursory. For example, for Coon Creek, the Draft concludes that impacts to terrestrial species will not be significant because substantial flow reductions will occur infrequently. Draft EIS/EIR at 3.8-59. The Draft does not present any biological information or analysis to show that the frequency of low-flow events determines the impacts of those events on sensitive species.

37

With respect to Little Chico Creek and Bear River, the Draft seems to conclude that flow reductions will have a less than significant impact on terrestrial species because the flow reductions are likely to occur when water levels are already low. *Id.* at 3.8-59 to 3.8-61. These conclusions are unsupported by data or analysis. Further, it seems that flow reductions could have a particularly profound impact during dry years or periods when streamflow is already low, as every drop of available water would be critical for riparian ecosystems. Further analysis that actually describes the anticipated impacts to the terrestrial species that rely on these waterways is required.

38

Finally, for Cache Creek and Stony Creek, the Draft concludes that flow reductions could have a significant impact on the riparian natural communities associated with these streams. *Id.* at 3.8-52 to 3.8-53, 3.8-58. These impacts would be reduced to less-than-significant levels, the Draft concludes, through implementation of the groundwater mitigation measure. *Id.* As

39

Comments on Long-Term Water Transfers Draft EIS/EIR
December 1, 2014

discussed in the next section, however, the groundwater mitigation measure is insufficiently protective, and significant impacts will remain after its implementation.

39

C. The Mitigation Measure for Potentially Significant Impacts from Groundwater Substitution Transfers is Inadequate

In several instances, the Draft relies on Mitigation Measure GW-1 (*see* Draft EIS/EIR at 3.3-88 to 3.3-91) to conclude that otherwise significant impacts will be reduced to less-than-significant levels. For example, it relies on the groundwater mitigation measure to avoid significant impact to natural communities along Cache Creek and Stony Creek (*id.* at 3.8-52 to 3.8-53, 3.8-58), and to ameliorate potentially significant impacts to fish and terrestrial species associated with small streams for which no historical flow data are available (*id.* at 3.7-26, 3.8-51). Similarly, the Draft concludes that the groundwater mitigation measure would help to eliminate the possibility of cumulatively significant impacts to fisheries. *Id.* at 3.7-56. With respect to impacts to vegetation and wildlife, the Draft generally concludes that the “Environmental Commitments described in Section 2.3.2.4 and Mitigation Measure GW-1 described in Section 3.3 would eliminate or reduce the potentially substantial effects of water transfer actions.” *Id.* at 3.8-90.

40

Mitigation Measure GW-1 requires potential sellers to comply with a specific set of monitoring provisions, and to create and implement a mitigation plan. *Id.* at 3.3-88 to 3.3-91. “The purpose of Mitigation Measure GW-1 is to monitor groundwater levels during transfers to avoid potential effects. If any effects occur despite the monitoring efforts, the mitigation plan will describe how to address those effects.” *Id.* at 3.3-91. The monitoring requirements include measurement of well discharge rates and volumes, groundwater-level measurements, and assessments of land subsidence. *Id.* at 3.3-88 to 3.3-89. The Draft requires that a mitigation plan include “[d]evelopment of mitigation options,” and suggests particular actions, including curtailment of pumping, reimbursement for increased pumping costs, and reimbursement for expenses caused by infrastructure damage from land subsidence. *Id.* at 3.3-90 to 3.3-91.

There are no specific actions, however, to address significant impacts to fisheries and riparian communities that could result from streamflow depletions associated with groundwater substitution transfers. This is problematic because, as discussed above, the Draft recognizes that groundwater substitution transfers could cause significant impacts to fish and terrestrial species, and relies on Mitigation Measure GW-1 to reduce these impacts to less-than-significant levels. By relying on not-yet-created plans to mitigate impacts to fish and wildlife, without demonstrating how these impacts can be mitigated, the Draft violates CEQA’s prohibition on deferred mitigation. *See, e.g., City of Long Beach v. Los Angeles Unified Sch. Dist.*, 176 Cal. App. 4th 889, 915-16 (2009) (“Impermissible deferral of mitigation measures occurs when an EIR puts off analysis or orders a report without either setting standards or demonstrating how the impact can be mitigated in the manner described in the EIR.”).¹³

41

¹³ The environmental commitment focused on groundwater substitution transfers does not fix this problem because it merely requires that mitigation plans address impacts to water resources

Comments on Long-Term Water Transfers Draft EIS/EIR
 December 1, 2014

To remedy this problem, a revised draft EIS/EIR should include particular actions that sellers can take to mitigate significant impacts to fisheries, vegetation, and wildlife caused by groundwater substitution transfers. For example, the revised draft could include a mitigation action requiring a seller who is responsible for a flow reduction that significantly impacts fish and wildlife to curtail pumping and dedicate a portion of his surface water supply to flows for fish and wildlife until the waterway is no longer impacted by the seller's transfer-related groundwater pumping.

41

V. The Draft Fails to Analyze Impacts to Wildlife from Increased Irrigation of Drainage-Impaired Lands in the Buyers' Service Area

The Draft also fails to adequately analyze impacts to water quality and wildlife that could occur in the Buyers' service area as a result of increased irrigation of drainage-impaired lands. It is well known that substantial acreage within SLDMWA is compromised by the accumulation of selenium-laden drainage water in the shallow groundwater table. For example, as of 2006, there were approximately 298,000 acres of drainage-impaired lands within Westlands Water District. U.S. Bureau of Reclamation, *San Luis Drainage Feature Re-evaluation Final Environmental Impact Statement* (May 2006) at ES-15, available at http://www.usbr.gov/mp/nepa/nepa_projdetails.cfm?Project_ID=61. The Draft acknowledges that increased irrigation of lands with contaminated drainage water could impact surface waters in the region because "increased irrigation could cause water to accumulate in the shallow root zone and could leach pollutants into the groundwater and potentially drain into the neighboring surface water bodies." Draft EIS/EIR at 3.2-41. As is clear from the experience at Kesterson Reservoir, drainage-water discharges to surface waters can have profound impacts on wildlife, including sensitive migratory birds.

42

The Draft, however, concludes that increased irrigation of drainage-impaired lands will not be a problem because the proposed action would be implemented in dry years, so "most water would be applied to permanent crops or crops planted on prime or important farmlands," and "farmers would continue to leave marginal land and drainage impaired lands out of production and use water provided by the Proposed Action for more productive lands." *Id.* But this statement is contradicted elsewhere in the Draft. For example, the chapter on agricultural land use states that the proposed action would "increase water supplies and potentially allow growers to place previously idled land into production." *Id.* at 3.9-48. Additionally, the Draft indicates that the Exchange Contractors could sell up to 150,000 acre feet, and that "both projects could sell their water to the same buyers." *Id.* at 3.8-93. It clearly remains possible that the proposed action would result in increased irrigation of drainage-impaired lands.

The Draft also suggests that any drainage created by the proposed action would not be problematic "given drainage management, water conservation actions and existing regulatory compliance efforts already implemented in that area." *Id.* at 3.2-41. Yet the status of drainage

43

needed for special status species protection, but does not provide any guidance as to how the impacts can be mitigated. *See* Draft EIS/EIR at 2-29.

*Comments on Long-Term Water Transfers Draft EIS/EIR
December 1, 2014*

management in the region remains unclear. Reclamation is in the process of finalizing a settlement agreement with Westlands that would shift responsibility for providing drainage services from the federal government to the district. See *Principles of Agreement for a Proposed Settlement Between the United States and Westlands Water District Regarding Drainage* (Dec. 2013) (attached as Exh. H). Though the draft settlement agreement has not been made public, the attached Principles of Agreement suggest that that the deal may not include important safeguards such as performance standards, monitoring requirements, federal oversight, and enforcement mechanisms to ensure that any drainage-water discharges are properly managed. Further, the Principles of Agreement indicate that the settlement will only require Westlands to retire 100,000 acres, leaving almost 200,000 acres of drainage-impaired land within the district eligible for irrigation. In light of the major deficiencies in the pending settlement, the Draft cannot rely on “existing regulatory compliance efforts” to avoid addressing the drainage-related impacts that the proposed action could cause.

Because the proposed action could lead to increased irrigation of drainage impaired lands in Westlands and other districts, causing potential impacts to birds and other wildlife, and because it is uncertain whether there will be an effective drainage management plan in place, a revised draft EIS/EIR should include a quantitative analysis of potential environmental impacts from this increased irrigation, including water quality impacts to surface waters in the Buyers’ service area, as well as an assessment of potential impacts to migratory birds and other wildlife.

VI. The Draft Fails to Analyze an Adequate Range of Alternatives

Both CEQA and NEPA require consideration of a reasonable range of alternative actions that might achieve similar goals with less environmental impact. Cal. Pub. Res. Code §§ 21002, 21061, 21100; 14 Cal. Code Regs. § 15126.6; 42 U.S.C. § 4332; 40 C.F.R. §§ 1502.14, 1508.25(b). “The existence of a viable but unexamined alternative renders an environmental impact statement inadequate.” *Natural Res. Def. Council*, 421 F.3d at 813 (quotation marks and citation omitted). Further, CEQA is designed to prevent public agencies from approving projects if feasible alternatives or mitigation measures would substantially lessen the significant environmental effects. Cal. Pub. Res. Code § 21002.

Here, the Draft has failed to analyze an alternative that could achieve the project purpose with a less substantial environmental impact. The Draft analyzes four alternatives: (1) no action/no project; (2) full range of transfers (proposed action); (3) no cropland modifications; and (4) no groundwater substitution. Draft EIS/EIR at 2-6. While the two action alternatives other than the proposed alternative restrict the available methods of transfer, the Draft does not consider any action alternative that restricts the *quantity* of water that may be transferred. Cropland modification transfers and groundwater substitution transfers affect environmental resources differently, and the alternatives that exclude one or the other method reduce some, but not all, impacts associated with the proposed action. An alternative that reduces the amount of water that could be transferred, for example to 50 percent of the amount included in the proposed action, for both cropland modification transfers and groundwater substitution transfers would reduce almost all of the environmental impacts caused by the proposed action to some extent. Because such an alternative would still meet the project’s objectives, and would substantially

43

44

reduce environmental impacts, it should be included and fully analyzed as an alternative in a revised draft EIS/EIR.

44

VII. The Draft Fails to Account for Climate Change Impacts

It is well accepted that changes to California's temperature and precipitation regime will occur in the future, and these changes will affect nearly all aspects of the CVP system. Further, the Draft acknowledges that, among other impacts, "[c]limate change will continue to affect natural ecosystems, including changes to biodiversity, location of species and the capacity of ecosystems to moderate the consequences of climate disturbances such as droughts. In particular, species and habitats that are already facing challenges will be the most impacted by climate change." Draft EIS/EIR at 3.6-13 (citations omitted).

Though it recognizes that climate change impacts are occurring now, the Draft concludes that climate change will not significantly impact the proposed action because of the action's ten-year timeframe: "Because of the short-term duration of the Proposed Action (10 years), any effects of climate change on this alternative are expected to be minimal. Impacts to the Proposed Action from climate change would be less than significant." *Id.* at 3.6-21 to 3.6-22. Similarly, in its analysis of impacts to fisheries, the Draft concludes that climate change will not alter conditions in reservoirs, rivers and creeks, or the Delta because there will be limited climate change predicted over the project's ten year duration. *Id.* at 3.7-23 to 3.7-24. Beyond these conclusory statements, the Draft includes no modeling or analysis to show the proposed action's impacts in light of expected climate change.

45

The Draft's approach to climate change is a substantial departure from recently produced environmental documents in which climate change is incorporated into the operational modeling for the project. For example, Reclamation incorporated climate change into the modeling and assessment of environmental impacts for the BDCP's draft environmental documents. *See, e.g.*, BDCP Draft EIS/EIR at 4-6, 5-47 to 5-49, and Appendix 3E. In the BDCP Draft EIS/EIR, the "CALSIM model was used to simulate how projected changes in runoff (i.e., reservoir inflows) for two future climate periods, 2025 and 2060 conditions, would affect existing reservoir operations and Delta inflows in the project area." *Id.* at Appendix 29B-1. Importantly, the above quote reflects that the BDCP Draft EIS/EIR included climate changes impacts in its operational model for 2025—only one year after the time period covered by the proposed action. The proposed BDCP and the proposed action have overlapping action areas and operational considerations, and BDCP's modeling of climate change impacts in 2025 undermines the Draft's position that climate change impacts within a ten year time frame will be inconsequential.

Because the Draft's analysis and operational modeling does not reflect likely operations in the future with climate change, the Draft's assessment of potential environmental impacts fails to accurately assess the impacts of the proposed action in light of climate change. This approach is not consistent with CEQA or NEPA, and the operational modeling must be revised to incorporate climate change in order to accurately assess potential environmental impacts.

*Comments on Long-Term Water Transfers Draft EIS/EIR
December 1, 2014*

VIII. The Draft Fails to Adequately Assess Cumulative Impacts

The Draft fails to adequately consider cumulative impacts because it fails to include an assessment of potentially cumulative projects. Initial comments on the proposed action that the Glenn-Colusa Irrigation District (“GCID”) submitted to Reclamation on October 14, 2014 illustrate the problem. GCID’s letter describes its Groundwater Supplemental Supply Program, through which it is proposing to install and operate five new groundwater production wells and operate an additional five existing wells for use within GCID during dry and critically dry water years. The letter indicates that the wells would have a production capacity of approximately 2,500 gallons per minute, and would operate during dry and critically dry water years for a cumulative total annual pumping volume of up to 28,500 acre feet. The letter indicates that pumping under the Groundwater Supplemental Supply Program would likely occur in the same years as the long-term transfers that the Draft analyzes. Yet the Draft does not include GCID’s Program in its analysis of cumulative impacts to groundwater resources. *See* Draft EIS/EIR at 3.3-91 to 3.3-92. The cumulative impacts caused by groundwater substitution transfers covered by the proposed action and groundwater pumping under GCID’s new program could be significant, and further analysis is required. More generally, GCID’s letter suggests that the Draft’s authors did not adequately survey the proposed action’s potential sellers to understand their future operations, raising questions about other likely projects that have been excluded from the Draft’s cumulative impacts analysis.

46

Thank you for consideration of our views. Please feel free to contact me at your convenience if you have any questions or concerns.

Sincerely,



Rachel Zwillinger
Water Policy Advisor
Defenders of Wildlife
rzwillinger@defenders.org
415-686-2233

Buckman, Carolyn

From: Hubbard, Bradley <bhubbard@usbr.gov>
Sent: Monday, December 01, 2014 8:20 PM
To: Frances Mizuno; Buckman, Carolyn; Veronese, Gina
Subject: Fwd: Long-Term Water Transfers Draft EIR/EIS

Email comment.

----- Forwarded message -----

From: **Joni Clark Stellar** <clarkstellar@gmail.com>
Date: Mon, Dec 1, 2014 at 5:53 PM
Subject: Long-Term Water Transfers Draft EIR/EIS
To: bhubbard@usbr.gov

Mr. Brad Hubbard
 Long-Term Water Transfers Draft EIR/EIS
 2800 Cottage Way, MP-410
 Sacramento, CA 95285

Dear Mr. Hubbard:

A profound need exists to reconcile ALL proposed water transfer policies with California's new Groundwater legislation, existing over-commitment of surface waters, and the current massive, long-term drought conditions. Groundwater levels are in severe decline in Northern California – and proposed transfers will only make this situation worse. Lack of snow and rain is limiting recharge of aquifers. Insufficient surface flows into San Francisco Bay and Delta are negatively impacting this most important estuary to fisheries on the West Coast. There simply isn't enough water to go around.

Many people living in Northern CA express deep and valid concerns about their wells going dry. People need water for personal needs, farming, fishing, recreation, and more. Yet, any hope for a "sustainable relationship" between the North State residents and our water supplies is evaporated by plans to transfer so much water south.

Governmental agencies should use the best, most current and pertinent data to make analyses of water systems so as to make good predictions and plans. However, the baseline data your agency uses to plan transfers of water out of Northern California includes only the years 1973-2003. As the current extensive, severe drought continues, more current data must be incorporated to make appropriate predictions and plans. Careful conservation and wise use of precious water can be better planned using more accurate data.

Please help everyone in California confront the realities of the current drought and on-going climate change. Conserving water should be the major focus of government agencies and corporations, as well as residents and small farmers. For example, directing farmers to plant crops that use far less water than many current agribusinesses 'need,' and to use drip irrigation instead of 'flood' irrigation methods still in common use. Residents and municipalities should greatly reduce turf grass and other water-intensive landscaping, replacing it with less water-thirsty plantings.

We cannot afford to have Northern California streams, lakes, and groundwater drained just to transfer water to reservoirs and tunnels designed to help Southern California water districts and big agricultural corporations make profits and maintain their status quo. The costs to our communities and environment (including forests, animals, fishes), and taxes, are simply too high. We do not want or need a "Cadillac Desert" in California.

Sincerely,
Joni C. Stellar
Butte County resident dependent upon groundwater

--
Joni Stellar
Treasurer
Frack-Free Butte County

--
Thanks,

Brad

Buckman, Carolyn

From: Hubbard, Bradley <bhubbard@usbr.gov>
Sent: Monday, December 01, 2014 9:04 AM
To: Frances Mizuno; Buckman, Carolyn; Veronese, Gina
Subject: Fwd: Long-Term Water Transfers Draft EIR/EIS

Comment email.

----- Forwarded message -----

From: <g-marvin@comcast.net>
Date: Mon, Dec 1, 2014 at 7:13 AM
Subject: Long-Term Water Transfers Draft EIR/EIS
To: bhubbard@usbr.gov
Cc: "Casey, Louise" <YAHInews@comcast.net>, "Fritsch, Sharon" <safritsch@comcast.net>, "Garcia, Celeste" <celesterdh@mynvw.com>, "Garcia, Dave" <rangerdave@mynvw.com>, "Heath, Laurel" <laur3290@gmail.com>, "Hollister, John" <hubhollister@yahoo.com>, "Krause, Paul" <paul@paulkrause.com>, "Lydon, Gerda&" <plydon2948@aol.com>, "Marvin, Grace" <g-marvin@comcast.net>, "McKinney, David" <daviddryfly@comcast.net>, "Mendoza, Alan" <ajmendoza@prodigy.net>, "Welch, Suzette" <booksontape@rocketmail.com>

From: 1621 N. Cherry Street
Chico, CA 95926-3141
November 30, 2014

To: Mr. Brad Hubbard
Long-Term Water Transfers Draft EIR/EIS
2800 Cottage Way, MP-410
Sacramento, CA 95285

Dear Mr. Hubbard:

As Conservation Chair of the Yahi Group of the Sierra Club, I attended your "Public Meeting" on 10/21/2014 concerning Long-Term Water Transfers Draft EIR/EIS.

In light of my concerns about the talk, I asked questions at the meeting linking the need to connect the spirit behind the Groundwater legislation adopted by Governor Brown for our state and the transfer policies. Subsequently, I reviewed the the Sierra Club water policy (developed by the Club's California Nevada Regional Conservation Policies or CNRCC in 1993 and amended in 2004 and 2009). There I saw how the transfer policy you presented violated the spirit of the club's water policies that are devoted to careful preservation and wise use of our natural resources. Here are some examples:

The CNRCC states one goal is to "preserve and restore naturally functioning biodiverse, and productive aquatic ecosystems throughout California." In my opinion, to do so requires that agencies use pertinent data to make analyses of water systems so as to make better predictions. But the baseline data your agency uses to plan transfers of water out of the north state cover the years 1973-

1
2

2003. Since we are now seeing uniquely dry conditions now and well into the future, why not use more current data to make predictions? “Careful preservation and wise use” of our water can be better planned using more accurate data.

2

Another process that is violated in the transfer policies is the following:“Develop a sustainable relationship between people and the aquatic environment to meet the needs of each.” As we heard at the 10/21/14 meeting a large number of people expressed deep concerns about their wells being either completely dry or nearly so. People need this water for personal needs, farming, fishing, recreation, and more. Yet, any hope for a “sustainable relationship” between many of us in the north state and our water supplies was evaporated by the plans to transfer water south.

3

Furthermore, the Water Ethic” spelled out in the CNRCC policy is that individuals and organizations should “utilize water conserving practices in agricultural and urban areas.” But no mention was made of any kind of effort to direct farmers to plant crops that use far less water than many current agribusinesses 'need.'

4

Finally, the Sierra Club is focused on the environment--which we are supposed to enjoy, preserve, and protect. Many other aspects of the CNRCC policy are violated with the water transfer policy, but I ask you to pay special attention to this one, since you are part of an institution that is capable of making such changes: “Adapt water use, pollution control, land use, and other social and economic patterns to reduce and avoid conflicts with environmental needs.” Please help us in the north state in confronting the current drought and on-going climate change. We cannot afford to have our streams, lakes, groundwater, and rivers drained in order to transfer water to reservoirs and tunnels designed to help southern water districts and agricultural corporations make profits that cost our environment (including trees, animals, fish) so much. We do not want another “cadillac desert” in California.

5

Sincerely,
Grace M. Marvin
Conservation Chair
Sierra Club, Yahi Group

--
Thanks,

Brad



Sacramento Office
555 Capitol Mall, Suite 1290
Sacramento, CA 95814

Tel (916) 449-2850
Fax (916) 448-3469

nature.org

December 1, 2014

Brad Hubbard
U.S. Bureau of Reclamation
2800 Cottage Way, MP-410
Sacramento, CA 95825

Re: Comments on the Long-Term Water Transfers Draft Environmental Impact Statement /
Environmental Impact Report (Draft EIS/EIR) – The Nature Conservancy

Dear Mr. Hubbard,

As both a conservation organization and land owner in the Delta and Sacramento Valley, The Nature Conservancy (TNC) has been engaged in the Central Valley and Delta for many years to advance the recovery of endangered species, restore and preserve multiple types of habitat, and seek to apply sound science and practical solutions that work for nature and people.

Of particular interest to the Conservancy is the importance of achieving overall sustainable water management practices in California; both for the benefit of people and natural systems. The California Water Action Plan recognizes that this includes imperative actions such as improving groundwater management, better managing our surface flows, restoring wetlands and watersheds, and facilitating water transfers. The challenge facing California’s water managers, including the federal agencies and water districts who are the principal entities that will participate in—and benefit from—this Long-Term Water Transfer program, is to implement water transfer programs in a manner that is clear and transparent, based on sound science, and which minimizes impacts by design, especially in areas of origin.

We agree that water transfers are an important tool for overall sustainable water management when properly designed and implemented with appropriate mitigation; however, we are concerned about the potential impacts that could occur with implementation of the Proposed Action, and we are not confident that these impacts have been addressed through the mitigation measures and environmental commitments outlined in the Draft EIS/EIR.

In particular, The Nature Conservancy is concerned about the impacts to fish and wildlife that could result from surface water and groundwater transfers of the magnitude envisioned in the Draft EIS/EIR, especially related to sustainable groundwater and surface water management. We are also concerned that the fallowing described in the Proposed Action may impact wildlife-friendly farming necessary for Pacific Flyway habitat for migratory birds. For example, water transfers are likely to result in the idling of riceland and other compatible agricultural land in the Sacramento Valley, where now the water applied to many of these crops serves multiple purposes and represents a decade of cooperation and innovation between our organization, our partners, and the landowners with whom we work. As we discuss below, more robust environmental commitments are critical to address the potentially significant impacts of the

1

Proposed Action, and also present an opportunity to demonstrate true sustainable water management that works for both people and natural systems. Additionally, the Draft EIS/EIR must demonstrate a clear linkage and rationale between the environmental commitment or measure and what impact will be avoided or mitigated, and use best available science.

1

The attachment elaborates on the following summary of our comments, and provides recommendations that can serve as a starting point to develop more robust environmental commitments for the Proposed Action.

1. **Environmental commitments are inadequate to avoid or mitigate impacts, and must give environmental consequences a “hard look.”**
2. **Environmental commitments to address impacts to migratory and resident waterbirds must be expanded based on best available science and consider cumulative impacts from all sources of habitat reduction in the Central Valley.**
3. **Potential significant impact on Reclamation’s ability to deliver water to refuges should be analyzed and lessened through environmental commitments.**
4. **Impacts from groundwater substitution transfers should be accurately simulated and more clearly illustrated. The Draft EIS/EIR should account for compounding impacts of multiple or repeated groundwater substitution transfers over time, and water supply and environmental impacts should be mitigated until recovery is achieved.**
5. **Environmental commitments should more fully develop a suite of additional actions that ultimately result in additional benefits for nature and provide incentives for those actions such as a transfer priority system to drive their implementation and adoption.**

We urge you to strongly consider the additional our comments and the environmental commitments and mitigation measures we suggest, and would welcome the opportunity for additional dialogue.

Sincerely,

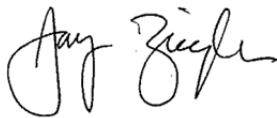

Jay Ziegler
Director, External Affairs & Policy
The Nature Conservancy, California Chapter
Jay_Ziegler@tnc.org
(916) 449-2857

Attachment

Comments on the Long-Term Water Transfers Draft Environmental Impact Statement / Environmental Impact Report (Draft EIS/EIR) – The Nature Conservancy

1. Environmental commitments are inadequate to avoid or mitigate impacts, and must give environmental consequences a “hard look.”

The Draft EIS/EIR includes environmental commitments to mitigate for the impacts of the proposed long-term transfers. The Bureau of Reclamation’s NEPA Handbook describes “environmental commitments” as “written statements of intent made by Reclamation to monitor and mitigate for potential adverse environmental impacts of an action associated with any phase of planning, construction, and operation and maintenance (O&M) activities. It is a term used by Reclamation to reflect the concept addressed in 40 CFR 1505.3.” Section 1505.3 of part 40 of the Code of Federal Regulations refers to the implementation of mitigation measures. The Draft EIS/EIR also describes the environmental commitments as comparable to the mitigation measures required under CEQA. Thus, the environmental commitments are intended to be mitigation measures.

NEPA requires that the environmental impact statement give a “hard look” at the environmental consequences of the proposed project. *Minnesota Public Interest Research Group v. Butz*, 541 F.2d 1292, 1301 (8th Cir. 1976), quoting *Kleppe v. Sierra Club*, 96 S.Ct. 2718 (1976). With respect to mitigation measures, a “hard look” requires that the measures “be discussed in sufficient detail to ensure that environmental consequences have been fairly evaluated.” *Carmel-by-the-Sea v. U.S. Dept. of Transportation*, 123 F.3d 1142, 1154 (9th Cir. 1992) (internal citation omitted). “A mere listing of mitigation measures is insufficient to qualify as a reasoned discussion.” *Northwest Indian Cemetery Protective Assoc. v. Peterson*, 795 F.2d 688, 697 (9th Cir. 1986), *rev’s on other grounds*, 108 S.Ct. 1319 (1988). Failure to include a “reasonably thorough discussion of mitigation measures . . . would undermine the action-forcing goals of [NEPA].” *Carmel-by-the-Sea, supra*, at p. 1154.

CEQA requires that an EIR describe in detail “[m]itigation measures proposed to minimize significant effects on the environment.” (Pub. Resources Code, § 21100, subd. (b)(3).) The CEQA Guidelines, the implementing regulations for CEQA^[1] set forth the detail required for an adequate description of mitigation measures. Section 15126.4, subdivision (a)(1) provides that an “EIR shall describe feasible measures which would minimize adverse impacts.” And section 15126.4, subdivision (a)(2) requires that “[m]itigation measures must be fully enforceable through permit conditions, agreements, or other legally-binding instruments.”

The environmental commitments included in the project description are inadequate as mitigation measures under both NEPA and CEQA. The descriptions are perfunctory and conclusory. For example, with respect to the impact on fisheries, the Draft EIS/EIR concludes without analysis that “The environmental commitments described in Section 2.3.2.4 incorporated into the project will reduce or eliminate significant impacts to fisheries resources and fish species of management concern. No additional mitigation is required.” (Draft EIS/EIR Ch. 3, § 3.7.4.) Presumably based on this conclusion, the Draft EIS/EIR goes on to conclude that “[n]one of the action alternatives would result in potentially

^[1] 14 Cal. Code Regs., § 15000 et seq.

significant unavoidable impacts on fisheries.” (Draft EIS/EIR Ch. 3, § 3.7.5.) Section 3.7.4 does not specify which of the environmental commitments will mitigate for impacts to fisheries or how that mitigation is expected to occur. More significant, none of the environmental commitments described in Alternative 2, the Proposed Action, addresses impacts to fisheries or measures for protecting fisheries. The Draft EIS/EIR fails to fully describe impacts to fisheries and mitigation for those impacts the requisite hard look and therefore is inadequate.

3

With respect to wetland plants and wildlife, the Draft EIS/EIR Section 3.8, page 3.8-64 states that: “The reduction in available habitat in rice fields and the associated reduction in the availability of waste grains and prey items as forage to wildlife species that use seasonally flooded agriculture for some portion of their lifecycle, could result in potentially significant effects to those species. These impacts are reduced by the environmental commitments in Section 2.3.2.4.” There is no elaboration or discussion of the rationale for this conclusion. It is not evident from the list of environmental commitments how any of the commitments would reduce the impacts to migratory birds and other wetland-dependent species that use flooded agricultural land to a less-than-significant level.

4

At a minimum, environmental commitments or mitigation measures should build on previously accepted protective measures that were determined through robust analysis. For example, environmental commitments should at a minimum include all of the giant garter snake protections that were included in the 2009 and 2010 biological opinions.

2. Environmental commitments to address impacts to migratory and resident waterbirds must be expanded based on best available science and consider cumulative impacts from all sources of habitat reduction in the Central Valley.

The one environmental commitment listed in Section 2.3.2.4 that is specifically written to mitigate for potentially significant impacts to birds states that minimizing cropland idling transfers in the Butte Sink will limit reductions in over-winter forage for migratory birds. As described in the Central Valley Joint Venture (CVJV) Implementation Plan as well as many peer-reviewed journal articles, known wintering areas for migratory waterbirds as well as priority habitat for shorebirds in spring and late summer extend far beyond the Butte Sink. Additionally, simply minimizing idling transfers in a specific area will not minimize the impact of the Proposed Action on migratory birds and resident waterfowl, as there will still be an overall reduction of available habitat in the Sacramento Valley due to the Proposed Action. Comparing the net reduction in available quality foraging habitat and bioenergetics (food) supply to the needs of the bird population across the Valley is the more appropriate metric to gauge impacts; this type of analysis was done as part of the Bay Delta Conservation Plan EIS/EIR, but not for this Draft EIS/EIR.

5

Crop idling transfers described in the Proposed Action will particularly reduce available habitat and forage in the Sacramento Valley in dry years. Although the Draft EIS/EIR limits idling to 51,473 acres of rice per year, this does not account for the impact already dry conditions may be having on habitat, the majority of which is now provided by flooded agricultural land. Chronic drought conditions over the last 3 years have led to fewer and fewer acres of flooded habitat available for birds at key times and places during their annual Pacific Flyway migration. This year conditions are particularly bad with abundant birds arriving from a good breeding season in the arctic only to find overcrowded conditions on available flooded habitat areas. Our scientists remain vigilant for cholera and botulism outbreaks that may impact special status species. We are so concerned that, with private funding, TNC has been working with

6

landowners to create flooded habitat conditions thousands of acres as an emergency backstop to severe shortages in migratory bird habitat during this drought year.

6

Although the Draft EIS/EIR describes the 51,473 acre limit as roughly equivalent to 10.5% of the average land in rice production from 1992 to 2012 (page 3.8-69), only about 140,000 acres of typical rice acreage was in production this year¹, and only about 50,000 acres of those were flooded for post-harvest decomposition, leaving only a small fraction of critical habitat available at critical times to migrating birds. Increased idling of compatible crops from the Proposed Action, particularly in dry years, will place additional pressure on the already-stressed refuges and compatible agricultural habitats, potentially resulting in significant impacts to species that depend on those habitats. There are ways to quantify this impact; for example, Ducks Unlimited has estimated that a “25 percent reduction in the number of acres in rice production would result in a loss of capacity to support about 600,000 ducks.”²

7

The fourth environmental commitment listed in the Draft EIS/EIR states that Reclamation will provide maps to the USFWS showing the parcels of riceland that are idled, but provides no further details about the use of these maps or FWS input will mitigate potential impacts described in the Draft EIS/EIR. How will the FWS use this information to make decisions regarding the Proposed Action? Will these maps be developed in conjunction with the FWS prior to the transfer, or after idling decisions are already made? How will this mitigate potential environmental impacts, particularly to terrestrial resources such as migratory birds?

8

Environmental commitments should be added that minimize the extent of idled land allowable in a basin so that it does not fall below CVJV habitat objectives or other protective, biologically-based thresholds. A maximum allowable percentage of idled rice should be set by county, accounting for all sources of fallowing, including drought and other transfer programs. These limits should be developed with biological analysis that demonstrates the impact on wetland-dependent species will not be significant. For example, bioenergetics modeling (such as TRUMET³) should be done to assess the impact that crop idling transfers and other habitat reductions cumulatively will have on available food supplies in various water year types, and establish limits that provide adequate food supply. Maps should be developed which compare available shallow mudflat habitat with and without the Proposed Action to gauge potential impacts to shorebird habitat at their critical migration periods.

9

To lessen impacts to migratory birds, we recommend that the environmental commitments and mitigation measures incorporate consultation with the CVJV partner organizations as well as the FWS, and that the process for review and enforceability be described in detail in the Draft EIS/EIR. The science and conservation organizations and agencies that comprise the CVJV, including the Bureau of Reclamation, work collaboratively to protect, restore, and enhance habitats for birds, in accordance with conservation actions identified in the CVJV Implementation Plan. This Plan sets quantitative habitat objectives based on best available science to ensure sustainable populations of migrant and resident birds in California, a

10

¹ Reported by the California Rice Commission. See, e.g., <http://abcnews.go.com/US/wireStory/california-drought-takes-bite-rice-harvest-26532978>; see also <http://www.capitalpress.com/California/20141021/rice-growers-wrap-up-drought-diminished-harvest>.

² Petrie, M., & Petrik, K. (May 2010). Assessing Waterbird Benefits from Water Use in California Ricelands. Report prepared by Ducks Unlimited for the California Rice Commission. Sacramento, CA.

³ TRUMET modeling was conducted for the Bay Delta Conservation Plan (“BDCP”) environmental documents.

critical area which has lost over 90 percent of its wetlands, within the context of the habitat in the entire Pacific Flyway. The Plan's objectives incorporate a baseline of habitat expected to be provided by private lands. Habitat provided by private wetlands and post-harvest flooded agricultural land is depended on to provide 60 percent of the energetic needs of waterfowl in the Central Valley during winter as well as vital nesting and brooding habitat for many other species.

Partner CVJV organizations, including TNC, have completed studies that establish likelihood of occurrence of shorebirds and other priority migratory bird species over time and space throughout the Central Valley, and have developed maps which should be used to establish where and when crop idling or shifting transfers could occur each year under the Proposed Action to minimize impact to these species. TNC would welcome the opportunity to work with project proponents along with state and federal agencies to advise appropriate use and interpretation of this best available science to minimize impacts to shorebirds and other species, but this must be explicitly described in the environmental commitments or mitigation measures. Such scientific evaluation should consider impacts to flows, floodplains, riparian habitat, and wetlands that reflect multiple habitat values.

Environmental commitments should include such actions as creating surrogate habitat at key times of year near the idled land. The Proposed Action should be linked to the environmental commitment; for example, flooding idled rice fields using a small reserved proportion of the total quantity of water approved for a transfer could provide habitat for migrating birds at key times of year, while also allowing most water to be transferred. This type of action, in combination with others, could help reduce the impact of some rice idling.

3. Potential significant impact on Reclamation's ability to deliver water to refuges should be analyzed and lessened through environmental commitments.

We are concerned that expanded transfers through the Delta will affect the Refuge Water Supply Program's ability to acquire, convey, and deliver water to refuges south of the Delta, a statutory obligation of Reclamation per the Central Valley Project Improvement Act (CVPIA).

The Draft EIS/EIR does not analyze the proposed water transfers' impacts on CVPIA refuges, although with increased competition for water conveyance through the Delta, the impacts to these public and private wetlands could be significant, especially in drought years south of the Delta. This year, for example, East Bear Creek Unit (within the San Luis National Wildlife Refuge Complex) and Kern National Wildlife Refuge are receiving very little water due to conveyance constraints and limited water availability. Wetland habitat there will be impacted for several years by these water shortages. With additional competition for water, reduced water availability, and increasing water costs, the Proposed Action could only make the situation more challenging.

The Environmental Setting should include a description of state wildlife areas and federal wildlife refuges. This seems to have been neglected in this Draft EIS/EIR, even though some of the participating agencies are involved in conveying refuge water and Reclamation is responsible for its delivery under CVPIA. Potential significant impacts from the Proposed Action should include water supply impacts to CVPIA wildlife refuges and the special status species they support. An independent panel convened to review the Refuge Water Supply Program (RWSP) in 2008-2009 found that, "The inability to consistently deliver firm and dependable Incremental Level 4 Water has, on occasion, pre-empted spring and summer

10

11

12

13

irrigations and maintenance of pond water, which has compromised the potential to stimulate germination of some plants, to maximize seed production, or to maintain summer pond water, which is required for successful breeding and survival of some of the sensitive and at-risk species that depend on the wetland habitats in refuges.”⁴ Because refuges already receive less water than what is required by CVPIA, further declines in refuge water deliveries could result in potentially significant impacts to these habitats and the special-status species they support.

13

The Draft EIS/EIR (page 2-18) states that transfers through the Delta will be “limited to periods when capacity at C.W. ‘Bill’ Jones Pumping Plant (Jones Pumping Plant) and Harvey O. Banks Pumping Plant (Bank Pumping Plant) is available typically from July through September, and only after Project needs are met.” The Draft EIS/EIR is not explicit about whether refuge water deliveries are considered a Project need. Because delivery of Level 2 and Incremental Level 4 water to refuges is a Central Valley Project obligation required by CVPIA Section 3406(d), we believe that Project needs implicitly include refuge water supplies, and that Level 2 and Incremental Level 4 water should have priority over the water transfers proposed in this Draft EIR. However, if Reclamation does not consider refuge water a Project need, then *the Draft should analyze how the Proposed Action could impact water deliveries to the south of Delta refuges, and how any potentially reduced deliveries could impact migratory birds and other species that depend upon the refuges.*

14

Currently the RWSP does not deliver Full Level 4 water supplies to all refuges. The 2013 CVPIA Annual Report “Chapter 6 - Progress to Date Toward CVPIA Performance Goals” reported only 39% progress towards acquiring Incremental Level 4 supplies to date and 36% progress towards conveying Incremental Level 4 water supplies, although 100% attainment was required by 2002.⁵ The Nature Conservancy has worked for several years to understand these constraints and is currently working with Reclamation and CVP agricultural contractors to develop pilot projects that help address these constraints. One key constraint relevant to the Proposed Action is the increasing costs of acquiring and conveying water to refuges. Currently, because of budget and policy constraints and water availability, the RWSP relies primarily on spot-market water purchases rather than permanent acquisitions to provide some Incremental Level 4 water supplies to refuges. The increasing costs have outpaced the RWSP’s limited annual budget to meet Full Level 4 water supplies, resulting in less and less water acquired and delivered each year. The Proposed Action could increase the price of available spot-market water even more, which would impact the RWSP’s ability to purchase Incremental Level 4 water supplies, further impacting CVPIA refuge water deliveries and the waterbird populations they support. *The Draft EIS/EIR should analyze how the Proposed Action will impact water prices, and whether price changes will affect Reclamation's ability to meet its refuge water obligations under CVPIA.*

15

To help mitigate impacts to refuge water supplies and the habitats they support, *we recommend an environmental commitment be added that makes a percentage of each transfer available for purchase by the Refuge Water Supply Program towards meeting Full Level 4 water obligations.* That amount would not be credited to the transferor if the RWSP chose to purchase it, and instead it would be schedulable by

16

⁴ CVPIA Refuge Water Supply Program Independent Panel Review Report. “Undelivered Water: Fulfilling the CVPIA Promise to Central Valley Refuges”, dated November 3, 2009.)

⁵ Bureau of Reclamation, U.S. Fish and Wildlife Service, California Department of Fish and Wildlife. 2014. Central Valley Project Improvement Act Public Law 102-575 Annual Report Fiscal Year 2013. January.

the Interagency Refuge Water Management Team for delivery to any delivery-short refuge, with reimbursement to the transferor by the RWSP.

The RWSP could also more efficiently manage its existing water supplies across all refuges and meet CVPIA mandates if north-to-south-of-Delta conveyance of RWSP-acquired water supplies and conserved refuge water was less constrained. The Proposed Action increases those constraints by increasing competition for conveying water transfers through the Delta. The situation is made even more difficult because refuges were not included in the Draft EIS/EIR as potential transferors or recipients of this water. To improve this situation and minimize the potential for significant impact, *we recommend that an environmental commitment be added that allocates a percentage of allowable CVP transfer capacity each month to the RWSP.* Under the commitment, the RWSP would have the first opportunity to schedule water during the window up to a certain flow or volume, if needed for optimal use of available refuge water supplies. Alternatively, *an environmental commitment could be added that reserves a percentage of each transfer through the Delta for use by the RWSP towards meeting Full Level 4 water obligations.* The full transfer quantity would be transferred through the Delta when scheduled by the transferring parties, but once south of the Delta, the refuge-reserved percentage could be stored in San Luis Reservoir for later delivery to a south-of-Delta refuge.

16

4. Impacts from groundwater substitution transfers should be accurately simulated and more clearly illustrated. The Draft EIS/EIR should account for compounding impacts of multiple or repeated groundwater substitution transfers over time, and water supply and environmental impacts should be mitigated until recovery is achieved.

4a. The connection between groundwater and surface water must be accurately simulated.

The ability to rigorously simulate interaction of groundwater and surface water is of great importance to assessing the potential environmental impacts of groundwater substitution transfers in this EIS/EIR because groundwater substitution pumping ultimately comes at the expense of streamflow. A coupled surface water-groundwater model provides for simultaneous solution of flow conditions in these physically coupled systems, thereby allowing for more representative simulation of the interaction of surface water and groundwater. Unfortunately, the groundwater model used for this Draft EIS/EIR analysis (SACFEM2013) is not coupled in this way. Instead, water levels (stages) in the streams are specified by the user. This does not reflect the reality that stream stage rises and falls through time during operation of surface water facilities and changes in groundwater pumping. This issue is likely most important for smaller streams, where changes in stage may lead to more significant changes in flow to or from the groundwater basin. Using SACFEM2013, how were specified stream stages arrived at, and are they ‘conservative’ relative to streamflow depletion impact analysis? *The Draft EIS/EIR should include a discussion of how stream stages were decided upon, the potential errors that could arise from specifying heads in streams with this model, and demonstrate why these potential errors are negligible in evaluating environmental impacts in both large and small streams or why they do not compromise the validity of the impact evaluation.*

17

4b. The impacts on riparian communities from lowered groundwater levels must be avoided or mitigated.

Section 3.8.2.4.1 of the Draft EIS/EIR states that the flow in many small streams would be impacted by more than 10 percent with implementation of groundwater substitution transfers described in the Proposed Action. Figure 3.3-29 shows that, as a result of these stream depletions, water table levels will be lowered more than one foot over much of the project area including along many streams and tributaries, and in many places drawdown may be as much as five feet. Natural riparian communities for some distance away from the rivers (the riparian corridor), and along many miles of rivers, could be impacted by these lowered groundwater levels; however, the Draft EIS/EIR only addresses potential impacts to riparian communities due to streamflow depletions—it does not estimate the impacts on natural riparian communities from the lowered water levels that will result from the pumping.

18

The impacts of these groundwater level drawdowns on riparian corridor communities need to be addressed. This is especially important since, as noted on page 3.8-47, groundwater levels that decline any deeper than key threshold levels (estimated at 15 feet below ground surface on page 3.8-47) will not meet the needs of many plants. In this light, declines of 1 to 5 feet could be significant in many riparian areas, and these impacts must be avoided or mitigated, thus the importance of detailed and transparent modeling and monitoring.

4c. Streamflow depletion resulting from groundwater substitution transfers must be fully accounted for, and the compounding quantity and duration of impacts must be reflected in the analysis and mitigation described in detail in Mitigation Measure WS-1.

Groundwater and surface water systems are interconnected; as a result, groundwater pumping ultimately leads to what is termed “streamflow depletion.” This streamflow depletion may be the result of either reduced groundwater discharge to the stream, in which case the stream experiences less gain (groundwater inflow) than before pumping was initiated, or it may be the result of additional induced infiltration from the stream, in which case the stream loses more water than it did prior to groundwater pumping. According to well established principles of groundwater-surface water systems, total stream depletion (from both reduced discharge and induced infiltration from the stream) will trend towards the amount of groundwater pumping in a given area over time, less other potential boundary effects such as subsurface outflow from the basin or changes in small watershed inflow.⁶

19

Streamflow depletion can occur for many years after groundwater pumping has ceased, and this long-term streamflow depletion and associated impacts must be considered and accounted for. Long-term impacts from multiple years of transfers are especially important to account for since impacts are additive and therefore potentially more severe. *The Draft EIS/EIR should include a full water budgeting accounting of where pumped groundwater is coming from and the related duration of streamflow depletion to disclose the location, magnitude, and duration of potential impacts.*

⁶ The technical aspects of these issues, and their importance to proper management of surface water-groundwater systems, is well-described in “Groundwater and Surface Water, a Single Resource” (USGS Circular 1139, 1998), and “Streamflow Depletion by Wells – Understanding and Managing the Effects of Groundwater Pumping on Streamflow” (USGS Circular 1376, 2012).

Simulations performed by TNC using DWR's C2VSim integrated ground and surface water model of the Central Valley indicate that groundwater pumping at scales similar to the Proposed Action affects a large area and, very importantly, that streamflow depletion from even a single year of such pumping persists for decades⁷. The timing of these impacts is illustrated in Figure 1, below.

Figure 1 shows that streamflow depletion is significant for many years after pumping has ceased, with only about 65 percent of ultimate stream depletion expressed even 5 years after pumping has stopped. It takes 25 years for the system to nearly fully "recover" (90 percent "depletion recovery"). Although different assumptions regarding well locations and depth will lead to differently shaped depletion curves, the best information available suggests that impacts from pumping will persist for decades for wells distributed over wide areas and depths, as is the case for the Proposed Action. In contrast, Figure 3.1-3 of the EIS/EIR does not reflect this full duration of impact, at least as expressed in percent changes in CVP and SWP exports. Please explain how the modeling done for this Draft EIS/EIR accounts for the compounding impacts to water supplies from multiple years of pumping, and how the duration of impact through full recovery will be accounted and mitigated under Mitigation Measure WS-1.

20

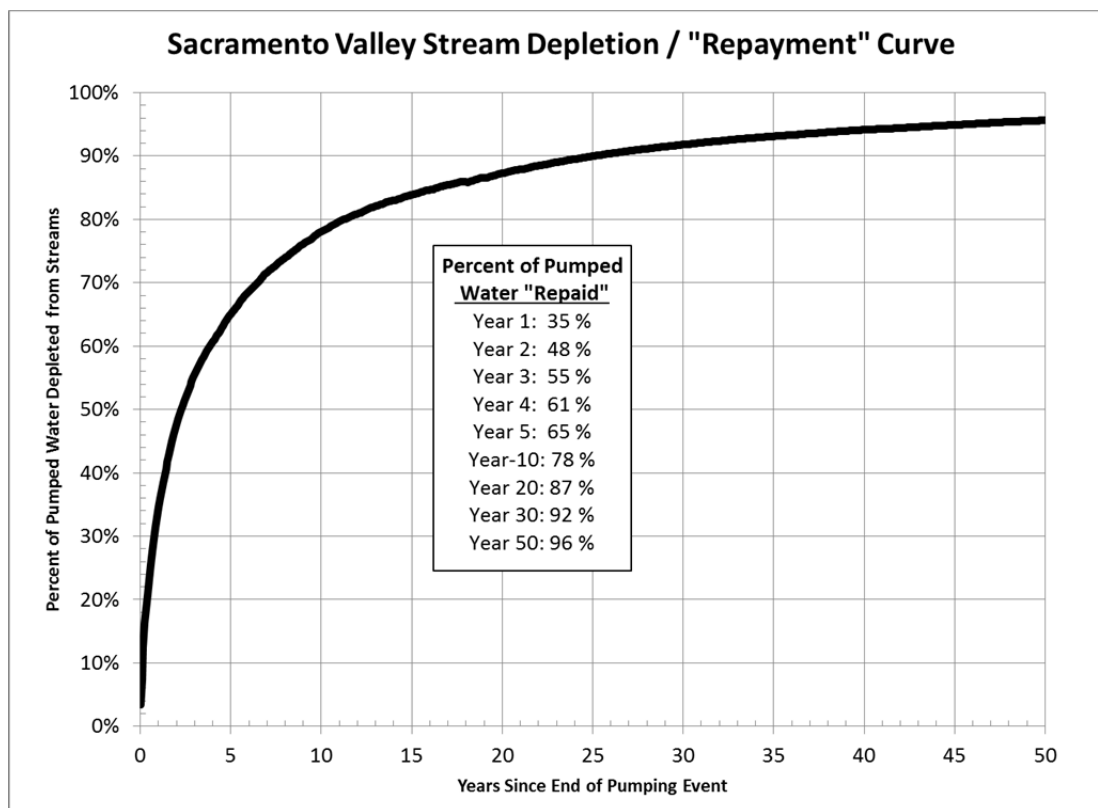

Figure 1. Normalized Stream Depletion Curve. (from TNC 2014, normalized to the simulated amount pumped in one season.)

⁷ The Nature Conservancy (TNC), 2014. "Assessment of Surface Water and Groundwater Conditions and Interaction in California's Central Valley, Insights to Inform Sustainable Water Management," June.

To appropriately characterize the potential water supply and environmental impacts of the Proposed Action, the Draft EIS/EIR must more clearly answer the question, “Which streams are likely to be depleted, by how much, and for how long?” The EIS/EIR needs to better account for the source of pumped water and its related cumulative impacts over time to both water rights holders (both export rights and in-valley rights) and the environment, and avoid or fully mitigate for those impacts. To fully mitigate for groundwater substitution pumping impacts on water supplies, Section 3.1.4.1, *Mitigation Measure WS-1, must describe in detail how the streamflow depletion factor will be developed, account for compounding, and be applied over the duration of the project and beyond until recovery is achieved.*

21

In recognition of the potentially significant environmental impacts of streamflow depletion from groundwater substitution transfers, *the secondary effects of changes in groundwater levels resulting from the Proposed Action (Section 3.3.2, page 3.3-59) should include: “(4) a reduction in groundwater levels that significantly impacts surface flows (streams or rivers) or the species, habitats, and other beneficial uses of these stream flows.”* Application of Mitigation Measure WS-1 should include consultation with fish and wildlife agencies during annual development of the streamflow depletion factor so potentially significant environmental impacts can be avoided early.

22

5. Environmental commitments should more fully develop a suite of additional actions that ultimately result in additional benefits for nature and provide incentives for those actions such as a transfer priority system to drive their implementation and adoption.

The Central Valley is already highly altered and many aquatic and terrestrial species dependent on its land and watersheds are already on the brink of extinction. The Sacramento Valley has made great advances in using a finite water supply for multiple benefits, such as optimizing diversions so both fish flows, migratory birds, and rice straw decomposition can occur simultaneously, with the same water supply. This progress could be thwarted and significant environmental and water supply impacts could result from transferring hundreds of thousands of acre-feet annually across basins and away from the Sacramento Valley where water is already used for multiple benefits.

To drive improvement and sustainability over time and mitigate for the loss of this progress, we recommend that an additional environmental commitments be included to develop a suite of additional actions that could be done in conjunction with water transfers in such a manner that transfers which also deliver other benefits for nature are prioritized within the system. That is, those agencies or transferring entities which provide the most robust monitoring, wildlife-friendly farming practices, and habitat-protecting regimes should be prioritized over transfers with less attention to environmental values and mitigation. We envision such practices will require both adequate incentives and monitoring to demonstrate performance. For example, the timing, capacity or priority to convey a particular transfer through the Delta could be enhanced to a degree proportional to the benefits created for nature by a chosen set of actions. The suite of actions and their relative value to nature could be developed in conjunction with input from TNC and other NGOs in consultation with state and federal wildlife agencies. Such actions should be designed in a manner that provides flexibility to meet multiple habitat values and applies new, cutting-edge ways to use water for multiple benefits on private and public lands and waterways. Implementing such a program would help drive conservation as a co-equal priority to water transfers designed to benefit urban and agricultural water uses, and will accommodate a broader use of water than otherwise would be accomplished through large scale water transfers.

23



LONG-TERM WATER TRANSFERS DRAFT EIS/EIR COMMENT SHEET



There are several options to provide written comments. You can provide your written comments by turning in this form at the public meeting. You may also e-mail your comments directly to bhubbard@usbr.gov with the subject line "Long-Term Water Transfers" or mail this form to the Bureau of Reclamation (mailing address is on the back of this card). Whatever method you choose, please note that all written comments must be received by **5:00 p.m. (Pacific Standard Time) on December 1, 2014.**

PLEASE PRINT CLEARLY. PLEASE NOTE THAT ALL COMMENTS BECOME PART OF THE PUBLIC RECORD.

Name: Bob Adams

Organization (If applicable): _____

Address: 21 B Cameo Dr. Chico, CA 95973

Phone: (530) 624-1945 Fax: () _____

E-mail: _____

Date: 10/21/14

Comment: Don't even think about taking

water out of Butte County. We'll
be in your face, starting now. I've
never given over \$20 to any cause.

Starting now, Aqualiance gets all my
spare cash.

What kind of rotten, disassociated,
(with any real people) bastards would
even try this kind of crap.

Just expect max flat, assholes.

Oct 22, 2014

AQUA-266C

IN02

Brad Hubbard,

1

I would like to protest the 10 year water transfer plan and express my frustration at the short period of time for public input.

2

Public awareness in northern CA is growing fast concerning the San Joaquin Valley's misguided water wishes. Along with ground water levels dropping and the ever-expanding tree farms around us, the smell of fear is pushing a greedy political process.

3

And the fish — ?

Geoffrey Baugher
Box 977
Orland CA,
95963

977
Orland, CA
95963

SACRAMENTO CA 957
23 OCT 2014 PM 3 L



Long-Term Water Transfers Draft ^{EIS}/_{EIR}
Brad Hubbard, Bureau of Reclamation
2800 Cottage Way MP 410
Sacramento, CA
95825

Buckman, Carolyn

From: Hubbard, Bradley <bhubbard@usbr.gov>
Sent: Wednesday, November 26, 2014 10:06 AM
To: Frances Mizuno; Buckman, Carolyn; Veronese, Gina
Subject: Fwd: LONG-TERM WATER TRANSFERS

Here is a comment email, received today.

----- Forwarded message -----

From: <lindzer2@aol.com>
Date: Tue, Nov 25, 2014 at 4:49 PM
Subject: LONG-TERM WATER TRANSFERS
To: bhubbard@usbr.gov

Hello,

As a resident of Northern California, I am opposed to the Long-Term Water Transfers of Northern Ca. groundwater that is proposed by the Bureau of Reclamation.

1

Located in Northern Ca., the Tuscan Aquifer is one of the last remaining intact aquifers. Pumping up to 600,000 acre feet of our groundwater per year for 10 years will cause irreparable harm to the Tuscan Aquifer and Northern Ca. as a whole and only serve to benefit a very few water profiteers at the expense of the rest of the population_ and the environment_ our beloved oak trees are already at risk.

2

California is experiencing of one of the worst droughts in history. The lakes and reservoirs in Northern California are already at or below historic lows. Most streams that used to run year around are very low or dry. Many wells in and around the entire North State are running dry. Long range weather forecasts indicate there will not be any significant rainfall again this year to recharge the groundwater or refill the lakes and reservoirs and yet this proposal would take our water and sell it to those that have already decimated their own water sources.

3

Rain and snow melt flows into Shasta Dam and Lake Oroville and then is shipped south to Central and Southern Ca. Northern Ca. water is already heavily diverted and now there is this proposal to take our groundwater. Most cities and towns in Northern Ca. rely solely on groundwater. If that is pumped dry, there are no other alternative water sources.

Over and over again, aquifers throughout California have been overdrawn (more water is taken out than is replaced) and left permanently damaged. Irreparable subsidence (the land sinks when the water is drained from the aquifer) has been the result of many of these aquifers. As only one example, the San Joaquin Valley has seen irreparable subsidence (land sinking) by as much as 25 feet from 1925 to 1977.

California is a semi arid desert. California farmers use 80% of all fresh water available in the state. It makes no sense to allow farmers to continue to use flood irrigation and plant permanent high water use crops in a desert and continue to sacrifice water sources in one area to satisfy the thirst for water in another. Cities that do not have a sustainable source of fresh water need to reuse their water through tertiary water treatment and desalination plants and implement strict conservation measures. Using billions of gallons of fresh water for hydraulic fracturing and then polluting the remaining fresh water with the waste water is absolutely insane. Continuing to dry up sources of fresh water is short sighted. Unless we stop this trend, there will be no fresh water left for crops, environment or people.

4

I am sure you saw the recent 60 minutes episode on this subject which aired November 16. Studies by Hydrologist Jay Famiglietti at UC Irvine should be taken into account as part of the EPA impact study.

5

Sincerely,

Linda Calbreath
25 Blackstone Ct,

Chico, CA 95973
530-864-7417

--
Thanks,

Brad

October 25, 2014

Mr. Brad Hubbard
Bureau of Reclamation
2800 Cottage Way, MP-410
Sacramento, CA 95825

RE: Long Term Water Transfer Draft EIS/EIR

Dear Mr. Hubbard:

It has only been in recent days that this abhorrent proposal has come to light in our neighborhood. I may not be up on all current events, but because my neighbors, who are farmers, doctors and lawyers, were unaware as well, it is obvious this proposal is sneaky and dirty handed.

The San Joaquin Valley has obviously not been a good steward of their water and now you want to penalize us and put our lively hoods and households in a very grave situation. Everyday I turn on the faucet, hoping my well will still produce. My neighbor, ½ a mile away, just drilled a new well at a cost of \$30,000+. Although, this looks like it's just a transfer of surface water via our canal system, it will mean further tapping of our ground water, which has dropped significantly in the past few years. To approve a proposal, based on a study of water years dating back 40 years, knowing we are in the worst drought on record, is incomprehensible.

I urge you to look at the real picture here and take the \$\$\$ out of the equation.

Sincerely,



Lynne Elhardt
Chico, CA

OCT 27 2014

October 28, 2014

Mr. Richard
University of Florida
100 University Blvd
Gainesville, FL 32611

Buckman, Carolyn

From: Hubbard, Bradley <bhubbard@usbr.gov>
Sent: Friday, October 31, 2014 8:55 AM
To: Buckman, Carolyn; Veronese, Gina; Frances Mizuno
Subject: Fwd: Managing Water in the West

----- Forwarded message -----

From: **Ginny** <vfreeman@digitalpath.net>
Date: Fri, Oct 31, 2014 at 8:10 AM
Subject: Managing Water in the West
To: bhubbard@usbr.gov

The Sacramento Wild Life Refuge outside of Willows, CA, needs to leave their water where it is. Our area is already groundwater deficient in it's upper levels due to over drafting in the lower levels. I know, because in my area alone, our ground water has "recharged", and I say that lightly. Our upper strata water "came back" after the local nut growers and corn growers stopped irrigating. They ****robbed**** us of our domestic well water, and since they quit sucking the water out of the ground for THEIR money making farm practices for the year, we have GAINED 35 FEET. (Look over your head and up 35 feet for A CONCEPT of how MUCH that is, then think of how many acres there are of that 35 foot gain of water below us.) This water is going to all disappear once the farmers, once again, steal our water for their nut crops.

1

KEEP GLENN COUNTY WATER IN GLENN COUNTY and let Merced pump for theirs!

Virginia Freeman

(530) 934-7658

--
Thanks,

Brad

Buckman, Carolyn

From: HUBBARD, BRADLEY <bhubbard@usbr.gov>
Sent: Tuesday, October 21, 2014 12:49 PM
To: Buckman, Carolyn; Veronese, Gina
Subject: Fwd: Water transfer

----- Forwarded message -----

From: FINCH HEATHER <hfincheyecarepro@yahoo.com>
Date: Tue, Oct 21, 2014 at 10:36 AM
Subject: Water transfer
To: bhubbard@usbr.gov

To Whom it may concern

I am writing to strongly disagree with the proposed 10 year water transfer of 195 billion gallons PER YEAR to the San Joaquin Valley. ARE YOU INSANE???? With the alarming drought that we are going through and PEOPLES wells going dry right and left, how can you even dream that this is going to happen without a devastating effect to Northern California? Instead of using this water transfer as a pipe dream(literally) why don't you start building systems through out the area for Rain Harvesting?

1

Thank you for your time. Please show some creative thinking ,using your brains and come up with a more sustainable plan for our future.
Heather Gray

--
Thanks,

Brad

Buckman, Carolyn

From: Hubbard, Bradley <bhubbard@usbr.gov>
Sent: Monday, December 01, 2014 9:22 AM
To: Buckman, Carolyn; Veronese, Gina; Frances Mizuno
Subject: Fwd: Concerns about water transfers!

I believe this is the same comment email sent to Frances...

----- Forwarded message -----

From: Steven Hammond <schammond@earthlink.net>
Date: Sun, Nov 30, 2014 at 8:42 AM
Subject: Concerns about water transfers!
To: bhubbard@usbr.gov

I am extremely concerned that the proposed water transfers from Northern California will result in irreparable damage to the aquifer in the area where I live, in Chico, California. I have been following this issue for years, and am convinced that the research on the negative effects of the proposed transfers has been strikingly inadequate. It is no secret that a great deal of the proposed water to be transferred (SOLD) will be substituted by the sellers in my area by "replacing" the water they sold with groundwater, which could deplete the aquifer in this area terribly. Many local wells in outlying areas have already been going dry.

I truly believe that the effects of this could be precipitate a disaster for my home - have you ever been to Chico? It is a very lovely small city for which the saving grace is a well-established canopy of trees. It is not at all a stretch to project that if the groundwater levels fall sufficiently this could become another Owens Valley.

Additionally, I think that factors such as the wasteful use of water in the southern districts who want the water have not been adequately addressed either. To continue growing nut trees in the desert, which takes tons of water, is simply not a good reason to deplete another region's water supply! The possibility of stopping this practice, and other possible ways of conserving and using water appropriately, have not been given enough consideration!

I truly think that the proposed massive water transfers are merely an example of robbing Peter to pay Paul - and are not only a mistake, and just plain wrong, but are also very short-sighted and need to be stopped until careful and longitudinal research can be completed.

I have to admit I mistrust your intentions, given what has occurred in this matter so far. I'd like to be shown that you are not in the pocket of those with the money to "BUY" what really shouldn't be available just because they want it, and because there are those who will "SELL" what isn't really theirs to sell: water.

Sincerely,
 Steven Hammond



LONG-TERM WATER TRANSFERS DRAFT EIS/EIR COMMENT SHEET



There are several options to provide written comments. You can provide your written comments by turning in this form at the public meeting. You may also e-mail your comments directly to bhubbard@usbr.gov with the subject line "Long-Term Water Transfers" or mail this form to the Bureau of Reclamation (mailing address is on the back of this card). Whatever method you choose, please note that all written comments must be received by **5:00 p.m. (Pacific Standard Time) on December 1, 2014.**

PLEASE PRINT CLEARLY. PLEASE NOTE THAT ALL COMMENTS BECOME PART OF THE PUBLIC RECORD.

Name: Scott Lape

Organization (If applicable): _____

Address: 1355 Kentfield Road Chico, CA 95926

Phone: (530) 342-2418 Fax: () _____

E-mail: ~~scottlape@usbr.gov~~ scottlape@comcast.net

Date: Oct. 21, 2014

Comment: I'm strongly opposed to any water transfers out of Northern California. Local groundwater supplies are seriously depleted, and there is no reason to expect that the aquifer will regenerate any time soon. We don't know what the effects of climate change will be, and the precautionary principle suggests that we plan for the worst.

1

2

We have seen ~~what~~ the ~~destructive~~ effects of unsustainable agriculture in the San Joaquin Valley. Why should we allow greedy agribusiness to destroy the Tuscan aquifer the way they have destroyed the aquifers in the San Joaquin Valley?

3



LONG-TERM WATER TRANSFERS DRAFT EIS/EIR COMMENT SHEET



There are several options to provide written comments. You can provide your written comments by turning in this form at the public meeting. You may also e-mail your comments directly to bhubbard@usbr.gov with the subject line "Long-Term Water Transfers" or mail this form to the Bureau of Reclamation (mailing address is on the back of this card). Whatever method you choose, please note that all written comments must be received by **5:00 p.m. (Pacific Standard Time) on December 1, 2014.**

PLEASE PRINT CLEARLY. PLEASE NOTE THAT ALL COMMENTS BECOME PART OF THE PUBLIC RECORD.

Name: Linda Lokse

Organization (If applicable): _____

Address: 7833-Co. Rd #29

Phone: (530) 934-4931 Fax: () _____

E-mail: _____

Date: 10-21-14

Comment: I do not approve of any transfers of ground water.
Linda Lokse

1

No action / No Project is the only choice.

Buckman, Carolyn

From: Hubbard, Bradley <bhubbard@usbr.gov>
Sent: Wednesday, November 05, 2014 11:32 AM
To: Buckman, Carolyn; Frances Mizuno; Veronese, Gina
Subject: Fwd: Water Transfers

----- Forwarded message -----

From: John MacTavish <john.mactavish@lpl.com>
Date: Wed, Nov 5, 2014 at 11:20 AM
Subject: Water Transfers
To: bhubbard@usbr.gov
Cc: dmactav33@yahoo.com

Brad,

I attended the water transfer meeting in Chico on October 17th. As instructed, I am submitting the following questions for your response.

- 1. Please provide justification for using a study period ending in 2003? Please include in your response California population changes and farmed acres at the end of 2003 compared with 2013. I would also like to know actual water demands (usage) for the years 2003 and 2013. It would also be helpful to see your projections for future water usage going out for the next 100 years. 1
- 2. Who were the other consultants you considered to provide independent analysis and possible solutions? Was the selection done in a bid for services process? If so, is the RFP and bid submissions available for review? 2
- 3. Please provide the names, addresses, qualifications and phone numbers of the “ Decision Makers”. 3
- 4. Why were there no stakeholders from each of the effected communities/counties included in this process? 4
- 5. Who initiated the water transfer concept? Reclamation or San Luis/Mendota? 5
- 6. Why was the alternative of stopping or reducing tree crop plantings in the areas in need of water not offered as a possible solution? 6
- 7. Why was the alternative of selling surface water entitlements without ground water replacements considered as an option? 7

8. How much ground water in acre feet is in the Tuscan aquifer? Any recent reading within the last year will do. What are the last ten years measurements in acre feet? Please provide the basis/calculation methodology of your response. 8

9. How do we know for certain that groundwater storage will “recharge” over time? This was the vague unsubstantiated claim made in the consultants report. 9

10. This is a personal question to you as one of the “decision makers”, How can you in good conscience support pumping groundwater from a finite/fragile resource (when proof exists of other aquifers being damaged or pumped dry) to farm inappropriate crops in arid land? This is so short sighted and wrong. 10

Thank you in advance for your responses.

John MacTavish, CFP

LPL Financial

901 Bruce Road Ste 280

Chico, CA 95928

530-894-8696

John.mactavish@lpl.com

LPL Financial Member FINRA/SIPC

The information contained in this email is being transmitted to and is intended for the use of only the individual(s) to whom it is addressed. If the reader of this message is not the intended recipient, you are hereby advised that any dissemination, distribution or copying of this message is strictly prohibited. If you have received this message in error, please immediately delete.

--
Thanks,

Brad



LONG-TERM WATER TRANSFERS DRAFT EIS/EIR COMMENT SHEET



There are several options to provide written comments. You can provide your written comments by turning in this form at the public meeting. You may also e-mail your comments directly to bhubbard@usbr.gov with the subject line "Long-Term Water Transfers" or mail this form to the Bureau of Reclamation (mailing address is on the back of this card). Whatever method you choose, please note that all written comments must be received by **5:00 p.m. (Pacific Standard Time) on December 1, 2014.**

PLEASE PRINT CLEARLY. PLEASE NOTE THAT ALL COMMENTS BECOME PART OF THE PUBLIC RECORD.

Name: H. Elena Middleton

Organization (If applicable): Self

Address: 3805 Addys Lane

Phone: (530 345 -1815) Fax: ()

E-mail: envizd@yahoo.com

Date: 10/21/14

Comment:

I strongly oppose the proposed water transfers. I believe that there is not enough knowledge of the potential destructive and irreversible effects on ground water, creeks, environment and north state farms.

GILBERT COSIO, JR., P.E.
MARC VAN CAMP, P.E.
WALTER BOUREZ, III, P.E.
RIC REINHARDT, P.E.
GARY KIENLEN, P.E.
DON TRIEU, P.E.
DARREN CORDOVA, P.E.
NATHAN HERSHEY, P.E., P.L.S.
LEE BERGFELD, P.E.

ANGUS NORMAN MURRAY
1913-1985

CONSULTANTS:
JOSEPH I. BURNS, P.E.
DONALD E. KIENLEN, P.E.

December 1, 2014

Brad Hubbard
U.S. Bureau of Reclamation
2800 Cottage Way
Sacramento, CA 95825

Subject: Comments to Long-Term Water Transfers Environmental Impact Statement/Environmental Impact Report Public Draft

Dear Mr. Hubbard:

Thank you for the opportunity to review and provide comments to the Long-Term Water Transfers Environmental Impact Statement/Environmental Impact Report Public Draft (Draft EIS/EIR). The purpose of this letter is to provide a list of our comments and observations based on our review of the Draft EIS/EIR and information that we have available to clarify details associated with potential water transfer participants identified in the Draft EIS/EIR. We have attempted to identify the specific page and section for our comments; however, there may be other locations in the Draft EIS/EIR where our comments would apply. Following your review of this letter, please contact our office if you require any clarifications or additional information. The following is a list of our comments and observations:

1. Page ES-6, Table ES-2:

Based on data provided by Gilsizer Slough Ranch, the maximum potential transfer quantity should be 4,500 acre-feet. This comment also applies to Table 2-4.

2. Page ES-10, 1st Paragraph:

Identifies that "...a CVP seller would forbear (i.e., temporarily suspend) the diversion of some of their Base Supply...". We believe that a transfer of water involving a CVP seller may also include a portion of the CVP seller's Project Water supply. Thus, we believe the Draft EIS/EIR should cover water transfers involving Project Water to provide flexibility to the potential water transfer participants.

1

2

3. Page ES-10, Section ES.4.1:

We believe there may be opportunities to make surface water available during the month of October. For example, the Draft EIS/EIR should provide for the potential that surface water may be made available by groundwater substitution for rice straw decomposition. Thus, we believe the potential period for surface water made available by groundwater substitution should include April through October.

3

4. Page ES-11, Section ES.4.4:

The description of establishing a baseline for crop shifting should refer to the methodology outlined in the Draft Technical Information for Preparing Water Transfer Proposals (DTIWT) in order to maintain consistency.

4

5. Page 2-17, Table 2-5:

Based on data provided by Gilsizer Slough Ranch, the upper limit for July-September groundwater substitution transfer should be 3,000 acre-feet. This comment also applies to Table 2-7 and Appendix A, Table 5-1.

5

6. Page 2-26, 1st paragraph:

Identifies that water transfers involving Merced Irrigation District (Merced ID) through delivery methods (excluding Banks and Jones Pumping Plants) could be used throughout the irrigation season of April through September. We believe this should be clarified to provide flexibility for these delivery methods to be used throughout the year for water transfers involving Merced ID.

6

7. Pages 3.1-6 through 3.1-12:

Quantities listed in the descriptions of the potential sellers should correspond to quantities in Table ES-2 and Table 2-5. Specifically, the quantities for Conaway Preservation Group, Pleasant Grove-Verona Mutual Water Company, Te Velde Revocable Family Trust, Garden Highway Mutual Water Company, and Gilsizer Slough Ranch should be revised.

7

8. Page 3.1-6, Footnote 3:

Footnote 3 should be clarified to identify the following:

8

“Conaway Preservation Group (CPG) has assigned portions of its water rights

and Sacramento River Settlement Contract to the Woodland-Davis Clean Water Agency (Agency). Amendment No. 1 to CPG's Settlement Contract, which identifies the assignment of 10,000 AF to the Agency, is effective upon the earlier of the Agency diverting water or January 15, 2016. After that time, CPG may receive surface water under the portion assigned to the Agency."

8

9. Page 3.1-8, River Garden Farms:

The description should be clarified to identify that River Garden Farms supplements its surface water supply with groundwater wells (i.e., eliminate reference to "three" groundwater wells).

9

10. Page 3.1-10, Tule Basin Farms:

The description should be clarified to identify that Tule Basin Farms diverts water from the West Borrow Pit of the Sutter Bypass (i.e., eliminate reference to the "Feather River").

10

11. Page 3.1-13, Merced Irrigation District:

The description should be clarified to identify that: "Merced ID supplies water principally for agricultural purposes" (i.e., eliminate reference to the "M&I" purposes).

11

12. Page 3.1-21, Section 3.1.4.1:

Relative to the streamflow depletion factor, in the case that the U.S. Bureau of Reclamation (Reclamation) and/or the Department of Water Resources (DWR) believe that the factor is to be refined for the following transfer season, there should be a date by which the water transfer participants, Reclamation, and DWR discuss potential refinements to the streamflow depletion factor (e.g., by December 1).

12

13. Page 3.2-31 through Page 3.2-50:

It appears that tables identified in Section 3.2 and Sections 3.13 through 3.17 are intended to present the same information for a particular alternative; however, the data in the tables are different. For an example, see Table 3.2-23 and Table 3.17-1. We believe the differences between the relevant tables should be examined in further detail to provide clarification and consistency.

13

14. Page 3.2-41, Last Paragraph:

There may be other circumstances that affect storage in San Luis Reservoir that would not lead to decreased storage for nearly all months of the year, such as transfer water that may be temporarily held in San Luis Reservoir prior to delivery to the buyer. We believe this should be clarified/explained in additional detail.

14

15. Page 3.3-5, 5th Paragraph:

In regard to well completion reports, we believe that groundwater wells approved in 2009 through 2014 should be accepted for future groundwater substitution transfers unless technical evidence indicates use of the well could result in impacts to third parties or the environment. This is consistent with the Addendum to Draft Technical Information for Preparing Water Transfer Proposals dated January 2014, prepared by DWR and Reclamation.

15

16. Page 3.3-29, 1st Bullet:

The land subsidence identified is characterized as “inelastic” from 2013 to 2014. Due to the brief time period following the observed subsidence to date, and considering the persistent drought conditions, we believe that the term “inelastic” should be removed.

16

17. Page 3.3-69, Table 3.3-3:

The following are clarifications to the data listed in Table 3.3-3, as follows:

Conaway Preservation Group: 70-980 feet.
 Garden Highway Mutual Water Company: 115-250 feet.
 Natomas Central Mutual Water Company: 110-960 feet.
 Pelger Mutual Water Company: 4 Wells; 101-485 feet.
 Pleasant Grove-Verona Mutual Water Company: 34 Wells; 99-260 feet.
 Reclamation District 1004: 21 Wells; 56-430 feet.
 River Garden Farms: 9 Wells; 170-686 feet.
 Te Velde Revocable Family Trust: 150-455 feet.
 Tule Basin Farms: 120-405 feet.

17

18. Page 3.3-89, Land Subsidence Bullet:

As stated in the current DTIWT, Reclamation and DWR should coordinate with the water transfer proponent to develop a mutually agreed upon subsidence monitoring program for areas with documented historic land subsidence and higher susceptibility to land subsidence. This should be identified in this section, as the current paragraph seems to indicate that subsidence monitoring is required for all participating sellers; however,

18

subsidence monitoring may not be necessary for each area.

18

19. Page 3.7-1, Section 3.7:

The sub-sections to Section 3.7 refer to time periods for potential water transfers. In order to preserve flexibility for the timing of potential water transfers, we believe Section 3.7 should include additional clarification that water transfers may occur during periods other than July through September. This may also need to be addressed in Appendix A (see Page 3-4, Section 3.6.1). One example of the potential for transfers occurring during other periods is identified on Page ES-9:

19

“Through Delta transfers would be limited to the period when USFWS and NOAA Fisheries find transfers to be acceptable, typically July through September, unless a change is made in a particular water year based on concurrence from USFWS and NOAA Fisheries.”

20. Section 3.10.1.3:

Sacramento County is not included in the Regional Economics analysis. The reason for this is unclear; and should be identified in this section.

20

21. Page 3.10-23, Cropland Idling Acreages:

It is uncertain whether the analysis for the Draft EIS/EIR would limit the crop acreage that may be idled (or shifted) to the estimates identified in this section, including Sections 3.3, 3.8, and 3.9. We believe that these sections should provide for potential adjustments to the maximum acreage idled or shifted to allow for flexibility.

21

Following your review of this letter, please call if you have any questions.

Sincerely,
MBK ENGINEERS

Darren Cordova

Angela Bezzone

Mary McCluskey
501 Hoopa Cir.
Chico CA 95926

Brad Hubbard
Bureau of Reclamation
2800 Cottage Way, MP-410
Sacramento, CA 95825

Dear Mr. Hubbard,

I am writing to express my concern over the Environmental Impact Report of the proposed 10 year water transfer program.

1

I have read the report, and even though I am not a lawyer, it is easy to tell that the report was written with little regard to the impacts to Northern California.

I have also read the letter written to you and to the San Luis & Delta-Mendota Water Authority by the Butte County Board of Supervisors. As a resident of Butte County, I fully support the their position in the letter – that the report is “seriously flawed” and needs revision. I also support their request for an additional 90 days for public review.

2

3

Sincerely,

Mary McCluskey
Mary McCluskey

11/24/2014
11/24/2014
11/24/2014

11/24/2014
11/24/2014

11/24/2014
11/24/2014
11/24/2014

11/24/2014
11/24/2014
11/24/2014

11/24/2014
11/24/2014
11/24/2014

11/24/2014
11/24/2014
11/24/2014

NOV 24 2014



LONG-TERM WATER TRANSFERS DRAFT EIS/EIR COMMENT SHEET



There are several options to provide written comments. You can provide your written comments by turning in this form at the public meeting. You may also e-mail your comments directly to bhubbard@usbr.gov with the subject line "Long-Term Water Transfers" or mail this form to the Bureau of Reclamation (mailing address is on the back of this card). Whatever method you choose, please note that all written comments must be received by **5:00 p.m. (Pacific Standard Time) on December 1, 2014.**

PLEASE PRINT CLEARLY. PLEASE NOTE THAT ALL COMMENTS BECOME PART OF THE PUBLIC RECORD.

Name: Peter Ratner

Organization (If applicable): _____

Address: 44 Dacy Ave Chico 95973

Phone: 530 345 4603 Fax: () _____

E-mail: peter.ratner@gmail.com

Date: 10/21/14

Comment: I am opposed to ANY water transfer to

Southern Cal ~~outlet~~ unless & until mandatory conservation
measures are adopted by the agencies wanting
the transfers.

1

In this current drought, it is irresponsible at the
least ~~to~~ to continue the use of water for
such non-sustainable ~~activities~~ uses as lawns,
golf courses & irrigating desert land for
farming.



LONG-TERM WATER TRANSFERS DRAFT EIS/EIR COMMENT SHEET



There are several options to provide written comments. You can provide your written comments by turning in this form at the public meeting. You may also e-mail your comments directly to bhubbard@usbr.gov with the subject line "Long-Term Water Transfers" or mail this form to the Bureau of Reclamation (mailing address is on the back of this card). Whatever method you choose, please note that all written comments must be received by **5:00 p.m. (Pacific Standard Time) on December 1, 2014.**

PLEASE PRINT CLEARLY. PLEASE NOTE THAT ALL COMMENTS BECOME PART OF THE PUBLIC RECORD.

Name: Edwin Roland McNitt

Organization (if applicable): Chico saddle heads

Address: POB #862 Chico CA 95927

Phone: () _____ Fax: () _____

E-mail: eddyroland70@gmail.com

Date: 20 Nov 14

Comment: Regarding EIS:

ES 4.1 Groundwater substitution: "Groundwater storage would fill slowly over time". UNACCEPTABLE

WORDING FOR EIS We need to know exactly how long...

Table 2.9 Proposed Mitigation "NONE" UNACCEPTABLE

I witnessed your d and pony show at Chico. The unaddressed elephant in the room, to which almost all comments were directed to, was the issue of regeneration, which was not calculated in EIS. Groundwater substitution is like inheriting a fortune and squandering it, living high on the hog until it's all gone and you're left in poverty. The wise person sets up that that fortune as a PUBLIC TRUST, so that it lasts all your life, and your children's and grandchildren's in perpetuity.

Northern California says no to water transfers, especially when you have NO DATA ON AQUIFER REGENERATION.



**UNITED STATES
POSTAL SERVICE**

Dear Postal Customer:

The enclosed has been damaged in handling in the Postal Service.

We realize that your mail is important to you and you have every right to expect it to be delivered intact and in good condition. The Postal Service makes every effort to properly handle the mail entrusted to it but, due to the large volume, occasional damage does occur.

When a Post Office handles in excess of 7 million pieces of mail daily, it is imperative that mechanical methods be used to maintain production and ensure prompt delivery of the mails. It is also a fact that modern production methods do not permit personal attention to individual pieces of mail. Damage can occur if mail is insecurely enveloped or bulky contents are enclosed. When this occurs and our machinery is jammed, it often causes damage to other mail that was properly prepared.

We are constantly striving to improve our processing methods to assure that an occurrence such as the enclosed



LONG-TERM WATER TRANSFERS DRAFT EIS/EIR COMMENT SHEET



There are several options to provide written comments. You can provide your written comments by turning in this form at the public meeting. You may also e-mail your comments directly to bhubbard@usbr.gov with the subject line "Long-Term Water Transfers" or mail this form to the Bureau of Reclamation (mailing address is on the back of this card). Whatever method you choose, please note that all written comments must be received by **5:00 p.m. (Pacific Standard Time) on December 1, 2014.**

PLEASE PRINT CLEARLY. PLEASE NOTE THAT ALL COMMENTS BECOME PART OF THE PUBLIC RECORD.

Name: Margaret Rader

Organization (If applicable): _____

Address: 1866 Bidwell Ave Chico

Phone: () _____ Fax: () _____

E-mail: mrader@pacbell.net

Date: 10/22/14

Comment: I am in full support of all comments made by members of the audience in Chico on Tues. 10/20/14.

I particularly agree with one gentleman who felt that the primary basis for long term water transfers is greed. The desire of a few to control our valuable water resources is beyond reason given the current drought situation (not previous drought history) in the Northern Sacramento Valley

Margaret Rader

Margaret Rader
1866 Bidwell Ave.
Chico, CA
95926

AQUA-266C



Long-Term Water Transfers Draft EIS/EIR
Brad Hubbard
Bureau of Reclamation
2800 Cottage Way, MP-410
Sacramento, CA 95825

9582531858 C015

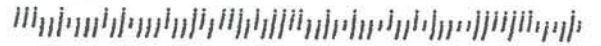

Please fold, staple, stamp, and mail.

OCT 24 2014

Buckman, Carolyn

From: Hubbard, Bradley <bhubbard@usbr.gov>
Sent: Friday, November 28, 2014 10:01 AM
To: Frances Mizuno; Buckman, Carolyn; Veronese, Gina
Subject: Fwd: Long-Term Water Transfers

Another comment email...

----- Forwarded message -----

From: Sherri Scott <sherri@grubchico.org>
Date: Fri, Nov 28, 2014 at 9:27 AM
Subject: Long-Term Water Transfers
To: bhubbard@usbr.gov

I would like to share my opposition to the taking or selling (“transfers”) of any water that affects my home and environs, being the North State, not from surface nor from ground sources. They are all intertwined as a whole ecosystem and it all affects me and my health, my livelihood, my thriving agricultural community, and the natural and diverse beauty of nature that brought me to this area. I represent many others who moved to this area for exactly the same reasons and your proposal threatens our way of life!

1

Currently I am witnessing a terrible die off of 50-100 year old trees on the farm. This is at a terrible loss of shade and habitat, but in economic terms that adds costs to summer cooling, high costs of employing tree work to prevent the loss of property as the trees fall or loose limbs, as well as the loss to property if the limbs escape maintenance.

2

Many farmers I know had to dig their well deeper this year and/or lost their pump due to a drop in the water. Our ag well that has gone dry each summer for the last 3 years for August, was dry before the summer even began this year. Fortunately we have been able to use a small domestic well as our back up. Regardless, each year knowing that our water supply could be compromised, we make conscious decisions on how much land we can farm and what types of crops can be managed with what we have. **This is responsible farming.** I refuse to allow folks who view water irresponsibly, relying on water needy crops and industries, to take the water that feeds me, my community, and my ecosystem.

3

I see all around me in neighborhoods and on hikes that plants and trees are dying. I rely on this shade cover to cool me in the summer. The trees rely on the water that its roots worked so hard over a long period of time to reach. The plants around them rely on the shade and water that the

trees provide. The animals, the insects, the birds, the mushrooms, the microorganisms and us humans all rely on this.

3

I hear repeated stories at the farmers market from customers who are witnessing the same things about the effects of drought: dead/dying trees, more insect pressure, more desperate invasions of their fenced off gardens by deer and other animals. They are noticing for the first time or higher occurrences of large predators desperately roaming into human populated areas to find food.

It is unconscionable to even suggest that the water removal in this water proposal will not affect us residents of the North State, us farmers, us nature lovers, us shade lovers! It is unconscionable to even suggest that the money and needs of the Westlands Water District are more important than those that fell in love with this area, moved here, laid their literal and figurative roots down, paid their taxes, and have no real say in actions that SEVERELY affect their way of life and in their livelihoods! It is ridiculous! It is atrocious! It is conniving! IT IS GREEDY!

4

Please stop this water grab!

~Sherri Scott

1525 Dayton Rd.

Chico, CA 95928

530-342-3376

--

Thanks,

Brad



LONG-TERM WATER TRANSFERS DRAFT EIS/EIR COMMENT SHEET



There are several options to provide written comments. You can provide your written comments by turning in this form at the public meeting. You may also e-mail your comments directly to bhubbard@usbr.gov with the subject line "Long-Term Water Transfers" or mail this form to the Bureau of Reclamation (mailing address is on the back of this card). Whatever method you choose, please note that all written comments must be received by **5:00 p.m. (Pacific Standard Time) on December 1, 2014.**

PLEASE PRINT CLEARLY. PLEASE NOTE THAT ALL COMMENTS BECOME PART OF THE PUBLIC RECORD.

Name: Amalie Sorensen Amalie Sorensen

Organization (If applicable): _____

Address: 1619 Arcadian Ave Chico CA 95926

Phone: 530-345-0201 Fax: () _____

E-mail: AMALIESORENSEN@comcast.net

Date: 10/27/14

Comment: We are farmers (my family) for generations - and generations to come (HOPEFULLY). We farm SUSTAINABLY.

We and outraged others will fight this criminal water-stealing legally. YOU greedy, Motherfuckin' weirdos can F*CK off and GO TO HELL if you're NOT there already.

Get a life, please! we could be friends in this but NOT by your tactics alone.

1



CA 957

AQUA-266C

30 OCT 2014 PM 3 L



Long-Term Water Transfers Draft EIS/EIR
Brad Hubbard
Bureau of Reclamation
2800 Cottage Way, MP-410
Sacramento, CA 95825

00000142000



Please fold, staple, stamp, and mail.



OCT 31 2014

Buckman, Carolyn

From: HUBBARD, BRADLEY <bhubbard@usbr.gov>
Sent: Friday, October 24, 2014 9:03 AM
To: Buckman, Carolyn; Frances Mizuno; RICHARD WOODLEY; Veronese, Gina; WILBERT MOORE
Subject: Fwd: Long term water transfers
Attachments: St. Amant background info.doc

----- Forwarded message -----

From: Tony St. Amant <tsainta@hotmail.com>
Date: Fri, Oct 24, 2014 at 8:00 AM
Subject: Long term water transfers
To: "Brad Hubbard (USBR)" <bhubbard@usbr.gov>
Cc: "Gary Bardini (DWR, DD IRWM)" <gary.bardini@water.ca.gov>, "Frances Mizuno (SLDMWA)" <frances.mizuno@sldmwa.org>, "Matt Weiser (Sacto Bee)" <mweiser@sacbee.com>, "Heather Hacking (Chico ER)" <hhacking@chicoer.com>, "Melissa Daugherty (Chico News & Review)" <melissad@newsreview.com>, "Andrew Creasy (Appeal Democrat)" <acreasey@appealdemocrat.com>, "Chip Thompson (Red Bluff Daily News)" <editor@redbluffdailynews.com>

For:

Brad Hubbard

Project Manager

Bureau of Reclamation

U.S. Department of Interior

Dear Mr. Hubbard,

Your agency and the San Luis & Delta-Mendota Water Authority held a hearing in Chico earlier this week on the public draft of the EIS/EIR for long-term water transfers. The EIS/EIR attempts to justify the transfer of between 360,000 and 600,00 acre feet of water per year for ten years from sellers upstream of the Delta to water users south of the Delta and in the San Francisco Bay Area.

However, a critical fact came out during the hearing. The data for EIS/EIR's hydrologic analysis is based on the period 1970-2003. None of the climatologic or hydrologic reality the state has experienced since that time is included: none of the increasing evidence that we are actually in a period of climate change and none of the

clear, decade-long trends in groundwater declines seen in an increasing number of areas in the Northern Sacramento Valley.

2

The excuse offered by Carrie Buckman of CDM Smith, your consultant, was that the chosen water model is not up to date. The unanswered questions would be, “Why was an out-of-date model chosen?” And, as this analysis has been planned since at least late-2010 and modeling shortcomings have been known for at least those four years, if none is available, “Why hasn’t an up to date model been developed to fulfill this need that has been identified as critical to a large portion of California agriculture?” If the cost of a transfer program includes the need for an up-to-date model, then the proponent should be responsible for developing that model and validating it through a rigorous peer review process. Choosing an out-of-date model should not be an allowable choice.

3

I can see how SLDMWA would be pleased with hydrologic data that ended in 2003, but I don’t understand how your agency could support such an analytic shortcoming. It would seem to me that, as a federal agency, the Bureau would have a balanced responsibility between the welfare of water source areas north of the Sacramento Delta and water consumption areas south of the Delta. Your agency’s support of this terribly flawed analysis results in an inappropriate bias in support of the agencies that wish to import water to compensate for their decades long indifference to sustainable water supplies.

I urge the Bureau to withdraw the EIS/EIR until it is supported by up-to-date hydrologic and climatologic data analyzed through a vigorously peer-reviewed model.

Sincerely,

Tony St. Amant

Chico

--

Thanks,

Brad

Tony St. Amant

tsainta@hotmail.com, telephone (530) 332-9116

Local and Regional Public Policy Experience

Participant in most local and regional water forums from 1999 – present.

Public participant in developing the statewide Strategic Plan for Integrated Regional Water Management.

Public participant in the California Water Plan update 2013.

Public participant at most Northern Sacramento Valley Integrated Water Management Plan Board, Technical Advisory Committee, and public outreach meetings from January 2011 through December 2012.

Public participant in the Butte County general plan update from March 2007 through adoption in October 2010. Successfully advocated for inclusion of a water element.

Member of the initial Integrated Watershed Stakeholders' Group, the public advisory body for development of the Butte County Basin Management Objectives ordinance (Chapter 33A).

Public participant in development of the Butte County Groundwater Conservation ordinance (Chapter 33).

Butte County Deputy Chief Administrative Officer 1991-94, 2000-01

Provided staff support to the Butte County Water Commission, 1991-1994 (prior to establishment of the Water and Resource Conservation Department).

Budget and policy analyst for numerous county departments.

Prior Public Policy Experience

U.S. Air Force, 1957-1987

Retired as Director for Strategic Analysis at the Air Force Center for Studies and Analyses, Washington, D.C.

Education

Master's degree in Political Science, CSU Chico, California, 1991.

Bachelor's degree in Social Science, Troy State University, Alabama, 1973.

November 3, 2014

To: Brad Hubbard (USBR)
Frances Mizuno (SLDMWA)

Subject: Comment 1, Tony St. Amant, Long-Term Water Transfers Environmental Impact Statement/Environmental Impact Report, September 2014

Issue: The San Luis & Delta-Mendota Water Authority is inappropriate as a lead agency for the Long-Term Water Transfers Environmental Impact Statement/Environmental Impact Report, September 2014.

Summary: The San Luis & Delta-Mendota Water Authority (SLDMWA) does not meet California Environmental Quality Act (CEQA) requirements to be the lead agency for this EIR, and there is an unmitigable conflict of interest inherent with SLDMWA as the sole lead agency.

Recommendation:

The EIS/EIR should be withdrawn from public circulation; and

The lead agency should be changed to:

An appropriate state agency with SLDMWA and the counties that overlie the DWR Bulletin 118 groundwater basins and confined (deeper) aquifers from which groundwater substitution transfers may occur designated as responsible agencies; or

A group of agencies, including SLDMWA and the counties that overlie the DWR Bulletin 118 groundwater basins and confined (deeper) aquifers from which groundwater substitution transfers may occur, organized into a cooperative effort by contract, joint exercise of powers, or similar device¹.

Discussion:

1. SLDMWA does not meet CEQA requirements to be the lead agency.

SLDMWA is a joint powers public agency that encompasses approximately 2.1 million acres of 29 water service contractors within the western San Joaquin Valley and San Benito and Santa Clara counties. Its boundaries are coextensive with those of its members². All of SLDMWA's purposes and powers are centered on providing benefit to member organizations.³

¹ 14 CCR § 15051 (d).

² Amended and Restated Joint Exercise of Powers Agreement (SLDMWA JPA), San Luis & Delta-Mendota Water Authority, January 1, 1992, para. 3, pg. 4.

³ SLDMWA JPA, para. 6, pp. 4-7.

SLDMWA is a narrowly purposed regional organization, yet it is designated as the lead—and therefore, certifying—agency for this EIS/EIR, which has the potential to impact the long-term water supplies and environment of a number of California counties well removed from its geographical boundaries. This relationship does not comply with CEQA or Title 14, California Code of Regulations, nor does it recognize provisions of the Sustainable Groundwater Management Act.

CEQA § 21067 defines a lead agency as the public agency that has the principal responsibility for carrying out or approving a project which may have a significant effect on the environment. SLDMWA represents only half of the long-term water transfer process—the potential buyers. The other half—the potential sellers—is comprised of 29 independent agencies⁴, none of which are designated even as responsible agencies in accordance with CEQA § 21069.

14 CCR § 15051 (b)(1) , confirms SLDMWA as an inappropriate organization to be the lead agency: “The Lead Agency will normally be the agency with general governmental powers, such as a city or county, rather than an agency with a single or limited purpose”

Beyond the environmentally-oriented requirements of CEQA and Title 14, the process should integrate the legislative intent of the Sustainable Groundwater Management Act, which among other things is to recognize and preserve the authority of cities and counties to manage groundwater pursuant to their police powers⁵ and that water transfers must respect applicable city and county ordinances⁶. SLDMWA is not the appropriate agency to be certifying findings that may relate to those authorities outside of its own boundaries.

With SLDMWA as lead agency and no potential sellers or source counties designated as responsible agencies, the process is unreasonably biased toward the narrow functional interests of SLDMWA and its joint agencies.

Potential sellers and source counties need to be authoritatively involved in any EIS/EIR certification process that holds the potential for long-term effects on their groundwater sustainability, as does this one. The ability to submit comments for *consideration* by SLDMWA and USBR falls far short of a valid, balanced process.

2. There is an inherent and unmitigable conflict of interest with SLDMWA as the lead agency.

Common law doctrine requires a public officer to exercise his or her powers with disinterested skill and primarily for the benefit of the public. Actual injury is not required. A public officer is barred from putting himself in a position in which he may be tempted by his own private interests to disregard his principals and the interests of others.⁷

⁴ Long-Term Water Transfers Public Draft EIS/EIR, September 2014, Table ES-2.

⁵ Sustainable Groundwater Management Act, Uncodified Findings (b)(5).

⁶ Sustainable Groundwater Management Act, § 10726.4, (a)(3).

⁷ Conflicts of Interest, Office of the Attorney General, 2010, para. B, pg. 102.

The structure of the unmitigable conflict of interest is embodied in three classes of interests which ought to be on equal ground in the water transfer EIS/EIR process but which are not:

Class 1: Willing buyers, represented by the EIS/EIR lead agency SLDMWA

The willing buyers of transferred water, some or all of the 29 members of the SLDMWA joint powers agreement, are at risk of suffering serious financial losses if they are unable to import water from other areas of the state over the next 10 years. Per its joint powers responsibilities, SLDMWA is obligated to act in the interests of, and for the benefit of, member agencies. Consequently it would be a breach of fiduciary responsibility for SLDMWA to act for the benefit of any other organization at the expense of its joint powers partners. SLDMWA is obligated to seek as much water as its member agencies need from source areas without regard for the economic or environmental impact on those areas. Yet the final EIS/EIR will reflect SLDMWA's *independent judgment and analysis*⁸, with no requirement to incorporate any concerns of source area public agencies, groundwater-dependent entities, or groundwater-dependent individuals.

Class 2: Willing sellers, unrepresented in the EIS/EIR process and representing no one in the source areas but their own individual single-purpose organizations

Willing sellers have no standing in the EIS/EIR. While their actions are integral to execution of the proposed water transfers, they were not accorded Responsible Agency status as seems to be indicated by CEQA § 21069. But even if they had been accorded Responsible Agency status, that status would have put their interests in conflict with the third class of interests, groundwater users in the source areas who are not willing sellers. This conflict exists in the northern Sacramento Valley because the willing sellers share water basins with other groundwater users as described below.

The core of this conflict is that willing sellers stand to gain revenue from their sales while those who do not sell—and have no standing in the selling process—stand to incur expenses as water levels decrease from groundwater substitution transfers because of their need to deepen wells and/or drill new wells.

Class 3: Groundwater users in the source areas who are not willing sellers, but who share their groundwater sources (basins) with willing sellers

Groundwater users in the northern Sacramento Valley who are not willing sellers of transfer water are groundwater-dependent cities and towns, groundwater-dependent rural homeowners, and groundwater-dependent agriculturalists. They are a large majority of the population in the northern Sacramento Valley in comparison to the estimated two percent of the population who comprise the potential sellers. This class stands to incur expenses as water levels decrease because of the need to deepen wells and/or drill new wells in response to lowered groundwater levels that will result from groundwater substitution water transfers. Their appropriate representation would be counties, which also hold statutory authority over ground water, but counties have not been accorded agency status in the process.

⁸ 14 CCR 15090 (a)(3)

If SLDMWA is a public agency, conflict of interest constraints must disqualify it from its role as sole lead agency for the long-term water transfer EIR. If SLDMWA is not a public agency, it is not eligible to be the lead agency⁹.

Conflicts of interest abound in the project and in the EIS/EIR, all of which should have been recognized during the scoping process four years ago. The fact they were not could be interpreted as a confirmation of biases that went into developing the project and producing the draft EIS/EIR. The time-frame for moving the water transfer project forward is critical, but SLDMWA's and USBR's failures to properly plan and coordinate this project over the past four-plus years should not be accepted as a valid reason to override the interests of source area organizations and citizens.

SLDMWA's and USBR's failure to integrate agencies into the EIS/EIR effort in a way that balances obvious and well known conflicting interests, whether caused by administrative oversight or bias, cannot be allowed to stand. The stakes for long-term water sustainability in the northern Sacramento Valley are just too high.

4

⁹ CEQA § 21067: "Lead agency' means the public agency which has the principal responsibility for carrying out or approving a project which may have a significant effect upon the environment."

Buckman, Carolyn

From: Hubbard, Bradley <bhubbard@usbr.gov>
Sent: Monday, December 01, 2014 4:27 PM
To: Buckman, Carolyn; Veronese, Gina; Frances Mizuno
Subject: Fwd: Long-Term Water Transfers

Comment email.

----- Forwarded message -----

From: karen stinson <jcdlove123@gmail.com>
Date: Mon, Dec 1, 2014 at 4:00 PM
Subject: Long-Term Water Transfers
To: bhubbard@usbr.gov

Dear Mr Hubbard,

I attended the EIS/Eir Public Meeting in Chico on October 15, 2014. I am writing to you today to show my support for my community and for the natural resources we are so blessed with here in Butte County. I am writing to urge you to have more research done on the long term effects of transferring water from the Sacramento River and from the Tuscan Aquifer. In these times of out of control climate change and extreme weather conditions, I urge you to error on the side of caution when it concerns our water.

1

Thank You, and God Bless

Karen Stinson
Chico, CA

--
Thanks,

Brad

Buckman, Carolyn

From: HUBBARD, BRADLEY <bhubbard@usbr.gov>
Sent: Thursday, October 23, 2014 4:09 PM
To: Buckman, Carolyn; Veronese, Gina; Frances Mizuno
Subject: Fwd: Long-Term Water Transfers

----- Forwarded message -----

From: Paula Sunn <paulasunn@gmail.com>
Date: Thu, Oct 23, 2014 at 3:52 PM
Subject: Long-Term Water Transfers
To: bhubbard@usbr.gov

Dear Mr. Hubbard,

I live north of the Delta and am very concerned at the water transfers that have been occurring on a temporary basis and even more so about the EIS/EIR that would facilitate longer term water transfers.

Historically, in California, areas with less population, but with adequate water supplies have been exploited in order to keep the dryer, desert areas of the state from having to make the difficult decisions about whether current land use patterns are sustainable, regardless of the environmental and economic degradation that occurs in the areas of origin. The Owens Valley is a good example of this.

1

The EIS/EIR is flawed in not having a way to take into account that the data used to draw conclusions is outdated and that there are already problems occurring in the north state due to the ongoing drought, exacerbated by the transfers that are happening now. In short, there is no evidence that there will be future water supplies that will be sufficient to maintain the current patterns of usage in the areas of origin, much less enough to transfer water south to sustain agriculture in areas that have already overexploited their supplies, especially during the dryer periods that the EIS/EIR is intended to cover.

2

It strikes me that economic interests of those served by the San Luis & Delta-Mendota Water Authority as well as those in the areas of origin who have surface water rights to sell, while replacing this water with further groundwater pumping, ignores the long term ecological degradation that will occur as well as the populations in the north that rely on these supplies. Economic gain for a few is not what should be driving decisions made about resources relied upon by many.

3

I urge you to not only reject this current EIS/EIR, but to do what you can to stop the current temporary water transfers.

Respectfully,

Paula Sunn
5613 Glen Way, Paradise, CA 95969
(530) 514-1584

--
Thanks,

Brad



LONG-TERM WATER TRANSFERS DRAFT EIS/EIR COMMENT SHEET



There are several options to provide written comments. You can provide your written comments by turning in this form at the public meeting. You may also e-mail your comments directly to bhubbard@usbr.gov with the subject line "Long-Term Water Transfers" or mail this form to the Bureau of Reclamation (mailing address is on the back of this card). Whatever method you choose, please note that all written comments must be received by **5:00 p.m. (Pacific Standard Time) on December 1, 2014.**

PLEASE PRINT CLEARLY. PLEASE NOTE THAT ALL COMMENTS BECOME PART OF THE PUBLIC RECORD.

Name: Melinda Teves

Organization (If applicable): _____

Address: 1066 E. 8th St., Chico CA 95928

Phone: () _____ Fax: () _____

E-mail: _____

Date: 10/21/14

Comment: _____

- No on groundwater substitution transfers

- No on putting these decisions in the hands of buyers and sellers with self-interest in mind

- No on implementing water transfers prior to localities taking over groundwater decisions per recent legislation

- No on formulating plans based on data before 2004.

- No on these proposed water transfers

1

2

3

Mrs. Sally Wallace
167 Mandalay Court
Chico, CA. 95973

October 24,2014

Long Term Water Transfers
Brad Hubbard
Bureau of Reclamation
2800 Cottage Way MP 410
Sacramento, CA. 95825

Dear Sir”

Everyone I know in Northern California, just about, is violently opposed to this Water Transfer. It is inconceivable that you would not only allow it but instigate it. One bad drought year, and this is the worst we have had in years, is not a good enough reason to send our water to Southern California. You might suggest they start desaliation projects on ocean water, instead.

1

2

Another solution is more careful watering by the farmers... in the central and southern parts of the state..they have been rather profligate with water use over the years.

3

Most of all, we have to leave enough water in streams and rivers and forests for the wildlife... #1 priority, or should be.

4

At the very least, postpone the dams and transfers to the future... it's starting to rain, give nature a chance and don;t make panic decisions.

Respectfully

Mrs Sally Wallace
Mrs. S.M. Wallace

Mrs. Sally Wallace
163 Mendocino Court
Orinda, CA 94553

OCT 27 2014

October 14, 2014

Long Term Water Treatment
Burt Hubbard
Director of Administration
California Water Service
Sacramento, CA 95833

Dear Sir,
I've only known Northern California just about as well as you would
opposed to this Water Treatment. It is inconceivable that you would
and only allow it but instead it. One bad drought year and this is
the worst we've had in years. It's not a good enough reason to
send our water to Southern California. You might suggest they
and desalination projects on ocean water instead.

Another solution is more carefully watered by the farmers... in the
central and northern parts of the state they have been cutting
droughts with water use over the years.

...the priority should be
All the very least response the dams and transfers to the future...
the starting to give water a chance and don't make plans
decision.

Respectfully,
Mrs. S.M. Wallace

Buckman, Carolyn

From: Hubbard, Bradley <bhubbard@usbr.gov>
Sent: Friday, November 28, 2014 9:10 AM
To: Frances Mizuno; Buckman, Carolyn; Veronese, Gina
Subject: Fwd: Long-term water transfers

----- Forwarded message -----

From: **Suzette Welch** <booksontape@rocketmail.com>
 Date: Thu, Nov 27, 2014 at 8:20 AM
 Subject: Long-term water transfers
 To: "bhubbard@usbr.gov" <bhubbard@usbr.gov>

I urge you not to move forward with the proposed water transfers to San Luis and Delta Mendota Water Authority. I am in opposition to the timing of the water transfers “especially in periods of drought” and the size of the proposed water transfers which will allow water to be bought in northern California then sold to a desert area in Central California - the San Luis and Delta Mendota Water Authority. 1

The area to receive transfers of water from Northern California is a desert. They have ruined their aquifer by over pumping and now have subsidence so there is less underground space to store water the groundwater that they do get. What should be done in the South Central Valley is planting of annual crops in years when they have enough water in the area to allow these crops. Instead trees were planted there so that farmers could show that they needed water every year. Now these Southern factory farmers want us to ship water south. We have need of our water in Northern California to support our many family farms. We especially need to keep all the water possible in years like this year where there is not enough water due to a four year drought. 2
3

There is a big fallacy in your report. The hydrologic period analyzed in the EIS/EIR is from 1970-2003, neglecting the last 11 years because the model wasn't up-to-date. Thus the analysis doesn't take into account the current drought. 4

How can you say in your EIR that there will be no environmental impact on the area of origin of the water when there are already wells drying up in this area due to over pumping.

We have wells going dry right now in the foothills and in North and South Chico. People here don't have water to drink and you propose to take more surface water from willing sellers. These sellers are people with water rights and are just out to make money no matter the cost to the land. They sell the surface water and then they pump water out of the aquifer taking needed water from others and making the shallower wells run dry. Pumping the aquifer will drop the depth of water in the water table which will result in loss of our ecosystem. Our beautiful meadows and oak forests will die from lack of water. You will turn another part of California into a desert like the Owens Valley.

5

Suzette Welch
13 Hilda Way
Chico, Ca. 95926

--
Thanks,

Brad

Buckman, Carolyn

From: Frances Mizuno <frances.mizuno@sldmwa.org>
Sent: Monday, December 01, 2014 12:33 PM
To: Hubbard, Bradley; Buckman, Carolyn; Veronese, Gina
Subject: Comment Letter

[One more comment letter.](#)

From: Seamus Yeo [mailto:seamus22hk@gmail.com]
Sent: Monday, December 01, 2014 12:11 PM
To: Frances Mizuno
Cc: bwright@friendsoftheriver.org
Subject:

1893 Garden Ave, Apt 7
Eugene, Oregon, 97403
Nov 5th, 2014
Seamus Yeo

Frances Mizuno
San Luis & Delta-Mendota Water Authority
842 6th St, Los Banos CA 93635
Phone: (209) 832-6200
Email: frances.mizuno@sldmwa.org

Dear Mr Mizuno,

I am writing regarding to your recent proposal for the Long Term Water Transfer, that was uploaded to the Environmental Impact Assessment government website on September 2014. I will be doing as part of a course assignment to review the Public Draft of the Environmental Impact Assessment.

The introductions and proposed actions are well informed in terms of history of the area, location and the different lakes that could be involved, service provided and companies that are involved. However, the lack of explanation on what the current infrastructure of CVP and what method would be used to transfer water from the seller to the buyer. The cost of maintenance of the 10 year period would be questioned and should be mentioned.

1

In each of the environmental aspect of this project will be assessed in the following paragraphs respectively; Water, Geology and Soil; Air Quality; Climate Change; Flood Control; Cumulative Effects.

In the assessment of Water, it has been well written for understanding the quality and quantity of supply and the water. Through the use of laws, regulations and information on each lake which water will be extracted, it has given a good over all look. However, the lack of details of each total capacity of water and how much water will used during the transfer is questionable. The only information given was how much water could be extracted but no relation to the overall total amount of water.

2

In the Geology and soil, they have provided many different topography of maps regarding to the soil that are present around California, along with the different method of translocation of various soils. It would be good if you can provide a 3D infrastructure of the current CVP, and the area that they have been built on.

3

In Air Quality the data provided for different compounds, in direct impact of Carbon dioxide in water is noted and each different method of transferring water is noted. The cumulative effects are also noted well, there is no need for additional information.

4

In Climate Change, it is well written that the most direct issues are affecting the transfer. However, the indirect to animals and soil is a rather difficult to research in. Note that monitoring the possibility of invasive species invading upstream is a plausible situation, which is not noted in Cumulative effects. If there is an Accelerated erosion doing storm water, would it not also accumulate possible sediments that would damage flood control.

5

In the Flood control, the information provided is well responded and the mitigation and the acceptance of some area unable to endure flood possibility should be taken into account. However, the flood control also holds some of the key factors into the methane hold possible harm to the environment especially animals that could not survive in acidic environments.

6

This Draft Environmental Impact Assessment would provide a useful tool as it cover many aspects of environmental concern which will help the community in decision and project managers to decide. However, it could use a little more information about the water supply as ecologist and many other scientist in that field may question how much water is “sustainable”. You have only stated how much water could be taken out, without having mentioning the total amount of water that is current there.

7

Overall, I would like to say that in general that the draft environmental statement is well researched and very informative. I would like that if you can add additional material on a more local levels, as it would affect them the most and their knowledge from experience would affect the overall projects and the cost of maintenance over the 10 years and a timeline. In addition, I would like you to add additional information on monitoring as climate change on the over all levels of water and geology and soil, as those two would inhibit many of the long term water transfer and possible damage in the future.

Yours Faithfully
Seamus Yeo
Student, University of Oregon.

Meeting Notes

11/24/2014

Dear Mr. Brad Hubbard:

I am strongly against the USBR proposal to facilitate the transfer of Sacramento Valley water (mainly by conjunctive use) to south of the Delta and San Francisco Bay water districts.

Several glaring lapses in the proposal stand out. Limiting the baseline years to 1973 to 2003 avoids the last decade of climate change effects and our severe, prolonged current drought.

In recent years the Sacramento Valley general water table has significantly dropped with accompanying ground subsidence.

Residential and agriculture wells have gone dry. And the proposed water transfer will occur during drought and severe drought years - just when the immediate and long term harm to our river, streams and aquifer would be the greatest.

The USBR suggestion that water tables will generally reconstitute in the future is completely unsubstantiated.

No consideration of the accumulative effects on the watershed ecology is included in the USBR analysis.

No significant long-term economic analysis is evident comparing the transient benefit to the Westlands Water District versus the destruction of the Northern California Water shed - the source of 60-70% of California water.

Please put science above political and lobbying pressure to preserve the Sacramento Valley Watershed - Thank you

JULIAN ZENER MD

JULIAN ZENER
1021 N. CHERY ST.
CHICO, CA. 95926

JULIANZENER@COMCAST.NET

MSCME
in Jacksonville, Fla.
(800) 462-9633 (USA only)
(904) 953-7114
Fax: (904) 953-2954
E-mail: cme-jax@mayo.edu

MSCME
in Rochester, Minn.
(800) 323-2688 (USA only)
(507) 284-2509
Fax: (507) 284-0532
E-mail: cme@mayo.edu

MSCME
in Scottsdale, Ariz.
(480) 301-4580
Fax: (480) 301-8323
E-mail: mcs.cme@mayo.edu



LONG-TERM WATER TRANSFERS DRAFT EIS/EIR COMMENT SHEET



There are several options to provide written comments. You can provide your written comments by turning in this form at the public meeting. You may also e-mail your comments directly to bhubbard@usbr.gov with the subject line "Long-Term Water Transfers" or mail this form to the Bureau of Reclamation (mailing address is on the back of this card). Whatever method you choose, please note that all written comments must be received by **5:00 p.m. (Pacific Standard Time) on December 1, 2014.**

PLEASE PRINT CLEARLY. PLEASE NOTE THAT ALL COMMENTS BECOME PART OF THE PUBLIC RECORD.

Name: JOHN SCOTT

Organization (If applicable): BUTTE VALLEY COALITION

Address: 4370 TAO WAY, BUTTE VALLEY, CA 95965-8345

Phone: (530-533-8394) Fax: ()

E-mail: john_lewis_scott@msn.com

Date: November 30, 2014

Comment:

This EIS/R must be withdrawn, because it is totally inadequate as any EIR/EIS could ever be.

1

Follow the comments of the Butte Environmental Council. Your EIS/EIR is so bad that I feel I need to protect and maintain my legal rights in this matter.

2

Very Sincerely,

John Scott - individually and with the Butte Valley Coalition,

Place
First Class
Stamp
Here

Long-Term Water Transfers Draft EIS/EIR
Brad Hubbard
Bureau of Reclamation
2800 Cottage Way, MP-410
Sacramento, CA 95825

Please fold, staple, stamp, and mail.

BUREAU OF RECLAMATION
MP-REGION
2014 DEC -1 PM 11:22

Nov-30, 2014

JOHN SCOTT

BUTTE VALLEY COALITION



Butte Environmental Council

Educating and advocating for the land, air, and water in Northern California since 1975



BUTTE-SUTTER BASIN AREA GROUNDWATER USERS



December 1, 2014

Brad Hubbard (USBR)
Frances Mizuno (SLDMWA)

We support the entire
12 page document submitted
by the Butte Environmental Council.
John Scott
advocate

Subject: Comments, Long-Term Water Transfers (LTWT) Environmental Impact Statement/Environmental Impact Report (EIS/R), September 2014

Butte Environmental Council (BEC) and the undersigned groups and individuals submit the following comments concerning Long-Term Water Transfers. The comments focus on the legal issues surrounding groundwater substitution water transfers and the technical deficiencies of the EIS/R. Concerned citizens of the northern Sacramento Valley recognize that it is long past the time needed to realize the limitations and variability of our natural water supply. We must learn to live within the confines of that system and stop the exploitation of groundwater and strive to improve protections of this critical, fail-safe source of life.

BEC's policy statement regarding water identifies our concerns for Northern Sacramento Valley water resources. Specifically, we believe that citizens should have control over local resources; that Northern California's watersheds must be protected for future generations; and that its ground and surface water must not be exported out of the area to address misuse, waste, and over-allocation. The undersigned groups and individuals submit these comments holding to one conviction:

The EIS/R should be withdrawn from public circulation until the issues listed herein can be adequately addressed.

Page 1 of 12
— pages 2 thru 11 are on file —

Comments LTWT EIS/R Public Draft, September 2014

e. Water quality

The environmental assessment surrounding the LTWT completely ignores groundwater quality issues. There are numerous plumes throughout the Sacramento Valley for which the Department of Toxic Substance Control has oversight.

Conclusion

The EIS/R should be withdrawn from public circulation; and

The EIS/R should be modified to:

Reflect the elements and requirements of a programmatic EIS/R, strictly adhering to page limitations and tiering of appropriate project level environmental documentation; and

Reflect a legally appropriate lead agency, such as a group of agencies, including SLDMWA and the counties that overlie the DWR Bulletin 118 groundwater basins and confined (deeper) aquifers from which groundwater substitution transfers may occur, organized into a cooperative effort by contract, joint exercise of powers, or similar device.⁶

Sincerely,



Robyn Difalco
Executive Director
Butte Environmental Council

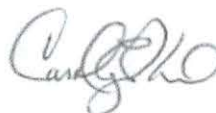

Carol Perkins
Water Policy Advocate
Butte Environmental Council



JOHN SCOTT

BUTTE VALLEY COALITION

BUTTE COUNTY, CA

⁶ 14 CCR § 15051 (d).



LONG-TERM WATER TRANSFERS DRAFT EIS/EIR COMMENT SHEET



There are several options to provide written comments. You can provide your written comments by turning in this form at the public meeting. You may also e-mail your comments directly to bhubbard@usbr.gov with the subject line "Long-Term Water Transfers" or mail this form to the Bureau of Reclamation (mailing address is on the back of this card). Whatever method you choose, please note that all written comments must be received by **5:00 p.m. (Pacific Standard Time) on December 1, 2014.**

PLEASE PRINT CLEARLY. PLEASE NOTE THAT ALL COMMENTS BECOME PART OF THE PUBLIC RECORD.

Name: JOHN LEWIS SCOTT

Organization (If applicable): BUTTE VALLEY COALITION

Address: 4370 TAO WAY, BUTTE VALLEY, CA 95965-8345

Phone: (530) 533-8394 Fax: () _____

E-mail: john_lewis_scott@MSA.COM

Date: Nov 30, 2014

Comment: _____

I support THE ENTIRE "12 PAGE COMMENTS"
SUBMITTED BY THE BUTTE ENVIRONMENTAL COUNCIL,
CITCO, CALIFORNIA; DATED DECEMBER 1, 2014.

VERY SINCERELY,

John Scott

JOHN SCOTT

PS: Please keep me current on future aspects of
this and all long or short term water transfers
from north of the Sacramento Delta.

John & Sue Scott
4370 Tao Way
Butte Valley, CA 95965

SACRAMENTO CA 95877
01 DEC 2014 PM 6 L

AQUA-266C



Long-Term Water Transfers Draft EIS/EIR
Brad Hubbard
Bureau of Reclamation
2800 Cottage Way, MP-410
Sacramento, CA 95825

958251898003

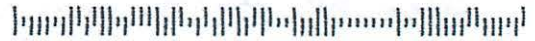

Please fold, staple, stamp, and mail.



2014 DEC -1 PM 4:18
BUREAU OF RECLAMATION
MP-REGION

Appendix P

EIS/EIR Distribution List

This appendix includes the distribution list for the Final Environmental Impact Statement/Environmental Impact Report (EIS/EIR). Only names and affiliations, if applicable, are shown on this list. This list has been in development since the Notice of Intent and scoping meetings in 2011.¹

The Final EIS/EIR is available at
http://www.usbr.gov/mp/nepa/nepa_projdetails.cfm?Project_ID=18361.

Copies of the Final EIS/EIR are available for public review at the following locations:

(1) Bureau of Reclamation, Mid-Pacific Region, Regional Library, 2800 Cottage Way, Sacramento, CA 95825,

(2) Natural Resources Library, U.S. Department of the Interior, 1849 C Street NW, Main Interior Building, Washington, DC 20240-0001, and

(3) San Luis & Delta-Mendota Water Authority (SLDMWA), 842 6th Street, Los Banos, CA 93635.

The distribution list includes the following:

- Representatives from participating buyers and sellers.
- Representatives from other Federal, State, and local agencies that commented or expressed interest in the project.
- Representatives from non-governmental organizations that attended public meetings, provided comments, or expressed interest in the project.
- Interested members of the public that attended public meetings, provided comments, or expressed interest in the project.

¹ Reclamation and SLDMWA used scoping meeting and public hearing sign in sheets to help develop the distribution list. Some individuals that signed in did not provide email addresses or the handwriting was illegible. If a name or email address was missed, Reclamation and SLDMWA have made the EIS/EIR available at identified locations and on Reclamation's website listed above.

P.1 Buyers and Sellers

Table P-1. Buyers and Sellers Distribution List

Name	Agency
Al Montna	Garden Highway Mutual Water Company
Andrea Clark	Downey Brand
Andrew Hitchings	Somach, Simmons, Dunn
Benjamin Bray	East Bay Municipal Utility District
Bradley Arnold	South Sutter Water District
Brett Ewart	City of Sacramento
Brett Gray	Natomas Central Mutual Water Company
Brett Scheidel	Pleasant Grove-Verona Mutual Water Company
Bryan Busch	Reclamation District 108
Christy Chung	Santa Clara Valley Water District
Dan Sherry	City of Sacramento
Dan York	Sacramento Suburban Water District
Daniel Griffith	Sycamore Mutual Water Company
Darren Cordova	MBK Engineers
Dave Underwood	Sacramento County Water Agency
David and Alice Te Velde Revocable Family Trust	Te Velde Revocable Trust
David Guy	Nor Cal Water Association
Dee Swearingen	Natomas Central Mutual Water Company
Dennis Falaschi	Pacheco Water District, Panoche Water District
Devin Mody	Santa Clara Valley Water District
Dustin Cooper	Anderson-Cottonwood Irrigation District, Butte Water District, Cordua Irrigation District
Edward Formosa	Sacramento Suburban Water District
Einar Maisch	Placer County Water Agency
Frances Mizuno	SLDMWA
Garth Hall	East Bay Municipal Utility District
Geoff Rabone	Merced Irrigation District
H.E. Niederberger, Jr.	Sacramento County Water Agency
Jan Lee	East Bay Municipal Utility District
Jeff Cattaneo	San Benito County Water District
Jeff Quimby	Contra Costa Water District
John Bennett	Eagle Field Water District
John Brennan	Goose Club Farms, Tule Basin Farms
John Sweigard	Merced Irrigation District
Jose Gutierrez	Westlands Water District
Kerry Schmitz	Sacramento County Water Agency
Leah Orloff	Contra Costa Water District
Lewis Bair	Reclamation District 108
Lucinda Shih	Contra Costa Water District
Marc Van Camp	MBK Engineers
Marcos Hedrick	Mercy Springs Water District
Mark Orme	Butte Water District
Martin McIntyre	San Luis Water District

Name	Agency
Marty Stripling	River Garden Farms
Max Sakato	Sutter Mutual Water Company
Mike Hardesty	Reclamation District 2068
Mike Tognolini	East Bay Municipal Utility District
Nicole Van Vleck	Garden Highway Mutual Water Company
Nicoli Nicholas	Pleasant Grove-Verona Mutual Water Company
Phil McMurray	Merced Irrigation District
Robert Roscoe	Sacramento Suburban Water District
Ryan Fong	Conaway Preservation Group
Scott Morris	Placer County Water Agency
Scott Tucker	Pelger Mutual Water Company
Stan Wangberg	Anderson-Cottonwood Irrigation District
Steve Bayley	City of Tracy
Steve Fausone	Laguna Water District
Steve Gidaro	Cranmore Farms
Steven Sloan	Oro Loma Water District
Thad Bettner	Glenn-Colusa Irrigation District
Todd Manley	Nor Cal Water Association (NCWA)
Tom Birmingham	Broadview Water District, Westlands Water District
Tom Glover	Westlands Water District
Water Cotter	Browns Valley Irrigation District

P.2 Federal, State and Local Agencies

Table P-2. Federal, State, and Local Agencies Distribution List

Name	Agency
Barbara Sachs	Reclamation District 1004
Bill Skinner	City of Coalinga
Bobby Pierce	West Stanislaus Irrigation District
Brad Matson	Richvale Irrigation District
Brendan Vieg	City of Chico
Candace Williams	Thomes Creek Water District
Carrie Rohr	Proberta Water District
Charles Orwick	Ash Creek Watershed, Battle Creek Watershed
Cindy Messer	Delta Stewardship Council
Curt Aikens	Yuba County Water Agency
Dale Melville	Dudley Ridge Water District
Dan Peterson	Sutter County
Daniel Ruiz	Maxwell Irrigation District, Meridian Farms
Danny Wade	Tranquility Irrigation District
David Coxey	Bella Vista Water District
David Luker	Desert Water Authority
David Weisenberger	Banta Carbona Irrigation District
Dennis Bentz	Kirkwood Water District
Dennis Westcot	San Joaquin River Group Authority
Diane Riddle	State Water Resources Control Board

Long-Term Water Transfers
Final EIS/EIR

Name	Agency
Don Ridenhour	Napa County Flood Control and Water Conservation District
Donita Hendrix	Dunnigan Water District
Doug Headrick	San Bernardino Valley Municipal Water District
Doug Teeter	Butte County Board of Supervisors
Ed Kriz	City of Roseville
e-PUR	South Delta Water Agency, Central Delta Water Agency
Eric Chapman	State Water Contractors
Eric Wedemeyer	Shasta County
Erick H Johnson	The Water Agency, Inc
Ernie Ohlin	Tehama County
Frank Apgar	Kings County
Fritz Grimmer	Cortina Water District
Garwin Yip	National Oceanic Atmospheric Association (NOAA)
Gina Darin	California Department of Water Resources (DWR)
Glenn Mathis	4M Water District
Greg Norby	City of Redding
Guillermo Santillan	Meridian Farms
Helen Birss	California Department of Fish and Wildlife (CDFW)
Jaime Traynham	Davis Water District
James D. Hartley	Avenal State Prison
James Lowden	Corning Water District
James M. Beck	Kern County Water Agency
Jane Carter	Carter Mutual Water Company
Jeff Ford	Castaic Lake Water Agency
Jeff Kightlinger	The Metropolitan Water District of Southern California
Jeff McLain	NOAA
Jeff Shields	South San Joaquin Irrigation District
Jeff Sutton	Tehama-Colusa Canal Authority
Jennifer Buckman	Friant Water Authority
Jim Wallace	Colusa Drain Mutual Water Company
John Beam	Grasslands Water District
John Herrick	South Delta Water Agency, Central Delta Water Agency
John Mallyon	James Irrigation District, RD 1606
Karen Huss	Sacramento Metropolitan Air Quality Management District
Kathleen Martyn Goforth	United States Environmental Protection Agency
Kim Forrest	United States Fish and Wildlife Service (USFWS)
Kirby Brill	Mojave Water Agency
Lance Boyd	Princeton-Codora-Glenn ID, Provident Irrigation District
Larry Rodriguez	Kern County Water Agency
Laurie Mikkelson	Colusa Indian Community
Lester Messina	Glenn County
Linda Bond	DWR
Lynn Phillips	Sutter Extension Water District
Mark Gilkey	Tulare Lake Basin Water Storage District
Maureen Kirk	Butte County
Michael Alves	Glide Water District, Kanawha Water District
Mike Wade	California Farm Water Coalition
Nancy Quan	DWR
Nina Bicknese	USFWS

Name	Agency
Osha Meserve	Local Agencies of the North Delta
Patrick Blacklock	Yolo County
Paul Bartkiewicz	Yuba County Water Agency
Paul D. Forsberg	CDFW
Paul Gosselin	Butte County
Paul Piraino	Alameda County Water District
Peter Rietkirk	Patterson Irrigation District
Ralph Bennett	San Joaquin National Cemetery (Department of Veteran Affairs)
Ric Ortega	Grasslands Water District
Ricardo Ortega	Grassland Water District
Rick Gillmore	Byron Bethany Irrigation District
Rick Massa	Orland Unit Water Users Association
Robert Harper	Westside Water District
Robert Toone	Palmdale Water District
Roger Jaegel	Trinity County
Ron La Grande	La Grande Water District
Ron Lee	Hothouse Water District
Russell Fuller	Antelope Valley-East Kern Water Agency
Scott Cantrell	CDFW
Scott Matyac	Yuba County Water Agency
Shauna Lorance	San Juan Water District
Shelly Murphy	Colusa County Water District
Steve Hackney	Colusa County
Steve Hirsch	The Metropolitan Water District of Southern California
Steve Kaiser	West Side Irrigation District
Steve Knell	Oakdale Irrigation District
Susan King	Orland-Artois Water District
Ted Trimble	Western Canal Water District
Terry Erlewine	State Water Contractors
Tom Filler	DWR
Vickie Newlin	Butte County
Walter Sadler	City of Folsom
William Brennan	Central Coast Water Agency
William Harrison	Del Puerto Water District, Oak Flat Water District

P.3 Non-Governmental Organizations

Table P-3. Non-Governmental Organizations Distribution List

Name	Group
Barbara Vlamis	AquAlliance
Bill Jennings	California Sportfishing Protection Alliance
Carol Perkins	Butte Environmental Council (BEC)
Carolee Krieger	California Water Impact Network
Carolyn Short	Butte Valley Coalition
Celeste Garcia	Sierra Club
Chelsea Tu	Center for Biological Diversity

Name	Group
Christine Nelson	Southwest Chico Toxics Task Force
Dave Garcia	Frack Free Butte
ECONorthwest	AquAlliance, California Sportfishing Protection Alliance, Aqua Terra Aeris Law Group
EJ Burkett	AquAlliance
Elizabeth Devereaux	AquAlliance
Grace Marvin	Sierra Club
James Brobeck	AquAlliance
Jay Ziegler	The Nature Conservancy, California Chapter
Jeffrey Volberg	California Waterfowl
John Scott	Butte Valley Coalition
Joni Stellar	Frack-Free Butte County
Julian Zener	Sierra Club
Kit Custis	AquAlliance, California Sportfishing Protection Alliance, Aqua Terra Aeris Law Group
Kyran Mish	AquAlliance, California Sportfishing Protection Alliance, Aqua Terra Aeris Law Group
Mark Biddlecomb	Ducks Unlimited
Nani Teves	BEC
Nelson Parmerter	Sierra Club
Rachel Zwillinger	Defenders of Wildlife
Robyn DiFalco	BEC
Sharon Fritsch	Sierra Club
Suzette Welch	Sierra Club
Tom Cannon	AquAlliance, California Sportfishing Protection Alliance, Aqua Terra Aeris Law Group

P.4 Individuals

Table P-1. Individuals Distribution List

Name
Aaron Ferguson
Allen Carrier
Amalie Sorenson
Andrew McClure
Barbara Hennigan
Bob Adams
Bob Hennigan
Bruce Smith
C. Wesley Strickland
Carl Schuhr
Cathy Busch
Cathy Webster
Charlie Yarbrough
Chuck Greenwood

Name
Cliff De Tar
Dan Everhart
Dan Frisk
Dave Walker
David Frankel
DeAnne Lory
Debbie Kick
Debbie MacTavish
Denise McNeil
Dennis Boyd
Diana Sue Good
Diane Monson
Douglas Wylie
Edwin Roland McNutt
Elena Middleton
Ellen Walker
Eric Miller
Eric Robinson
Fawna Montgomery
Frank Prentice
Gary Kienlen
Gary Middleton
GeneAnna McMillan
Geoffrey Baugher
George McArthur
Greg Amaral
Greg Young
H. Elena Middleton
Heather Gray
Idie Adams
J Barton
Jack Baber
Jain Redond
James Bennet
Jason Flanders
Jeanne Shelsky
Jeanne Zolezzi
Jill Pedrozo
John Dizzal
John Gray
John Johnson
John MacTavish
John Scott
Joshua M. Horowitz
Judy Vickrey
Julian Zener
Karen Stinson
Keith Landrum
Ken Fleming

Long-Term Water Transfers
Final EIS/EIR

Name
Kevin O' Brien
Kristi Bennett
Lance Wirtanen
Les Butler
Lieg Garton
Lila Prentice
Liliana Scarafia
Lily Rothrock
Linda Calbreath
Linda Lohjse
Lloyd Cleghorn
Lynne Elhardt
Marcell Gareis
Margaret Rader
Margaret Swick
Maria LaRocca
Marianna Love
Mark Montgomery
Mary McCluskey
Mat Baciorek
Melinda Teves
Misty Stewart
Nancy Praizler
Nancy Schleiger
Nevada Smith
Norma Samra
O.J. McMillan
Paul Johnson
Paula Sunn
Peter Jodaitis
Peter Rather
Peter Samra
Raul Morales
Ray Varlinsky
Richard Hauer
Richard Thieriot
Rob Montgomery
Rob Swartz
Robin Keehn
Ruthann Christensen
Sally Wallace
Sandy Boyd
Scott Lape
Seamus Yeo
Sherri Scott
Stephen Sayre
Steve O'Bryan
Steven Hammond
Susan Schuhr

Name
Susan Sullivan
Susie Lawing
Suzette Welch
Theodore A. Chester
Thom Shelsky
Tony St. Amant
Virginia Freeman
Walter Wangsgard
Wes Heitman
William Funke
William Tefteller
Zach Peek

This page left blank intentionally.